



INSTALLATION AND OPERATOR'S MANUAL

READ THIS MANUAL BEFORE INSTALLING OR USING YOUR YOUR LEGACY STOVES BOILER



HOT AIR FURNACES

Models: SF1500 • SF2500 • SF3500



IMPORTANT: IN ORDER TO ACHIEVE SAFE AND SATISFACTORY RESULTS FROM YOUR LEGACY STOVES FURNACE, READ SAFETY RULES AND INSTRUCTIONS CAREFULLY BEFORE INSTALLING AND OPERATING. ALL INSTALLATIONS MUST BE IN ACCORDANCE WITH STATE AND LOCAL CODES. INSTALLATION IS TO BE PERFORMED BY A QUALIFIED INSTALLER. SAVE THESE INSTRUCTIONS FOR FUTURE REFERENCE.



Your Legacy Stoves hot air furnace is capable of generating very hot temperatures. Temperatures and flames in the ignition box area are capable of igniting flammable vapors if drawn into the furnace. Flammable or explosive products must never be stored in the same room or in the vicinity of a furnace. **Please read this entire manual before you install or use your new furnace. Retain these instructions for future reference. Failure to follow these instructions may result in property damage, bodily injury, or even death.**

Legacy Stoves, A DIVISION OF:
ALTERNATE HEATING SYSTEMS
2393 LITTLE EGYPT RD
HARRISONVILLE, PA 17228
717-987-0099
www.legacystoves.com
EMAIL: support@legacystoves.com

Record Model and Serial Number Below:

Model:
Serial Number:
Date of Purchase:

SF1500/2500/3500 Sample Label

SF Series Solid Fuel Fired Furnaces

Manufactured by Alternate Heating Systems, LLC.
2393 Little Egypt Road Harrisonville, PA 17228
UL 391- UL Standard for Safety for Solid-Fuel and
Combination-Fuel Central and Supplementary
Furnaces, Fifth Edition, Dated September 10, 2010
Serial No. 000000
Date of Manufacture: February, 2015
Minimum Flue Diameter: 6" SF1500- 7" SF2500 SF3500
Applicable to solid fuel only



MH46626

Models: SF1500, SF2500, 3500	Minimum Circuit Ampacity (MCA): 15A	REFER TO OWNER'S MANUAL
Voltage: 120		✓ For basic operating and maintenance instructions, see owner's manual
Amps: 9	Max/Over Current	✓ This unit burns nut and stove coal only.
Frequency: 60 Hz	Protective Device: 40A	✓ Minimum .06 inches of water column draft
Phase: 1		✓ Field assembly of: Thermostat, Automatic Draft control, Shaker Handle, Electrical
Max. wire temperature 90°C	Electrical Load: Dampner Actuator 2A Distribution Blower 6A	✓ Draft control, Shaker Handle, Electrical Components, Blower Components, Ash Pan. (See installation manual for details)

DANGER: RISK OF FIRE OR EXPLOSION:

WARNING FIRE DANGER:

- Do NOT use chemicals for starting a fire.
- Do NOT burn garbage, gasoline, fuel oils, or other flammable liquids or materials.
- Do NOT store combustibles within marked installation clearances.
- Do NOT allow explosive vapors to accumulate in boiler room.
- Do NOT operate if flu draft exceeds .10 in of water column.
- Do NOT touch during operation.
- Do NOT operate with Load door, Ash door open.

CAUTION:

- Keep children away.
- Keep Clothing, furniture, and other combustible materials away.
- When loading and removing the ash.
- Inspect and clean the flu and chimney regularly.
- Unit is HOT while in operation.
- Do NOT connect to a flue serving another appliance.

All flue connections must meet all the requirements of NFPA Standard Number 211 and UL 103.
The appliance must be connected to an approved chimney made of masonry or manufactured
chimney listed for solid fuel.

IMPORTANT:

- It is important that you install a Carbon Monoxide (CO) detector.
Unit requires a supply of combustion air.
Unit will not operate without electrical power. Backup electric power may be provided to restore
unit to operation. Backup power must also power circulation. Do not run a backup generator in
the same area with the boiler or in any confined space. Disconnect power before servicing.
Keep shields and covers in place unless servicing boiler.
The heat exchanger, flue pipe and chimney must be cleaned at the end of each heating season. This
will serve to minimize corrosion during the summer months.
Use CO (carbon monoxide) detector in any furnace installation to detect the presence of gas that
may accumulate in the area around the furnace.
- In case of runaway fire:
1. Turn room thermostat to low setting.
 2. Make sure manual air controls are tightly closed.
 3. Make sure the automatic draft control on the lower door is closed.
 4. If a barometric damper is used in the smoke pipe, close it.

In a case of power loss:
It is important to remember that the heating system cannot dispose of a great deal of heat without
the distribution fan running. Avoid over firing! DO NOT LOAD LARGE AMOUNTS OF SOLID
FUEL INTO THE FURNACE! Fire the furnace cautiously until you are able to determine how
quickly the furnace is consuming fuel.

Copyright 2000 – 2015 Alternate Heating Systems
No portion of this publication may be reproduced without the
express written consent of Alternate Heating Systems.

Printed: 01/03/17

Table of Contents

Introduction.....	1
Safety Considerations.....	1
Additional Warnings and Notices.....	2
Carbon Monoxide (CO) Awareness.....	2
Chimneys and Venting.....	3
Venting Guidelines.....	3
Types Of Chimneys.....	3
Draft.....	4
Technical Aspects of Chimney Performance.....	5
Barometric Damper.....	5
Combustion Air (Make Up Air).....	6
Masonry Chimneys.....	6
Prefabricated Chimneys.....	6
Common Chimney Problems.....	7
Insufficient Draft – Common Issues.....	7
What to Do if You Have a Problem.....	8
If you have a chimney fire:.....	8
In Case of a Runaway Fire.....	8
Smoke puffs out of the furnace:.....	9
Chimney Specifics.....	9
Stovepipe.....	10
Wall Pass-Through: United States.....	11
Wall Pass-Through: Canada.....	11
Installation.....	12
Furnace Location.....	12
Clearances.....	12
Rigging and Positioning.....	13
Assembly.....	13
SF1500 • SF2500 • SF3500.....	14
Mounting The Blower And Filter Box.....	14
Wiring.....	15
SF1500/SF2500/SF3500 Wiring Diagram.....	16
Duct Work.....	17
Duct Work.....	17
Operating Instructions.....	18
Controls.....	18
Thermostat.....	18
Adjusting Automatic Draft Control.....	18
Adjusting the fan control.....	19
Startup.....	20
Curing Paint.....	20
Wood vs Coal.....	20
Fuel Capacity – Wood or Coal.....	20
Starting a Wood Fire.....	20
Starting A Coal Fire.....	21
Loading Additional Coal.....	21
Maintaining a Coal Fire.....	21
Shaking.....	22
Ashes.....	22

Grates.....23

Other General Operating Guidelines.....23

 Operation During a Power Failure.....23

Maintenance.....25

Spiral Chamber.....25

Firebricks.....25

Specifications.....26

Special Instructions.....27

 Coil installation.....27

Special Instructions.....28

 Coil Installation.....28

 28

 Service Parts: SF1500.....29

 Service Parts: SF1500 (continued).....30

 Service Parts: SF2500.....31

 Service Parts: SF2500 (continued).....32

 Service Parts: SF3500.....33

 Service Parts: SF3500 (continued).....34

 Warranty Information (2 Pages).....35

Service and Maintenance Log.....37

Service and Maintenance Log.....38

Introduction

Thank you for purchasing a Legacy Stoves™ hot air furnace. Whether you're heating a room or heating your whole house, you've made the right choice. Please read this entire instruction manual before attempting to install or operate your new furnace. If you have further questions regarding your new furnace, contact your Legacy Stoves™ dealer. Follow these instructions and you will have many years of warmth and comfort enjoying your new furnace.

Safety Considerations

When opening the loading door, it should be cracked open slightly for a few seconds to allow oxygen to burn any gases that may be present and to allow smoke and gases to be drawn away from the door.

CAUTION! ALWAYS WEAR FIRE-RESISTANT GLOVES TO OPERATE THE FURNACE. THE AIR CONTROL IS HOT WHILE IN OPERATION.

Whenever the bottom door is open, it should be closed before opening the loading door. This is to increase draft through the loading door and prevent excess smoke from escaping.

The firebox should never be filled with excessive coal or wood such that the flue exit is blocked or impeded in any way. Burning coal generates carbon monoxide. If the flue gas exit is blocked, the carbon monoxide can be forced out of the furnace into the room with possible fatal consequences.

With the exception of start up or increasing heat from a low fire, or removing ashes, the bottom door should be kept closed. Never install a Legacy Stoves furnace to a chimney with a history of down drafts.

CAUTION: ALL SURFACES OF FURNACE ARE HOT. DO NOT TOUCH. KEEP CHILDREN AWAY. SERIOUS BURNS WILL RESULT IF TOUCHED. THIS IS A HEAT PRODUCING APPLIANCE.

DANGER! FIRE HAZARD! DO NOT USE CHEMICALS OR FLUIDS TO START OR "FRESHEN UP" A FIRE. SEVERE BODY BURNS OR A FIRE IN YOUR HOME COULD RESULT. DO NOT BURN GARBAGE, GASOLINE, THINNERS, DRAIN OR ENGINE OIL, KEROSENE, OR FUEL OIL, ETC. AN EXPLOSION, A HOUSE FIRE OR PERSONAL INJURY COULD RESULT. KEEP ALL SUCH LIQUIDS WELL AWAY FROM THE FURNACE WHILE IN USE.

Additional Warnings and Notices

Carbon Monoxide (CO) Awareness

Carbon monoxide, referred to as CO, is a colorless, odorless gas that is produced during combustion of coal and other fuels. CO fumes are toxic and can be fatal. Safe operation of your Legacy Stoves hot air furnace relies on a properly functioning chimney to remove CO and other combustion by-products from the furnace. Even though this furnace is designed to be as safe as possible, it is important that you install a CO detector. This is true for oil, gas, or wood as well. CO is not specifically heavier or lighter than air. Therefore, it is best to install the detector at table top level rather than on the ceiling like a smoke detector.

CO detectors are very sensitive and may sound an alarm for fumes other than CO or CO from sources other than the furnace such as car or lawn mower exhaust. If the alarm sounds:

1. Increase ventilation by opening windows or doors.
2. Make sure the furnace doors are closed and latched.
3. Check furnace for normal operation.
4. Check for false alarm.
5. Have all occupants exit the building until the cause for the alarm is discovered and/or remedied.

CAUTION! NEVER USE GASOLINE, GASOLINE-TYPE LANTERN FUEL, KEROSENE, CHARCOAL LIGHTER FLUID, OR SIMILAR LIQUIDS TO START OR "FRESHEN UP" A FIRE IN THIS HEATER. KEEP ALL SUCH LIQUIDS WELL AWAY FROM THE HEATER WHILE IT IS IN USE.

DO NOT LEAVE SMALL CHILDREN UNATTENDED WHILE IN THE ROOM WITH THIS HEATER.

WARNING: DO NOT INSTALL A FLUE DAMPER IN THE EXHAUST VENTING SYSTEM OF THIS APPLIANCE. DO NOT CONNECT THIS UNIT TO A CHIMNEY FLUE SERVING ANOTHER APPLIANCE.

NEVER SLEEP IN THE SAME ROOM WITH ANY COAL BURNING FURNACE! DO NOT INSTALL IN A SLEEPING ROOM.

DO NOT OVERFIRE – IF HEATER OR CHIMNEY CONNECTOR GLOWS, YOU ARE OVERFIRING.

THIS APPLIANCE IS ALSO APPROVED FOR INSTALLATION INTO A SHOP.

CAUTION! FAILURE TO FOLLOW THE INSTALLATION INSTRUCTIONS IN THIS MANUAL, OR USING MAKESHIFT COMPROMISES DURING INSTALLATION MAY RESULT IN PROPERTY DAMAGE, PERSONAL INJURY OR DEATH!

THIS HEATER IS NOT AN INCINERATOR. DO NOT BURN GARBAGE OR FLAMMABLE LIQUIDS SUCH AS GASOLINE, NAPHTHA, OR ENGINE OIL!

HOT WHILE IN OPERATION. KEEP CHILDREN, CLOTHING AND FURNITURE AWAY. CONTACT MAY CAUSE SKIN BURNS.

WHEN INSTALLING IN A TIGHTLY CONSTRUCTED HOME, A SOURCE OF FRESH AIR TO THE ROOM MAY BE NECESSARY FOR PROPER OPERATION OF THIS APPLIANCE.

ALWAYS WEAR GLOVES WHEN ATTENDING TO THIS HEATER

INSTALLATION IS TO BE PERFORMED BY A QUALIFIED INSTALLER. INSTALLATION WILL COMPLY WITH ALL THE REQUIREMENTS OF THE AUTHORITY HAVING JURISDICTION OVER THE INSTALLATION.

Chimneys and Venting

Venting Guidelines

Your Legacy Stoves hot air furnace must be vented to its own separate flue. This must be a lined "Class A" chimney. If clay tile lined, this to be not less than 8" X 8" in size. If the chimney is a listed manufactured chimney, it is not to be less than 6 inches in diameter. The chimney must be capable of providing a draft reading of at least -.06" water column on a draft meter, in order to function properly. The Chimney must be a minimum of 16 ft. high, measured from the height of the flue collar, and must be two feet higher than anything within 10 ft. The chimney must also be at least 3 ft. higher than the point at which it exits or passes by the roof. A barometric damper must be installed in the flue to eliminate excessive draft. Any horizontal sections of connector pipe must have at least 1/4 in. per foot rise. Limit the number of elbows to two or less. All joints in the connector pipe must be secured with sheet metal screws.

MAINTAIN CHIMNEY AND CHIMNEY CONNECTORS, KEEP CLEAN AND IN GOOD CONDITION!

Types Of Chimneys

The chimney is one of the most important, yet most neglected and misunderstood portions of any solid fuel burning furnace installation. Do not connect this furnace to a chimney flue serving another heating device.

Chimney connectors shall not pass through an attic or roof space, closet or similar concealed space, or a floor or ceiling. Where passage through a wall, or partition of combustible construction is necessary, the installation shall conform to CAN/CSA-B365, Installation Code for Solid-Fuel-Burning Appliances and Equipment.

Where an existing chimney is used, it must be large enough to provide a draft adequate for removing gaseous products of combustion.

From NFPA 211 2013:

The cross-sectional area of the chimney system must not be less than that of the flue collar.

Chimney systems which are completely internal below the roof line must be no more than three times the cross-sectional area of the flue collar ($28.3 \text{ in}^2 \times 3 = 84.8 \text{ in}^2$).

Chimney systems which are exposed to the exterior on one or more sides below the roof line must be no more than two times the cross-sectional area of the flue collar ($28.3 \text{ in}^2 \times 2 = 56.5 \text{ in}^2$).

There are three types of class "A" chimneys:

- 1) Masonry with tile liner, to include brick or stone. It must be supported on grade level foundation.
- 2) Insulated, manufactured chimney, listed or certified by a national test agency.
- 3) Triple-wall metal class "A" chimney, listed or certified by a national test agency.

If your masonry chimney has not been used for some time, have it inspected by a qualified person. If a listed or certified manufactured chimney is to be used, make certain it is installed in accordance with the manufacturer's instructions and all local and state codes.

The minimum recommended height for solid fuel chimneys is 16 feet from the furnace collar. This should be 20 feet for masonry chimneys. Reference the section on barometric dampers for more info. The chimney must be two feet higher than anything within ten feet. It also must extend at least three feet above the point where it intersects or exits the roof line.

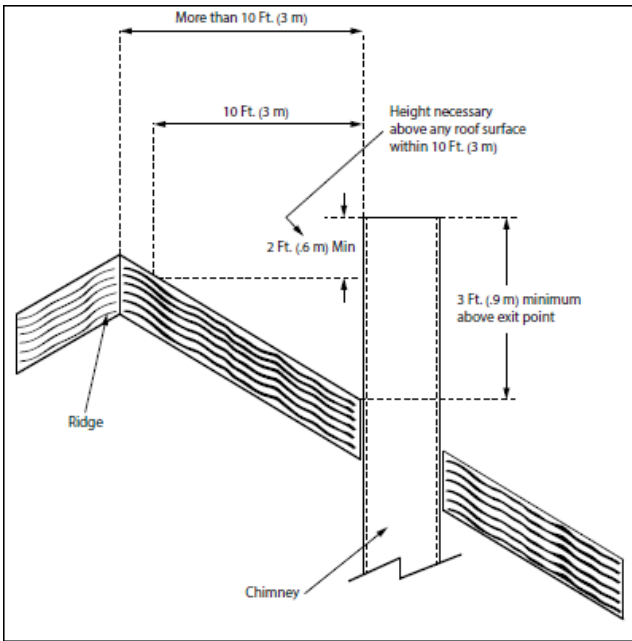

The three foot, two foot, ten foot rule

Draft is created by a pressure differential between the bottom and the top of the chimney. Chimney height, air moving across the top of the chimney, and warmer air in the chimney than outside will all result in greater pressure differences and stronger draft. A warm chimney drafts better than a cold one. For this reason a chimney drafts best when kept warm. It is more difficult to maintain sufficient temperature in an exposed chimney. A larger chimney, or one with a lot of thermal mass will also present more problems than a chimney that is protected from outside temperature extremes. A chimney must be kept warm (about 250° F) for proper draft to occur. A chimney's height, expressed as the difference between the top opening and the flue pipe connection on the appliance, contributes to draft because atmospheric pressure is naturally lower at the chimney top than bottom.

THE FURNACE MUST BE CONNECTED TO ITS OWN CHIMNEY. FOR A TILE-LINED FLUE, A MINIMUM FLUE SIZE OF 8" X 8" IS NECESSARY FOR PROPER OPERATION.

MANUAL DAMPERS OR "HEAT SAVERS" MUST NEVER BE INSTALLED IN THE FLUE PIPE. IMPROPER OPERATION COULD RESULT IN DEATH.

CAUTION: THE CHIMNEY MUST BE A CLASS "A" CHIMNEY, IN GOOD OPERATING AND CLEAN CONDITION.

NOTE: THE USE OF ALUMINUM TYPE "B" GAS VENT FOR SOLID FUELS IS UNSAFE AND PROHIBITED BY THE NATIONAL FIRE PROTECTION AGENCY CODE.

⚠ CAUTION	
	CREOSOTE BUILDUP PROBLEMS
<p>Poor chimneys with cold walls can cause creosote buildup. Sharp bends and horizontal flues should also be avoided. The exhaust must be kept moving through the piping/flue to prevent creosote or fly ash buildup. If a horizontal section must be used, it must rise slightly to prevent dead air space.</p>	

Draft

In order to have a properly operating solid fuel heating system, the chimney must be capable of providing the necessary draft. The minimum required draft is -.06 inches of water column (W.C.). This must be measured using a draft gauge. If the chimney cannot supply this constant draft, the furnace will not operate properly. A barometric damper may be used and properly adjusted to compensate for excessive draft.

The chimney must be sufficiently tall (at least 20 feet for masonry chimneys) and should extend several feet above the highest part of the roof to prevent downdrafts. Follow code requirements for your area and consult a chimney professional. Keep in mind the 3-2-10 rule, as depicted below. The chimney must be leak-free from the standpoint of air entering through cracks or other chimney defects or through loose stovepipe fittings.

IMPORTANT: When you measure the draft, the furnace must be operating with sufficient time given for the furnace and chimney to warm. Burn for at least thirty minutes. The draft reading is best taken 18" up from the center of the flue outlet, in the connector pipe. Drill a hole in the pipe for the meter

tube, and fill it with a screw or silicone when done with the test.

IMPORTANT: The connector pipe must be 24 gauge or thicker.

When connecting the flue pipe to the furnace, the first section should be installed inside the furnace collar. It should be secured to the collar with, at least, three screws or rivets. Do not pass the connector pipe through a wall or ceiling without first checking with your local codes. If allowed, use only approved pass-thru methods.

NOTE: All horizontal runs of venting should have a 1/4 inch of rise per foot of length.

Use no more than two 90° elbows in the connector. If a barometric damper is needed, to compensate for excessive draft, install it only in a vertical section of vent pipe.

Technical Aspects of Chimney Performance

A device called a manometer is used in describing the technical performance of a chimney. A manometer is an instrument used for measuring the pressure of liquids and gases. An analog manometer consists of a glass tube filled with a liquid and mounted in front of a measuring scale against which the liquid level can be measured. If a manometer were connected to a leak-free chimney with a leak-free connection, then the draft in the chimney should exert enough pressure (or pull) against the water in the manometer to cause it to move at least -.06 inches in the tube. For units to be operated on coal, limit maximum draft to -.10 inches. Use of a barometric damper may be required.

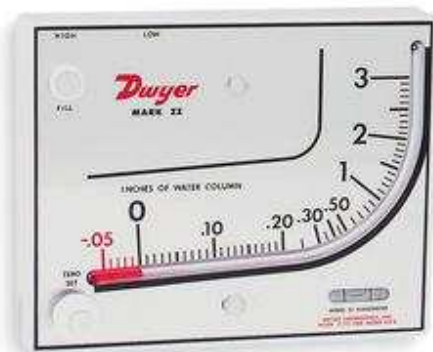

Dwyer Manometer

To measure the draft, drill a hole in the connector pipe and attach a draft meter or manometer. First, check the draft above the barometric damper (if

installed). Then check it below the barometric damper and make your damper adjustment to where it opens to prevent the draft from going higher than -.10 inches of water column. If the chimney is incapable of supplying the required draft, it will need to be improved. See the section on Common Chimney Problems for more information.

Barometric Damper

A barometric damper is a device that allows room air to enter the chimney, bypassing the air intake on the heater. A heater and chimney combination that drafts well will occasionally produce more draft than is desired. Excessive draft can lead to the fire burning out of control and excessive heat production. It will also lead to reduced efficiency, as more heat will end up going up the chimney. A barometric damper is used on a coal fired heater to limit maximum draft to -.10 column inches or less. The barometric damper needs to be the same diameter as the stove collar. It is to be installed in the chimney connecting pipe as shown below, utilizing a Tee in the stove pipe.

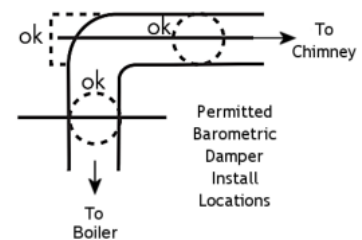

It is important to check the chimney draft when the seasons change to ensure draft settings are correct. Changes may be needed when transitioning from winter heating to summer heating (domestic water heating). The amount of draft will change from one season to the next. It is not uncommon to add a draft inducer in warmer seasons to maintain the recommended -.06 to -.10 inches of water column.



Barometric Damper

Combustion Air (Make Up Air)

The airflow through the system and out the chimney means that oxygen is leaving the home and will create an oxygen deficit if this air is not replaced. Adequate combustion air is critical for the performance of your heater. There is usually sufficient leakage in older homes to provide for this, but in well-insulated homes it may be necessary to provide additional outside air into the home. Combustion air can be provided with a duct to the outside. A louvered vent can also be used.

⚠ CAUTION	
	SUFFOCATION HAZARD
<p>The airflow through the system and out the chimney means that oxygen is leaving the home and will create an oxygen deficit if this air is not replaced.</p>	

Masonry Chimneys

If you plan on using a preexisting masonry chimney, have it thoroughly inspected and cleaned. Any faults which make the chimney unsafe and unusable must be repaired prior to use. These can include improper height, structural defects, blockages, inadequate clearance to combustibles, unsealed openings into other rooms of the house, signs of creosote or smoke leakage, a loose or absent clean-out door, or absence of a liner.

When connecting to a masonry chimney, several provisions are standard. First, whether the chimney connector is vented to the chimney through a thimble or a breech pipe, neither must pass beyond the inner surface of the chimney liner, and both must be firmly cemented in place with refractory cement. (A thimble is a masonry pipe which is inserted through the chimney wall, and is frequently the preferred method; a breech pipe is a piece of steel pipe used the same way.) In Canada, a breech pipe has ridges or protrusions to lock it firmly into the refractory cement. In either case, the chimney connector vents to the chimney through the thimble or breech pipe. See wall pass-through information in the section on stove pipe.

Prefabricated Chimneys

When venting your furnace using a prefabricated chimney, be sure to contact local building code authorities, and to follow the manufacturer's instructions exactly. Use only the manufacturer's parts and use all required parts. Do not use makeshift installation techniques. All prefabricated chimneys must be tested to either the U.S. or Canadian high-temperature standards, UL 103 or ULC-629.

Your manufactured chimney may contain more parts than is shown in the subsequent diagrams. Include all required items in your installation. A chimney cap (A) serves to keep rain and snow from entering the chimney. An approved Class A chimney (B) is required for the SF170 and SF270 furnaces. Wall Bands (C) must be deployed for support per manufacturer's recommendations. A manufacturer's Wall Support Kit (D) will contain required items for supporting the chimney. Such kits will cost less than individual items purchased separately. A Bottom Cap (E, location marked, but actual cap not shown) allows for cleaning. A Finishing Collar (F) provides inside wall protection. A Wall Thimble (G) provides for required clearance between the chimney pipe passing through a flammable wall. The Chimney Connector (H) must be approved single wall, or a low clearance pipe, installed with required clearances in place. A Roof Brace (I) is required for chimneys that extend more than a certain distance, as referenced by the manufacturer's instructions, from the roof. Manufactured chimneys may feature

a built in “twist lock” at each joint, but a Joint Band (J) is still normally required to secure pipe at the joint. An approved Chimney Pipe Adapter (K) is required. A Ceiling Support (L) will provide structural support for the chimney and is typically part of a kit that includes items that maintain required clearances to flammables. A Storm Collar (M), and Adjustable Flashing (N) prevent water from entering the home by running down the outside of the chimney. Additional items or a kit (O) provide additional mounting support or fire protection to the roof joists or other roof components.

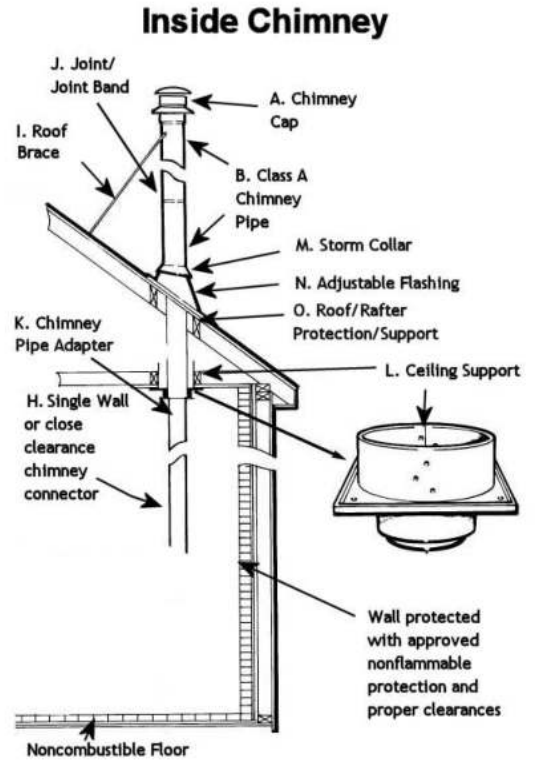

Outside Chimney

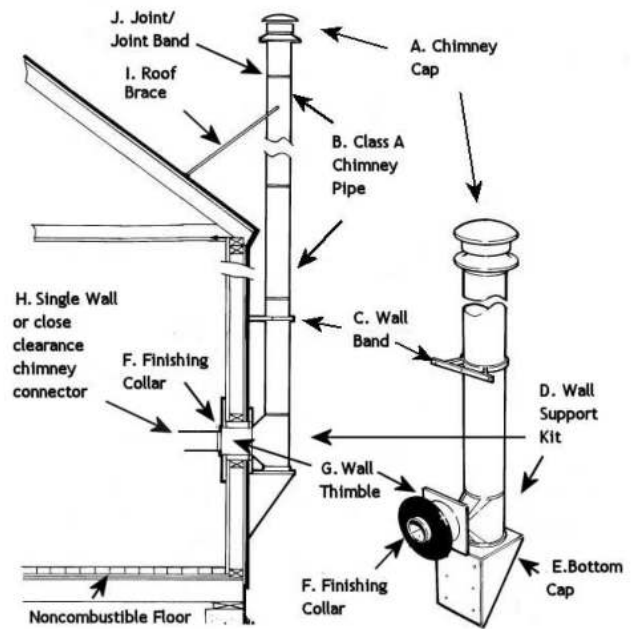

Common Chimney Problems

Insufficient Draft – Common Issues

A. Chimney Leaks - Air leaking in around a loose fitting cleanout door, flue pipe joints and/or seams not secured, improper plug openings or defective masonry.

B. Chimney Too Short - The general rule for chimneys; 16 feet tall, three feet above the roof exit, and two feet taller than anything within ten feet.

C. Blocked Chimney - Have the chimney cleaned and inspected prior to installation and before each heating season.

D. Trees Or Other Topographical Barriers - Impeding on the chimney's operation or causing a down draft situation. This can also be caused by adjacent buildings or another roof of the same structure giving air currents a downward swirl.

NOTE: The chimney on the illustrated house is too low, it should be raised to compensate for down draft potential.



E. Chimney Size - The chimney cannot be smaller than the flue exit from the appliance. Too large of a chimney could stay too cool to promote adequate draft.

F. Chimney Offsets - Offset chimneys should be avoided. The offset area can collect debris and cause a blockage.

G. Elbow restrictions - There should be no more than two 90° elbows or the equivalent used in connecting the furnace to the chimney flue.

H. Shared Flue - No more than one appliance shall vent into a single flue.

The most common cause of poor draft is an improperly sized flue liner. It is recommended that the inside dimensions of the liner be at least as large as the appliance flue outlet and no larger than 125% of the collar for a round flue. An example, a 8" flue collar is 50 square inches. Increased by 25% would be

63 square inches, or approximately a 9" round flue. In general for round liners, it is recommended that they not be increased by more than one inch from that of the furnace collar. This will help ensure proper draft with the lower flue temperatures.

REMEMBER: A solid fuel burning furnace can only perform as well as its venting system will allow it to.

THE MOST IMPORTANT THING TO REMEMBER ABOUT CHIMNEYS IS THEIR NEED FOR MAINTENANCE AND CLEANING. IF A CHIMNEY IS NOT CLEANED ON A FREQUENT BASIS, IT WILL AFFECT THE DRAFT AS WELL AS POSSIBLY CONTRIBUTE TO A CHIMNEY FIRE.

What to Do if You Have a Problem

If you have a chimney fire:

1. Be sure everyone is out of the house.
2. Call the fire department.
3. Close the draft control on the ash door and make sure both doors on the furnace are closed and latched.
4. Wet down the area of the roof surrounding the chimney. Do not wet the chimney itself or try to put water down the flue as it will very likely damage the flue tiles.
5. Do not put water on the fire, this will cause unnecessary damage to the furnace and flue.
6. Have the chimney inspected and repaired prior to building another fire.

In Case of a Runaway Fire

1. Shut the furnace down by disconnecting power from draft control or forced draft fan. Do this without cutting power to the distributor blower (see step 3).
2. Be sure the draft inducer is off and/or make sure the barometric damper opens. (Excessive draft can cause a runaway fire.)
3. Maintain continued movement of furnace distribution fan to pull air and remove heat from the

furnace and if furnace is equipped with a domestic coil run hot water.

Smoke puffs out of the furnace:

1. Check previous suggestions for insufficient draft.
2. Check draft control for proper operation.
3. Chimney may be too low. Increase height.
4. Add more fresh air to the room. Your home may be so tight that there is not enough oxygen getting to the fire.
5. Remember, open the draft control and crack the door open slightly before reloading or checking the fire.
6. Check the ashes. The ash pan and firebox may be overloaded with ashes.
7. Check the chimney cleanout door to ensure it closes properly.

**WARNING - DO NOT CONNECT THIS
UNIT TO A CHIMNEY SERVING ANOTHER
APPLIANCE!**

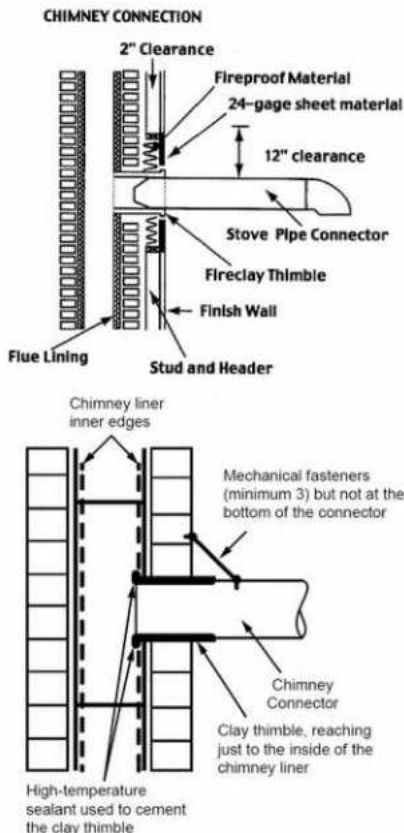

Chimney Specifics

- A) Flue connecting pipe must not be less than 6 inches in diameter (7 inches for the SF2500 and SF3500) and of 24 gauge or heavier.
- B) Connecting pipe joints are to be secured with screws (preferred) or pop rivets. Suggested location for fasteners is at the 12/4/8 o'clock positions. Refractory cement may be used at furnace and chimney collar to secure these connections. Keep in mind that disassembly may be periodically needed, so that the chimney and connecting pipe may be cleaned and inspected.
- C) Masonry Chimney Connections - A minimum of 12 inches of solid masonry is required around a 5/8 inch thimble if the pipe passes through a combustible wall. It is also acceptable to use a UL listed prefabricated wall pass through. If such a pass through is used, all the components comprising a complete pass through kit must be included, as per manufacturer's recommendations.
- D) Masonry Fireplace Chimney Connections - In some situations, a code compliant chimney originally used for a masonry fireplace may be used. The chimney must be lined with the needs of the heating appliance in mind, including minimum and maximum sizes. The lining will comply with one of the following:
 - Clay flue lining complying with the requirements of ASTM C315 or equivalent.
 - Listed chimney lining systems complying with UL 1777.
 - Factory-built chimneys or chimney units listed for installation within masonry chimneys.
 - Other approved materials that will resist corrosion, erosion, softening, or cracking from flue gases and condensate at temperatures up to 1,800° F. (982° C)

Insulated liners work best for maintaining good draft. In addition to the requirements found in the previous paragraphs, it is important to be aware that all clearances must be met, including those from the chimney connector to combustibles. Do not forget to

include floor protection in your plans. (See Clearances and Floor Protection) Since many fireplaces have exposed wooden mantels and trim, pay special attention to the clearances necessary to these materials. If your fireplace chimney is behind a combustible wall, you must use an approved wall pass-through system to gain access to the masonry chimney. The chimney connector must enter the chimney at a place where it is lined, and the fireplace must be made inoperable. For example, you might remove the damper, replacing it with a secure, airtight, noncombustible seal (removable for inspection); this also satisfies the requirement that no room air must be allowed to enter the chimney.

Stovepipe

It is recommended that overall flue connecting pipe length be kept to a minimum. Any horizontal runs must slope upward towards the chimney, with a minimum rise of 1/4 inch per foot. Use a minimum number of elbows, preferably no more than two, to make the chimney connection.

Particular attention should be paid to the point where a flue passes through a wall or ceiling. The pass-thru should always be made with insulated pipe and the proper accessories or use of a thimble that provides a diameter of not less than three times the diameter of the stovepipe. If the chimney must go through a combustible wall, be sure to use a metal thimble specially designed for this purpose. The proper way to install a thimble is to cut an oversize hole in the sheetrock about 6 or 7 inches larger than the thimble. However, be sure to follow the manufacturer's directions that come with the thimble. A metal ring shield is used to cover the hole. This way air can circulate and cool the area around the passageway.

Note: Do not decrease the diameter of chimney pipe to less than that of the flue collar! Chimney connector and flue must be 6 inches in diameter or greater for the SF1500, 7 inches or greater for the SF2500/3500 models.



Note: Legacy Stoves hot air furnaces are not EPA approved for continuous firing with wood. Only use wood for preparation for a coal fire.

Wood fires of low intensity, or low smoldering fires are likely to produce creosote buildup. Tars and other organic vapors combine with moisture from the fuel and from combustion byproducts to form creosote. The more time the boiler is fired with wood at low fire, the more opportunity for buildup of creosote inside the stove pipe and chimney. Inspect at least twice monthly, and remove if buildup occurs. Your Legacy Stoves hot air furnace is not EPA approved for continuous firing with wood. Wood is only to be used for preparation for a coal fire. Prevention is your best option. If creosote is observed, a coal fire will serve to dry up the creosote, after which it can be removed manually from the chimney and stove pipe with the appropriately sized cleaning brushes. See additional fuel related cleaning recommendations in the section on Furnace Operation and Maintenance.

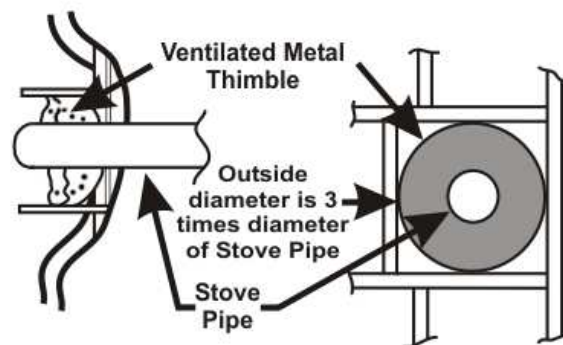

Stove pipe passing through wall



Use 24 gauge or heavier single wall stove pipe in open areas that are no closer than 18 inches from walls or ceiling. If the stovepipe must be closer than 18 inches from the nearest wall or ceiling, or if it must go through walls, closets, or boxed in areas, then UL listed insulated stovepipe must be used. Pipe that runs along the outside walls of a building must also be UL listed insulated pipe, even if it runs along a non-combustible outside wall. This requirement is in place in order to prevent cooling of the stovepipe which in turn cools the rising smoke and causes creosote to form quickly. The diameter of stovepipe must be at least 8 inches.

Wall Pass-Through: United States

In the U.S., the national code is NFPA 211. While many localities adopt this standard, be sure to check with local authorities before beginning your installation. The NFPA (National Fire Protection Association) permits four methods for passing through a combustible wall. A commonly used method to pass through a wall directly to a masonry chimney is to clear a minimum 12"(300 mm) around the entire chimney connector, and fill it with brick masonry which is at least 3.5"(90 mm) thick. A fireclay liner, minimum 3/8" (9 mm) wall thickness must run through the brick wall to the chimney liner (but not beyond the inner surface of the liner). It must be cemented in place with refractory cement. This method is illustrated. For details on the other three options, refer to the most recent edition of the NFPA 211 code.

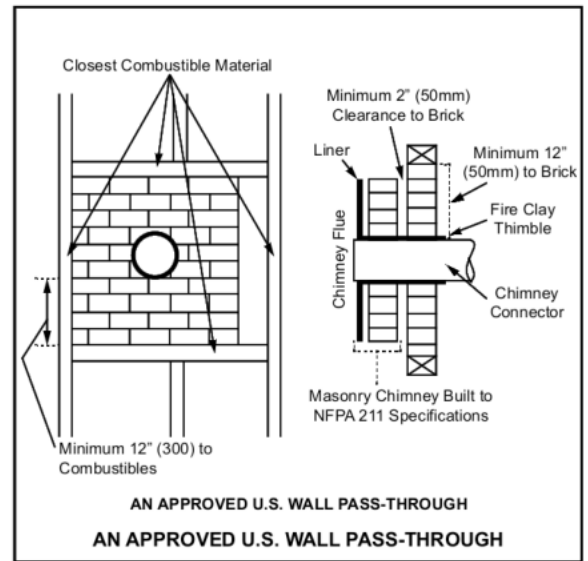

U.S. Wall Pass-Through

Wall Pass-Through: Canada

Three methods are approved by the Canadian Standards Association. The diagram following this paragraph shows one method requiring an 18" (450mm) air space between the connector and the wall. It allows use of one or two covers as described in the diagram. The two other methods are described in detail in the current issue of CAN/CSA B365, the national standard.

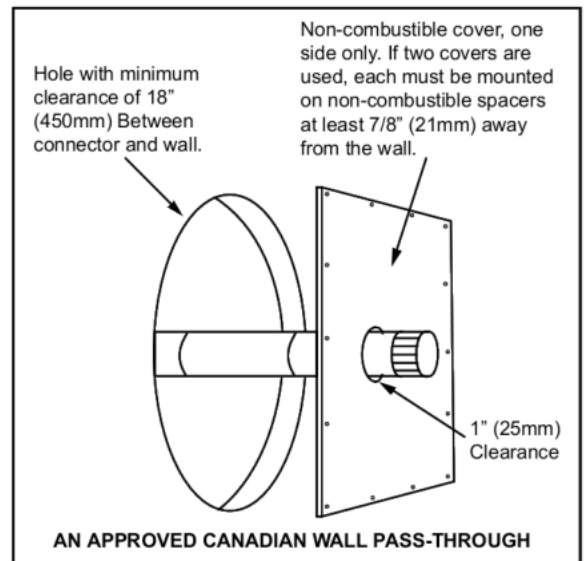

Canadian Wall Pass-Through

Installation

Furnace Location

Your SF1500/SF2500/SF3500 furnace will radiate a good deal of heat. This heat can be dangerous if the furnace is improperly installed.



The furnace must stand on a noncombustible material such as brick, stone tile or concrete. The floor needs to be flat and must be able to support the furnace's weight, plus the weight of any attachments. NEVER place a furnace directly on a wood floor. If a noncombustible material is used under the furnace to protect a combustible floor, than this material must extend at least 12 inches beyond the base of the furnace in the rear and on the sides and at least 36 inches in front. Floor protection must also extend 2 inches beyond flue connecting pipe also. See the floor protection chart and diagram that follows for installation guidelines.

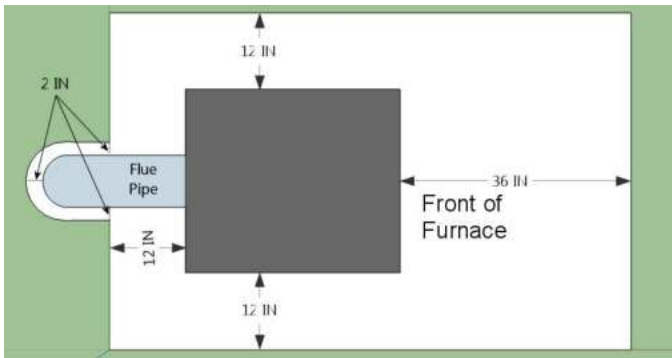

Floor Protection Diagram

To ensure a safe installation, this furnace is to be installed by a qualified installer.

The sheet metal top and sides can be easily removed to reduce the chance of dents or scratches on the painted surfaces. To remove the sheet metal, first lift off the top section. Now, the sides can be

removed by lifting up and out away from the furnace.

Locate the furnace as close to the chimney as possible while still maintaining the listed clearances. No more than 8 feet of furnace pipe should be used, including two or less 90° elbows. All horizontal runs of pipe should have a minimum 1/4 in. rise per foot. All furnace pipe must be 24 gauge or thicker.

Re-install the sheet metal by sliding the groove on the bottom of each side panel over the steel lip on the furnace. The top sheet metal piece holds the sides in place.



Clearances

Listed Clearances	
Front	36 Inches
Sides	24 Inches
Rear	36 Inches
Top	24 Inches
From Plenum Top	2 Inches

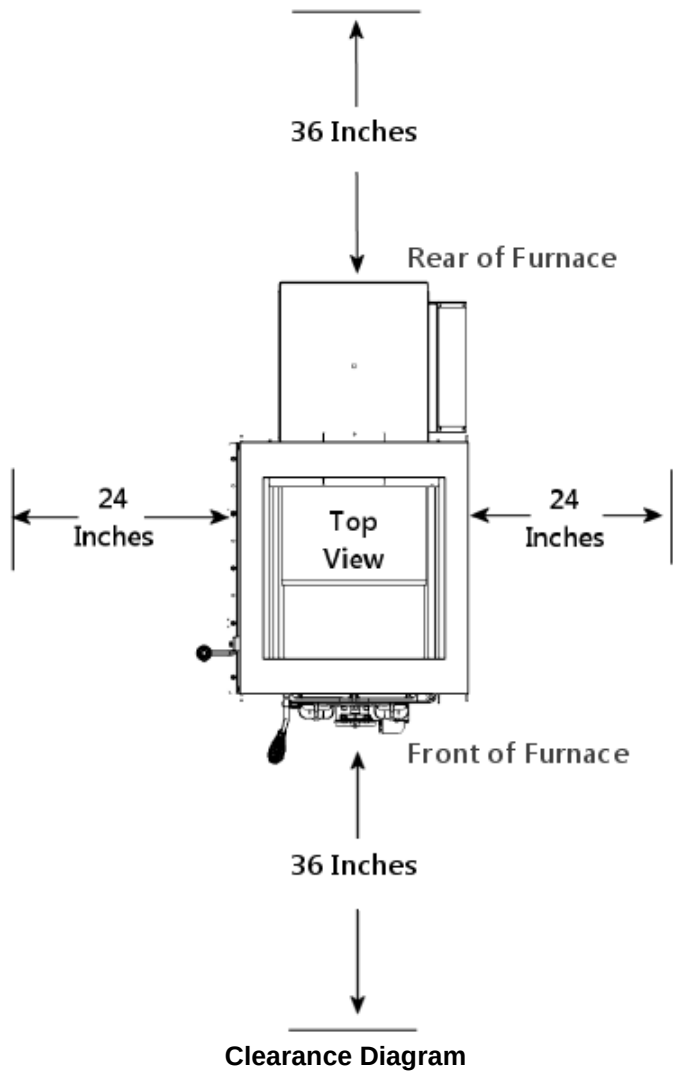

Clearance Diagram

The furnace must be installed in an area dedicated to it and its related equipment. Review the following checklist:

- ✓ Furnace area must be partitioned or separated from any living area of a residence.
- ✓ The room must have a constant fresh air supply to assure proper combustion of the fuel as well as ventilation of any by-products of combustion.
- ✓ The room should have good lighting, with a source of emergency lighting as well.
- ✓ An electrical disconnect should be present at point of entrance to the furnace room.
- ✓ Walls and ceiling must be of fire rated construction. Consult code requirements.



Rigging and Positioning

Do not attempt to move or off-load the furnace without the aid of a crane or dolly. Most Legacy Stoves furnaces have a lifting lug in the center of the top. Once on the floor level where it will be installed the unit may be rolled on pipe or may be moved by means of a pallet jack. The furnace must be placed on a concrete slab or other rigid pad of non-combustible material with sufficient strength to adequately support the furnace including any attachments, and be positioned as closely as possible to the chimney. The smoke pipe must pitch continually upward toward the chimney and be as straight as possible. Level the furnace after it has been positioned.

Assembly

Bolt the shaker handle to the block on the lower left side of the furnace, using the bolts and lock-washers provided. Bolt the two manual draft controls to the front load door. Proper installation allows the draft controls to open approximately 1/2" from the door surface. See Figure 1.

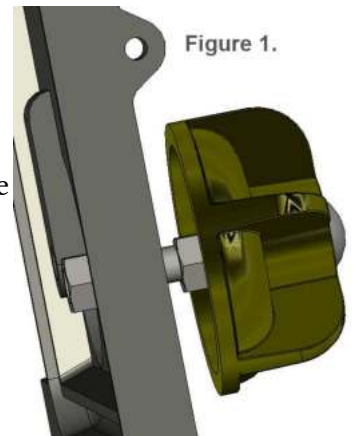

Figure 1.

Bolt the automatic draft control to the bottom door. Be sure to hold the unit straight while tightening. After the automatic draft control is mounted, the two wires must be strung through the flexible conduit and two fittings supplied. The knockout plug of the junction box must be removed

to install the conduit fitting. Check the door of the automatic draft control to assure proper operation. Warning: Keep pieces of wood or coal out of the draft door opening mechanism, as this could cause the door to stick.

Note: Oil the hinge at the beginning of the heating season with a light oil.

The junction box is best mounted on the side of the furnace about 1 in. back and 8 in. from the top of the sheet metal side. If this location is inconvenient, anywhere on the right side will work.

SF1500 • SF2500 • SF3500

Please note that this drawing is for reference only. Each specific installation will vary.

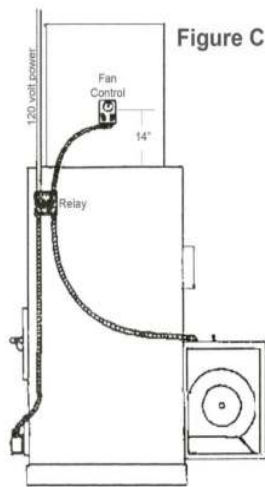

Mounting The Blower And Filter Box

Position the filter box between the brackets on the rear of the furnace, with the bottom of the box resting on the flange at the bottom of the furnace. Insert the mounting clips into the bracket slots to secure the filter box. (see Figure 2) Next, install the blower brackets onto the blower being sure to install the rubber feet into the brackets. **All hardware, brackets, etc. for the blower, will be found in the carton with the blower.** Next, position the blower in the filter box, centered behind the inlet hole and allow approximately 1/8 in. space between the rear of the furnace and the blower outlet. Now, install the filter rail onto the filter box. NOTE: The filter rail is best installed on the side toward the shaker handle, so that any pipes from the hot water coil do not interfere with filter installation or removal.

Note: Before proceeding with the installation of the access door, it is suggested that the wiring be completed.

The access door is installed by slipping the flange on the bottom of the access door over the bottom rail of the filter box opening, then push the top of the door against the top of the filter box opening and secure with a sheet metal screw.

Wiring

Before beginning any wiring, study the appropriate wiring diagram for your unit. It is your responsibility to follow all state and local electrical codes. Locate the best place to route the power for the blower, and drill a 7/8" hole in the filter box. This hole size will accommodate a "romex" connector. Attach the blower and power wires as shown on the appropriate wiring diagram.

It is your responsibility to follow all local and state codes for wiring and installation.

Once you have the plenum installed, the fan control with high limit switch can be installed. The Fan control/high limit switch is packaged with a

jumper between the two sets of terminals inside. REMOVE THE JUMPER WIRE INSIDE THE FAN CONTROL. The fan control should be installed in the right side of the plenum and 12 to 18 inches above the top of the furnace. A separate conduit should be run from the fan control to the junction box.

Mount the thermostat in a central location of the area you want to heat. Run two wires to the junction box, from the heating terminals on the thermostat. 22 gauge or thicker wire is acceptable.

The next step is to run a 120 volt line from your breaker panel to the junction box. Attach all wires according to the corresponding wiring diagram, and install the relay into the junction box.

DO NOT TURN ON THE BREAKER UNTIL ALL WIRING IS COMPLETE AND THE RELAY IS SECURED.

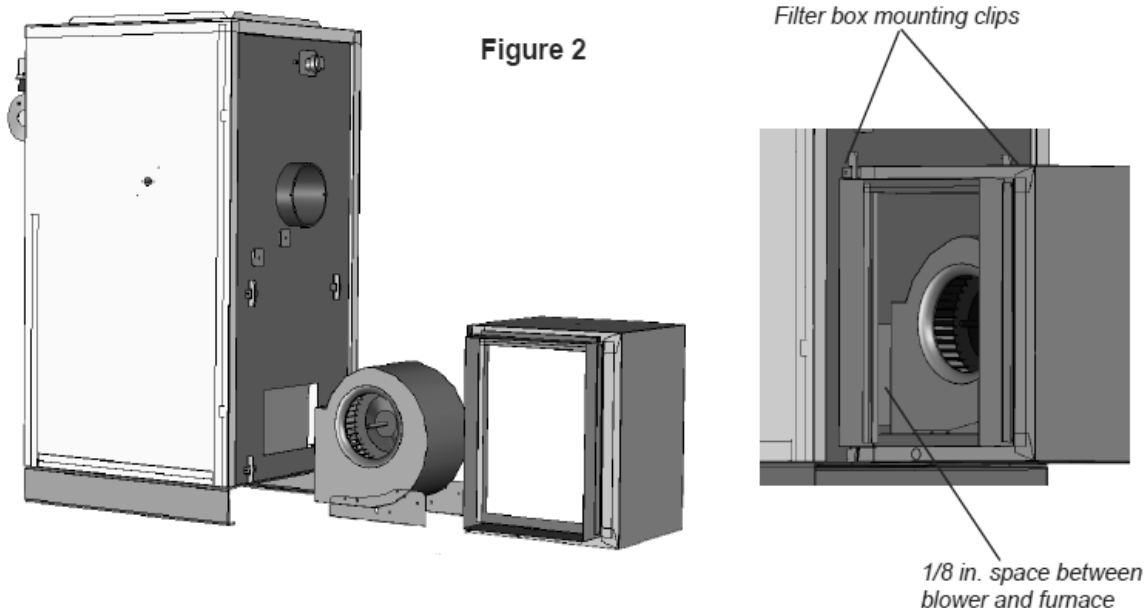

SF1500/SF2500/SF3500 Wiring Diagram

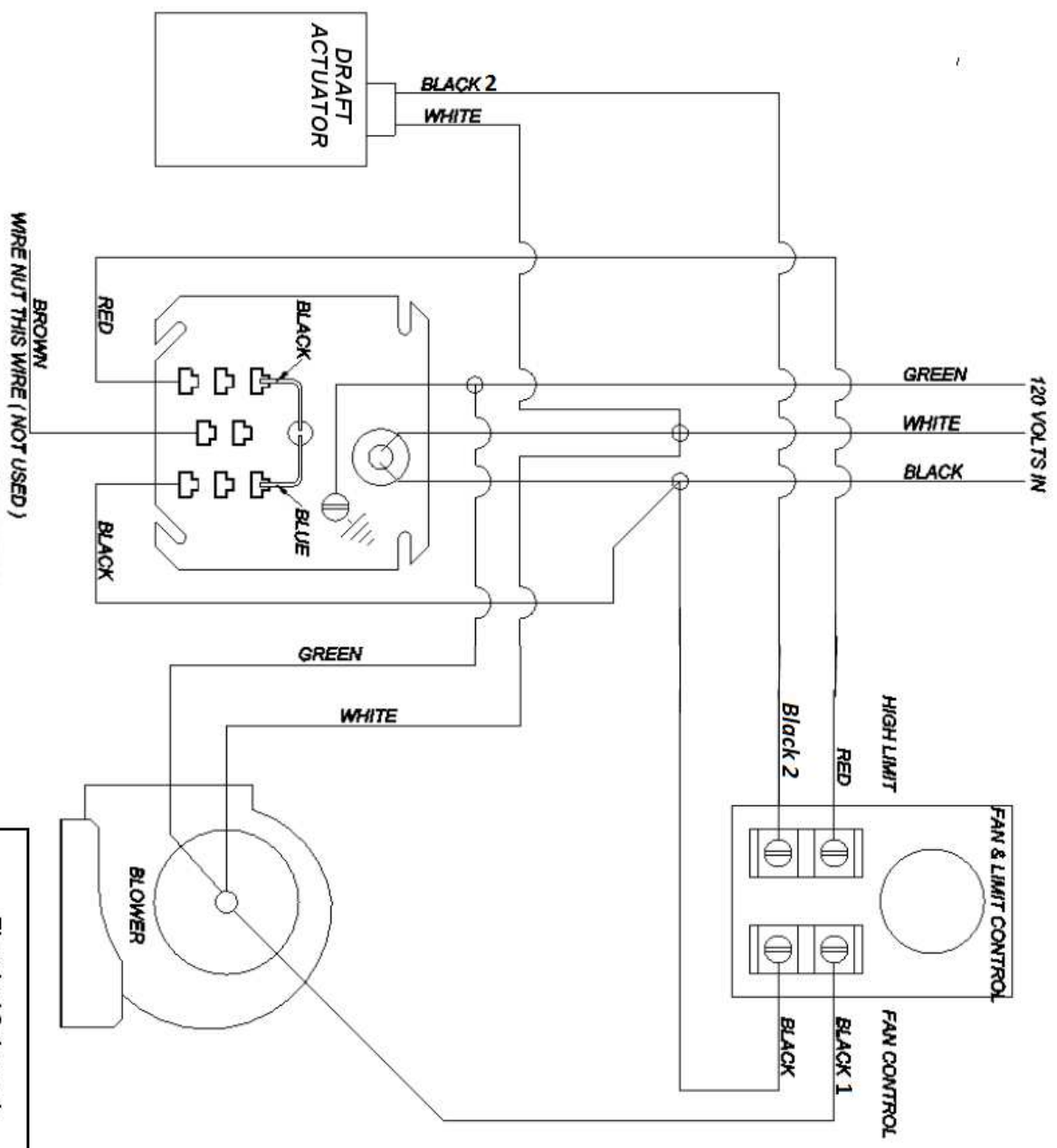
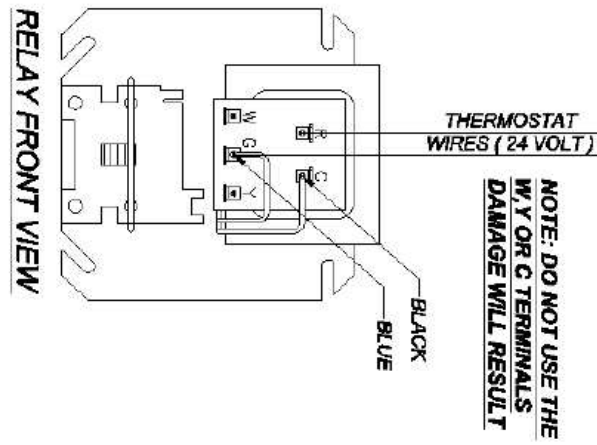
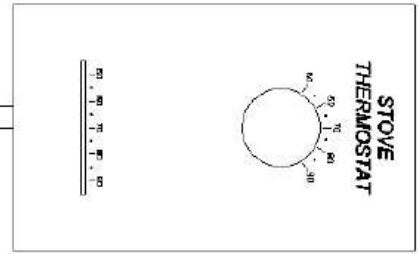

Electrical Schematic
SF1500/SF2500/SF3500
Oct 1, 2015

Duct Work

Duct Work

This figure shows a typical duct system layout. Be sure the entire system is properly sized to provide the correct static pressure for optimum blower performance. Have any new duct system designed by a HVAC professional.

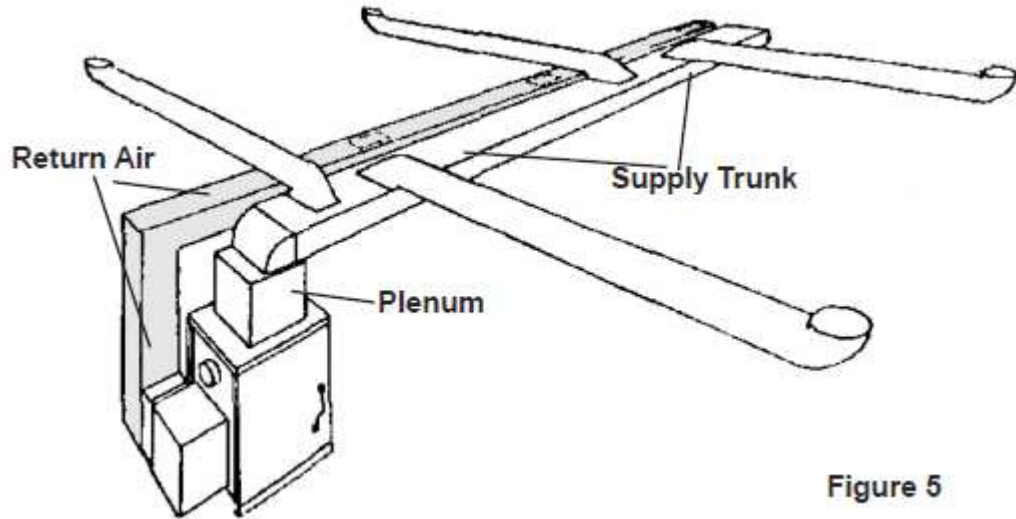

Figure 5

Operating Instructions

Controls

Thermostat

Set the thermostat to the desired temperature. When more heat is needed, the thermostat opens the automatic draft control flapper door. This allows air into the firebox, which raises the output of the fire. When the temperature in the plenum reaches the set temperature of the center pointer on the fan control, the blower will begin blowing heated air through the ductwork. When the thermostat reaches its setpoint, the automatic draft control closes the flapper door, thus, reducing the output of the fire. As the temperature in the plenum drops to the set point of the left pointer on the fan control, the blower will stop. A solid fuel fire cannot cease output immediately, therefore your room temperature may exceed the thermostat setting at times. You also may notice times that the blower runs for a short period even though the draft control is closed. Again, you can't just stop a wood or coal fire instantly, and temperature may build enough to run the blower. This is normal and will be noticed more with coal than with wood.

Adjusting Automatic Draft Control

In order for your new furnace to function, the controls must be properly adjusted. The heat output is regulated by the automatic draft control, on the bottom door of the furnace. Refer to the illustrations that follow; The electric draft motor (A) opens and closes the flapper door (B). The flapper door opens to feed more air to the fire and closes to reduce the air to the fire. The maximum air flow can be adjusted by turning the adjuster bolt (C) counter-clockwise for more air and clockwise for less air. NOTE: To preserve motor life, all adjustments of this bolt should be done while the flapper door is in the closed position. The idle adjuster (D) controls the minimum amount of air that enters the firebox when the flapper door is closed. Adjustment is made by turning the adjuster vertical for zero air, or horizontal for maximum idle air. It is best to start at a medium setting as shown in Figure 6.1.

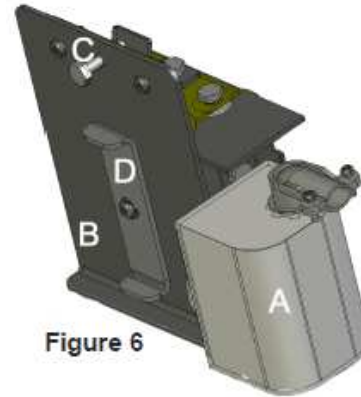

Figure 6

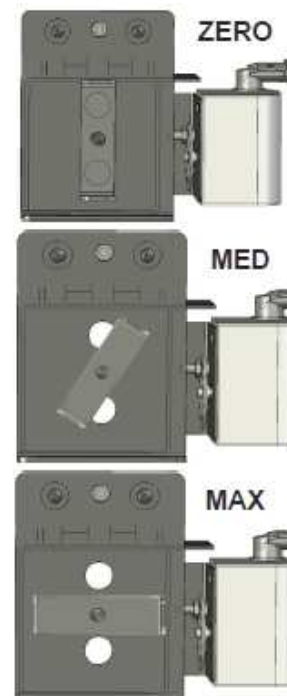

Figure 6.1

CAUTION! THE OPERATION RANGE OF THE AIR CONTROLS MAY NOT BE ALTERED FOR ANY REASON



Adjusting the fan control

Shut off the power at the circuit breaker before removing the fan control cover. Make sure the copper jumper (circled below) is removed before using the furnace. Note the three pointers on the dial. The one on the right is the high limit adjustment. Preset at 200 degrees, it's function is to close the automatic draft control flapper door if the temperature in the plenum reaches 200 degrees. Do not change this setting. The center pointer adjusts the temperature at which the blower starts. A good initial setting for this is 150 degrees. The pointer on the left is to adjust the temperature at which the blower stops. A good initial setting for this pointer is 100 to 110° F. If it is set too low, the air will feel cool coming out of the registers at the end of the blower cycle.



Figure 7

Startup

Curing Paint

During the first few hours of burning, a blue smoke will be observed rising from the painted surface of the furnace. It is advisable to increase the amount of fresh air in the room during this breaking-in period. This may be achieved by opening doors, windows, etc. Don't be alarmed. This is normal.



CAUTION! THE MANUAL DRAFT CONTROLS ARE HOT! USE THE REMOVABLE SHAKER HANDLE OR GLOVES TO ADJUST THESE CONTROLS!



Wood vs Coal

The conditions required for burning the two fuels efficiently are somewhat different. With coal the combustion air must be drawn up through the bed of coal. Wood burns more efficiently with a greater percentage of air feeding over the top of the fire as when compared to coal. Ideally, live wood embers would be positioned in the center of a wood fire to maintain a higher temperature for most efficient combustion. The manual draft controls allow more top feed of air, but they do not automatically close on temperature rise. Ideally, they should be adjusted to allow for sufficient air-flow to keep a flame going and to avoid a smoldering fire at low fire, while at

the same time not burning at such a high rate the home is not too warm. Moisture content of the wood, and how finely it is split, will determine your success in maintaining a controlled, open flame. When there is a call from your thermostat for more heat, the draft control/forced draft fan can then provide the boost of underfed air to increase the rate of firing. Be sure to review the best burn practices section in the beginning of the manual on this topic.



Fuel Capacity

When loading with coal, it is recommended that coal not be piled higher than the firebrick on the sides and back of the firebox. Coal may be loaded as high as possible in the center of the firebox, subject to the limitation that piling it too high will result in it being higher than recommended on the sides. Coal or wood must never be loaded so deeply that there is a risk of it tumbling out the load door.

Starting a Wood Fire

Place seven or eight sheets of crumpled newspaper or similarly suitable paper onto the top of the grates. Next, lay in some very dry, small kindling wood (approximately 3/4" or less) on top of the newspaper. Layer the kindling in a cross-cross fashion to allow for maximum air flow through the material. Light the paper nearest the center of the door opening. Once the paper is lit, you may partly close the door, leaving it slightly ajar to provide additional combustion air. The ash door may be left open initially as well. Add a few small pieces of firewood when the kindling is burning well.

Note: Legacy Stoves hot air furnaces are not EPA approved for continuous firing with wood. Only use wood for preparation for a coal fire.



Manual Draft Controls

Note: Open manual draft controls by turning them counter-clockwise. Close them by turning them clockwise.

The next step will depend on whether you are using the automatic draft control, or forced draft option. If you are using the draft control, close the ash door and load door, and allow air to enter from the draft control. It will feed the fire by flowing upward through the grate.

If you use the forced draft option for starting your fire, close off other air inlets, such as the manual controls on the load door, or you may push smoke into the furnace room. Once the large pieces of wood are burning, the fire can be topped off with the amount of wood you anticipate needing to create a good bed of burning coals for coal ignition.



REMOVAL OR MODIFICATION OF GRATE SYSTEM MAY CAUSE A DANGEROUS SITUATION

Starting A Coal Fire

To start a coal fire, first start the fire with wood as previously described. Do not rush through the process of start-up with wood. Allow sufficient time to establish a hot bed of burning charcoal before switching to coal. Once the wood fire is well

established, and a bed of burning charcoal is forming in the bottom of the firebox, add a layer of coal to the fire. Only add a shallow depth (approximately two inches) of coal at first. Make sure at this point that the air supplied to the fire is coming from underneath, through the automatic draft control, or forced draft fan or an open ash door. Make sure plenty of air is feeding the fire from underneath. As signs of coal ignition appear, consisting mainly of evidence of flame, an additional layer of coal may be added. Layers can be added until the bed is about 10 inches deep, as long as you do not add too much coal at once.

Loading Additional Coal

Coal should not be added unless there is a reasonably hot fire. The coal bed should be bright and vigorously burning. If the fire is burning hot and there is a deep bed of coals, full loads of coal can be added at any time. However, if there is not a deep bed of coals, it is best to add small amounts of coal at first.

Maintaining a Coal Fire

The coal in an operating coal furnace needs to have some depth of unburned coal in order to maintain a fire. If you are new to burning coal, you may underestimate the amount of required depth. In addition, since the fire burns from underneath, instead of on top as for wood, it can be challenging to estimate the depth of unburned coal that is in the firebox. If the fire has begun to fade and weaken in vigor, do NOT shake the grates. Add only a small amount of coal at first, and provide abundant air from underneath in order to help it recover. To boost this recovery, you may even want to open the ash door and watch and wait for the fire to gain sufficient vigor. Once the fire begins to recover, you may then shake the grates and/or add more coal. If you lose the fire, it is likely that the grates were shaken too much too soon, or too much coal was added to a lazy fire. Be sure to close the ash door once the fire has recovered.

Note: Once the fire has faded, it is easy to smother it by adding too much coal too fast, or to lose the fire by shaking the grates. Only shake the grates when the fire is burning well.

If the fire has gone out, shake the grates to remove most (but not all) of the ash. When you start to see tiny pieces of black coal, stop shaking. You can then build a wood fire right on top of the coal that remains, and start the process over again.

Shaking

Shaking should be done only when there is a well-established fire. The frequency of shaking will depend on the degree of burning. Shaking should be done whenever the furnace is refueled. Best results for shaking Legacy Stoves grates will occur when short choppy strokes are used rather than long even strokes. The amount of shaking is critical. Too much will disrupt the fire bed and too little will restrict the air flow. The proper amount normally occurs when tiny red coals first start to drop through the grates into the ash pan.

Note: Ashes should be placed in a metal container with a tight fitting lid. The closed container of ashes should be placed on a noncombustible floor or on the ground, well away from all combustible materials, pending final disposal. If the ashes are disposed of by burial in soil or otherwise locally dispersed, they should be retained in the closed container until all cinders have thoroughly cooled.

Ashes

Ashes should never be allowed to accumulate in the ash area, such that they impede the flow of combustion air to the fire. Excess ash accumulation can cause the fire to go out and also can cause severe damage to the grates because of the absence of a cooling flow of air beneath them.

CAUTION! ASHES SHOULD NEVER BE ALLOWED TO ACCUMULATE ABOVE THE TOP OF THE ASH PAN. ASHES IN CONTACT WITH THE BOTTOM OF THE GRATES ACT AS AN INSULATOR, INTENSIFYING THE HEAT ON THE GRATES, AND COULD CAUSE THEIR WARPAGE. WITH AN EXCESSIVE ASH BUILDUP, PRIMARY COMBUSTION AIR IS RESTRICTED. THUS THE UNIT'S OUTPUT COULD BE REDUCED.

Coal produces considerably more ash than wood. So the intervals between emptying of ash are much shorter. For equal heat output, coal will produce seven to ten times more ash than wood.

Draft Control Settings

The idle air adjustment on the flapper door may need to be adjusted slightly less for coal than for wood. Here again, experience will dictate the best setting. The maximum air adjustment bolt can be set at the maximum position for quick recovery. When a longer than normal burn time is desired, the maximum air adjustment can be reduced. Never adjust the maximum air bolt when the flapper door is opened. See Fig. 6, earlier in the manual.

Note: Grates that have sagged or warped are not covered under warranty. Any damage of this type is caused by allowing ash to build up underneath, blocking air-flow that cools the grates and prevents warping.

Grates

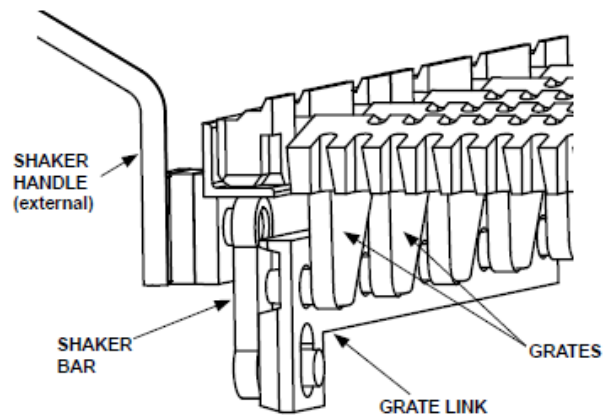

Close-up view of grate system components

The Grates are made of heavy-duty cast iron. The function of the grate system is to support the coal while allowing air flow through the fire. The grate system also allows removal of the ashes by shaking them through the grates. The grates are removable without the use of tools. It is first necessary to remove the fire bricks. Once they are removed, the grates simply lift out. Lift the right end higher to disengage from the shaking link. To re-install the grates, lower them, one at a time, left end first, be sure the grate hooks into the grate link as you drop it into place.

Note: Warped grates are not covered under warranty. This type of failure is due to leaving ash build up underneath the grates.

Your grates will last forever, as long as you keep your ashes cleaned out of the stove. When ashes are left to pile up against the underside of the grates, the air-flow is blocked. With no air flow through the grates, they will begin to sag from the intense heat. The grates are designed to accommodate three different sizes of anthracite coal. Pea is defined as being able to fit through a round screen hole of 9/16" to 7/8". Nut or Chestnut is defined as being able to fit through a round screen hole of 7/8" to 1½". Finally, Stove coal which is 1½" to 2½" in size. Pea or Nut you'll find work the best for starting a fire, while all three sizes burn just as well. The external shaker handle allows for greater safety from burns, and the convenience of needing no extra tools.

Other General Operating Guidelines

Be sure children are advised of the danger of furnaces, and kept away from your furnace, unless attended. Always keep clothing like boots, shoes, mittens, hats and coats at least 3 feet away from the appliance. Never let unsupervised children operate a furnace.

Keep kindling wood and logs at least 3 feet away from the furnace.

NEVER use any liquid fire starter or highly flammable substance to light your furnace.

ALWAYS instruct small children to stay away from the boiler while you are lighting it.

ALWAYS check for combustible materials around your appliance before leaving the house or going to bed at night and remove immediately.

DO NOT BURN GREEN WOOD in your furnace. You will be wasting fuel and increasing the

danger of a chimney fire due to large amounts of creosote produced by green wood. You can get as much as 40% more heat from a log simply by letting it dry out. Dry wood is much more effective for starting coal fires.

The best type of fuel for your Legacy Stoves furnace is anthracite coal in the nut size. Larger coal may result in more air flow than is desired and difficulty in controlling the fire. Continuous operation on coal will limit the buildup of creosote in the stovepipe. Exhaust produced by burning Anthracite coal will chemically react with creosote and loosen it from the chimney liner and flue connecting pipe. You can then easily remove this material from the pipe and the chimney cleanout.

If you have a metal chimney, tap it from time to time and listen for a loose rattling. If audible, this sound indicates that fly ash or creosote is building up. Cleaning the chimney and/or connecting pipe is required.

Operation During a Power Failure

Without electrical power, only natural convection is available to remove heat from the furnace. Draft controls must be set so that natural convection is sufficient to prevent overheating under these circumstances. Alternately, backup power may be used to power the combustion controls, forced draft fan (if present), and hot air distribution. This is the best option for providing continued heating during an extended outage. Whatever means are used, it is important that the system works even when unattended to guard against overheating. Backup power must be provided in a way that satisfies local code requirements and prevents backfeeding of electricity into the power grid.

Note: If backup power is provided by a generator, always operate the generator well outside the home to avoid carbon monoxide in the home.

Maintenance

Spiral Chamber

The spiral chamber is basically self-cleaning. However, if there is a draft problem and you have been burning wood for an extended time with little heat demand, the spiral chamber may need cleaning. Soft coal will also require more frequent cleaning. To clean, remove furnace pipe and scrape the creosote from the front and top of the chamber and remove. The rear of the chamber will not accumulate creosote.

Note: Legacy Stoves hot air furnaces are not EPA approved for continuous firing with wood. Only use wood for preparation for a coal fire.

Firebricks

Firebricks may become cracked during the course of normal operation. A cracked brick that is still in place is still doing its job and need not be replaced immediately. If a brick is broken and has fallen out of place, it should be replaced immediately. The firebrick used in the Legacy Stoves furnaces are inexpensive and easy to replace.

The blower manufacturer recommends the blower motor to be oiled once a year with 10 to 20 drops of light weight oil [check instructions packed in blower box).

Specifications

	SF1500	SF2500	SF3500
Heating Capacity – square ft. (approximately)	2200	3200	4200
Approximate BTU Input	90,000	120,000	170,000
Blower Size ²	1450 cfm ^{1,2}	1450 cfm ^{1,2}	1450 cfm ²
Automatic Draft	Standard	Standard	Standard
Filter Box & Filter ²	Required ²	Required ²	Required ²
Fan Control/ High Limit	Standard	Standard	Standard
Thermostat	Standard	Standard	Standard
Domestic Hot Water Coil	Optional	Optional	Optional
Firebox Dimensions	16Wx22Lx20.5H	18Wx26Lx21.5H	18Wx30Lx25H
Recommended Log Length	18 in.	22 in.	27 in.
Flue Size	6 in.	7 in.	7 in.
Filter Size	14 X 20 X 1	14 X 20 X 1	14 X 20 X 1
Number of Grates	4	5	6
Weight	580 lbs.	700 lbs.	800 lbs.
Plenum Dimensions	20 X 20	20 X 20	20 X 25
Clearance to Combustibles – Rear	30 in.	30 in.	30 in.
Clearance to Combustibles – Side	24 in.	24 in.	24 in.
Electrical Rating	115V/8A	115V/8A	115V/9A
Dimensions:			
A:	25 in.	26 in.	28 in.
B:	20 in.	20 in.	20 in.
C:	46.5 in.	47.5 in.	52.5 in.
D:	27.75 in.	31 in.	36 in.
E:	20 in.	20 in.	25 in.
F:	40 in.	41.75 in.	45 in.
G:	16.5 in.	16.5 in.	16.5 in.
H:	44.5 in.	47.5 in.	52.5 in.
K:	27.5 in.	27.5 in.	27.5 in.

¹Includes restrictor plate to reduce air-flow

²Priced and sold separately

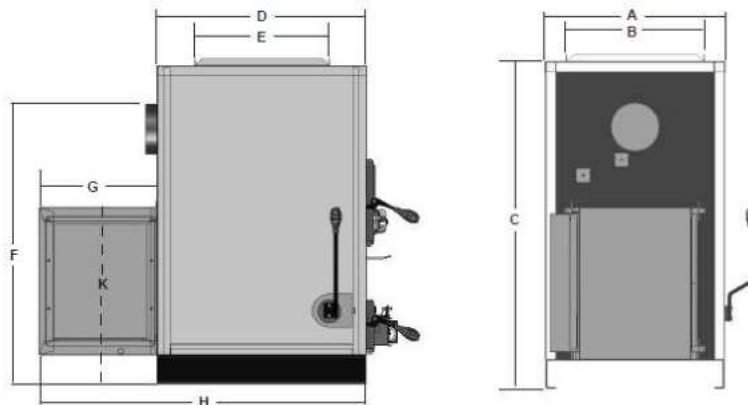

Special Instructions

Coil installation

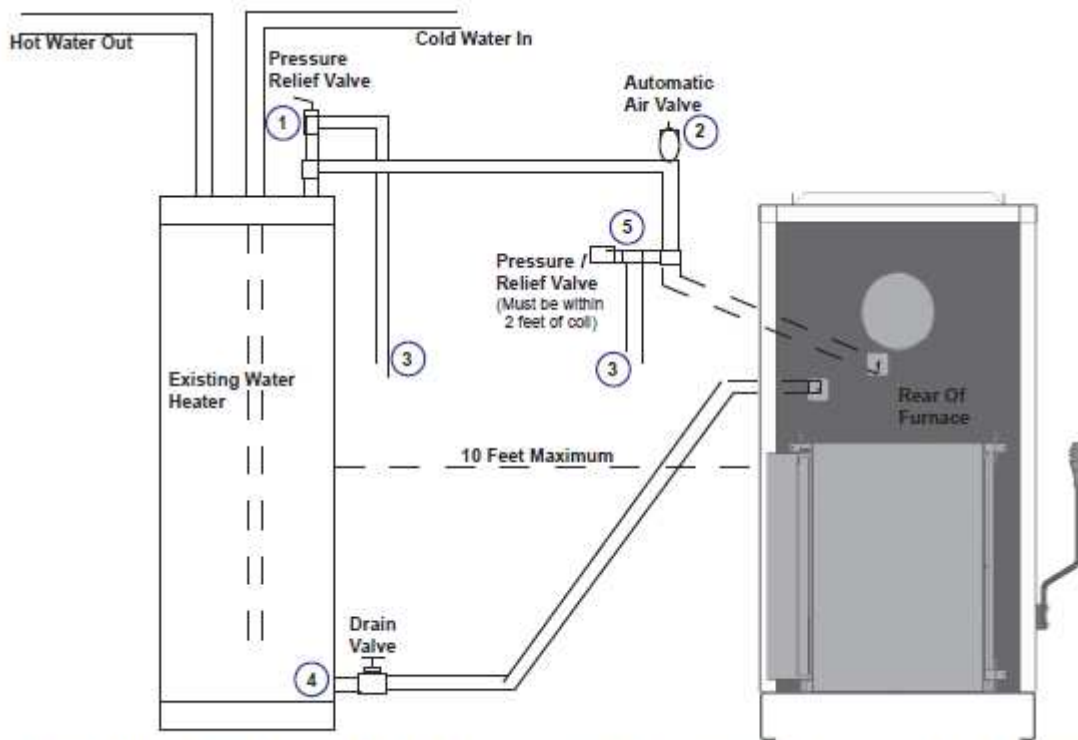

Plumbing Diagram For Thermo-Siphon Method - Maximum Distance = 10 Feet

Place one of the supplied nuts on each leg of the coil. Place the coil through the holes on the back of the furnace, and adjust the nuts so that the pipes stick out about $1\frac{1}{4}$ to $1\frac{1}{2}$ inches from the rear of the furnace. Place the flat washers and gaskets over each pipe and tighten the nuts. You are now ready to run the piping.

This simple method is the most economical. However, the existing water heater must be less than 10 feet from the furnace. The water inlet, where the Temperature / Pressure Relief valve is located, must be higher than the top leg of the water coil. The water heater should be elevated, if necessary, to allow for proper thermosiphon action. (The method by which hot water will circulate automatically through the system.)

- A. Shut off the water heater and the water supply to it. Drain the tank completely.
- B. Remove the Temp. / Pressure relief valve and discard. Install a short $3/4$ in. nipple and tee (1) along with a new relief valve.
- C. run $3/4$ in. copper tubing between the water tank and the top leg of the coil. Install a $3/4$ in vent elbow and automatic "float type" air vent (2) in the high point of the line. Within 2 feet of the top leg of the coil, install a 150 lb. pressure relief valve (5). Run $3/4$ in. tubing from the release exit of both relief valves downward (3) so the hot water can escape in the event of an overheat situation.
- D. Remove the drain valve, at the bottom of the tank. Install a short $3/4$ in. nipple and tee and re-install the drain valve to the tee (4). Run $3/4$ in. tubing between the drain / tee combination and the lower leg of the water coil. After all of the connections are secured, refill the water tank. *Turn on the water heater only after the tank has been completely refilled.*

Special Instructions

Coil Installation

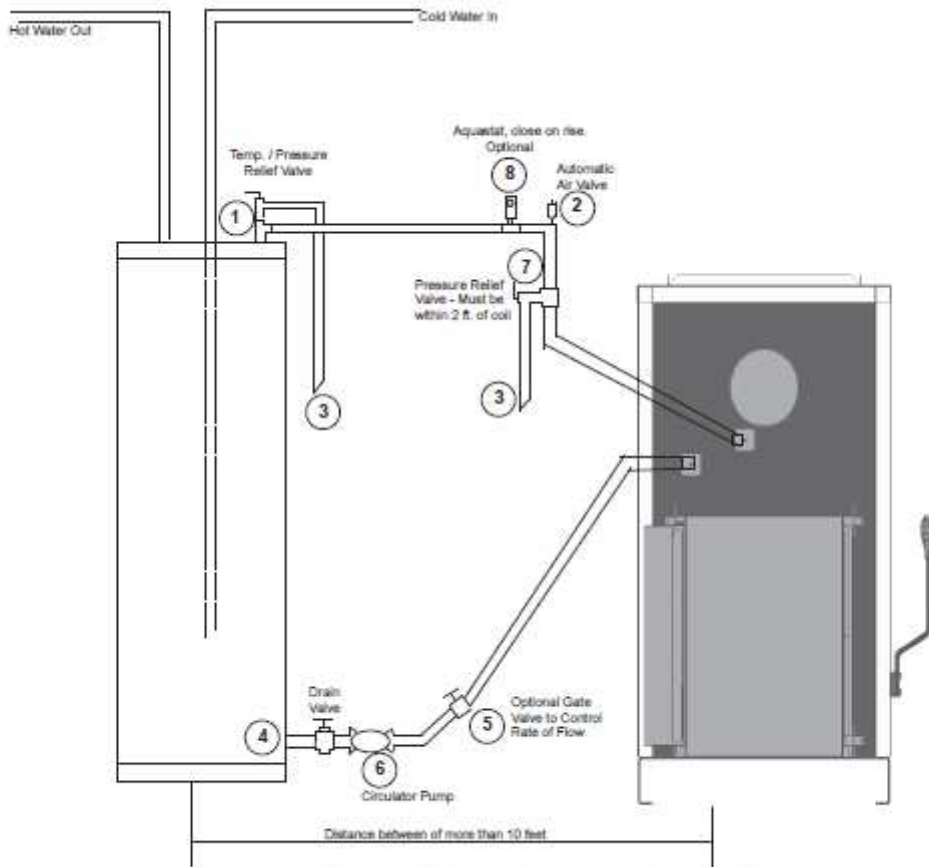

Circulating Pump Method - Distance = 10 Feet or More

This method is used when the water heater tank is more than ten feet away from the furnace or the furnace is on a higher level than the water heater tank. In addition to a circulator pump, you may want to add an aquastat to thermostatically control the pump according to water temperature. This is optional and not necessary if the circulator pump is left run continuously. Another option is a gate valve placed near the pump to control the rate of water flow.

A. Shut off the water heater and the water supply to it. Drain the tank completely.

B. Remove the Temp. / Pressure relief valve and discard. Install a short 3/4 in. nipple and tee (1) along with a new relief valve.

C. Remove the drain valve, at the bottom of the tank. Install a short 3/4 in. nipple and tee and re-install the drain valve to the tee (4).

D. Install a circulator pump as shown (6). Run 3/4" copper tubing from the circulator pump to the lower leg of the water coil. This is where the optional gate valve (5) can be installed to regulate flow.

E. Install a 3/4 in. tee and a 150 lb. Pressure relief valve (7) in the top leg within two feet of the coil.

F. Complete the 3/4 in. line by running it back to the tee at the top of the water heater tank. Be sure to install the 3/4 in. vent elbow and automatic air vent (2) at the high point of the line. The optional aquastat can be installed in this line, a maximum of 6 feet from the furnace. This aquastat must close on rise in temperature and must be hooked up to turn on the circulator when the water temperature reaches 120° f.

G. After securing all connections, refill the tank with water and then, ONLY THEN, turn on the power to the water heater.

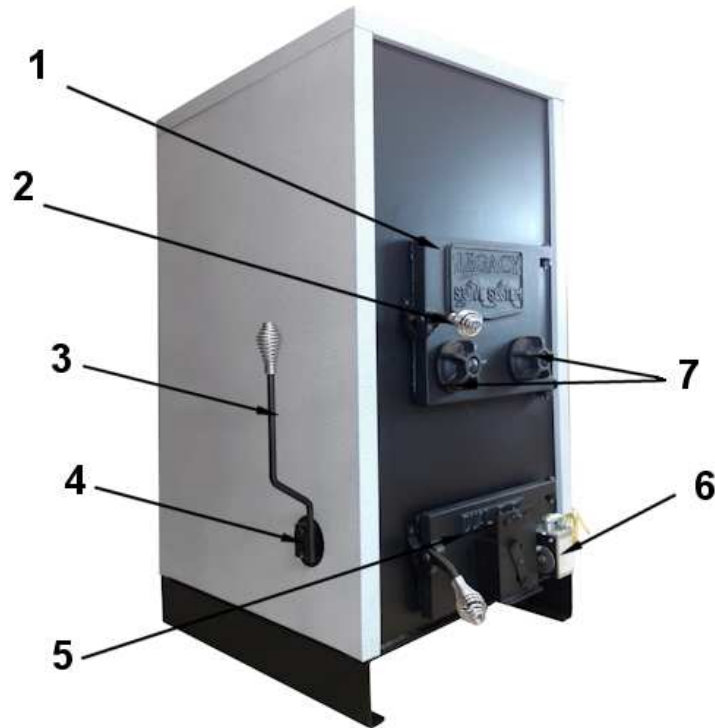

IMPORTANT: THIS IS DATED INFORMATION. Parts must be ordered from a dealer or distributor. Legacy Stoves does not sell directly to consumers. Provide model number and serial number when requesting service parts from your dealer.

ITEM	DESCRIPTION	COMMENTS	PART NUMBER
1	Load Door - Cast		4-00-00197P
	Door Latch	4 Sets	1-00-00036
	Gasket - 1/2½ Rope (Load Door & Ash Door)	20 Ft	1-00-53500
2	Door Handle - Cast (not as shown in picture)	Qty 2 req	4-00-00042
3	Long Shaker Handle Weldment		1-10-01005
	Shaker Bar Weldment - 5-3/16½		1-10-00668W
	Shaker Block		2-00-01037-1
	Shaker Bracket		2-00-04129F
4	Shaker Handle Mount		2-00-01037-2
5	Ash Door - Cast		4-00-00200-1D
	Ash Pan		1-10-16027
6	Automatic Draft Control Assembly		1-10-03375
	Draft Control Motor Mount Bracket		2-00-01010B
	Draft Motor - 120v		3-20-45338
7	Draft Control – Cast	Qty 2 req	4-00-00109-1

Parts list continues on next page

Service Parts: SF1500 (continued)



IMPORTANT: THIS IS DATED INFORMATION. Parts must be ordered from a dealer or distributor. Legacy Stoves does not sell directly to consumers. Provide model number and serial number when requesting service parts from your dealer.

ITEM	DESCRIPTION	COMMENTS	PART NUMBER
	ADC Cover		2-00-01012P
	ADC Hinge		3-31-01004
	Blower Assembly – 1000cfm (<i>pre-Legacy</i>)		1-10-01006
	Replacement Motor - 1000 cfm blower (<i>pre-Legacy</i>)		3-20-36648
	Blower Assembly – 1450 cfm (<i>Legacy</i>)		1-00-00862
	Restrictor Plate (<i>Legacy, for SF1500/SF2500</i>)		2-00-03152
	Blower Brackets		3-21-22335
	Brick - 9½ X 4-1/2½ x 1-1/4½ (8 needed)	Pkg of 7	1-00-900450125
	Set of Cut Brick		1-00-00839
	Brick - Used with Reducer - 9½ x 4 1/2½ x 2 1/2½		3-40-900450250
	Brick - Full skid	414 Pcs	3-40-900450-414
	Disconnects - Female	Pkg of 25	1-00-00959
	Door Pins - 3/8 x 1 7/8	Qty 4 req	4-30-00138B
	Fan Limit		3-20-23139
	Filter Box		1-10-3291
	Air Filter-Furnace 14 x 20 x 1	Pkg of 12	3-40-14201-12
	Filter Box Mounting Brackets	Qty 4 req	2-00-01003
	Flex Conduit	7 Ft	1-00-25043
	Furnace Kit		1-00-01007-1
	Gasket Glue	32 oz	3-42-4583
	Grate Holder 2 - cast	Qty 4 req	3-00-00193
	Grate Link 4 Hole - cast		4-00-00205D
	Grate 13 in - Cast	(4 needed)	3-00-00207
	Hot Water Coil Hardware		3-10-49000
	.Jacket Side w/o Shaker Hole		2-00-04130-15S
	Jacket Side w/Shaker Hole		2-00-00304-15S
	Jacket Top		2-00-08117-15S
	Relay - Low Voltage		3-20-43393
	Spring Handles	Pkg of 3	3-40-00086-3-3
	Steel Box - 4 x 4		3-20-52171
	Straight Hot Water Coil		3-10-49201
	Coil Hole Plate	Qty 4 req	2-00-04123L
	Thermostat - Low Voltage		3-20-12080
	Toggle Switch - 3 Speed (<i>pre-Legacy</i>)		3-20-70020
	Touch up Paint - Aerosol		3-42-7737

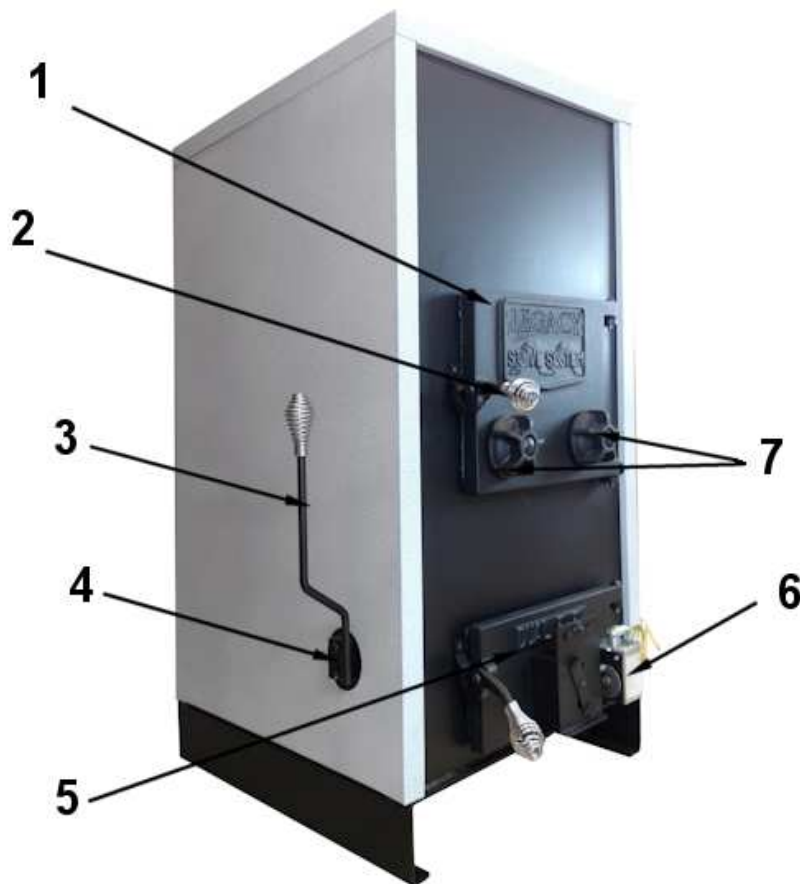

IMPORTANT: THIS IS DATED INFORMATION. Parts must be ordered from a dealer or distributor. Legacy Stoves does not sell directly to consumers. Provide model number and serial number when requesting service parts from your dealer.

ITEM	DESCRIPTION	COMMENTS	PART NUMBER
1	Load Door - Cast		4-00-00197P
	Door Latch 4 Sets		1-00-00036
	Flapper Weldment 18-3/8½		1-10-00674W
2	Door Handle - Cast (not as shown in picture)	Qty 2 req	4-00-00042
3	Long Shaker Handle Weldment		1-10-01005
4	Shaker Handle Mount		2-00-01037-2
	Shaker Bar Weldment		1-10-02016W
	Shaker Block		2-00-01037-1
	Shaker Bracket		2-00-01047F
5	Ash Door - Cast		4-00-00200-1D
	Ash Pan		1-10-25027
6	Automatic Draft Control Assembly		1-10-03375
	Draft Control Motor Mount Bracket		2-00-01010B
	Draft Motor - 120v		3-20-45338
7	Draft Control - Cast		4-00-00109-1

Parts list continues on next page

Service Parts: SF2500 (continued)



IMPORTANT: THIS IS DATED INFORMATION. Parts must be ordered from a dealer or distributor. Legacy Stoves does not sell directly to consumers. Provide model number and serial number when requesting service parts from your dealer.

ITEM	DESCRIPTION	COMMENTS	PART NUMBER
	ADC Cover		2-00-01012P
	ADC Hinge		3-31-01004
	Blower Assembly – 1000cfm (<i>pre-Legacy</i>)		1-10-01006
	Replacement Motor 1000 cfm blower (<i>pre-Legacy</i>)		3-20-36648
	Blower Assembly – 1450 cfm (<i>Legacy</i>)		1-00-00862
	Restrictor Plate (<i>Legacy, for SF1500/SF2500</i>)		2-00-03152
	Blower Leg Set		3-21-22335
	Brick 9½ X 4-1/2½ x 1-1/4½ (10 needed)	Set of 7	1-00-900450125
	Set of Cut Brick		1-00-00841
	Brick - 9½ x 4-1/2½ x 2-1/2½ (for use with Reducer)		3-40-900450250
	Brick - Full Skid	414 Pcs	3-40-900450-414
	Disconnect - Female	Pkg of 25	1-00-00959
	Door Pins - 3/8 x 1-7/8		4-30-00138B
	Fan Limit		3-20-23139
	Filter Box - Furnace		1-10-3291
	Air Filter-Furnace 14 x 20 x 1	Pkg of 12	3-40-14201-12
	Flapper Hook	Qty 2 req	2-00-01005B
	Flex Conduit	7 Ft	1-00-25043
	Furnace Filter Box Clip	Qty 4 req	2-00-01003
	Furnace Kit		1-00-01007-1
	Gasket 1/2½ Rope (Load Door - Ash Door)	20 FT	1-00-53500
	Gasket Glue - 32 oz		3-42-4583
	Grate 13 in - Cast (5 needed)		3-00-00207
	Grate Holder 2 - Cast	Qty 2 req	3-00-00193
	Grate Holder 3 - Cast	Qty 2 req	3-00-00194
	Grate Link 5 - Cast		3-00-00205
	Hot water Coil Hardware		3-10-49000
	Jacket side w/o Shaker Hole		2-00-07004-15S
	Jacket Side w/Shaker Hole		2-00-00402-15S
	Jacket Top		2-00-08130-15S
	Relay - Low Voltage		3-20-43393
	Spring Handle	Pkg of 3	3-40-00086-3-3
	Steel Box - 4 x 4		3-20-52171
	Straight Hot Water Coil		3-10-49201
	Coil Hole Plates	Qty 4 req	2-00-04123L
	Thermostat - Low Voltage		3-20-12080
	Toggle Switch - 3 Speed (<i>pre-Legacy</i>)		3-20-70020
	Touch-up Paint - Aerosol	Qty 4 req	3-42-7737

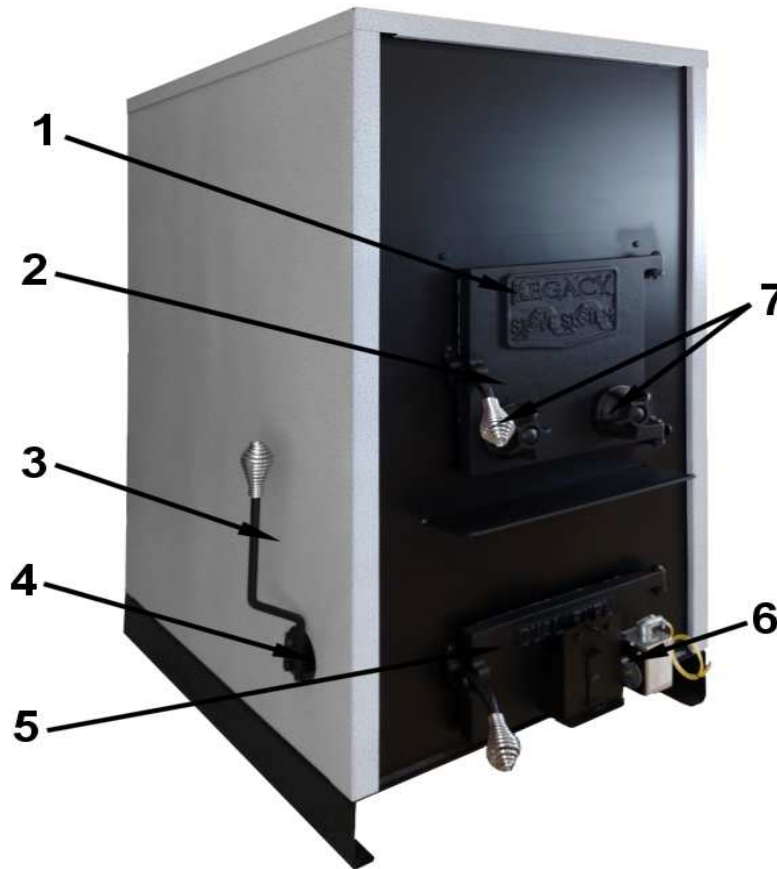

IMPORTANT: THIS IS DATED INFORMATION. Parts must be ordered from a dealer or distributor. Legacy Stoves does not sell directly to consumers. Provide model number and serial number when requesting service parts from your dealer.

ITEM	DESCRIPTION	COMMENTS	PART NUMBER
1	Load Door - Cast		4-00-00195P
	Door Latch 4 Sets		2-00-00036B
	Flapper Weldment 18-3/8½		1-10-00674W
2	Door Handle - Cast (not as shown in picture)	Qty 2 req	4-00-00042
3	Long Shaker Handle Weldment		1-10-01005A
4	Shaker Handle Mount		2-00-01037-2
	Shaker Bar Weldment		1-10-02016W
	Shaker Block		2-00-01037-1
	Shaker Bracket		2-00-01047F
5	Ash Door - Cast		4-00-00200-1D
	Ash Pan		1-10-35027A
6	Automatic Draft Control Assembly		1-10-03375
	Draft Control Motor Mount Bracket		2-00-01010B
	Draft Motor - 120v		3-20-45338
7	Draft Control - Cast		4-00-00109-1P

Parts list continues on next page

Service Parts: SF3500 (continued)



IMPORTANT: THIS IS DATED INFORMATION. Parts must be ordered from a dealer or distributor. Legacy Stoves does not sell directly to consumers. Provide model number and serial number when requesting service parts from your dealer.

ITEM	DESCRIPTION	COMMENTS	PART NUMBER
	ADC Cover		2-00-01012P
	ADC Hinge		3-31-01004
	Blower & Motor – 1450 cfm		1-00-00862
	Blower Leg Set		3-21-22335
	Brick 9½ X 4-1/2½ x 1-1/4½ (10 needed)	Set of 7	1-00-900450125
	Set of Cut Brick		1-00-00844
	Brick - 9½ x 4-1/2½ x 2-1/2½ (for use with Redu		3-40-900450250
	Brick - Full Skid	414 Pcs	3-40-900450-414
	Disconnect - Female	Pkg of 25	1-00-00959
	Door Pins - 3/8 x 1-7/8		4-30-00138B
	Fan Limit		3-20-23139
	Filter Box - Furnace		1-10-3291A
	Air Filter-Furnace 14 x 20 x 1	Pkg of 12	3-40-14201-12
	Flapper Hook	Qty 2 req	2-00-01005B
	Flex Conduit	7 Ft	1-00-25043
	Furnace Filter Box Clip	Qty 4 req	2-00-01003
	Furnace Kit		1-00-01007-1
	Gasket 1/2 IN Rope (Load Door - Ash Door)	20 FT	3-44-53500
	Gasket Glue - 32 oz		3-42-4583
	6 HOLE GRATE LINK - CAS		3-00-00206
	LONG GRATE 15IN-CAST		3-00-00208
	Grate Holder 2 - Cast	Qty 2 req	3-00-00193
	Grate Holder 3 - Cast	Qty 2 req	3-00-00194
	Grate Link 5 - Cast		3-00-00205
	Hot water Coil Hardware		3-10-49000
	Relay - Low Voltage		3-20-43393
	Spring Handle	Pkg of 3	3-40-00086-3-3
	Steel Box - 4 x 4		3-20-52171
	Straight Hot Water Coil		3-10-49201
	Coil Hole Plates	Qty 4 req	2-00-04123L
	Thermostat - Low Voltage		3-20-12080
	Touch-up Paint - Aerosol	Qty 4 req	3-42-7737
	Box 4x4 – Steel		3-20-52171

Warranty Information (2 Pages)

Alternate Heating Systems

LIFETIME LIMITED WARRANTY

Alternate Heating Systems, on behalf of its hearth brands ("AHS"), extends the following warranty for Legacy Stoves™ wood and/or coal hearth appliances that are purchased from an AHS Legacy Stoves authorized dealer.

WARRANTY COVERAGE:

AHS warrants to the original owner of the AHS Legacy Stoves appliance at the site of installation, and to any transferee taking ownership of the appliance at the site of installation within two years following the date of original purchase, that the AHS Legacy Stoves appliance will be free from defects in materials and workmanship at the time of manufacture. After installation, if covered components manufactured by AHS are found to be defective in materials or workmanship during the applicable warranty period, AHS will, at its option, repair or replace the covered components. AHS, at its own discretion, may fully discharge all of its obligations under such warranties by replacing the product itself or refunding the verified purchase price of the product itself. The maximum amount recoverable under this warranty is limited to the purchase price of the product. This warranty is subject to conditions, exclusions and limitations as described below.

WARRANTY PERIOD:

Warranty coverage begins on the date of original purchase. In the case of new home construction, warranty coverage begins on the date of first occupancy of the dwelling or six months after the sale of the product by an independent, authorized AHS Legacy Stoves dealer/ distributor, whichever occurs earlier. The warranty shall commence no later than 24 months following the date of product shipment from AHS Legacy Stoves, regardless of the installation or occupancy date. The warranty period for parts and labor for covered components is produced in the following table. The term "Limited Lifetime" in the table below is defined as: 10 years from the beginning date of warranty coverage for wood/coal and coal appliances. These time periods reflect the minimum expected useful lives of the designated components under normal operating conditions.

Warranty Period		AHS Manufactured Appliances and Venting			Components Covered
Parts	Labor	Coal and Wood	Coal	Venting	
1 Year		x	x	x	All parts and material except as covered by Conditions, Exclusions, and Limitations listed
2 years		x	x		Igniters, electronic components, and glass Factory-installed blowers
Limited Lifetime	3 years	x	x		Firebox and heat exchanger
90 Days		x	x	x	All replacement parts beyond warranty period

See conditions, exclusions, and limitations on next page

WARRANTY CONDITIONS:

This warranty only covers AHS appliances that are purchased through an AHS Legacy Stoves authorized dealer or distributor. A list of AHS Legacy Stoves authorized dealers is available on the AHS Legacy Stoves branded websites.

This warranty is only valid while the AHS appliance remains at the site of original installation.

This warranty is only valid in the country in which the AHS Legacy Stoves authorized dealer or distributor that sold the appliance resides.

Contact your installing dealer for warranty service. If the installing dealer is unable to provide necessary parts, contact the nearest AHS Legacy Stoves authorized dealer or supplier. Additional service fees may apply if you are seeking warranty service from a dealer other than the dealer from whom you originally purchased the product.

Check with your dealer in advance for any costs to you when arranging a warranty call. Travel and shipping charges for parts are not covered by this warranty.

WARRANTY EXCLUSIONS:

This warranty does not cover the following:

Changes in surface finishes as a result of normal use. As a heating appliance, some changes in color of interior and exterior surface finishes may occur. This is not a flaw and is not covered under warranty.

Damage to printed, plated, or enameled surfaces caused by fingerprints, accidents, misuse, scratches, melted items, or other external sources and residues left on the plated surfaces from the use of abrasive cleaners or polishes.

Repair or replacement of parts that are subject to normal wear and tear during the warranty period. These parts include: paint, wood, pellet and coal gaskets, firebricks, grates, flame guides, batteries and the discoloration of glass.

Minor expansion, contraction, or movement of certain parts causing noise. These conditions are normal and complaints related to this noise are not covered by this warranty.

Damages resulting from: (1) failure to install, operate, or maintain the appliance in accordance with the installation instructions, operating instructions, and listing agent identification label furnished with the appliance; (2) failure to install the appliance in accordance with local building codes; (3) shipping or improper handling; (4) improper operation, abuse, misuse, continued operation with damaged, corroded or failed components, accident, or improperly/ incorrectly performed repairs; (5) environmental conditions, inadequate ventilation, negative pressure, or drafting caused by tightly sealed constructions, insufficient make-up air supply, or handling devices such as exhaust fans or forced air furnaces or other such causes; (6) use of fuels other than those specified in the operating instructions; (7) installation or use of components not supplied with the appliance or any other components not expressly authorized and approved by AHS Legacy Stoves; (8) modification of the appliance not expressly authorized and approved by AHS in writing; and/or (9) interruptions or fluctuations of electrical power supply to the appliance.

Non-AHS venting components, hearth components or other accessories used in conjunction with the appliance.

Any part of a pre-existing fireplace system in which an insert is installed.

AHS's obligation under this warranty does not extend to the appliance's capability to heat the desired space. Information is provided to assist the consumer and the dealer in selecting the proper appliance for the application. Consideration must be given to appliance location and configuration, environmental conditions, insulation and air tightness of the structure.

This warranty is void if:

The appliance has been over-fired or operated in atmospheres contaminated by chlorine, fluorine, or other damaging chemicals. Over-firing can be identified by, but not limited to, warped plates or tubes, rust colored cast iron, bubbling, cracking and discoloration of steel or enamel finishes.

The appliance is subjected to prolonged periods of dampness or condensation. There is any damage to the appliance or other components due to water or weather damage which is the result of, but not limited to, improper chimney or venting installation.

LIMITATIONS OF LIABILITY:

The owner's exclusive remedy and AHS's sole obligation under this warranty, under any other warranty, express or implied, or in contract, tort or otherwise, shall be limited to replacement, repair, or refund, as specified above. In no event will AHS be liable for any incidental or consequential damages caused by defects in the appliance. Some states do not allow exclusions or limitation of incidental or consequential damages, so these limitations may not apply to you. This warranty gives you specific rights; you may also have other rights, which vary from state to state. EXCEPT TO THE EXTENT PROVIDED BY LAW, AHS MAKES NO EXPRESS WARRANTIES OTHER THAN THE WARRANTY SPECIFIED HEREIN. THE DURATION OF ANY IMPLIED WARRANTY IS LIMITED TO DURATION OF THE EXPRESSED WARRANTY SPECIFIED ABOVE.



**Advanced Design
Old Fashioned Value**

(Signature of Boxer)

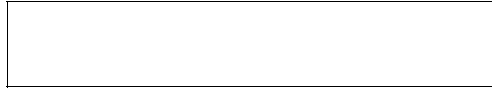

Your premium quality hearth product designed and assembled
by the experienced and skilled members at Alternate Heating
Systems in Harrisonville, PA, USA.