



OWNER'S MANUAL

**MX2™ CONTROL EQUIPPED
WOOD PELLET BURNING HEATER**
* INSTALLATION * OPERATION *
SERVICE * PARTS *

KOZI Previa Free Standing Pellet Stove



⚠ WARNING



HOT SURFACES! Glass and other surfaces are hot during operation and cool down.

Hot glass will cause burns.

- Do not touch glass until it is cooled.
- NEVER allow children to touch glass.
- Keep children away.
- CAREFULLY SUPERVISE children in same room as fireplace.
- Alert children and adults to hazards of high temperatures.
- High temperatures may ignite clothing or other flammable materials.
- Keep clothing, furniture, draperies and other flammable materials away.

U.S. ENVIRONMENTAL
PROTECTION AGENCY
Certified to comply with
2020 particulate emission
standards using pellet fuel.

Manufactured By:
APR Industries Ltd.
1354 Waverley Street
Winnipeg, MB
Canada, R3T 0P5
Ph: (204) 452-9907
Fx: (204) 453-2747
Em: mail@kozistoves.com

CAUTION:

Read all instructions carefully before starting the installation or operating the heater. Failure to follow these instructions could result in property damage, bodily injury or even death. Contact local building or fire officials about restrictions and installation inspection requirements in your area. Save this manual for future reference.



Intertek

Printed in Canada
Revised July 2015

WWW.KOZISTOVES.COM

If you have any questions, comments or concerns regarding your new **KOZI** pellet stove, please contact your local dealer or APR Industries Ltd by phone at (204) 452-9907 or by visiting our website at **WWW.KOZISTOVES.COM**.

CAUTION: Stove has moving parts. Disconnect power before servicing.

Please contact your local building officials (i.e. municipal, building department, fire department, fire prevention bureau, etc.) to determine the need to obtain a permit.

This wood heater needs periodic inspection and repair for proper operation. It is against federal regulations to operate this wood heater in a manner inconsistent with operating instructions in this manual.

The stoves have been found to be in compliance with the following standards:

ULC S628 (1993), ASTM E1509 (2004), ULC S627 (2000), UL 1482 (2011), ULC/ORD C1482 (1990), ASTM E2779 (2010), and ASTM E2515 (2011).

TABLE OF CONTENTS

I. SAFETY FIRST!!!	5
II. STOVE SPECIFICATIONS	7
III. INSTALLATION	7
1. Clearance to Combustibles	7
i. Installation Clearances	7
ii. Other Clearances and Recommendations	9
2. Electrical Requirements	10
3. Fuel Requirements	11
i. Physical Properties	11
ii. Fuel Storage	11
4. Location of the Heater	12
5. Typical Installation Configurations	13
6. Venting System	14
i. Exhaust Vent Pipe Requirements	14
ii. Exhaust Vent Pipe Requirements	15
iii. Combustion Air Intake Requirements	16
7. Mobile Home Additional Installation Requirements	17
i. Typical Mobile Home Installation Configuration	17
ii. Recommendations for Mobile Home Installation	18
iii. Mobile Home Combustion Air Intake Requirements	18
iv. Exhaust Vent Requirements	19
v. Other Mobile Home Installation Requirements	19
IV. OPERATION	19
1. General Overview	19
2. Safety Features	20
3. Electric Igniter	21
4. MX2 TM Controls	21
i. Basic Description	21
ii. “AUTO, HIGH/LOW, MANUAL” Modes	21
iii. “ON/OFF” Button	22
iv. “HEAT SELECT” Button & Bar Graph	22
v. “AUGER” Button	22
vi. “FAN” Button	23
vii. “TRIM” Button	23
viii. Wall Thermostat, Wall Switch or Other Switching Device	23
ix. Damper Control	24
x. Starting Your Heater for the First Time	25

xi. Starting/Lighting your Heater	25
xii. Stopping Your Heater	26
xiii. Adjusting Your Heater	27

V. MAINTENANCE & CLEANING 27

VI. TROUBLESHOOTING GUIDE 33

1. Troubleshooting	33
2. Corrective Actions	34
i. Proof of Flame Failure	34
ii. Pressure Switch Failure	34
iii. Manual Reset Thermal Disk Failure	35
iv. Ignition Failure	35
v. Overheating	35
vi. Lack of Air	36

VII. DIAGRAMS AND PARTS LIST 37

1. KOZI MX2™ Control Circuit Diagram	37
2. Stove Cross Section	38
3. Equipment Compartment	39
4. Parts List	41

VIII. WARRANTY 42

1. Warranty Registration Card	43
-------------------------------	----

I. SAFETY FIRST!!!

This heater is suitable for both mobile home and conventional home installation. Read all instructions carefully before starting installation. Save this manual for future reference.

1. Read these instructions carefully. Failure to follow them could cause a malfunction of the heater, damage to the heater, property damage, bodily injury or even death.
2. Familiarize yourself with the heater's operation (see "Operation" section). If you are not sure, ask your dealer for explanations on your heater's proper operation.
3. The burn pot of this heater is designed to burn premium grade wood pellets. Pellets with too much fines and saw dust must be screened before use. **DO NOT USE WET PELLETS**. Refer to the "Fuel Requirements" section for more information.
4. Oil the circulation fan motor bearings every 6 months. See "Maintenance" section for more details.
5. Check your local building codes regarding restrictions or installation requirements. All installations must comply with local building codes.
6. This heater requires a floor protector beneath the heater and extending a minimum of 6 inches (150 mm) in front and beyond each side of the fuel loading and ash removal openings of the heater. This is to catch any spillage which may occur during opening and closing of the doors. See Figure 1 for more information.
7. Use only UL/ULC listed Type PL or Type L venting for the exhaust system. This heater is designed for use with 3 inch (76 mm) diameter vent pipe. Avoid long runs and too many bends. It may be necessary to increase the size of the vent pipe to 4 inch (102 mm) in diameter if long runs and too many bends are unavoidable. See "Venting System" section for more information.
8. Combustion of wood pellet fuel leaves ash in the heater and venting system. These ashes must be removed from the heater and venting on a regular basis (approximately once a week or more frequently for high ash content fuels). See "Maintenance" section for more information. The entire system must also be cleaned at the start of each heating season. A yearly inspection of the venting is highly recommended.
9. The heater must be turned off and allowed to cool before cleaning. Make sure there are no hot ashes or embers present. Use a brush and scoop to clean. Only use vacuum cleaners specifically designed for use with hot ashes. Place all ashes in a sealed metal

- container with a tight, nonflammable fitting lid.
10. Store all pellet fuel in a sealed metal container at a safe distance (at least 36 inches/ 1 meter) away from the heater. DO NOT place the fuel within the installation clearances of the stove or within the space needed for ash removal and start up.
 11. This heater is POWER VENTED (the vent pipes have a positive pressure during operation). It is IMPERATIVE that all joints in the venting system be SEALED to prevent any leakage of exhaust gases inside the house. All joints must be sealed using high temperature (RTV) silicone sealer. Aluminum tape is not an adequate sealant.
 12. Use of outside combustion air is highly recommended and is mandatory in mobile home installations. Connect the air intake pipe of the heater to the exterior of the building with a noncombustible metal pipe with a minimum diameter of 2 inches (50 mm). Use APR Part Number AK 100. Use of plastic pipe is not permitted.
 13. This appliance is wired and grounded according to the CSA C22.1 code for Canada and the NFPA 70 code for the USA. Also, this heater meets the fuel burning appliance installation codes NFPA 211 in the USA and CSA B365 in Canada.
 14. Do NOT operate the heater with the door open. Make sure the door and any other opening in the stove are closed tightly during operation. Inspect the gaskets of the door and other openings periodically to make sure they are in good condition.
 15. Replace broken or defective components only with parts provided by the manufacturer. Visit **WWW.KOZISTOVES.COM** or contact your local dealer to find out how to purchase replacement parts.
 16. Follow this manual carefully for proper installation. If you are uncertain, call your dealer. Most dealers have qualified and trained installers. We highly recommend the use of their services.
 17. Your **KOZI** stove should be installed, operated and maintained regularly in accordance with this manual. Failure to follow this manual may cause smoke spillage or other potential hazards. Install a smoke and carbon monoxide detector on every floor of your home. Install these detectors near sleeping areas and near the stove. Follow all manufacturers' instructions when operating the smoke and carbon monoxide detectors. Maintain these detectors as stated by the manufacturer.

II. STOVE SPECIFICATIONS

Previa	
*Burn Rate	0.52 - 2.08 lbs/hr
Particulate Emissions	1.02 g/hr
CO Emissions	7.64 g/hr
**Overall Efficiency	76.1%
*Heating Capacity	500 to 2000 sq. ft.
Hopper Capacity (approx.)	60 lbs
*Heat Output Range	8,077 - 27,113 BTU/hr

* Values will vary depending on the quality of pellet fuel being used.

** The Higher Heating Value (HHV) is used to determine the efficiency in accordance with CSA B415.1-09. The HHV is the total amount of heat in a sample of fuel (including the energy in the water vapor that is created during the combustion process). The Lower Heating Value (LHV) is the amount of heat in a sample of fuel minus the energy in the combustion water vapor. Using the HHV will give us a more accurate efficiency rating.

III. INSTALLATION

1. Clearance to Combustibles

i. Installation Clearances

Please refer to the following figures for all clearances to combustibles. Please note that these clearances are for your **KOZI** heater only. Each venting manufacturer/supplier has their individual clearances which must also be respected.

Figure 1. **KOZI** Cast Iron Stove noncombustible floor protector.

All clearances are minimum requirements
See table for actual dimensions

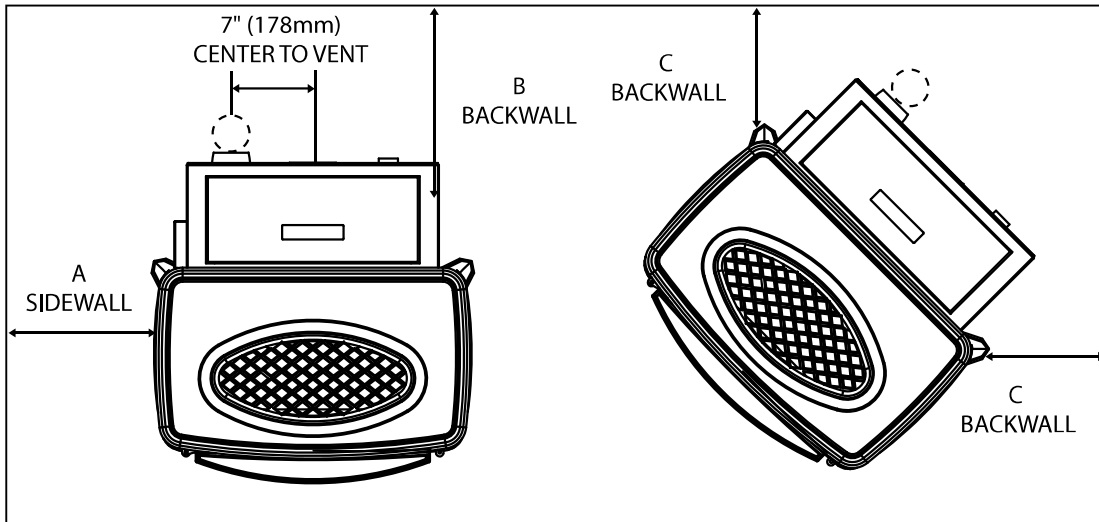

Figure 2. Sidewall clearances

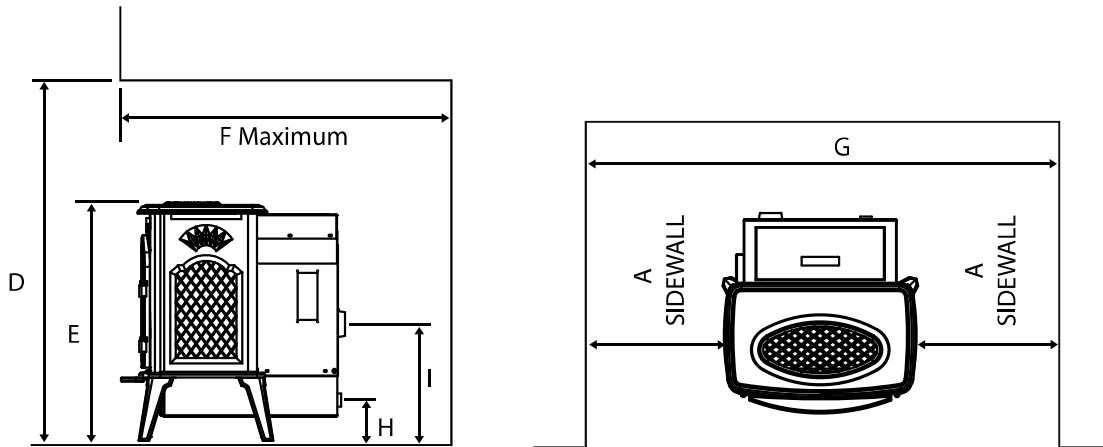

Figure 3. Alcove clearances.

INSTALLATION COMMENT: We recommend sufficient space be provided (minimum 20 inches/500 mm) on each side of the heater to service the equipment area. If this is not possible, a provision must be made to pull the heater out for service.

All dimensions are minimum dimensions unless marked.

Dimension	Description	Previa
A	Unit to side wall or side facing	5" (125 mm)
B	Unit to back wall	1" (25 mm)
C	Corner of unit to wall	1" (25 mm)
D	Alcove height	48" (1220 mm)
E	Overall unit height	30" (760 mm)
F	Alcove depth (Maximum)	30" (760 mm)
G	Alcove width	34" (865 mm)
H	Floor to centerline air intake	5.125" (130 mm)
I	Floor to centerline exhaust	14.5" (370 mm)
J	Unit to mantle	N/A
K	Unit to top facing	N/A

Table 1. Clearance Dimensions

Additional installation information can be found in the “Typical Installation Configurations” section and your venting manufacturer’s/supplier’s literature.

INSTALL VENT AT CLEARANCES SPECIFIED BY THE VENT MANUFACTURER

ii. Other Clearances and Recommendations

1. This heater must be mounted on a noncombustible material, placed underneath the heater and extending a minimum of 6 inches (150 mm) in front and beyond each side of the fuel loading and ash removal openings of the heater.
2. Clearances can ONLY be reduced by means approved by local building fire officials in your area.
3. A safety certification label has been attached to the back of the heater. A sample label is shown here to help you locate this label on your heater. All information on the certification label supersedes an information contained in this manual.



**LISTED ROOM HEATER, PELLETIZED FUEL TYPE
ALSO FOR USE IN MOBILE HOME**
APPAREIL DE CHAUFFAGE RÉPERTORIÉ. À COMBUSTIBLE EN
GRANULES PEUT ÊTRE UTILISÉ DANS UNE MAISON MOBILE.

DO NOT REMOVE THIS LABEL

WH- _____

NE PAS ENLEVER CETTE ÉTIQUETTE

MODEL/MODÈLE: KOZI 100 KSH SERIES PREVIA
TESTED TO: ASTM E1509-04 / UL 1482 - 00 / ULC S627-00 / ULC S628-M93 /
ULC/ORD C1482-M87

THIS PELLET FIRED APPLIANCE HAS BEEN TESTED AND LISTED FOR USE IN MANUFACTURED HOMES IN ACCORDANCE WITH OREGON ADMINISTRATIVE RULES 814-23-900 THROUGH 909.

INPUT RATING: 4.5 LBS/HR
ELECTRICAL RATING: 120 V, 60 HZ, 2 AMPS
INSTALL AND USE ONLY IN ACCORDANCE WITH THE MANUFACTURER'S INSTALLATION AND OPERATION INSTRUCTIONS. SEE LOCAL BUILDING CODE AND MANUFACTURER'S INSTRUCTIONS FOR PRECAUTIONS REQUIRED FOR PASSING VENT COMPONENTS THROUGH A COMBUSTIBLE WALL OR CEILING. CONTACT LOCAL BUILDING OR FIRE OFFICIALS ABOUT RESTRICTIONS AND INSTALLATION INSPECTION IN YOUR AREA. DO NOT CONNECT THIS UNIT TO A CHIMNEY FLUE SERVING ANOTHER APPLIANCE.

MINIMUM CLEARANCES TO COMBUSTIBLE CONSTRUCTION
- **INSTALLED AS A FREESTANDING STOVE**

A. WIDTH OF UNIT	-	25" / 635 mm
B. DEPTH OF UNIT	-	25" / 635 mm
C. SIDEWALL TO UNIT	-	5" / 125 mm
D. BACKWALL TO UNIT	-	1" / 25 mm
E. CORNER TO UNIT	-	1" / 25 mm
MIN. ALCOVE WIDTH	-	34" / 865 mm
MIN. ALCOVE HEIGHT	-	48" / 1220 mm
MAX. ALCOVE DEPTH	-	30" / 760 mm

- INSTALLED AS A FREESTANDING STOVE FOR USE WITH A MASONRY FIREPLACE

F. FLOOR PROTECTOR	-	6" / 150 mm
G. SIDEWALL TO UNIT	-	5" / 125 mm
H. MANTLE TO UNIT	-	13" / 330 mm
I. TOP FACING TO UNIT	-	13" / 330 mm
J. SIDE FACING TO UNIT	-	5" / 125 mm



COMBUSTIBLE FLOOR MUST BE PROTECTED BY A NON-COMBUSTIBLE MATERIAL UNDERNEATH THE UNIT AND EXTENDING TO THE FRONT (D - 6" / 150 mm) AS SHOWN. THE DIMENSIONS FOR THE NON-COMBUSTIBLE FLOOR PROTECTOR SHOULD BE A MINIMUM OF 27" BY 32".

FOR USE WITH PELLETIZED 1/4" OR 5/16" DIA. SOLID WOOD FUELS ONLY. DO NOT BURN COAL. OPERATE ONLY WITH VIEWING DOOR AND ASH REMOVAL DOORS CLOSED. REPLACE GLASS ONLY WITH CERAMIC GLASS. DO NOT ROUTE POWER CORD UNDER THE UNIT. INSPECT AND CLEAN THE EXHAUST VENTING SYSTEM ON A FREQUENT BASIS. COMPONENTS REQUIRED FOR INSTALLATION: 3" / 75 mm DIAMETER LISTED TYPE L OR TYPE PL VENT, OUTSIDE COMBUSTION AIR INLET.

CAUTION: OPERATE THIS UNIT ONLY WITH THE FUEL HOPPER LID CLOSED. FAILURE TO DO SO MAY RESULT IN EMISSION OF PRODUCTS OF COMBUSTION FROM THE HOPPER UNDER CERTAIN CONDITIONS. MAINTAIN HOPPER SEAL IN GOOD CONDITION. DO NOT OVER FILL THE HOPPER.

LIGHTING INSTRUCTIONS

THIS PELLET STOVE IS EQUIPPED WITH A SELF IGNITION SYSTEM. MAKE SURE THAT THE STOVE IS OFF AND THAT THERE IS ADEQUATE FUEL IN THE HOPPER. ENSURE THAT THE BURN POT AND BURN POT STAND ARE CLEAN BEFORE STARTING. CLOSE THE VIEWING DOOR TIGHTLY AND PRESS THE ON/OFF BUTTON. SET THE DAMPER CONTROL AND HEAT SELECT SETTING TO THE DESIRED SETTING.

SHUTDOWN INSTRUCTIONS: PRESS THE ON/OFF BUTTON. THE STOVE WILL GO INTO A COOL DOWN CYCLE AND SHUT DOWN.



CAUTION
HOT WHILE IN OPERATION. DO NOT TOUCH. KEEP CHILDREN, CLOTHING AND FURNITURE AWAY. CONTACT MAY CAUSE SKIN BURNS. SEE NAMEPLATE AND INSTRUCTIONS.
MADE IN CANADA BY:
FABRIQUÉ AU CANADA PAR:

REPORT NO./NO. DE RAPPORT: 6437 (JULY/JUILLET 1992)
ÉPROUVÉ POUR RÉPONDRE AUX NORMES: ASTM E1509-04 / UL 1482-00 / ULC S627-00 / ULC S628-M93 / ULC/ORD C1482-M87

CET APPAREIL DE CHAUFFAGE A ÉTÉ ÉPROUVÉ ET RÉPERTORIÉ POUR UNE UTILISATION DANS LES MAISONS CONSTRUITES CONFORMÉMENT AUX RÈGLES ADMINISTRATIVES DE L'OREGON NOS. 814-23-900 À 909.

PUISSANCE NOMINALE: 4.5 LBS/HR
DONNÉES ÉLECTRIQUES: 120V, 60HZ, 2 AMPS
INSTALLER ET UTILISER L'APPAREIL CONFORMÉMENT AUX INSTRUCTIONS D'INSTALLATION ET DE FONCTIONNEMENT DU FABRICANT. CONSULTER LE CODE LOCAL DU BÂTIMENT ET LES INSTRUCTIONS DU FABRICANT AFIN DE CONNAÎTRE LES PRÉCAUTIONS EXIGÉES POUR L'INSTALLATION DES RACCORDS D'ÉVENT DANS UN MUR OU UN PLAFOND COMBUSTIBLE. COMMUNIQUER AVEC LES AUTORITÉS LOCALES EN MATIÈRE DE BÂTIMENT ET DE LUTTE CONTRE LES INCENDIES POUR CONNAÎTRE LES RESTRICTIONS ET LES NORMES D'INSPECTION DES INSTALLATIONS DANS VOTRE RÉGION. NE PAS RACCORDER À UN TUYAU DE TIRAGE DESSERVANT UN AUTRE APPAREIL.

DÉGAGEMENTS MINIMUMS DES ÉLÉMENTS DE CONSTRUCTION COMBUSTIBLES - INSTALLATION COMME POÊLE NON ENCASTRÉ

A. LARGEUR DE L'APPAREIL	-	25 PO / 635 mm
B. PROFONDEUR DE L'APPAREIL	-	25 PO / 635 mm
C. ENTRE L'APPAREIL ET LE MUR LATÉRAL	-	5 PO / 125 mm
D. ENTRE L'APPAREIL ET LE MUR ARRIÈRE	-	1 PO / 25 mm
E. ENTRE L'APPAREIL ET LES COINS	-	1 PO / 25 mm
LARGEUR MIN. DE L'ALCÔVE	-	34 PO / 865 mm
HAUTEUR MIN. DE L'ALCÔVE	-	48 PO / 1220 mm
PROFONDEUR MAX. DE L'ALCÔVE	-	30 PO / 760 mm

-INSTALLATION COMME POÊLE NON ENCASTRÉ À L'INTÉRIEUR D'UNE CHEMINÉE DE MAÇONNERIE

F. RECOUVREMENT DU PLANCHER	-	6 PO / 150 mm
G. ENTRE L'APPAREIL ET LE MUR LATÉRAL	-	5 PO / 125 mm
H. ENTRE L'APPAREIL ET LE MANTEAU DE LA CHEMINÉE	-	13 PO / 330 mm
I. ENTRE L'APPAREIL ET LE PAREMENT SUPÉRIEUR	-	13 PO / 330 mm
J. ENTRE L'APPAREIL ET LE PAREMENT LATÉRAL	-	5 PO / 125 mm

LE PLANCHER COMBUSTIBLE DOIT ÊTRE RECOUVERT D'UN MATÉRIAU NON COMBUSTIBLE SOUS L'APPAREIL ET DEVANT L'APPAREIL (DISTANCE D-6 PO / 150 mm) TEL QU'ILLUSTRE. LE MATÉRIAU DOIT ÊTRE AU MOINS 27 PO X 32 PO.

N'UTILISER QUE DES GRANULES DE COMBUSTIBLE SOLIDE AU BOIS DE 1/4 PO OU DE 5/16 PO DE DIAMÈTRE. NE PAS BRÛLER DE CHARBON. FERMER LES PORTES D'OBSERVATION ET D'ÉVACUATION DES CENDRES AVANT DE FAIRE FONCTIONNER L'APPAREIL. NE REMPLACER LE VERRE QU'AVEC DU VERRE CERAMIQUE. NE PAS METTRE LES FILS ÉLECTRIQUES SOUS L'APPAREIL. INSPECTER ET NETTOYER LES ÉVENS SOUVENTS. ÉLÉMENTS REQUIS POUR L'INSTALLATION ÉVANT RÉPERTORIÉ DE TYPE L OU PL DE 3 PO / 75 mm DE DIAMÈTRE. PRISE D'AIR DE COMBUSTION EXTÉRIEURE.

ATTENTION: FAIRE FONCTIONNER CETTE UNITÉ UNIQUEMENT SI LE COUVERCLE DE LA TRÉMIE EST FERMÉ. DANS CERTAINES CONDITIONS, LE NON-RESPECT DE CETTE CONSIGNE PEUT ENTRAÎNER DES ÉMISSIONS DE PRODUITS DE LA COMBUSTION. MAINTENIR LE JOINT DE TRÉMIE EN BON ÉTAT. NE PAS FAIRE DÉBORDER LA TRÉMIE.

INSTRUCTIONS DE MISE À FEU:

CE POÊLE À GRANULES EST ÉQUIPÉ D'UN SYSTÈME D'AUTO-ALLUMAGE. S'ASSURER QUE LE POÊLE EST ÉTEINT ET QU'IL Y A SUFFISAMMENT DE COMBUSTIBLE DANS LA TRÉMIE. S'ASSURER QUE LA CHAMBRE DE COMBUSTION ET SON SUPPORT SONT PROPRES AVANT DE COMMENCER. BIEN FERMER LA PORTE D'OBSERVATION ET APPUYER SUR LE BOUTON MARCHÉ/ARRÊT. PLACER LES COMMANDES DE REGISTRE ET DE SÉLECTION DE CHALEUR SUR LES RÉGLAGES DÉSIRÉS.

POUR FERMER L'APPAREIL: APPUYER SUR LE BOUTON MARCHÉ/ARRÊT. LE POÊLE ENTAMERA UN CYCLE DE REFROIDISSEMENT ET S'ÉTEINDRA.

MISE EN GARDE

L'APPAREIL DEVIENT CHAUD LORSQU'IL FONCTIONNE. NE PAS TOUCHER. ÉLOIGNER LES ENFANTS, LES VÊTEMENTS ET LES MEUBLES DE L'APPAREIL. TOUT CONTACT PEUT ENTRAÎNER DES BRÛLURES. CONSULTER LA PLAQUE D'IDENTIFICATION ET LES INSTRUCTIONS.

Figure 5. Certification label.

2. Electrical Requirements

1. This heater is an electrical appliance. The North American versions of this appliance require 120 Volts, 60 Cycles and 3 Amps of electrical power. The European versions of this appliance require 230 Volts, 50 Cycles and 2 Amps of electrical power. All heaters will require an additional 300 Watts of electrical power during the start up sequence (due to the electric igniter).
2. The heater comes with a 5 ft (1.5 meter) long, grounded, electrical cord suitable to plug into any standard residential electrical outlet.

The electrical outlet must be grounded.

3. When installed in a mobile home, the heater must be grounded to the steel chassis of the home (unless this is not required by local code).

3. **Fuel Requirements**

i. **Physical Properties**

Your heater is very sensitive to fuel quality. Every effort should be made to use only the best pellet fuel available in your area. This heater is designed for premium grade, 1/4 inch (6.35 mm) or 5/16 inch (7.94 mm) diameter wood pellets only. The following should assist you in selecting the proper fuel.

<u>Good Fuel</u>	<u>Bad Fuel</u>
Made from hard or soft wood	Moist or wet
Dry	Lots of fines or sawdust
Clean	Longer than 1" in length
1/4" - 5/16" in diameter	Contains binders (helps glue the fuel together)
1" or less in length	High ash content (greater than 1%)
Low ash content (less than 1%)	Not made of wood

Burning any fuel other than wood pellets as described as above will void your heater's warranty and may void any insurance.

If you find your fuel has too much fines and sawdust, the fuel may be screened before use. DO NOT USE WET PELLETS under any circumstances. Longer fuel may cause bridging of the auger and result in erratic feeding or jamming. Fines, binders, ash, moisture will all cause your heater to plug up and not burn efficiently. "Poor" fuels require more frequent cleaning; the ash tray must be emptied and the burn pot must be cleaned on a weekly/possibly daily basis. Please refer to the "Maintenance" section for further instructions on cleaning your heater.

This heater is designed to burn premium grade wood pellets. Higher efficiencies and lower emissions will generally result when burning premium grade wood pellets as compared to fuels with higher ash and moisture contents.

ii. **Fuel Storage**

All pellet fuel should be stored in a clean, dry place and at a safe distance (at least 36 inches /1 meter) away from the heater. DO NOT place the fuel within the installation clearances of the heater or within the space needed for ash removal or starting of the heater.

WARNING: Do not burn:

- Garbage
- Lawn clippings or yard waste
- Materials containing rubber, including tires
- Materials containing plastic
- Waste petroleum products, paints or paint thinners or asphalt products
- Materials containing asbestos
- Construction or demolition debris
- Railroad ties or pressure-treated wood
- Manure or animal remains
- Paper products, cardboard, plywood or particleboard

Burning these materials may result in release of toxic fumes or render the heater ineffective and cause smoke.

4. Location of the Heater

Before proceeding with the installation, the following sections should be reviewed:

Section 4. Location of the Heater

Section 5: Typical Installation Configurations

Section 6: Venting System

When selecting a location for your new heater consider the following:

- | | |
|--|---|
| a. Clearance to combustibles. | e. Power within 5 feet (1.5 meter). |
| b. Sufficient room to service the unit. | f. Access for exhaust venting. |
| c. Access for outside combustion air. | g. EVL not exceeding 25 feet |
| d. NOT approved for bedroom installations. | (7.6 meter). See “Exhaust Vent Requirements” section) |

Locate your stove in the main living space where the majority of the heat is needed to get the best efficiency out of your stove. For example, installing a stove in a basement when the heat is needed on the main floor is not the best location for your stove. The heat being produced in the basement may rise to the upper floors, but is usually too slow and provides limited comfort on the upper floors. In order to keep the upper floors heated comfortably, the basement would be overheated, thus more pellet fuel is used, reducing the efficiency of the stove. Locate the stove in an open area that has very little restrictions on air movement (i.e. not near walls, doors, etc.). Installing the stove in a confined space will reduce the amount of heat in other areas and will reduce your stove’s efficiency. This stove is designed for indoor use only. Installing the stove outdoors will

reduce the efficiency of the stove significantly, increase fuel consumption and will make it difficult to heat the desired area comfortably.

5. Typical Installation Configurations

The following describe some typical installations. Variations of these are possible. Common sense, safety and compliance with local codes must be respected in any variation.

Wood smoke contains gases and tiny particles that when inhaled or breathed can have serious health effects. In the cold, stagnant air prevents the wood smoke from rising and can create unhealthy air quality or can become a nuisance for neighbors. This smoke can seep into surrounding homes even with doors and windows fully closed. Please locate your heater and install the venting with this in mind.

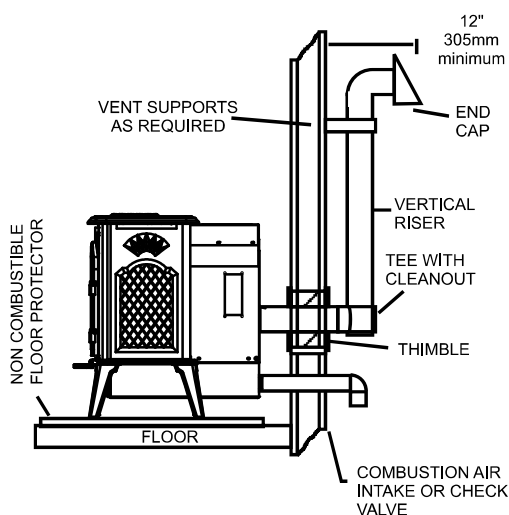

Figure 6. Free standing through the wall and up installation.

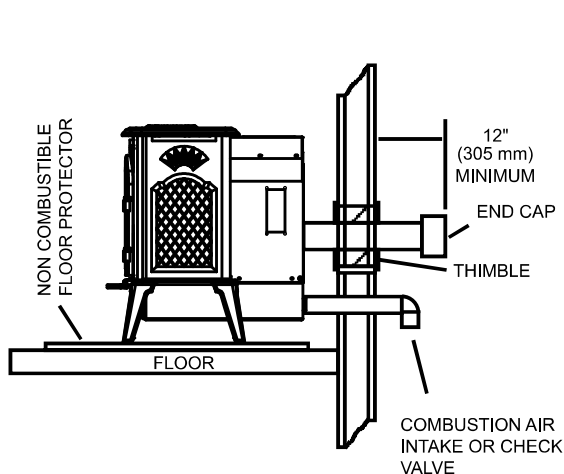

Figure 7. Free standing through the wall installation

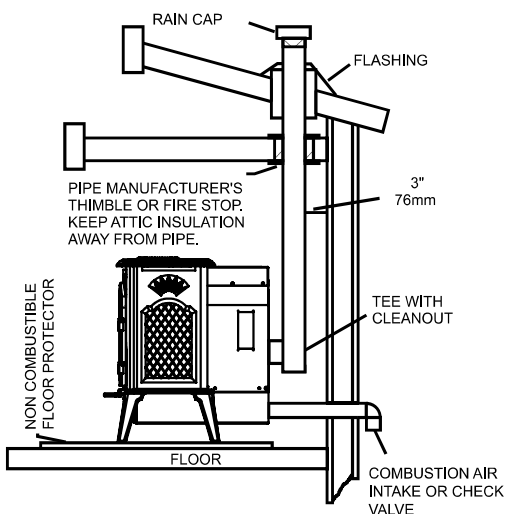

Figure 8. Free standing through the roof installation.

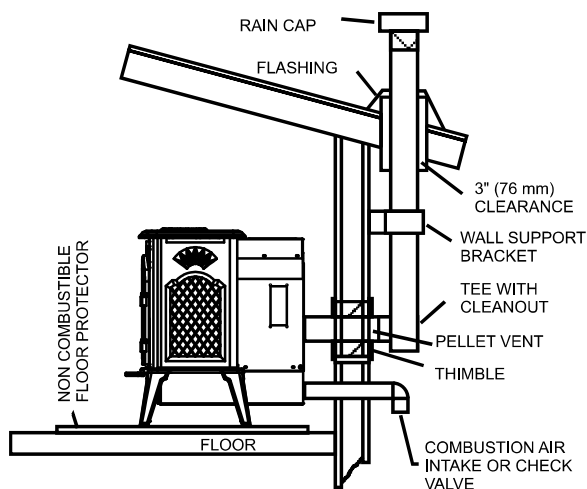

Figure 9. Free standing through the wall and roof installation.

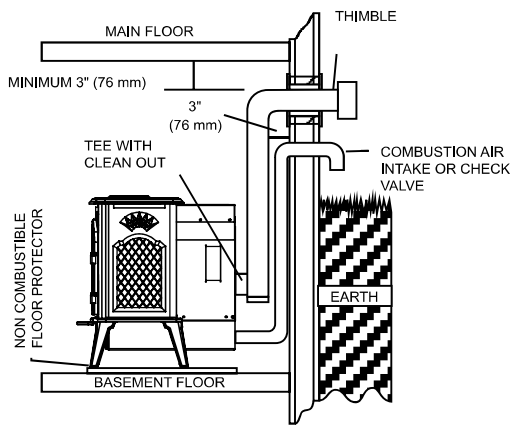

Figure 10. Free standing basement installation.

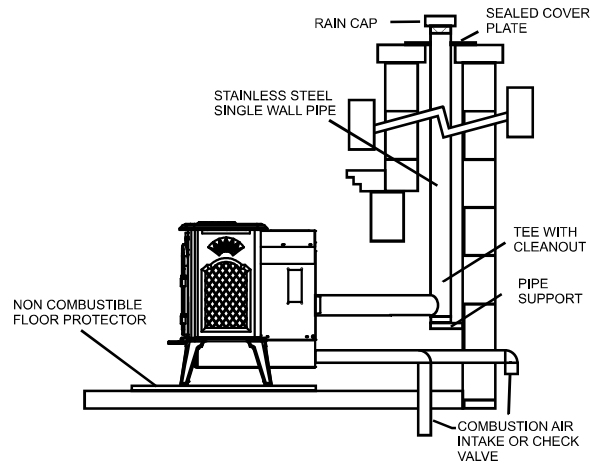

Figure 11. Free standing through a masonry chimney installation.

6. Venting System

i. Exhaust Vent Pipe Requirements

Your **KOZI** pellet heater works under negative pressure (vacuum). The exhaust fan of your stove pulls air from the air intake, through the stove and pushes it out the venting. As this air passes through the burn pot, it is used to burn the pellets. Proper vent pipe sizing is very important to the proper operation of your stove. A proper size UL/ULC listed Type PL or L venting should be used to provide the least resistance for movement of combustion air.

Your **KOZI** pellet heater is certified for 3 or 4 inch diameter exhaust venting. 3 inch venting is normally sufficient for most direct vent installations. Installations with several elbows, long horizontal and/or vertical runs may add too much resistance to airflow and may create burn problems. The use of 4 inch venting in these types of installations will reduce the possibility of burn problems. A simple technique called “EQUIVALENT VENT LENGTH” (EVL) can be used to determine whether 3 inch or 4 inch diameter vent pipe should be used.

To calculate EVL use the following formula:

for each 90° Elbow or T-Fitting	= add 5 EVL
for each 45° Elbow	= add 3 EVL
for each Horizontal run of venting	= add 1 EVL/foot of horizontal run
for each Vertical run of venting	= add 1/2 EVL/foot of vertical run

CAUTION: EVL CANNOT EXCEED 25. Installations using an EVL exceeding 25 are not permitted.

YOU MUST USE APPROPRIATE 4" DIAMETER VENTING IF:

The EVL is 7 or more AND you are at or above an altitude of 3000 ft.

OR

The EVL is 15 or more.

If in doubt, use 4" diameter venting. This will reduce the possibility of future burn problems.

DO NOT USE MAKESHIFT MATERIALS OR MAKE
COMPROMISES IN THE INSTALLATION. IT IS A FIRE HAZARD.

DO NOT INSTALL A FLUE DAMPER IN THE EXHAUST
VENTING SYSTEM OF THE HEATER

DO NOT CONNECT THIS HEATER TO A CHIMNEY FLUE
SERVING ANOTHER APPLIANCE

The vent pipes are on the exhaust side of the exhaust fan and are under pressure. Care must be taken to ensure that all the joints are completely sealed to prevent any leakage of exhaust fumes and smoke into the house. If you smell smoke, the venting has not been properly sealed. Use only high temperature RTV silicone for sealing. Aluminum tape is not considered an adequate sealant. At least 3 screws are needed for securing all vent pipe joints.

The venting of this heater is not allowed to pass through any closet, concealed spaces, floors, ceilings or attic spaces. If the venting must go through a wall or combustible partition, the installation must conform to the Installation Code for Solid Fuel Burning Appliance and Equipment CAN/CSA-B365. For more detailed venting information, please refer to your venting manufacturer's instructions.

ii. Exhaust Vent Pipe Requirements

1. It is highly recommended that the venting include a minimum of 3 foot vertical rise before termination. This will help prevent any odor of smoke in the house during a power failure.
2. The exhaust vent must terminate into an open space. Under no circumstances is the vent allowed to terminate into closed or semi-closed spaces. Venting into a garage, under a sun deck, porch or any other space where the concentration of fumes may occur is prohibited.
3. The exhaust vent must be at least:

- * 4 feet (1.2 meter) below
- * 4 feet (1.2 meter) horizontally from
- * 1 foot (0.3 meter) above

any opening in the building such as doors, windows, ventilation air intakes, etc. (NOTE: You can reduce the clearance to 18 inches below or 18 inches horizontally from any opening ONLY if an air intake kit is installed).

4. The exhaust vent opening must be a minimum of:
 - * 12 inches (0.3 meters) from the ground
 - * 24 inches (0.61 meters) from any combustible surface (i.e. fence, plant, etc.)
 - * 7 feet (2.1 meters) from any public walkway
5. The exhaust air is EXTREMELY HOT. Caution must be taken to avoid contact with children, people, plants, animals or any other object that may be affected by heat. It is recommended to use a vertical pipe to discharge the hot air at a safe elevation.
6. Vertical installations must have an approved vertical vent cap and horizontal installations must have an approved horizontal vent cap. Areas where severe wind conditions exist and vent caps are exposed to unprotected, open areas, additional protection (especially in horizontal installations) must be provided.

INSTALL ALL VENTING AT CLEARANCES SPECIFIED
BY THE VENT MANUFACTURER

iii. Combustion Air Intake Requirements

There are 2 methods of supplying the heater with combustion air. They are as follows:

1. Room Air: Conventional homes may use room air for combustion. Where room air is used, it is recommended that the exhaust pipe incorporates a minimum 3 foot vertical section immediately adjoining the heater. It is highly recommended that the total exhaust vertical rise be longer than the total horizontal run and that the majority of the vertical rise be as close to the heater as possible.
2. Outside Air: All installations can be connected to the exterior of the building using a noncombustible metal pipe, with a minimum 2 inch (50 mm) internal diameter or by using APR Part No: AK100 (Air Intake Kit). A larger diameter air intake pipe may be required if the length of intake exceeds 3 feet (1 meter) or has several bends. Use of plastic pipes are not permitted

In some installations, outdoor combustion air may be needed to ensure proper performance. If your heater burns poorly, experiences roll-out or back-drafts, outside combustion air may be required.

The following restrictions apply to any and all installations:

1. Use of plastic pipes is not permitted under any circumstance.
2. The combustion air intake must terminate into a vented space (i.e. outside, vented attic, vented crawl space, etc.). This heater cannot draw air from a closed space such as a closed garage, airtight crawl space or any other sealed room.
3. The elevation of the combustion air intake must be below the exhaust vent. An elbow may be used to lower the air intake point below that of the exhaust vent.
4. Excessive lengths and elbows on the air intake pipe will cause airflow restrictions. A minimum of 2 inches (50 mm) or larger venting should be used for lengths exceeding 3 feet (1 meter). Increase venting size as needed.
5. When installing a **KOZI** Previa in a garage/workshop, the combustion air must be taken from the outside or else the unit must be elevated a minimum of 15 inches above floor level if inside combustion air is desired.

7. Mobile Home Additional Installation Requirements

i. Typical Mobile Home Installation Configuration

The following figures describe some typical installations for mobile homes. Variations of these are possible. Common sense, safety and compliance with local building codes must be respected in any variation.

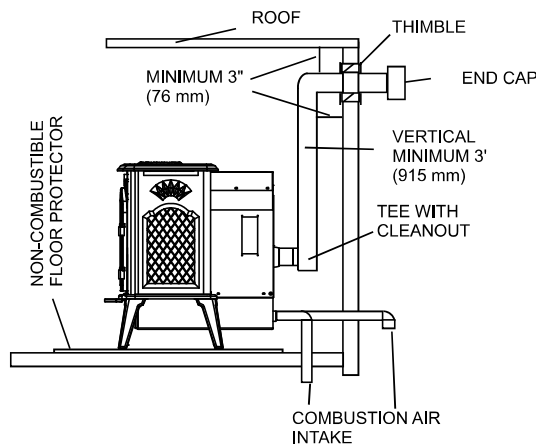

Figure 12. Mobile home installation through wall; interior rise.

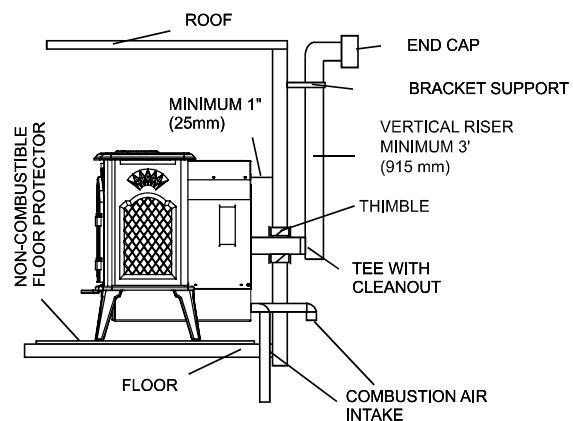

Figure 13. Mobile home installation through wall; exterior rise.

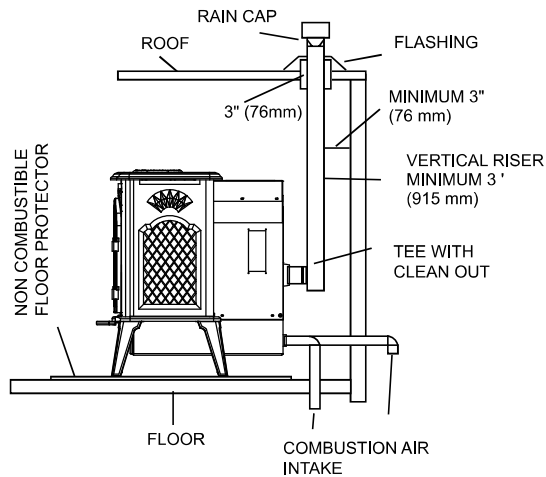

Figure 14. Mobile home installation through roof.

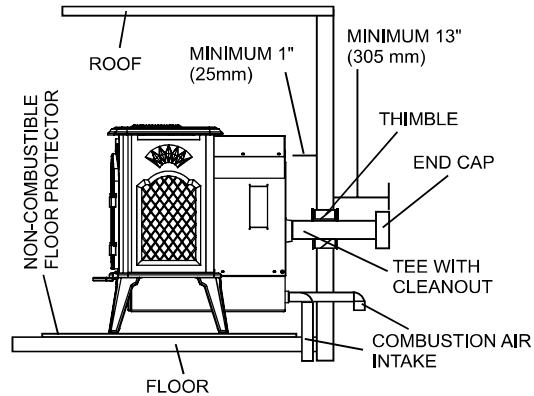

Figure 15. Mobile home installation through wall.

ii. Recommendations for Mobile Home Installation

1. Make sure there is an effective vapor barrier where the venting penetrates to the outside of the mobile home. Seal all openings in the vapor barrier as required.
2. Make sure the mobile home has adequate ventilation. Your stove is a solid fuel burning appliance. As such, there is a possibility of smoke entering the room. By making sure the mobile home is adequately vented, you reduce the chances of smoke remaining in the mobile home.
3. Make sure the venting is properly installed and sealed. Leaking vent pipes may set off smoke detectors in the mobile home. Also, some fuels may produce carbon monoxide which, in large amounts, can be fatal. Make sure the venting is installed properly to prevent leakage of carbon monoxide into the mobile home.
4. If parts become damaged or need to be replaced, please contact your local dealer or visit WWW.KOZISTOVES.COM. Do NOT replace parts with any other parts not specified by your local dealer or manufacturer.

iii. Mobile Home Combustion Air Intake Requirements

All mobile home installations **MUST** use combustion air from the outside. This heater must be connected to the exterior of the mobile home using a noncombustible metal pipe with a minimum 2 inch (50 mm) diameter. APR Industries Ltd. Part No AK100 (Air Intake Kit) can be used for this purpose. Use of plastic pipes are not permitted. Please read the “Combustion Air Intake Requirements” section for more information.

iv. Exhaust Vent Requirements

Venting a **KOZI** pellet burner for a mobile home is similar to that of a conventional home. Please refer to the “Typical Mobile Home Installation Configuration” section for typical venting configurations in the “Venting System” for the vent termination and other requirements. It is highly recommended that a 3 foot minimum of vertical venting be used (as shown in Figure 12 and Figure 13). This will reduce the chance of smoke spillage into the mobile home in case of a power failure.

v. Other Mobile Home Installation Requirements

1. The heater must be securely anchored to the floor of the mobile home. There are 4 holes located on the legs of the stove. Use lag bolts (not supplied) in these holes to anchor the stove to the floor of the mobile home.
2. There must be a noncombustible floor protector placed underneath the heater and extending a minimum of 6 inches (150 mm) in front of the heater (see “Clearance to Combustibles” section for more information).
3. This heater can not be installed in any sleeping room of the mobile home.
4. The heater must be grounded to the steel chassis of the mobile home (unless this is not required by local code).
5. The installation must be in accordance with the Manufactured Home and Safety Standard (HUD), CFR 3280, Part 24.

WARNING: DO NOT INSTALL IN A BEDROOM OF A MOBILE HOME.

CAUTION: THE STRUCTURAL INTEGRITY OF THE FLOOR, WALL AND ROOF OF THE MOBILE HOME MUST BE MAINTAINED.

IV. OPERATION

1. General Overview

The first step in understanding your new **KOZI** heater is to familiarize yourself with its operation. Your heater has 3 main systems: Feed, Combustion and Circulation. These 3 systems work together to produce enough heat for your room. The feed system uses an auger to “feed” the pellet fuel into the burn pot. The combustion system provides the air for the fuel to burn and pushes the “smoke” outside through the vent pipes. The circulation system takes cold air from the room and pushes it through the heat exchanger where it gets hot and then flows back into the room as hot air. These 3 main systems are all controlled

by the *MX2*TM control system (see Figure 16). The *MX2*TM control system will be described in more detail later.

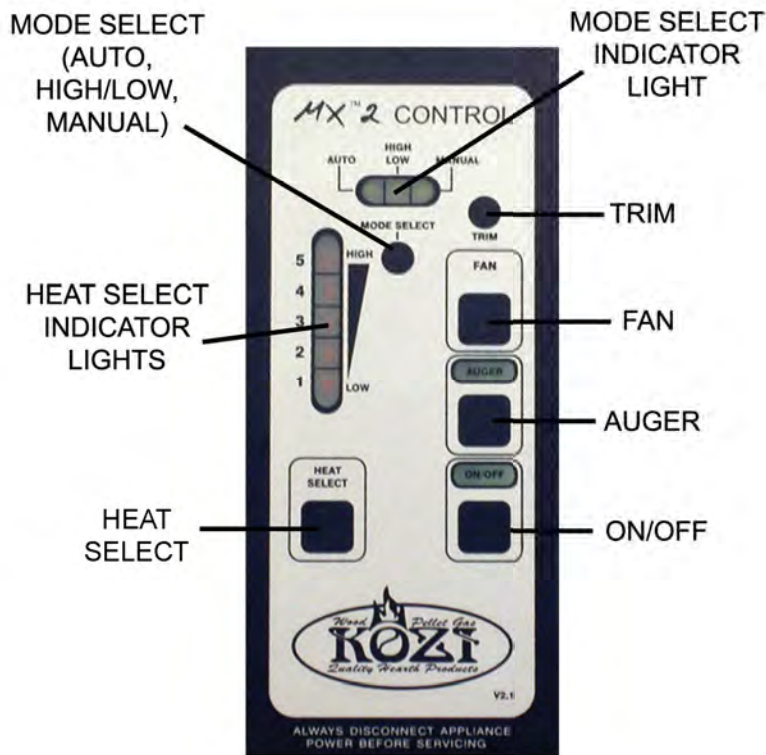

Figure 16. *MX2*TM control board.

2. Safety Features

1. Pressure Switch: This safety device is used to turn the feed off if pressure is lost in the stove.

Please note that if your door is open or your ash gates/tray are not properly sealed, your pellet heater will not feed.

2. Circulation Fan Override: If your pellet heater begins to overheat, this safety device switches the circulation fan to the highest possible setting to try to cool your heater down to a safe temperature.
3. High Limit/Manual Reset Thermal Disk: If the circulation fan override fails to cool the heater down fast enough, this thermal disk will turn the feed off. This safety device guards against your heater from overheating. If this thermal disk trips, the right side panel will need to be opened and the thermal disk reset. See the “Maintenance” and “Troubleshooting” sections for more information.
4. Hopper Lid Switch: This safety device stops the auger from

turning when the hopper lid is opened preventing any bodily harm.

3. Electric Igniter

The **KOZI** Previa Cast Iron pellet stove is factory equipped with an electric igniter. The electric igniter is a convenient way of lighting the fire in your heater without the use of lighter gels or starter fuels.

4. **MX2™ Controls**

i. Basic Description

The **MX2™** control is a digital control system that uses a computer to control the operation of your heater. You should be familiar with all of the buttons on this control before using your heater. Each button and their function are described here.

ii. “AUTO, HIGH/LOW, MANUAL” Modes

Your pellet heater is capable of operating in 3 modes: “AUTO”, “HIGH/LOW” and “MANUAL”. Figure 17 will help you determine which mode is suitable for use in your home. More information on each of the modes is provided later.

Mode Selection Guide			
Switch Position	Igniter Required	Thermostat Required	Description
AUTO*	Yes	Yes	Turns Heater ON and OFF based on wall thermostat, remote control, wall switch or other switching device.
HIGH/LOW	Optional	Yes	Switches heater from user setting to factory LOW setting based on wall thermostat, remote control, wall switch or other switching device.
MANUAL	Optional	No	Relies on a person to press the ON/OFF button located on the control panel. Will automatically light if equipped with electric igniter.
* CAUTION: May result in shortened igniter life. See complete mode description.			

Figure 17. Mode Selection.

- a. “AUTO” Mode: With the switch in this position, your heater will turn itself on and off based on an externally wired switch (millivolt systems only). The most common use of this mode is with a wall thermostat. When wired to a wall thermostat, the heater will automatically light itself when the room temperature falls below the thermostat setting and will automatically turn itself off when the temperature reaches the thermostat setting. This mode can also be used with any millivolt rated wall switch or remote controls.

Consult your local dealer or visit WWW.KOZISTOVES.COM for more information on available options.

Please note that the “AUTO” mode, when used in conjunction with any millivolt rated switching device, may result in “reduced” igniter life. Always use your stove on the lowest possible heat setting when in this mode. This will help reduce the number of ignition cycles and will help prevent premature igniter failure.

- b. “HIGH/LOW” Mode: With the switch in this position, your heater will alternate from a factory preset low to the setting you have chosen with the “HEAT SELECT” button (see “HEAT SELECT: Button” section for more information). This mode is almost exclusively used with a millivolt switching device and is highly recommended since it can create substantial fuel savings.
- c. “MANUAL” Mode: When used in this mode, your stove is controlled from the control panel only. When the heater is in the “MANUAL” mode, the heater will not respond to any external switching device (i.e. wall thermostat, remote control, etc.). To start the stove you must press the ON/OFF button. The stove will go through a start up cycle and once it has warmed up sufficiently, the stove will operate at the heat setting chosen. The stove will continue to operate until it is not needed. To shut the stove down press the ON/OFF button again and the stove will go into a shut down sequence. Once the stove is cold, it will automatically shut the fan motors off.

iii. “ON/OFF” Button

This button allows you to turn the stove on and off manually. Once pressed, the stove will go through a start-up sequence and the ON/OFF light will begin to blink. During this time, the feed rate is preset. Once the “HEAT SELECT” light comes on, select the setting you want the stove to operate at. Once the stove is warm enough, the “ON/OFF” light will stay on solid and the stove will operate at the “HEAT SELECT” setting that you have chosen.

iv. “HEAT SELECT” Button & Bar Graph

There are 5 possible heat settings for your heater. Each setting is indicated in the bar graph; 1 being the lowest and 5 being the highest setting. Pressing the “HEAT SELECT” button will change the heat setting as indicated in the bar graph. Each time the button is pressed, your heater will go to the next higher heat level (from 1 to 2, 2 to 3, etc.). Once the heat level reaches the highest setting (5) and the “HEAT SELECT” button is pressed again, the heat level will return to the low setting (1).

Please note that during the start-up period, the “HEAT SELECT” button can be set. However, the heater will not operate at the desired setting until it has warmed up properly. Also, your heater will always remember which heat setting was used last and return to that setting next time the stove is turned on (power failures will result in this setting being lost).

v. “AUGER” Button

Your heater uses an auger system to feed fuel into the burn pot. When the auger system is working the “AUGER” light will blink. The higher the “HEAT SELECT” setting, the faster the “AUGER” light will blink. The lower the “HEAT SELECT” setting, the slower the “AUGER” light will blink.

Holding the “AUGER” button down will run the auger system continuously. *This button should only be used to fill the auger with fuel when it is empty.* Using this button during normal operation will cause too much fuel to fall into the burn pot and may result in damage to the heater or an unsafe situation.

vi. “FAN” Button

During normal operation of your heater, the circulation fan (blows the hot air into the room) will operate at a preset speed based on the heat setting. The speed can be changed by changing the heat setting or by pressing the “FAN” button. The “FAN” button is used to override the factory setting and run the circulation fan on the highest setting. Pressing the “FAN” button again will slow the fan down. There are 5 settings in total for the fan speed. Once the fan is in the lowest setting, pressing the “FAN” button again will bring the fan back up to the highest setting. If you want to operate the fan at the original preset setting, first press the “HEAT SELECT” button to change the setting. Now, press the “HEAT SELECT” button until you bring it back to the setting you want to operate the stove at.

vii. “TRIM” Button

This button is used to compensate for fuel variations at the lowest heat level only. With the heater at the lowest heat level (1) pressing this button once will increase the feed rate to slightly above the normal low setting. At this “TRIM” setting, the (1) and (5) lights will be on. Pressing the “TRIM” button again will cause the feed rate to decrease slightly below the normal low setting. At this “TRIM” setting, the (1) and (4) lights will be on. Pressing the “TRIM” button again will return the feed rate to the normal low setting. At this “TRIM” setting, only the (1) light will be on.

viii. Wall Thermostat, Wall Switch or Other Switching Device

The *MX2*TM control is capable of using a millivolt rated external switch (i.e. wall thermostat, remote control, etc.) to turn the stove on and off. Any millivolt rated switching device can be used with this control. The switch/thermostat must be wired to the terminals as shown in Figure 18.

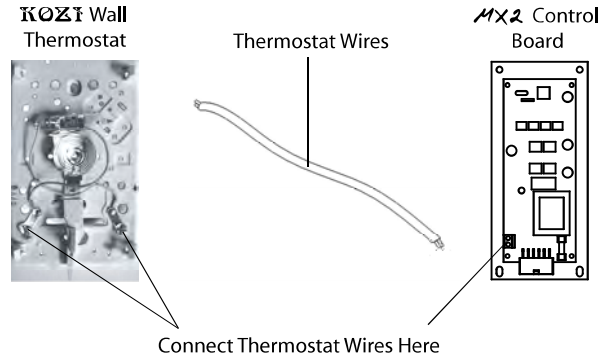

Figure 18. Wall thermostat terminals.

TO PREVENT INJURY OR DAMAGE TO THE HEATER, ALWAYS UNPLUG THE HEATER FROM THE POWER OUTLET BEFORE SERVICING.

ix. Damper Control

The damper control rod is located on the left side of the heater (as you are looking at the stove from the front). This rod controls the amount of air passing through the burn pot. By pushing the control rod in, you reduce the amount of air passing through the burn pot. Conversely, by pulling the rod out, you will increase the amount of air passing through the burn pot. Once set, you should not need to adjust the damper. The *MX2*TM control will automatically change the exhaust fan speed to adjust the amount of combustion air needed for each heat setting.

Each heat setting will have a corresponding damper opening. Figure 19 lists the heat setting and corresponding damper opening:

PREVIA CAST IRON STOVE	
HEAT SETTING	DAMPER OPENING FROM FULLY CLOSED POSITION
1	0.25" (6.35 mm)
2	0.5" (12.7 mm)
3	1" (25.4 mm)
4	1.5" (38.1 mm)
5	FULLY OPEN

Figure 19. Heat and damper settings.

WARNING: This wood heater has a manufacturer-set minimum low burn rate that must not be altered. It is against federal regulations to alter this setting or otherwise operate this wood heater in a manner inconsistent with operating instructions in this manual.

x. Starting Your Heater for the First Time

Read the following instructions completely before attempting to light your heater for the first time. This method applies to all the modes of operation (“AUTO”, “HIGH/LOW”, “MANUAL”). For the “AUTO” mode, use a thermostat or other switching device in lieu of the “ON/OFF” button.

Once your heater is properly installed, complete the following steps to light it for the first time or whenever your heater runs out of fuel:

- a. Fill the hopper with pellet fuel. At this time the auger tube is empty. It needs to be filled before the heater can be operated properly.
- b. Press the “ON/OFF” button: The “ON/OFF” and “AUGER” lights should begin to blink. The motors should also begin to turn.
- c. Adjust the “HEAT SELECT” light to the desired level.
- d. Adjust the damper opening according to the heat setting chosen (see Figure 19).
- e. Press and hold the “AUGER” button; the “AUGER” light should stay lit until the button is depressed.
- f. Continue to hold the “AUGER” button until the fuel begins to drop into the burn pot (located inside the burn chamber, see “Stove Cross Section” diagram for exact location). This may take several minutes. If the heater turns OFF before pellets begin to drop, repeat steps b,c,d and e.
- g. Release the “AUGER” button once the pellet fuel begins to drop.
- h. Monitor the burn pot. A flame should appear within 5-8 minutes. Allow the flame to stabilize. **IN THE EVENT YOUR HEATER SHUTS OFF BEFORE THE FLAME IS STABLE**, or if a flame does not appear, press the “ON/OFF” button once again to get the stove started.
- i. Refer to the “Adjusting Your Heater” section for more information on operating your heater properly.

xi. Starting/Lighting your Heater

To start your heater, complete the following steps:

- a. Ensure there is adequate amount of fuel in the hopper and that all

- ash gates, ash tray and door are closed.
- b. Press the “ON/OFF” button. The following should happen:
 1. The exhaust fan will start.
 2. The circulation fan will remain off.
 3. The feed system will start. The “AUGER” and “ON/OFF” lights will begin to blink.
 4. The igniter will start and you should see a flame within 5-8 minutes.
 - c. Adjust the “HEAT SELECT” setting to the desired level.
 - d. Adjust the damper opening according to the heat setting chosen (see Figure 19).
 - e. Allow the flame to stabilize for 15-30 minutes.
 - f. If the heater shuts off during the start up cycle and there is still a flame, press the “ON/OFF” button again to start another start up sequence.

NEVER USE GASOLINE, GASOLINE-TYPE LANTERN FUEL, KEROSENE, CHARCOAL LIGHTER FLUID OR SIMILAR LIQUIDS TO START OR “FRESHEN UP” A FIRE IN THIS HEATER. KEEP ALL SUCH LIQUIDS WELL AWAY FROM THE HEATER WHILE IT IS IN USE.

WARNING: Make sure the amount of fuel in the burn pot does not exceed the height of the burn pot at any point during operation. This can cause severe damage to your heater.

DO NOT BURN GARBAGE OR FLAMMABLE FLUIDS SUCH AS GASOLINE, NAPHTHA OR ENGINE OIL.

HOT WHILE IN OPERATION. KEEP CHILDREN, CLOTHING AND FURNITURE AWAY. CONTACT MAY CAUSE SKIN BURNS.

DO NOT OVER-FIRE. IF THE HEATER OR VENTING BEGIN TO TURN RED OR GLOW, THE HEATER IS OVER-FIRING. OVER-FIRING YOUR HEATER WILL VOID YOUR WARRANTY.

xii. Stopping Your Heater

To stop your heater, simply press the “ON/OFF” button (for “AUTO” mode, switch the thermostat or other switching device to “OFF”). This will cause the feed system to stop (the “AUGER” light will stop blinking) and the flame should die out within 5 minutes. The exhaust fan and circulation fan will continue to run until your heater is cold (approximately 30 minutes). DO NOT turn OFF

electrical power to stop the heater, as this will result in your heater overheating and may damage the heater.

xiii. Adjusting Your Heater

The heater will not work properly if the ash door or the glass door are not properly closed OR if the wrong size of venting is used. It is equally important that you use good quality, wood pellet fuel. Some fuels have a tendency to leave ash and clinker deposits in the bottom of the burn pot. Poor fuel will create a poor burn, excessive ash and will plug the burn pot. Refer to the “Fuel Requirements” section for more information on fuel quality.

To increase the heat output of your heater, simply press the “HEAT SELECT” button and adjust the damper accordingly (see Figure 19). In a few minutes the flame size will increase.

Having the proper draft will allow your stove to burn clean and efficiently. When the stove is burning correctly, you should see minimal to no visible smoke from your exhaust venting. When smoke is present, there is a chance of high CO emissions being produced by the stove. When there is minimal or no smoke visible, the stove will produce low CO emissions. If you see continuous smoke, you may have inadequate or excess draft so adjust the draft accordingly.

In certain situations (i.e. venting configuration, poor pellet, location of the stove, etc.) you may find that you have inadequate or excessive draft. If the pellets begin to pile up in your burn pot and the flame changes appearance (i.e. larger, dark in color and lazy), you have inadequate draft. Open the damper slightly (approximately 1/8” increments) and allow 10-15 minutes for the flame to stabilize. Repeat if necessary. If the pellets seem to burn too quickly and the flame changes appearance (i.e. smaller, really bright in color and very active), you have excessive draft. Close the damper slightly (approximately 1/8” increments) and allow 10-15 minutes for the flame to stabilize. Repeat if necessary. You will notice that a proper flame will look bright in color, active and the pellets do not pile up or burn too quick.

V. MAINTENANCE & CLEANING

Formation and Removal of Soot and Flyash - During normal operation, your heater produces a lot of flyash. This flyash will collect in the vent pipes and inside your pellet heater and restricts the flow of flue gases. Incomplete combustion occurs during start-up, shutdown and incorrect operation of your heater. Incomplete combustion creates soot which will also collect in the vent pipes and within the heater. The soot and flyash deposits in your heater and venting system is harmful to the performance of your heater. Improper maintenance leads to poor performance and component failure which can be

dangerous. Please adhere to the following maintenance schedule:

Do not use abrasive chemicals to clean the heater and/or labels placed on the heater. These chemicals can damage both the paint and labels on the heater.

ALLOW THE HEATER TO COOL TO ROOM TEMPERATURE AND UNPLUG THE HEATER BEFORE PERFORMING ANY MAINTENANCE.

Before each heating season:

1. Clean the venting system. It is imperative that you check the venting system for any blockages after any prolonged shut down period. If there is a significant amount of soot build up, it should be removed to prevent the risk of a chimney fire. By making sure the exhaust venting system and the heater itself are being maintained properly and cleaned on a regular basis, you reduce the likelihood of a chimney fire. Please contact your local building or fire officials in your area for information on how to handle a chimney fire. Have a plan of action ready in case a chimney fire occurs.
2. Clean behind the back heat shield as well as all exhaust passages. Ashes can build up behind the back heat shield and inside the exhaust passages. Firstly, the side heat shields must be removed by unscrewing the 2 bolts holding them in place. Now you will be able to access the 4 mounting bolts securing the back heat shield in place. Remove the 4 bolts and remove the back heat shield from the pellet stove. Using a brush, remove all of the ashes that have built up on the back wall of the combustion chamber, on the inside of the heat shield as well as in the exhaust passage. Inspect the auger chute gasket at this time. Make sure the gasket is still in good condition and that it is in the original position when the back heat shield is bolted back into place. Make sure to clean behind the back heat shield after every 3 tons of fuel burned. See Figure 20 for removal of the heat shields.

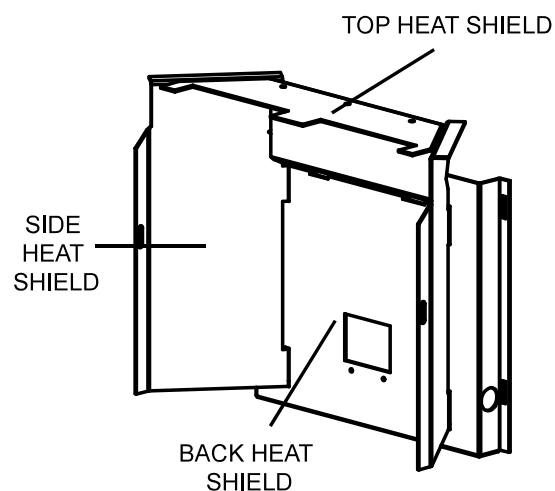

Figure 20. Cast iron stove heat shields.

3. Clean the exhaust fan housing. Ash accumulation on the fan blades will reduce the life of your exhaust fan. Frequent cleaning will help extend the life of this component. Open the left side panel to access the exhaust fan. Using a Common (flat head) screwdriver, remove the 6 sheet metal screws holding the fan motor to the housing (see Figure 21). Using a brush, clean all of the ash from the exhaust fan blades and housing.

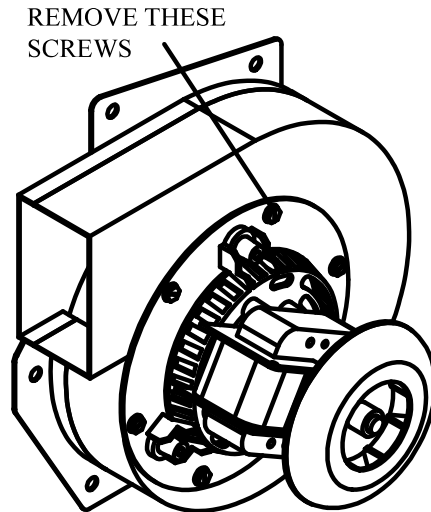

Figure 21. Exhaust fan assembly.

4. Inspect the condition of the door gasket periodically and replace it as necessary. It is important to make sure the door gaskets are in good condition. Gaskets in poor condition will not allow the door to seal properly and the heater will not function as efficiently.
5. Oil the circulation fan motor. To oil the motor bearings, the right side cover panel must first be opened. This is done by removing the 2 bolts securing the panel to the casting as well as removing the screws holding the panel to the hopper and base plate. Use a Robertson (square head) or Common (flat head) screwdriver to remove the screws. You will now be able to remove the panel and access the circulation fan. There are 2 oil ports located on top of the motor (one near the end and one near the fan housing as shown in Figure 23). There may be rubber plugs in one or both of these oil ports. These plugs must be removed prior to and replaced after oiling. Place a few drops of light oil, such as sewing machine oil, in each port.

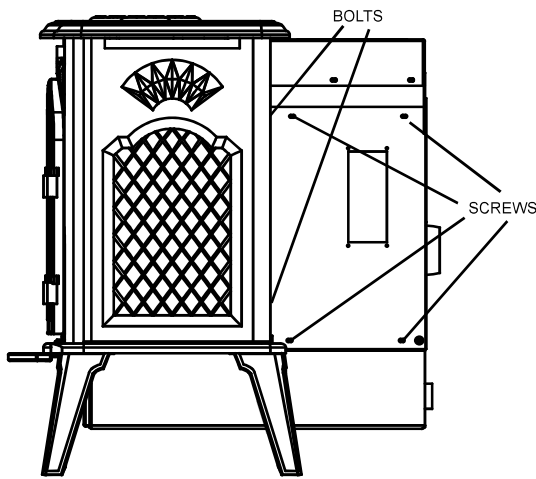

Figure 22. Bolts and screws securing the right side cover panel to the stove.

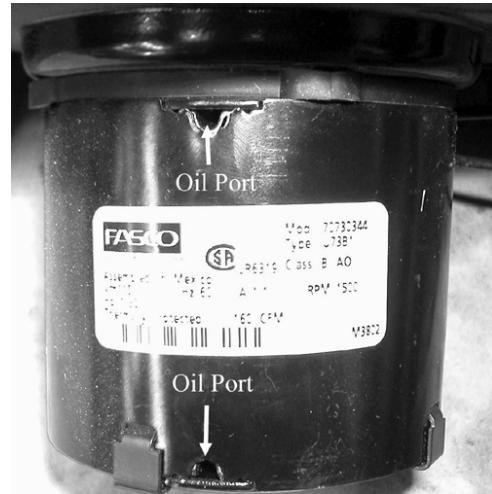

Figure 23. Oil ports on a circulation fan.

6. Perform weekly maintenance.

Weekly or more frequently if needed:

- a. Pull and push the heat exchanger tube cleaning rod which is located in the center, above the door (see Figure 24) when the stove is cold. This will remove the ash deposits on the heat exchanger tubes. The removed ash will fall on the top heat shield, located in the burn chamber.

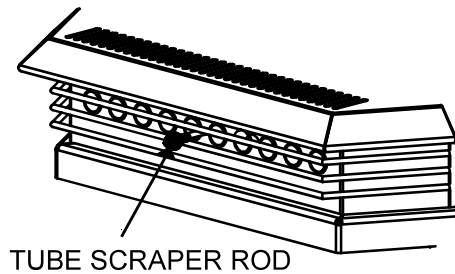

Figure 24. Tube scraper rod to clean heat exchanger tubes.

- b. Lift the top heat shield. Remove it carefully as there may be a significant amount of ash on it. Dump the ashes into the burn chamber.
- c. Using a brush, clean the top heat shield and remove it from the heater.
- d. Remove the burn pot, burn pot stand and splash guard (Figure 25) and clean them thoroughly. Lift the burn pot and splash guard to remove. Lift up on the burn pot stand and pull towards you to remove. Make sure there are no ashes remaining in the burn pot stand and that all the holes in the burn pot are clear. Failure to do so can be a fire hazard. Place all ashes into a metal container with a tight fitting lid.

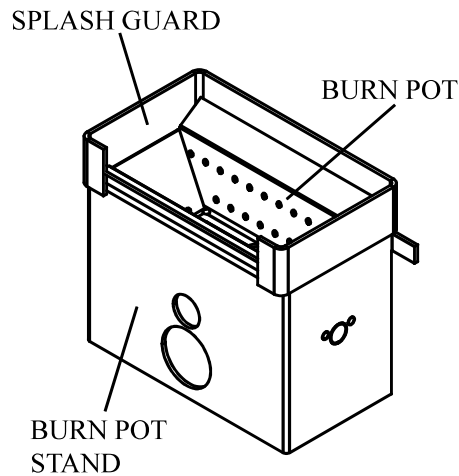

Figure 25. Burn pot stand assembly.

- e. Using a brush, clean the walls and floor of the burn chamber.
- f. To remove ashes in the burn chamber area you will need to remove the ash tray. Turn the 2 coil handles, located on the ash tray as shown in Figure 26, counter-clockwise to release the latch mechanism. Pull the ash tray out and place all of the ashes into a metal container with a tight fitting lid. Replacement of ash tray is reverse of removal. An alternate method to cleaning the ashes in the burn chamber area is to purchase a pellet vacuum. These vacuums are specifically designed for the removal of ashes in a pellet stove. Please visit the website www.lovelessash.com to find the closest dealer near you.

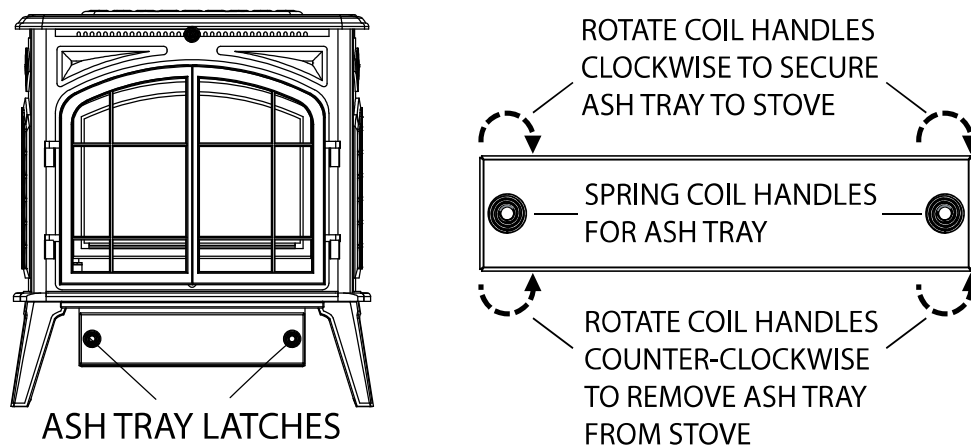

Figure 26. Ash tray for **KOZI** Previa Cast Iron pellet stove.

Disposal of Ashes - Ashes should be placed in a metal container with a tight fitting lid. The closed container of ashes should be placed on a noncombustible floor or on the ground, well away from all combustible materials, pending final disposal. If the ashes are disposed of by burial in soil or otherwise locally dispersed, they should be retained in the closed container until all cinders have thoroughly cooled. Do not place any other waste materials in this container.

- g. Empty out the hopper once every 2 weeks. Vacuum all of the sawdust build up in the hopper and auger chute opening. Cleaning out the sawdust from the hopper will help prevent from a hopper fire from occurring.
- h. Re-install all removed parts in their original positions.
- i. Clean the glass with a mild glass cleaner when dirty. DO NOT clean the glass when the door is hot. Cleaning the glass will allow you to see the flame and how it is burning. This is very important to see if the heater is burning properly or not. DO NOT hit the glass or slam the door shut. This may cause the glass to crack or break. DO NOT operate the heater if the glass is cracked or broken. DO NOT replace the glass with any type of glass other than an APR Industries Ltd. factory approved glass. If the glass cracks or breaks, turn the heater OFF. DO NOT operate the heater until the glass has been replaced.

NOTE: Depending on the type of fuel you use and the frequency that you use the pellet stove, you may need to clean the stove more frequently.

After each heating season:

- a. Remove all the pellet fuel from the hopper. Run the heater to empty the auger tube. Vacuum the hopper and auger tube. Clean the rest of the heater.
- b. Open up both side panels. Clean out any pellets, dust, ashes or debris that may have built up in the back of the pellet stove.

VI. TROUBLESHOOTING GUIDE

1. Troubleshooting

Your **KOZI** pellet heater is equipped with a diagnostic light feature. When a problem occurs, the heat setting bar graph will light up (blink) to indicate where the problem may be. Each light has been numbered for easy identification. The chart below has been included to help you determine which corrective action should be taken. A complete description of each corrective action is included in the following pages of this manual. Some problems, such as flame problems, will not cause the diagnostic lights to blink.

<i>MX2</i> Control Trouble Shooting Guide				
Problem	Light Status	Possible Causes	Remedy	
Heater will not feed pellets.	All lights off	No power.	Check to see if heater is plugged in.	
			Check fuse on control board	
			Check electrical outlet for power.	
	#2 light blinks (Pressure system failure)		Exhaust vent and exhaust fan are plugged	Clean exhaust venting and exhaust fan.
			Exhaust passage and exhaust box pressure tap are plugged.	Clean exhaust passage and pressure tap.
			Pressure switch tube is cracked or broken.	Replace pressure switch tube.
			Pressure switch has failed.	Replace pressure switch.
			Exhaust fan has failed.	Replace exhaust fan.
	#3 light blinks (Proof of flame failure)		Hopper is empty.	Fill hopper with fuel.
			Exhaust fan thermal disk has failed.	Replace exhaust fan thermal disk.
			Auger jam.	Empty hopper and clean out auger.
	#4 light blinks		Auger motor has failed.	Replace auger motor.
			Manual reset thermal disk has failed.	Replace manual reset thermal disk.
Stove won't turn off.	Normal	Exhaust fan thermal disk has failed.	Replace exhaust fan thermal disk.	
		Stove in "Cool Down" mode.	Allow sufficient time for the stove to cool down.	
		<i>MX2</i> Control board has failed.	Replace <i>MX2</i> Control Board.	
Stove will not light.	Normal	No pellet fuel.	Add fuel to the hopper.	
		Burn pot dirty.	Clean burn pot.	
		Fuse blown.	Replace fuse.	
		Igniter slipped out of igniter tube.	Push igniter back into place.	
		Igniter has failed.	Replace igniter.	
		No power to igniter.	Replace <i>MX2</i> Control Board.	
Fuel piles up.	Normal	Burn pot dirty.	Clean burn pot.	
		Poor quality fuel.	Change fuel supplier.	
Short flame on high feed.		Poor quality fuel.	Change fuel supplier.	
		Heat exchanger requires cleaning.	Clean heat exchanger.	
Too large and dark orange flame.		Poor quality fuel.	Change fuel supplier.	
Smell of smoke in room.	Normal	The pellet venting joints not sealed properly.	Seal all joints with high temperature RTV silicone sealant.	

2. Corrective Actions

BEFORE PERFORMING ANY SERVICE, MAKE SURE THE HEATER IS COLD AND UNPLUGGED. We strongly recommend using qualified service people.

i. Proof of Flame Failure

- a. Verify that there is sufficient fuel in the hopper and that the heater has run for long enough to fill the auger tube (see “Starting Your Heater for the First Time” section).
- b. Verify that the auger has not jammed. Occasionally, fuel can become lodged in the auger and prevent the auger’s proper operation. Open one of the side panels and grasp the auger motor. Move the auger motor back and forth. It may be difficult to move at first, but should move relatively freely. If it will not move, empty the hopper and look for foreign objects in the auger.
- c. Verify that the auger motor is working. Plug the heater in. Without lighting a fire, start the heater. Verify that the white plastic fan on the auger motor is turning. If it does not turn, check for power at the auger motor and replace the auger motor as necessary. Remember to unplug the heater before attempting any service.
- d. Verify that the shaft of the auger motor is secured to the auger properly. Empty the hopper and locate the auger bolt (1/4” square head) on the auger. Remove the bolt and make sure the hole is aligned with the flat portion of the auger motor shaft. Reinstall the bolt and tighten.
- e. If none of the above resolve your problem, contact your local **KOZI** dealer.

ii. Pressure Switch Failure

- a. Verify that the heater is clean. Clean all venting and exhaust passages in the stove. Refer to the “Maintenance” section for more information on cleaning your heater.
- b. Verify that the pressure switch tube is not cracked or loose. Replace as required. Also, verify that the pressure port on the stove is clean.
- c. Verify that the exhaust fan is in good working condition. Without lighting a fire, start the heater. You should hear the exhaust fan start and come to full speed relatively quickly. If the exhaust fan is not working or is slow to start, check for power at the exhaust fan and replace the exhaust fan as necessary. Remember to unplug the heater before attempting any service.
- d. Verify that the pressure switch is working properly. Apply a slight

- vacuum to the pressure switch tube. The pressure switch should “click”. Replace as necessary. NOTE: pressure switches rarely fail.
- e. If none of the above resolve your problem, contact your local **KOZI** dealer.

iii. Manual Reset Thermal Disk Failure

This is a safety device and should not be reset unless the cause of the problem is found and repaired. Typical causes are power failures while the heater is running and circulation fan failure.

- a. Verify that the circulation fan is in good working condition. Plug the heater in. Without lighting a fire, start the heater and press the “FAN” button. You should feel a significant amount of air coming from the heat exchanger. If no air is felt, check for power at the circulation fan and replace the circulation fan as necessary. Remember to unplug the heater before attempting any service.
- b. Verify that the circulation fan thermal disk is working properly.
- c. Reset the Manual Reset Thermal Disk. Open the right side panel. Mounted on the back of the body of the stove you will see 2 thermal disks. One of these will have a red, reset button. Press the button to reset the thermal disk.
- d. If your Manual Reset Thermal Disk is continuously tripping, contact your local **KOZI** dealer.

iv. Ignition Failure

- a. Verify for power at the igniter and replace as necessary.
- b. Verify that the burn pot is clean. See the “Maintenance” section for more information on cleaning your heater.
- c. Verify that the igniter is in the correct position. Remove the back panel on your stove to access the igniter. When the stove is cold and unplugged, tap the brass bushing on the igniter forward with a mallet to ensure that the igniter hasn’t slipped out at the back of the stove.
- d. If none of the above resolve your problem, contact your local **KOZI** dealer.

v. Overheating

This problem occurs when the circulation fan setting is too low for the amount of heat generated or if the circulation fan fails.

- a. Verify that the circulation fan is working properly. With the heater plugged in, start the heater. Press the FAN button. You should feel

air coming from the heat exchanger. If not, check if there is power coming to the circulation fan and replace circulation fan or control board as necessary.

- b. If the heat is not needed, reduce the feed and damper accordingly. Continue to reduce the feed until the circulation fan does not run on high.
- c. If none of the above resolve your problem, contact your local **KOZI** dealer.

vi. Lack of Air

The most common cause of flame problems are improperly sealed doors and ash trays, dirty heaters, poor fuel, improper installation and improper damper adjustment.

- a. Verify that the door, ash tray and ash gates are properly closed and sealed. Replace gaskets as necessary.
- b. Clean your heater thoroughly. Refer to the “Before Each Heating Season” section found in the “Maintenance” section for detailed cleaning instructions.
- c. Adjust your heater properly. Refer to the “Adjusting Your Heater” section.
- d. Try using various brands of fuel. Although most manufacturers claim to produce “premium” grade wood pellets, contaminants and moisture will affect fuel quality.
- e. If your heater is less than one year old, your venting and/or intake may be too restrictive. Contact your local **KOZI** dealer for venting recommendations.
- f. If none of the above resolve your problems, contact your local **KOZI** dealer.

VII. DIAGRAMS AND PARTS LIST

1. KOZI MX2™ Control Circuit Diagram

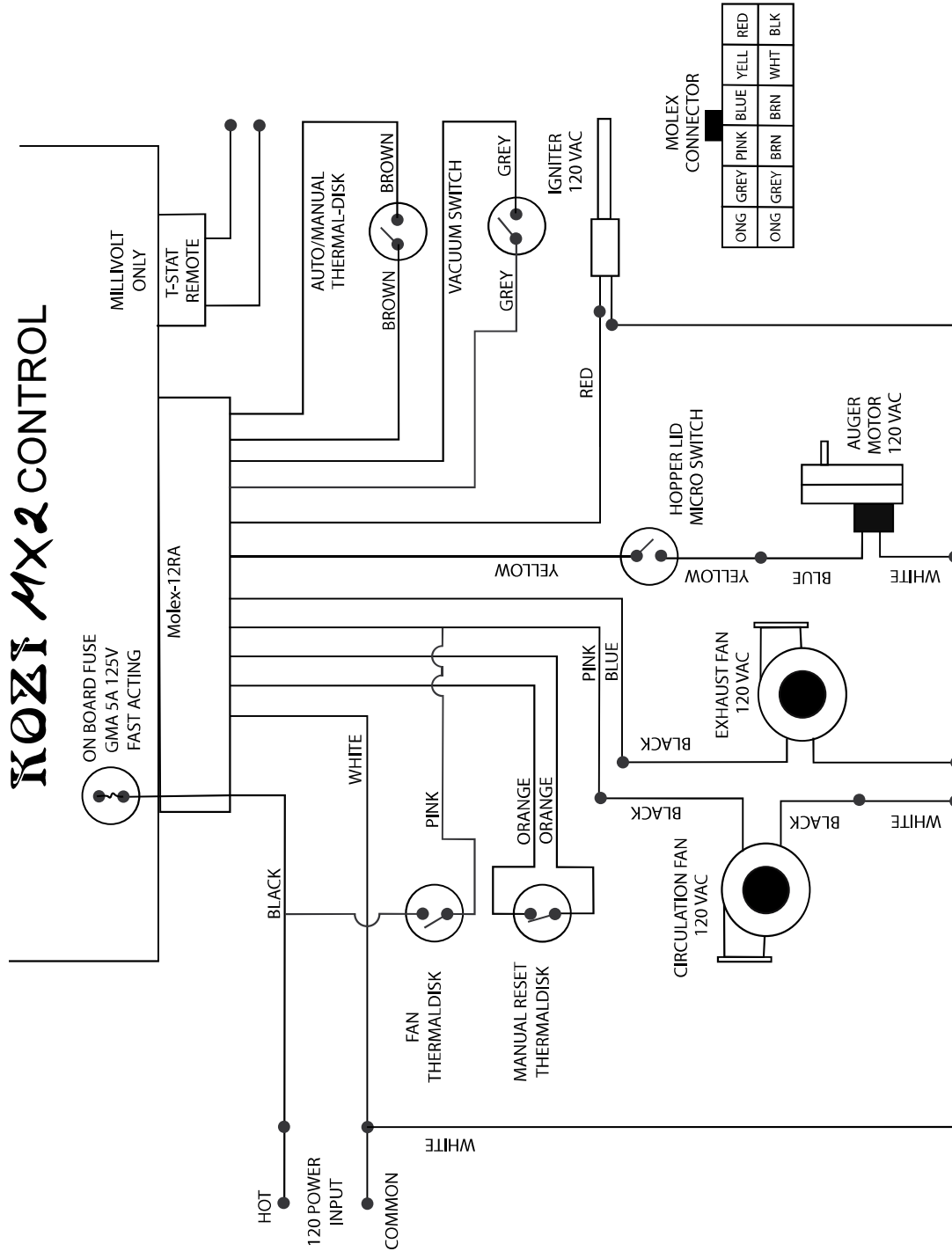

2. Stove Cross Section

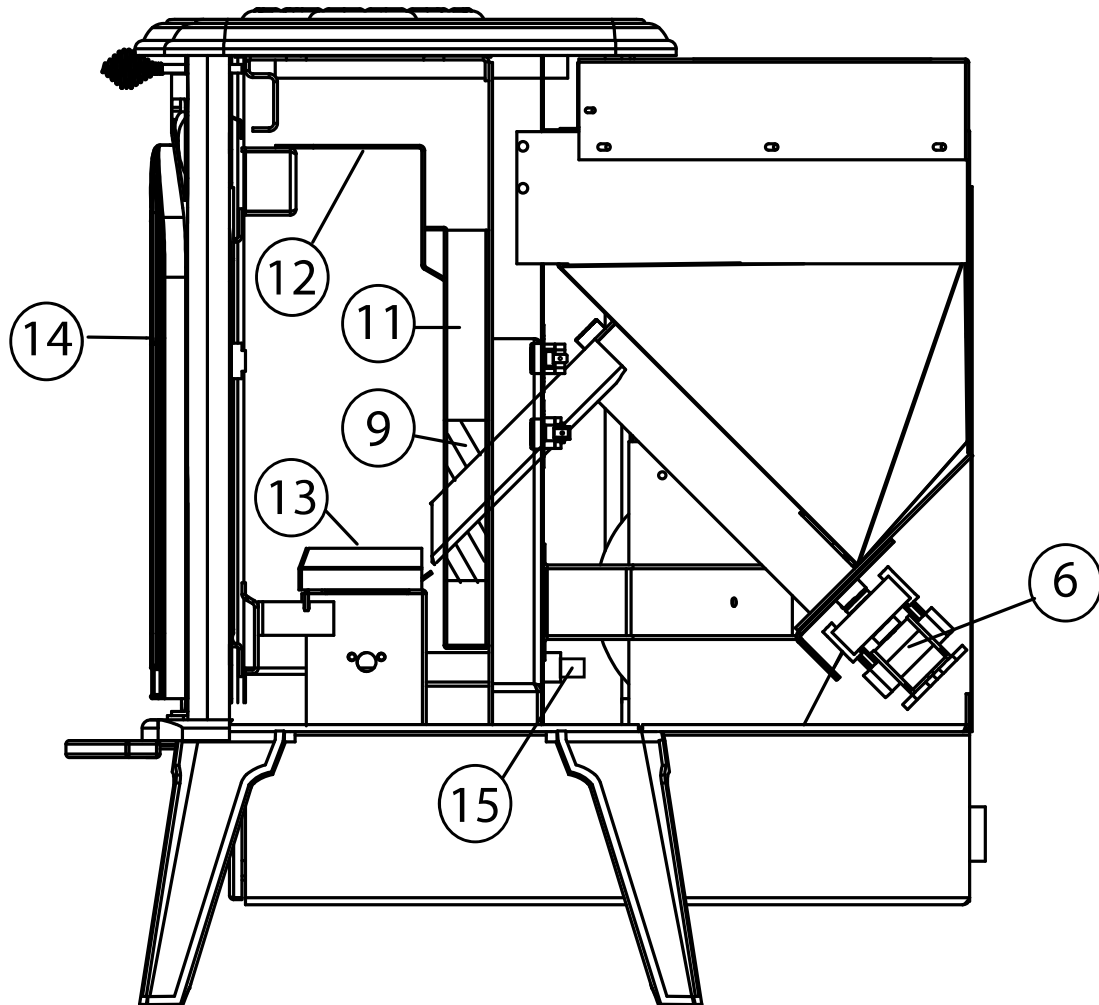

3. Equipment Compartment

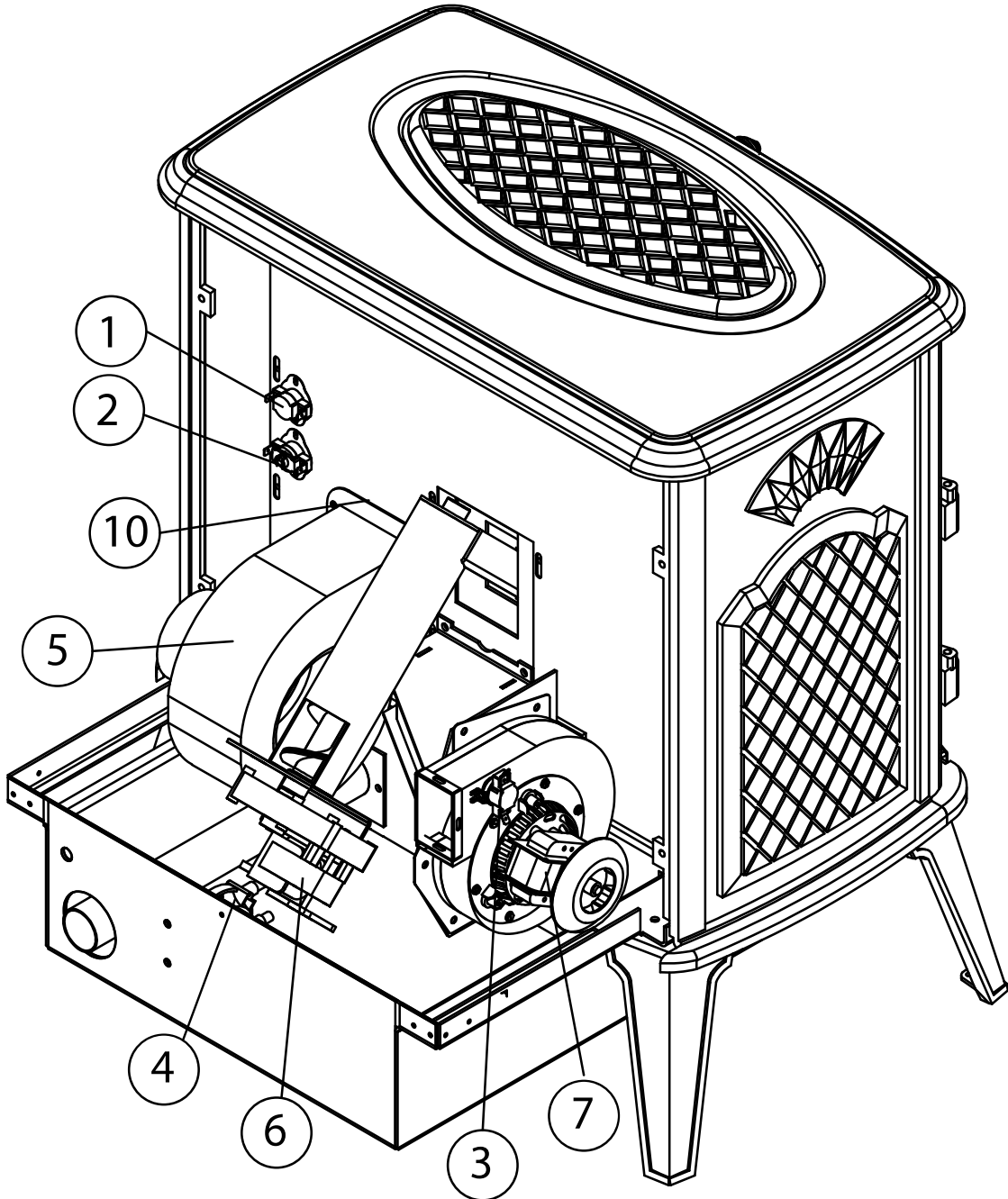

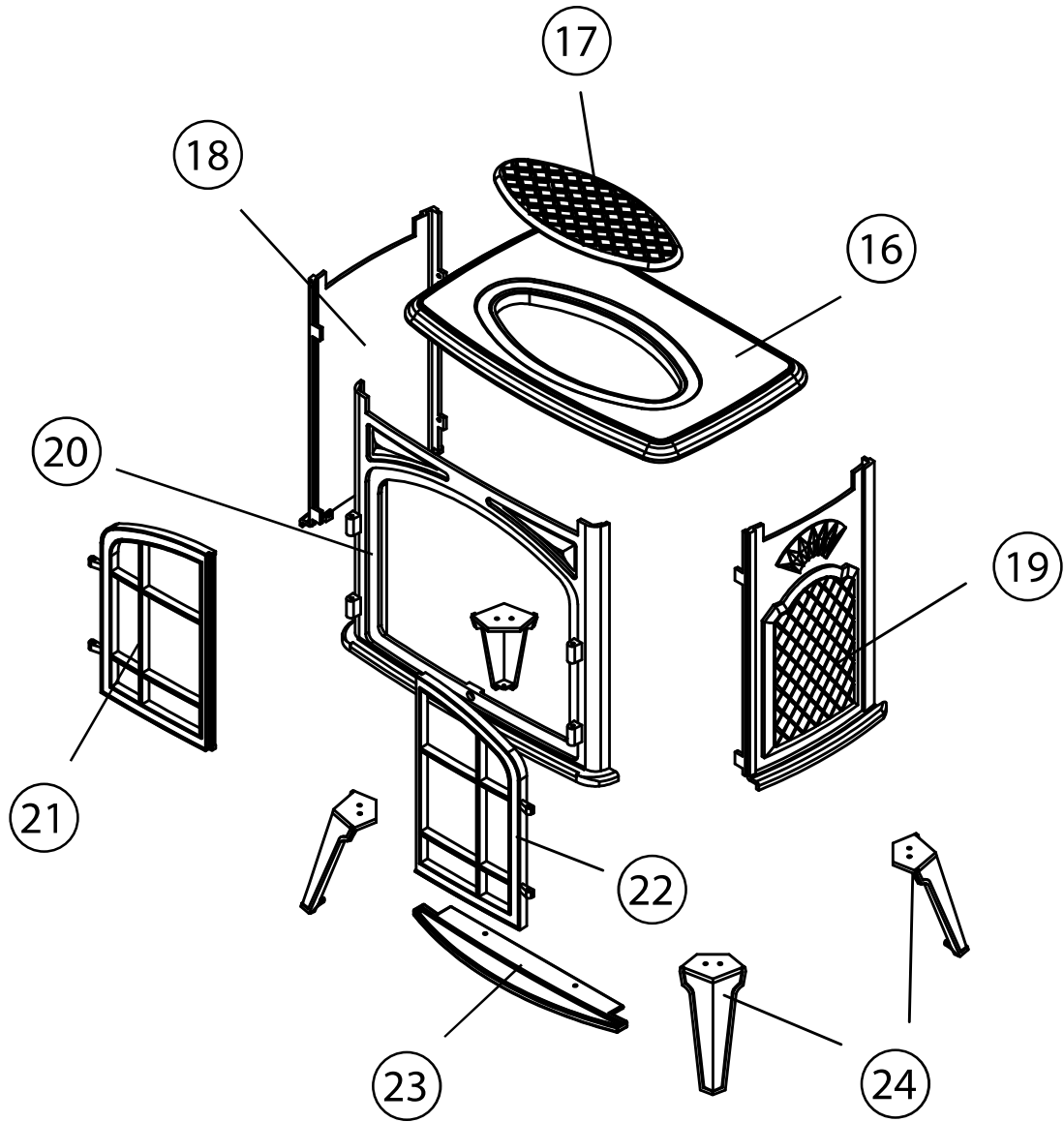

4. Parts List

Item No.	Description	Part #
Electrical Components		
1	Circulation Fan Override, Thermal disk	TDKLMT04
2	Manual Reset, Overheat Thermal disk	TDKMR01
3	Exhaust Temperature Thermal disk.	TDKLMT01
4	Static Pressure Switch	SWC09902
5	Circulation Fan	FAN12001
6	Auger Motor	MTR12001
7	Exhaust Fan	FAN12003
8	<i>MX2</i> TM Control Board	CBDKZ001
Gaskets & Gasket Kits		
Not Shown	Ash Tray Rope Gasket	GKT00304
9	Auger Chute Gasket Kit	GKT9900
10	Circulation Fan Gasket	GKT00202
Not Shown	Tadpole Door & Glass Gasket	GKT00308
Not Shown	Exhaust Fan Motor Mounting Gasket (Round)	GKT00208
Not Shown	Exhaust Fan Mounting Gasket (Polygon Shape)	GKT00209
Heat Shields & Other Parts		
11	Back Heat Shield	PRESBCKSL
Not Shown	Side Heat Shield Left	PRESHTSL
Not Shown	Side Heat Shield Right	PRESHTSR
12	Top Heat Shield	PRESTPHSL
13	Burner Pot	BPOT1005
14	Door Glass, Cast Iron, Arched Door	GLSCPREA
Not Shown	Static Pressure Switch Tube	TUBSPS01
15	Electric Igniter, Including Cartridge	EC2-HA-120
Heat Shields & Other Parts		
16	Top Casting	CASTTOPC
17	Top Casting Mounting Plate	CASTTCMP
18	Left Side Casting	CASTLHSC
19	Right Side Casting	CASTRHSC
20	Front Casting	CASTFRNT
21	Left Door Casting	CASTLHSD
22	Right Door Casting	CASTRHSD
23	Casting Hearth Lip	CASTHRTH
24	Casting Legs	CASTLEGS
If you don't see the part you need, please contact your local KOZI dealer.		

VIII. WARRANTY

APR Industries Ltd. honors a five year, limited warranty on all steel fabricated parts and a one year warranty on electrical parts to the original purchaser. The warranty is non-transferable and the coverage begins from the original date of the purchase.

The following items are NOT covered under warranty:

- Glass
- Gasket and Seals
- Cast Iron Body Components
- Ceramic Bricks
- Burn Pot
- Paint and Powder Coating
- Gold Plating
- Inner Heat Shields
- Auger Motor
- Self Igniter
- Glass Saver™

The limited warranty covers defects in the material and poor workmanship as long as the heater has been installed and operated in accordance with the Owner's Manual. Warranty is null and void if the heater is misused. It is the option of APR Industries Ltd. whether to repair or replace the parts.

To start a warranty claim, please contact your **KOZI** dealer. You must supply your **KOZI** dealer with the model, serial number and the proof of purchase of your **KOZI** product. APR Industries Ltd. may require that part(s) be returned/shipped back for inspection. Digital pictures may also be needed to support the warranty claim.

Prior to shipping a defective unit or component part(s) to APR Industries Ltd., a Return Authorization (RA) number is required from your **KOZI** dealer. Any shipments received at our facility without an RA number will not be accepted and automatically returned to the sender. The customer is responsible for all shipping costs to and from the factory.

Replace broken or defective components only with approved **KOZI** parts. Any damage occurred by the use of any unauthorized parts will void this warranty.

Contact your dealer for further warranty information.

1. Warranty Registration Card

Please fill out the Warranty Registration Card and mail it to the following address:

APR Industries Ltd.
c/o Warranty Department
1354 Waverley Street
Winnipeg, MB
Canada, R3T 0P5

Make sure to attach a **COPY** of your proof of purchase along with the warranty registration card. Make sure to keep the original copy of your proof of purchase. You can also register your pellet stove online at www.kozistoves.com/warranty.php.

CUT HERE



WARRANTY REGISTRATION CARD

Customer: Name: _____
Address: _____

Postal Code: _____ Country: _____
Phone Number: _____

Product: Type: Stove Insert Fireplace

Model: **KOZİ** _____
Serial Number: _____
Date Purchased: _____

Dealer: Name: _____
Address: _____

SERIAL NUMBER: _____

MODEL/TYPE: _____

NOTES: _____
