



MODEL 100

OWNER'S MANUAL

WOOD PELLET BURNING HEATER

* INSTALLATION * OPERATION * SERVICE * PARTS *



CAUTION

Read all instruction carefully before starting the installation or operating the heater.
Save this manual for future reference.

Manufactured By:
APR Industries Ltd.
1354 Waverley Street
Winnipeg, Manitoba R3T 0P5
Canada

WWW.KOZISTOVES.COM

Lithoid in Canada
Rev. April 2003

Contents

I. Installation And Operation Manual	4
1. Preamble : Instructions for Safe Installation and Operation.	4
2. Clearance to Combustible Walls	5
2.1 Free Standing Stove	5
2.2 Free Standing Stove Installed in Alcove.	5
2.3 Insert Installed in Masonry or Listed Factory Built Fireplace.	5
2.4 Other Clearances and Recommendations	6
3. Electrical Requirements	7
4. Venting System	7
4.1 Exhaust Vent Pipe Requirements	7
4.2 Combustion Air Intake Requirements	8
4.3 Exhaust Vent Termination Requirements	9
5. Location of the Heater	9
6. Typical Installation Configurations	10
II. Understanding Your Pellet Burning Heater	12
1. Component Description	12
1.1 General Overview	12
1.2 Exhaust Fan	13
1.3 Burn Pot	13
1.4 Circulation Fan	13
1.5 Troubleshooting Module Status Lights	13
1.6 Auger Cycle Timer	13
1.7 High Temperature Manual Reset Thermal Disk	13
1.8 Pressure Switch.	14
2. Heater Operation	14
2.1 Circulation Fan Speed Control	14
2.2 Feed Control Knob	14
2.3 Damper Control	14
2.4 Start Button	15
2.5 Starting your Heater for the First Time	15
2.6 Starting (lighting) your Heater	15
2.7 Stopping your Heater	16
2.8 Adjusting your Heater	16
III. Maintenance	17
IV. Trouble Shooting Guide	18
V. Diagrams and Parts List	19
1. KOZ1 100 Circuit Diagram	19
2. Stove Cross Section	20
3. Equipment Compartment	21
4. Parts List	22
5. Accessories List	23
VI. WARRANTY	23

I. Installation And Operation Manual

This heater is suitable for both mobile home and conventional home installations. Read all instructions carefully before starting installation. Save this manual for future reference.

1. Preamble : Instructions for Safe Installation and Operation.

1. Read these instructions carefully. Failure to follow them could cause malfunction or damage to the heater, property damage, bodily injury and even death.
2. Familiarize yourself with the operation of the heater. (See “Heater Operation” section). If you are not sure, ask your dealer for explanations on your heater’s operation.
3. The burn pot of this heater is designed for premium grade wood pellets. Pellets with too much fines and saw dust must be screened before use. **DO NOT USE WET PELLETS.** High ash content fuel will clog the burn pot holes and, as a result, the burn pot will require frequent cleaning.
4. Oil the motor bearings every 6 months. See “Maintenance” section for more details.
5. Check your local building codes. All installations must comply with their rulings.
6. This heater requires a minimum 6 inch (150 mm) floor protector in front of the heater. This is to catch any spillage that may occur during opening and closing of the door.
7. Use only UL/ULC listed Type Pl or Type L venting for the exhaust system. The heater is designed for use with 3 inch (76 mm) vent pipe. Avoid using long runs and too many bends. It may be necessary to increase the size of venting to 4 inches (102 mm) if long runs and too many bends are unavoidable. See “Venting System” for more details.
8. Combustion of wood pellet fuel deposits ashes in the heater and venting system. These ashes must be removed from the heater regularly (approximately once a week). If a high ash content fuel is used, cleaning must be done on a more frequent basis. The entire system must also be cleaned at the start of each heating season. A yearly inspection of the venting is highly recommended.

9. The heater must be turned off and allowed to cool before cleaning. Make sure there are no hot ashes or embers in the burn pot, ash tray or combustion chamber. Use a brush and scoop to clean. **DO NOT USE A VACUUM CLEANER.**

10. This heater is **POWER VENTED**. The vent pipes have positive pressure during operation. It is **IMPERATIVE** that all joints in the venting system be sealed to prevent any leakage of exhaust gases inside the house. All joints must be sealed using high temperature silicone sealer (RTV).

11. Store pellet fuel at a safe distance (at least 36 inches/1 meter) away from the heater.

12. Use of outside combustion air is **MANDATORY** (unless an APR Part No CV100 check valve is used). Connect the air intake of the heater to the exterior of the building with a non-combustible metal pipe with a minimum diameter of 2 inches (50 mm). Use of plastic pipe is not permitted.

13. Follow this manual carefully for proper installation. If you are uncertain, call your dealer. Most of the dealers have qualified and trained installers. We highly recommend the use of their services.

2. Clearance to Combustible Walls

2.1 Free Standing Stove

A. Side wall to Unit	5 inches	125 mm
B. Back wall to Unit	1 inch	25 mm
C. Corner to Unit	1 inch	25 mm

2.2 Free Standing Stove Installed in Alcove.

Alcove dimensions must be:

A. Minimum width	34 inches	865 mm
B. Minimum height	48 inches	1220 mm
C. Maximum depth	30 inches	760 mm

2.3 Insert Installed in Masonry or Listed Factory Built Fireplace.

Minimum clearance must be:

A. Side wall to Unit	5 inches	125 mm
B. Mantle to Unit	13 inches	330 mm
C. Top facing to Unit	13 inches	330 mm
D. Side facing to Unit	5 inches	125 mm
E. Floor Protector	6 inches	150 mm

2.4 Other Clearances and Recommendations

1. This heater can be mounted on a combustible floor provided that a non-combustible material, extending minimum of 6 inches (150 mm) in front of the heater, protects the combustible floor.
2. When installed in a mobile home, the heater must be anchored to the floor.
3. For a pictorial view of clearances to combustibles, see the safety test label attached to your stove. A copy of this label is provided here.



Warwick Hersey
CH USA

LISTED ROOM HEATER, PELLETIZED FUEL TYPE
ALSO FOR USE IN MOBILE HOMES
APPAREIL DE CHAUFFAGE RÉPERTORIÉ, À COMBUSTIBLE EN
GRAAULÉS PEUT ÊTRE UTILISÉ DANS UNE MAISON MOBILE

DO NOT REMOVE THIS LABEL.
NE PAS ENLEVER CETTE ÉTIQUETTE

SER. NO.
NO. DE SÉRIE

WH-

MODEL / MODÈLE: R021100 REPORT NO: 8437 (JULY 1992)
TESTED TO: UL - 1482 / UL - 5827 / APF DRAFT

MODÈLE: R021100 NO. DE RAPPORT: 8437 (JULIET 1992)
ÉPROUVÉ POUR RÉPONDRE AUX NORMES: UL - 1482 / UL - 5827 ET APF

THIS PELLET FIRED APPLIANCE HAS BEEN TESTED AND LISTED FOR USE IN MANUFACTURED HOMES IN ACCORDANCE WITH OREGON ADMINISTRATIVE RULES 91A-01-900 THROUGH 91B.

INSTALLATION: (SEE INSTRUCTIONS)
ELECTRICAL: (SEE INSTRUCTIONS) (SEE INSTRUCTIONS)
INSTALL AND USE ONLY IN ACCORDANCE WITH THE MANUFACTURER'S INSTALLATION AND OPERATION INSTRUCTIONS. SEE LOCAL BUILDING CODE AND MANUFACTURER'S INSTRUCTIONS FOR PRECAUTIONS REQUIRED FOR INSULATED VENT COMPONENTS THROUGH A COMBUSTIBLE WALL OR CEILING. CONTACT LOCAL BUILDING OR FIRE OFFICIALS ABOUT RESTRICTIONS AND INSTALLATION INSPECTION IN YOUR AREA. DO NOT CONNECT THIS UNIT TO A CHIMNEY FLUE SERVING ANOTHER APPLIANCE.

CET APPAREIL DE CHAUFFAGE À GRAAULÉS A ÉTÉ ÉPROUVÉ ET RÉPERTORIÉ POUR UNE UTILISATION DANS LES MAISONS CONSTRUITES CONFORMÉMENT AUX RÈGLES ADMINISTRATIVES DE L'OREGON 91A-01-900 À 91B.

INSTALLATION: (VOIR LES INSTRUCTIONS)
ÉLECTRIQUE: (VOIR LES INSTRUCTIONS)
INSTALLER ET UTILISER L'APPAREIL CONFORMÉMENT AUX INSTRUCTIONS D'INSTALLATION ET DE FONCTIONNEMENT DU FABRICANT - CONSULTER LE CODE LOCAL DE BÂTIMENT ET LES INSTRUCTIONS DU FABRICANT APRÈS AVOIR CONSULTÉ LES PRÉCAUTIONS EXIGÉES POUR L'INSTALLATION DES RACCORDEMENTS TRAVANT UN MUR OU UN PLAFOND COMBUSTIBLE. CONSULTER AVEC LES AUTORITÉS LOCALES EN MATIÈRE DE BÂTIMENT ET DE FEU CONCERNANT LES RÈGLES POUR CONSULTER LES RESTRICTIONS ET LES NORMES D'INSPECTION DES INSTALLATIONS DANS VOTRE RÉGION. NE PAS RACCORDER À UN TUYAU DE TRAVAIL DÉSERVANT UN AUTRE APPAREIL.

MINIMUM CLEARANCES TO COMBUSTIBLE CONSTRUCTION
- INSTALLED AS A FREE STANDING STOVE

A. SIDEWALL TO UNIT	- 5" / 125 mm
B. BACKWALL TO UNIT	- 1" / 25 mm
C. CORNER TO UNIT	- 1" / 25 mm
MIN. ALCOVE WIDTH	- 34" / 865 mm
MIN. ALCOVE HEIGHT	- 48" / 1220 mm
MAX. ALCOVE DEPTH	- 32" / 815 mm



DÉBOÎTEMENTS MINIMUMS DES ÉLÉMENTS DE CONSTRUCTION COMBUSTIBLES - INSTALLATION COMME POËLE NON ENCASTRÉE

A. ENTRE L'APPAREIL ET LE MUR LATÉRAL	- 5 PO / 125 mm
B. ENTRE L'APPAREIL ET LE MUR ARRIÈRE	- 1 PO / 25 mm
C. ENTRE L'APPAREIL ET LES CORNS	- 1 PO / 25 mm
LARGEUR MIN. DE L'ALCOVE	- 34 PO / 865 mm
HAUTEUR MIN. DE L'ALCOVE	- 48 PO / 1220 mm
PROFONDEUR MAX. DE L'ALCOVE	- 32 PO / 815 mm

COMBUSTIBLE FLOOR MUST BE PROTECTED BY A NON-COMBUSTIBLE MATERIAL EXTENDING TO THE FRONT (5" / 125 mm) AS SHOWN.

MINIMUM CLEARANCES TO COMBUSTIBLE CONSTRUCTION
- INSTALLED AS AN INSERT OR HEARTH MOUNTED STOVE FOR USE WITH MASONRY OR LISTED FACTORY-BUILT PREPLACES.

D. FLOOR PROTECTOR	- 6" / 150 mm
E. SIDEWALL TO UNIT	- 5" / 125 mm
F. MANTLE TO UNIT	- 12" / 300 mm
G. TOP FACING TO UNIT	- 12" / 300 mm
H. SIDE FACING TO UNIT	- 5" / 125 mm



DÉBOÎTEMENTS MINIMUMS DES ÉLÉMENTS DE CONSTRUCTION COMBUSTIBLES - INSTALLATION COMME APPAREIL ENCASTRÉ OU SUR UN ÂTRE DANS UN OUVRAGE DE MAÇONNERIE OU DANS UN FOYER RÉPERTORIÉ ET MONTÉ EN USINE

D. SOUS L'ÉLÉMENT DE PROTECTION	- 6 PO / 150 mm
E. EN TRE L'APPAREIL ET LE MUR LATÉRAL	- 5 PO / 125 mm
F. EN TRE L'APPAREIL ET LE BANCAL DE LA CHÈMINÉE	- 12 PO / 300 mm
G. EN TRE L'APPAREIL ET LE FAÏENÇAGE SUPÉRIEUR	- 12 PO / 300 mm
H. EN TRE L'APPAREIL ET LE FAÏENÇAGE LATÉRAL	- 5 PO / 125 mm

NE PAS UTILISER DES GRAAULÉS DE COMBUSTIBLE SOLIDE AU DELÀ DE 14 PO OU DE 370 PO DE DIAMÈTRE. NE PAS BRÛLER DE CHARBON. SURVEILLER LES PORTES D'OBSERVATION ET D'ÉVACUATION DES CENDRES AVANT DE PARE FONCTIONNER L'APPAREIL. NE REMPLACER LE VERRIN CLASSIC QU'AVEC DES ÉLÉMENTS ÉQUIVES POUR INSTALLATION EN RÉPERTORIÉ DE TYPE L OU PL DE 5 PO / 125 mm DE DIAMÈTRE. NE PAS BRÛLER DE COMBUSTIBLE ÉTIRÉ (S'ÉTIRANT) OU D'UN TYPE NON RÉPERTORIÉ. NE PAS BRÛLER UN TYPE D'ÉLÉMENT DE CHÈMINÉE RÉPERTORIÉ POUR MUR SIMPLE.

FOR USE WITH PELLETIZED LIGNITE OR SPLIT OAK, SOLID WOOD PELLETS ONLY. DO NOT BURN COAL. OPERATE ONLY WITH VIEWING DOOR AND ASH RESEALING DOORS CLOSED. REPLACE GLASS ONLY WITH CERAMIC GLASS. COMPONENTS REQUIRED FOR INSTALLATION: 2" x 1/8" DIAMETER LISTED TYRE L OR TYRE PL VENT, OUTSIDE COMBUSTION AIR INLET. FOR INSERT AND HEARTH MOUNT INSTALLATION, A LISTED SINGLE WALL CHIMNEY LINER MUST BE USED.

LIGHTING INSTRUCTIONS:
TURN SWITCH TO "OFF". PLACE A SMALL AMOUNT OF PELLETS AND PRESTARTER ON GRATE AND IGNITE. TIGHTLY CLOSE VIEWING DOOR AND TURN FUEL FEED TO MEDIUM. WHEN FIRE IS BURNING WELL, ADJUST FEED AND FAN CONTROLS AS NECESSARY.

SHUTDOWN INSTRUCTIONS: TURN FUEL FEED OFF. TURN SWITCH TO "OFF".

INSTRUCTIONS DE MISE À FEU:
BASCULER L'INTERRUPTEUR EN POSITION "ARRÊT". PLACER UNE PETITE QUANTITÉ DE GRAAULÉS ET DE DÉMARRÉ À MISE À FEU SUR LA GRILLE ET ALLUMER. FERMER SOULEMENT LA PORTE D'OBSERVATION ET RÉGLER L'ALIMENTATION EN COMBUSTIBLE À LA POSITION MOYENNE, LORSQUE L'APPAREIL CHAUFFE ADÉQUATEMENT, RÉGLER L'ALIMENTATION ET LES BÉTIÈRES AU BESOIN.

POUR FERMER L'APPAREIL: COUPER L'ALIMENTATION ET BASCULER L'INTERRUPTEUR EN POSITION "ARRÊT".



CAUTION
HOT WHILE IN OPERATION. DO NOT TOUCH. KEEP CHILDREN, CLOTHING AND FURNITURE AWAY. CONTACT MAY CAUSE SKIN BURNS. SEE NAMEPLATE AND INSTRUCTIONS.

MADE IN CANADA BY: APR INDUSTRIES LTD.
FABRIQUÉ AU CANADA PAR: WARRICK, MAN.

MISE EN GARDE
L'APPAREIL DEVIENT CHAUD LORSQU'IL FONCTIONNE. NE PAS TOUCHER. ÉLOIGNER LES ENFANTS, LES VÊTEMENTS ET LES MEUBLES DE L'APPAREIL. TOUT CONTACT PEUT ENTRAÎNER DES BRÛLURES. CONSULTER LA PLAQUE D'IDENTIFICATION ET LES INSTRUCTIONS.

Page 6

INSTALLATION COMMENT: We recommend that sufficient space be provided (minimum 20 inches/500 mm) on each side of the heater to service the equipment area. In case this is not possible, provisions must be made to pull out the heater for service.

FLOOR PROTECTION: A non-combustible material, extending a minimum of 6 inches (150 mm) in front of the heater is required.

3. Electrical Requirements

1. This heater is an electrical appliance and requires 120 Volts, 60 cycle, 3 Amp of electrical power.
2. This heater comes with a 5 ft. (1.5 M) long, grounded, electrical cord suitable to plug into any standard residential electrical outlet. The electrical outlet must be grounded.
3. When installed in a mobile home, the heater must be grounded to the steel chassis of the home (unless this is not required by local code).

4. Venting System

Before proceeding with the installation, the following sections should be reviewed:

Section 4 : Venting System

Section 5 : Location of the Heater

Section 6 : Typical Installation Configurations

4.1 Exhaust Vent Pipe Requirements

KOZ I pellet stoves have a negative pressure burn chamber. A high-pressure, radial blade fan pulls the air out of the burn chamber creating negative pressure (vacuum) inside the burn chamber. The air from outside the stove then rushes through the intake air tube, burn pot stand and burn pot to fill this vacuum. As this air passes through the burn pot it is used to burn the pellets. A proper size ULC/UL listed type PL or L venting should be used to provide the least resistance for movement of the combustion air.

This KOZ I pellet burner is certified for 3 inch exhaust venting. 3 inch venting is quite sufficient for most direct vent installations. However, installations with several elbows, long horizontal and/or vertical runs may add excessive resistance against the flow of air, which reduces the volume of air movement and creates burn problems. Use of 4 inch venting will reduce this resistance. A simple technique called 'EQUIVALENT VENT LENGTH (EVL)' can be used to determine whether 3 or 4 inch vent pipe should be used.

To calculate EVL use following formula:

for each 90 Elbow or T fitting	= add 5 EVL
for each 45 Elbow	= add 3 EVL
for each Horizontal run of vent	= add 1 EVL per foot of horizontal venting
for each Vertical run of vent	= add 1/2 EVL per foot of vertical venting

YOU MUST USE 4" STAINLESS STEEL RIGID OR FLEXIBLE VENT PIPE IF:

The EVL is 7 or more AND you are at or above an altitude of 3000 ft.

OR

The EVL is 15 or more

OR

Your unit is an Insert

DO NOT USE MAKESHIFT MATERIALS OR COMPROMISES IN THE INSTALLATION. IT IS A FIRE HAZARD.

Exhaust vent pipes are located on the exhaust side of the exhaust fan and are under positive pressure. Care must be taken to ensure that all joints are completely sealed to prevent any leakage of exhaust fumes into the house. If you smell smoke, the venting has not been properly sealed. Use only high temperature RTV silicone for sealing.

4.2 Combustion Air Intake Requirements

- A. It is mandatory to use outside air for combustion in ALL mobile or manufactured home installations.

- B. Conventional homes may use APR Part No: CV100 check valve in order to use internal combustion air. If a check valve is not used, the air intake of this heater must be connected to the exterior of the building using a non-combustible metal pipe, with a minimum 2 inch (50mm) diameter. Use of plastic pipes are not permitted.

- C. The combustion air intake must terminate into a vented space, i.e. outside, vented attic, or vented crawl space. This heater CAN NOT draw air from a closed space such as a closed garage, airtight crawl space or any other sealed room.

- D. The elevation of the combustion air intake must be below the exhaust vent. An elbow may be used to lower the air intake point below that of the exhaust vent.

- F. Excessive lengths and elbows on the air intake pipe will cause airflow restrictions. A minimum of 2 inch, or larger, venting should be used for longer lengths. Increase the venting size as needed.

4.3 Exhaust Vent Termination Requirements

- A. The exhaust vent must terminate into an open space. Under no circumstances is the vent allowed to terminate into closed or semi-closed spaces. Venting into a garage, under a sundeck, porch or any other space where the concentration of fumes may occur is prohibited.
- B. The exhaust vent must be at least:
- * 4 feet (1.2 m) below
 - * 4 feet (1.2 m) horizontally from, and
 - * 1 foot (0.30m) above
- any opening in the building such as door, window or ventilation air intake, etc.
- C. Exhaust vent opening must be minimum of:
- * 1 foot (0.3m) from the ground
 - * 24 inches (0.61m) from any combustible surface, i.e. fences, plants, combustible objects, etc.
 - * 7 feet (2.1 m) from any public walkway.
- D. Exhaust air is EXTREMELY HOT. Caution must be taken to avoid contact with children, people, plants, animals or any other object that will be affected by heat. It is recommended to use a vertical pipe to discharge the hot air at a safe elevation.
- E. Exhaust venting must be installed in accordance to the instructions provided by your pellet vent manufacturer.
- F. The vent terminal must have an end cap to protect against down draft and back draft created by severe wind conditions.

5. Location of the Heater

- A. This heater is NOT approved for bedroom installation.
- B. If installed in a mobile home, the heater must be anchored to the floor.

C. When installed in a conventional or a mobile home, check for:

- a. Clearance to combustibles.
 - b. Sufficient room to service the unit.
 - c. Access for outside combustion air.
 - d. Power within 6 feet (1.8m)
 - e. Access for exhaust venting.
 - f. EVL not exceeding 25ft (7.6m)
- See Exhaust Venting Requirements.

6. Typical Installation Configurations

The following figures describe some typical installations. Variations of these are possible. Common sense, safety and compliance with local building codes must be respected in any variation.

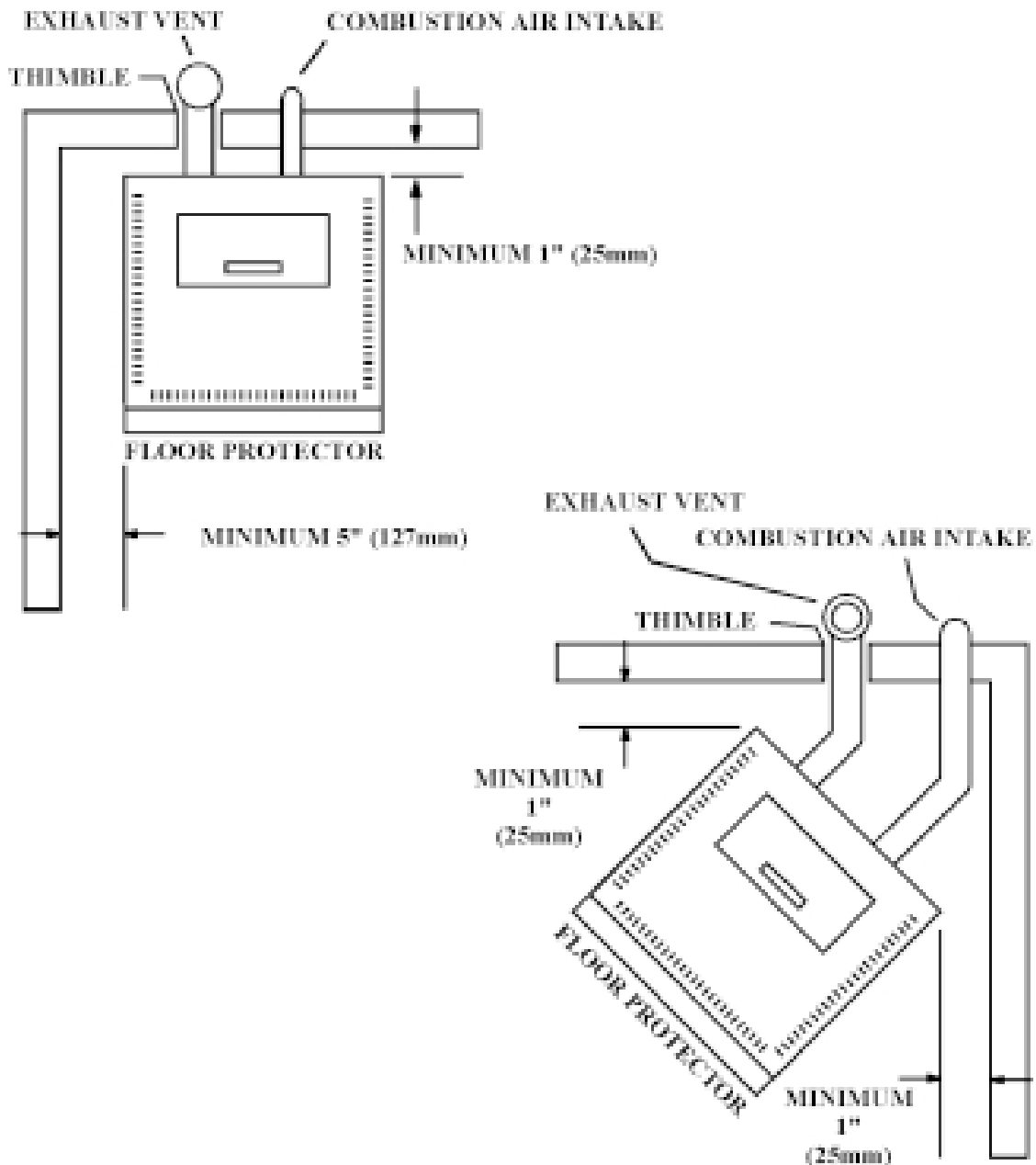

Typical floor plan - corner installation.

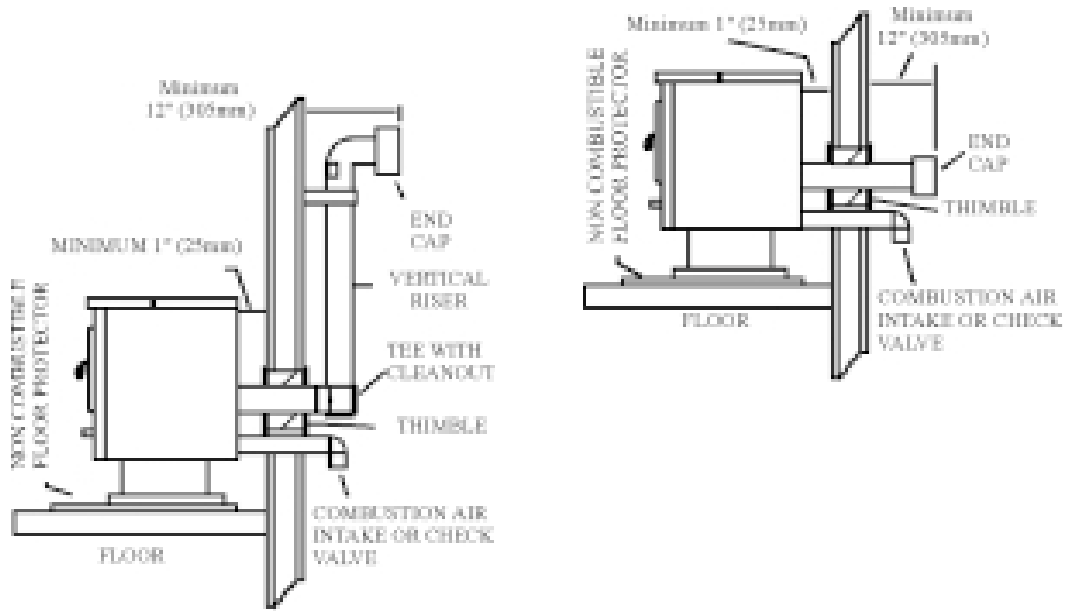

Free standing through the wall installation.

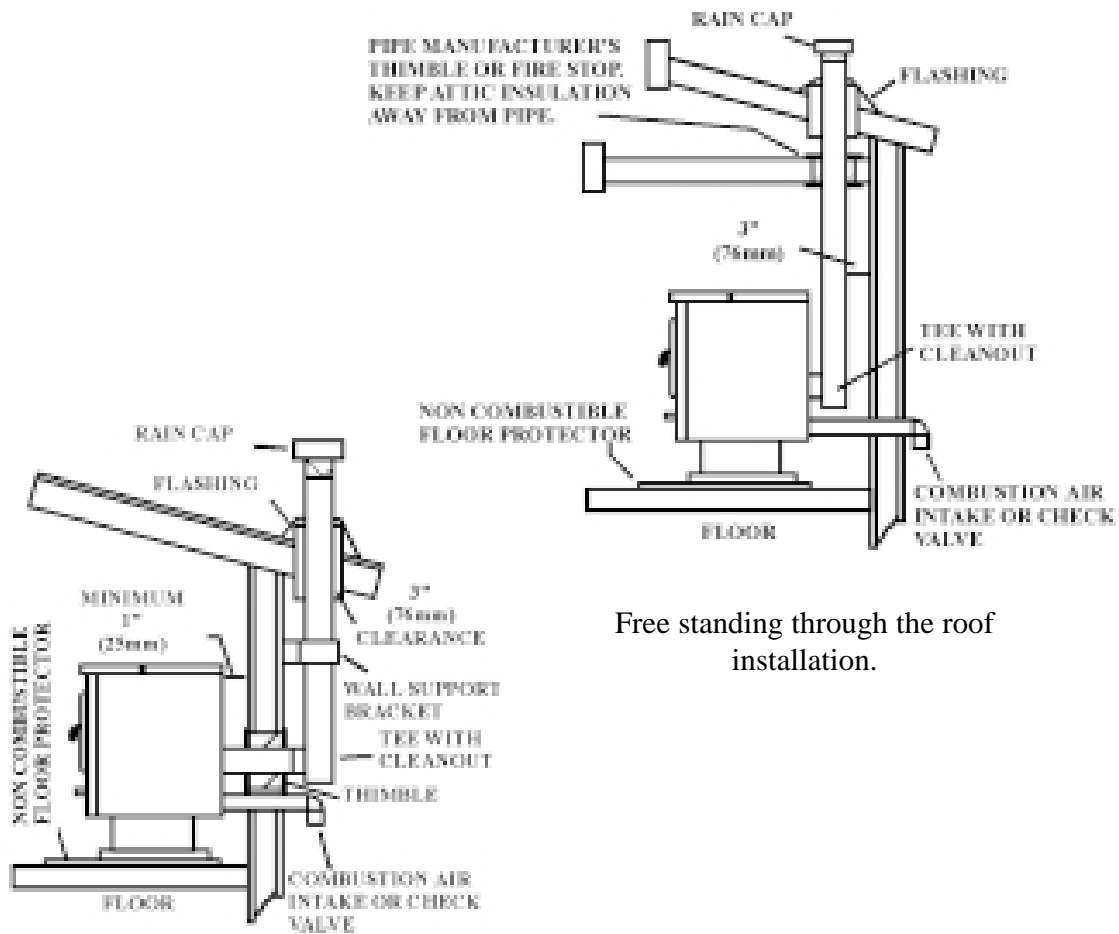

Free standing through the roof installation.

Free standing through the wall and the roof installation.

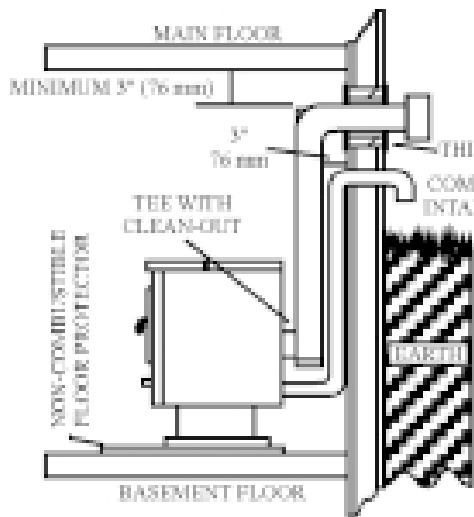

Free standing basement installation.

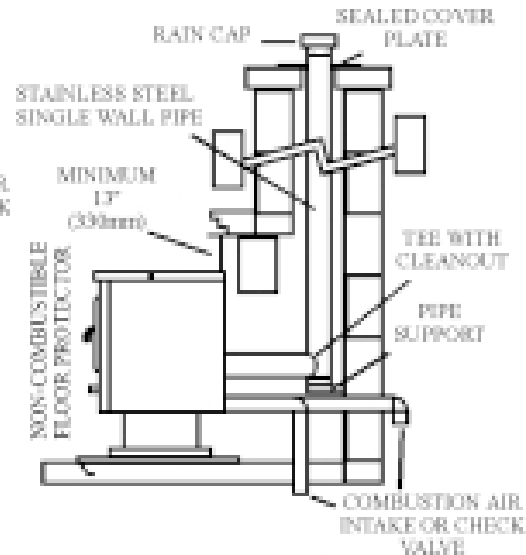

Free standing through a masonry chimney installation.

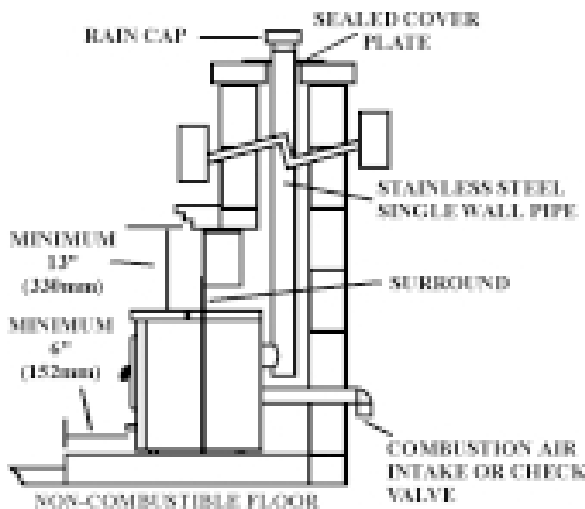

Factory built zero clearance or masonry fireplace insert installation.

II. Understanding Your Pellet Burning Heater

1. Component Description

1.1 General Overview

The first step in understanding your new KOZl heater is to familiarize yourself with it's operation. Your heater has 3 main systems: Combustion, Circulation and Feed. The combustion system includes the air intake, burn pot, exhaust fan and exhaust venting. The circulation system consists of a circulation fan, fan speed control and heat exchanger. The feed system is made up of an auger motor and various safety devices. Each part of these systems will be described below in detail. A description of the operation and the controls for your stove is provided in the section entitled "Heater Operation".

1.2 Exhaust Fan

The purpose of the exhaust fan is to remove the smoke from the combustion chamber. The exhaust fan sucks air from the air intake, through the burn pot and heat exchanger and pushes it through the venting. This fan is a fixed feed fan which is ON whenever the heater starts and remains on until the stove is cool. **THIS FAN CANNOT BE TURNED OFF MANUALLY.** Failure of this fan will result in a complete system shut down.

1.3 Burn Pot

The burn pot is the receptacle in which the pellet fuel is burned. This portion of the stove requires frequent cleaning since it controls the efficiency of the combustion process. It is recommended that the burn pot be cleaned every time the hopper is filled and thoroughly scraped periodically.

1.4 Circulation Fan

The purpose of the circulation fan is to circulate the unheated room air through the heat exchanger. The circulation fan speed can be controlled by the fan speed control (described below) but cannot be shut off completely. The control system has a built in safety that allows it to override the fan speed control in the event that the heater overheats. As your unit begins to overheat, the circulation fan will come on high to remove some of the excess heat. As your unit cools, the circulation fan will return to its original setting. If the circulation fan cannot remove the heat fast enough, a second safety, the high temperature manual reset disk, will shut the feed mechanism off.

1.5 Troubleshooting Module Status Lights

Your unit is equipped with 3 status lights. Each light indicates a different safety device. Together, these lights are intended to keep you informed as to what is happening in the feed system. The top light indicates the status of the auger cycle timer, the middle light indicates the high temperature manual reset thermal disk and the bottom light indicates the pressure switch. In normal operation, all 3 lights will be blinking ON and OFF in proportion to the feed control setting (see “Heater Operation”). Should any problem arise in the feed system, some or all of the lights will either go out or be blinking BRIGHT - DIM. Should this occur, please refer to the “Troubleshooting” section.

1.6 Auger Cycle Timer

In conjunction with the feed control, the auger cycle timer controls the feed rate. This is achieved by turning the auger motor on and off. Failure of this component will result in a troubleshooting light change. See “Troubleshooting” section for more details.

1.7 High Temperature Manual Reset Thermal Disk

The manual reset thermal disk is a high temperature safety switch. If the heater should reach an unusually high temperature (due to overheating caused by power outage or circulation fan failure), this switch will shut the feed system off. The exhaust and circulation fans will continue removing heat until the unit is at room temperature.

Once this switch has been tripped, the control system will not allow any more fuel to feed into the burn pot until it has been manually reset. **DO NOT RESET THIS UNIT UNTIL THE CAUSE HAS BEEN FOUND AND REPAIRED.** Failure of this component will result in a status light change. See “Troubleshooting” section for more details.

1.8 Pressure Switch.

The pressure switch is a safety device that senses whether or not the exhaust fan is functioning properly. Failure of this component will also result in a status light change. See “Troubleshooting” section for more details

2. Heater Operation

In order to use your stove, you should be familiar with the 4 controls of your heater: Fan Speed, Feed Rate, Damper and Start button. These 4 controls will allow you to adjust and operate your stove safely and efficiently. The location and method of adjustment for each of these is described below.

2.1 Circulation Fan Speed Control

The fan speed control is located on the top center of the control panel (see diagram). Turning this knob counter-clockwise temporarily turns the circulation fan off. Rotating clockwise decreases the speed of the circulation fan from High to Low. It is **NOT** recommended to leave this knob in the OFF position. When left in the OFF position, the heater becomes over heated and the control circuit automatically overrides this switch and puts the circulation fan on high speed.

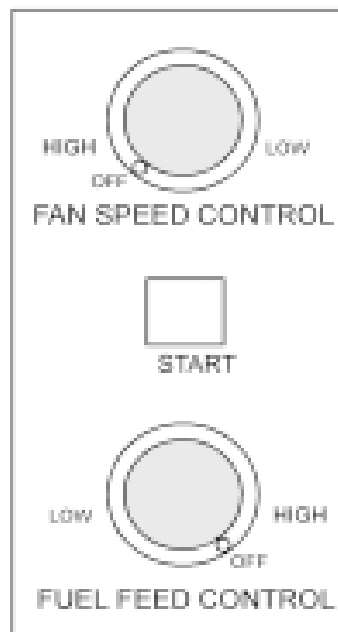

2.2 Feed Control Knob

The feed control is a round knob located at the bottom of the control panel (see diagram). Turning the knob in the counter-clockwise direction will turn the feed off. As the knob is turned clockwise, the feed rate into the burn pot is increased, resulting in a bigger fire.

2.3 Damper Control

The damper control rod is located on the left side of the stove. This rod controls the amount of air passing through the burn pot. By pushing the control rod in, you reduce the amount of air passing through the burn pot. By pulling the rod out, you will increase the amount of air passing through the burn pot.

2.4 Start Button

The start button is located in the middle of the control panel (see diagram). Pushing the start button is the first step in starting the heater. The heater will now run in manual operation mode for 15 minutes. The heater will switch to the automatic mode only if the heater reaches a preset temperature. If this temperature is not reached within 15 minutes the unit will shut off. To allow the unit to run for another 15 minutes, simply press the start button again.

2.5 Starting your Heater for the First Time

Once your heater is properly installed, complete the following steps to light it for the first time:

1. Fill the hopper with pellet fuel.
2. Turn the feed control knob clockwise to high.
3. Press the start button. The exhaust and circulation fan should come on and all 3 status lights should begin to blink.
4. Monitor the burn pot (located inside the burn chamber, see “Stove Cross Section” diagram for exact location.). Once pellet fuel begins to drop into the burn pot, turn the feed control knob to OFF, (counter clockwise until it “clicks”) and allow the unit to stop running. Do not light the pellet fuel at this time. If the unit stops and no fuel has been fed into the burn pot, repeat steps 1 through 4.

You are now ready to light the stove for the first time.

2.6 Starting (lighting) your Heater

To start your heater, complete the follow steps:

1. Ensure there is adequate fuel in the hopper.
2. Turn the fuel feed knob to desired setting. (If in doubt, adjust to 12 o'clock setting)
3. Adjust damper to approximate setting. (If in doubt, pull open to approximately 3/4" - 2 cm)
4. If equipped with electric start, proceed to step 9.
5. Open the burn chamber door and place a handful of fuel in the burn pot. The burn pot should be approximately 1/4 full with wood pellets.
6. Pour lighter gel on pellets in the burn pot.
7. Ignite lighter gel with barbecue lighter and allow the pellets to catch fire. **DO NOT ATTEMPT TO IGNITE HOPPER FUEL ON FIRE.**
8. Close the combustion chamber door.
9. Press the start button. The following should happen :
 - a. The exhaust fan will start.
 - b. The circulation fan will start at the fan speed control setting.

- c. The feed system begins to feed. The auger and troubleshooting lights should begin to blink.
 - d. If electric start is installed, it will come on.
 - e. On electric start models, the flame should appear within 5 to 10 minutes.
10. Allow the flame to stabilize for 15 minutes.
 11. Adjust the feed and damper as necessary. (see “Adjusting your Heater” section)
 12. If the unit shuts off and there is still a flame, press the start button again.

2.7 Stopping your Heater

To stop your heater, turn the fuel feed control knob counter-clockwise to the OFF position. This will cause the feed system to stop (troubleshooting lights will stop blinking) and the flame should die out within 5 minutes. The exhaust fan and circulation fan will continue to run until your heater is cold (approximately 30 minutes). DO NOT turn off electrical power to stop the heater, as this will result in your unit overheating.

2.8 Adjusting your Heater

The Heater will not operate properly if either the ash door or glass door is not properly closed OR if the wrong size of venting is used. It is equally important that you use good quality, wood pellet fuel. A poor quality fuel will create poor and unsatisfactory operating conditions.

To increase the heat output of your stove, slightly increase the feed rate by turning the feed control knob clockwise. In a few minutes the flame size will increase. If the flames are darkish with black tips, open the exhaust damper slightly and allow the flame to stabilize. Repeat the procedure if more heat is desired. Flames that are too large mean the feed rate is too high for the amount of combustion air present. Reduce the feed rate slightly or increase the amount of combustion air. In a few minutes the size of the flame will reduce. If the size of the flame is fluctuating between feed drops, this indicates that the amount of combustion air is too much for the amount of feed. In this case, close the air damper slightly and once again, allow the flame to stabilize. When reducing heat output, slightly close the air damper at the same time as you are reducing the feed rate. If the air damper is open too far, there is a chance of extinguishing the fire. Some fuels have a tendency to leave ash and clinker deposits in the bottom of the burn pot. Use a poker to remove the clinkers if the heater is operating OR cool off the heater and clean the burn pot.

If you find that the circulation fan is constantly running on high although your fan speed setting is much lower, your unit is overheating. Reduce the feed rate as described above.

III. Maintenance

During operation, your heater produces a lot of “FLY” ash. The ash will deposit inside the heaters’ air passages and must be removed on a regular basis. A medium size brush is ideal for this purpose. Make sure the heater is cool and there are no embers present in the burn pot, ashtray or combustion chamber. Also, make sure there is no power to the unit by unplugging the power cord from the power source. Your heater can then be cleaned in the following manner:

1. Pull and push the cleaning rod, which is located in the center, above the door. This will remove the ash deposits on the heat exchanger tubes. The removed ash will fall on the top heat shield, located in the burn chamber.
2. Lift the top heat shield and remove it carefully as there may be a significant amount of ash on it. Dump the ashes into the burn chamber.
3. Brush the top heat shield clean and remove it from the heater.
4. Remove the burn pot and burn pot stand and clean them thoroughly.
5. Using a brush, clean the walls and floor of the burn chamber. Dump all of the ash into the ashtray. Remove the ashtray and dispose off the ashes in safe manner. If ashes are stored in a container, make sure the lid is secure. DO NOT place the container on combustible surfaces.
6. Once a year, at the start of the heating season, clean the heater and all of the venting pipes. Check for any blockage in the intake and exhaust pipes.
7. Replace burn pot stand, burn pot and top heat shield to their original positions.
8. Clean the glass with a mild glass cleaner.
9. Inspect condition of the door gasket periodically and replace as necessary.
10. Open the right hand side panel and oil the circulation fan motor bearings. Use a light oil such as sewing machine oil. The 2 oil ports are located on the top of the motor, one near the end and one near the fan housing. There may be a rubber plug in one or both of these oil ports. This plug must be removed prior to oiling.

IV. Trouble Shooting Guide

The KOZ I model 100 is equipped with a troubleshooting light module, located at the back, bottom right hand corner of the stove. This module consists of a set of three red lights. Under normal working conditions, while the stove is operating, all three lights are BLINKING (on and off). The rate of blinking is in proportion to the fuel feed rate. The higher the feed rate, the faster the lights will blink. Any time the sensors detect abnormal working conditions, they will turn OFF the fuel feed system to prevent any further damage and turn OFF or PULSE (bright - dim) the lights to indicate where the fault has occurred.

PROBLEM	LIGHT STATUS	POSSIBLE CAUSES	RELEVANT SECTION OR REQUIRED ACTION
No Fuel Feed/ Unit won't start.	Top Light Blinking Middle Light Blinking Bottom Light Blinking	1. Auger jammed.	1. Move auger motor back and forth to free jam.
		2. Auger motor failed.	2. Replace auger motor.
		3. Auger slipping.	3. Tighten auger bolt.
		4. No pellet fuel.	4. Add fuel to the hopper.
	Top Light Pulsing Middle Light Pulsing Bottom Light Off	1. Pressure switch failure.	1. Replace pressure switch.
		2. Pressure switch tube broken or loose.	2. Replace pressure switch tube.
		3. Exhaust vents plugged.	3. Clean exhaust venting and pressure port.
		4. Exhaust fan failure.	4. Replace exhaust fan.
	Top Light Pulsing Middle Light Off Bottom Light Off	1. Manual reset thermal disk has tripped.	1. See "Manual Reset Thermal Disk" section under "Component Description".
		2. Manual reset thermal disk failure.	2. Replace manual reset thermal disk.
	Top Light Off Middle Light Off Bottom Light Off	1. No power to the unit.	1. Verify that unit is plugged into a powered 120 volt electrical outlet.
		2. Auger cycle timer failed.	2. Replace auger cycle timer.
3. Start button defective.		3. Replace push button start.	
4. Feed control failed.		4. Replace feed control.	
Stove won't turn OFF.	N/A	1. Stove in "Cool Down". 2. Defective auto thermal disk. 3. Control 15 minute timer.	1. Allow sufficient cool down time. 2. Replace auto thermal disk. 3. Replace timer.
Stove won't light.	Top Light Blinking Middle Light Blinking Bottom Light Blinking	1. No pellet fuel. 2. Igniter failure. 3. Circulation fan failure.	1. Add pellet fuel to hopper. 2. Replace igniter fuse and igniter. 3. Adjust or replace circulation fan.
Stove not operating properly. Damper adjustment does not affect the burn rate. Lazy flame. Fuel piles up in burn pot.	N/A	1. Burn pot dirty.	1. Clean burn pot. See "Component Description" as well as "Maintenance" sections.
	N/A	1. Not enough air. 2. Too much fuel. 3. Poor quality and non standard fuel.	1. Adjust air damper. 2. Reduce feed rate. 3. Change fuel supplier.
Short flame on high feed.	N/A	1. Poor quality fuel. 2. Too much air. 3. Heat exchange requires cleaning.	1. Change fuel supplier. 2. Reduce air damper. 3. Clean heat exchanger. See "Maintenance" section.
Too large and dark orange flame.	N/A	1. Not enough air. 2. Too much fuel. 3. Poor quality and non standard fuel.	1. Not enough air. 2. Too much fuel. 3. Poor quality and non standard fuel.
Not enough Heat output.	N/A	1. Too much air. 2. Feed rate set too low.	1. Reduce air damper. 2. Increase feed rate.
Flames go out on low feed.	N/A	1. Too much air. 2. Feed rate set too low.	1. Reduce air damper. 2. Increase feed rate.
Smell of smoke in room.	N/A	1. Joints in vent pipe not sealed properly.	1. Seal venting system with high temperature RTV silicone sealant.
Circulation fan always runs on high.	N/A	1. Unit is overheating.	1. Reduce the feed rate.

Note: For safety, contact a qualified serviceman for all repair work.

V. Diagrams and Parts List

1. KOZI 100 Circuit Diagram

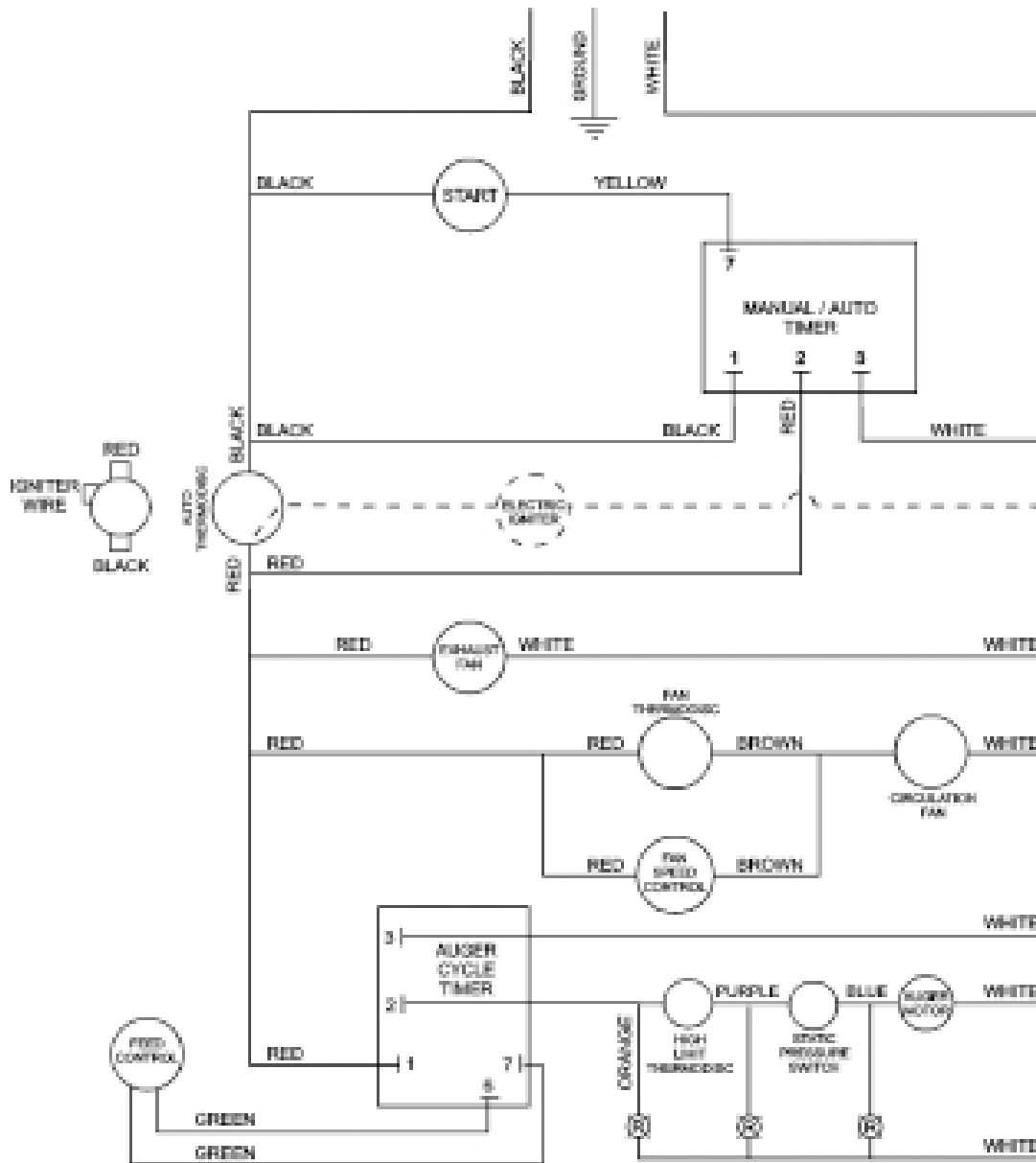

3. Equipment Compartment

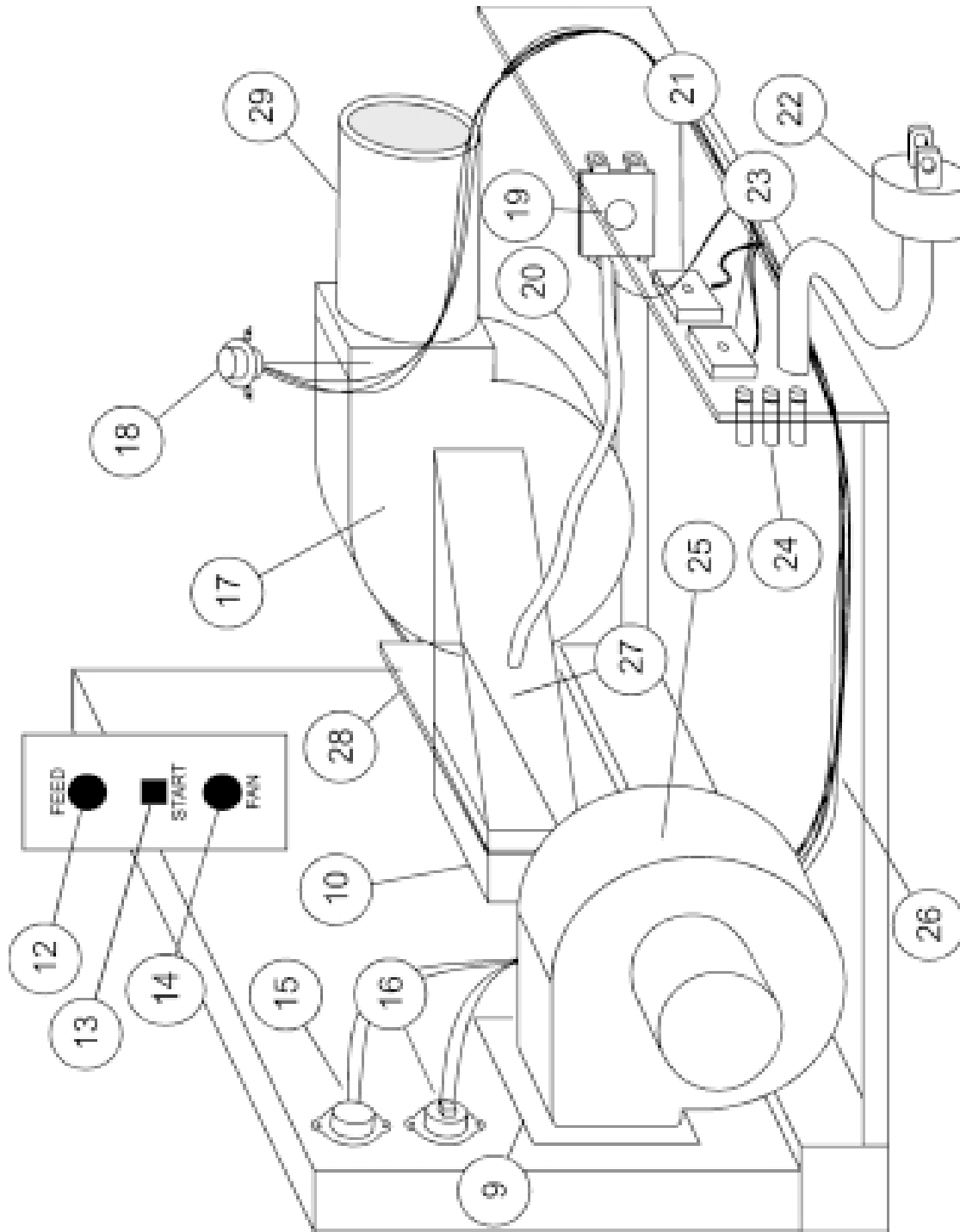

4. Parts List

Item No.	Description	Part No.
Panels & Trims		
1	Pedestal Base Assembly (Black)	10009
Not Shown	Gold, Side Trims	10027
2	Front Grill	10010
3	Top Lid (Black)	10022
4	Hopper Lid (Black)	10023
5	Back Cover Plate (Black)	10021XL
6	Top Heat shield –Burn Chamber	10011XL
7	Back Heat Shield – Burn Chamber	10012XL
Not Shown	Right Heat Shield – Burn Chamber	10013-1XL
Not Shown	Left Heat Shield - Burn Chamber	10013-2XL
Not Shown	Right Side Panel (Black)	10020
Not Shown	Left Side Panel (Black)	10019XL
Gaskets & Gasket Kits		
8	Auger Chute Gasket Kit	10006-12
9	Circulation Fan Gasket	10036-1
10	Exhaust Housing Mounting Gasket	10002XL
Not Shown	Exhaust Fan Mounting Gasket	10002-1XL
Not Shown	Exhaust Fan Motor Mounting Gasket	10031-1
Not Shown	Door Rope Gasket	10025-2
Not Shown	Ash Tray Rope Gasket	10017-3
Electrical Components		
11	Auger Motor	10035
12	Feed Control Switch	10044
13	Push Button Start	10043
14	Circulation Fan Speed Control	10038
15	Circulation Fan Override, Thermal disk	10037
16	Manual Reset, Overheat Thermal disk	10039
17	Exhaust Fan	10031
18	Exhaust Temperature Thermal disk.	10034XL
19	Static Pressure Switch	10032
20	Static Pressure Switch Tube	10033XL
21	Auto/Manual Timer	10041
22	Electrical Cord	10042
23	Auger Cycle Timer	10040
24	Trouble Shooting Module Light	10046
25	Circulation Fan	10036
26	Wiring Harness	10045XL
Kits, Assemblies & Other Components		
27	Exhaust Housing Box	10002XL
28	Damper Kit (Includes Damper, Coil Handle, Slide Bracket, Rubber Slider)	10004XL
29	Exhaust Tube Assembly	10026
30	Cleaning Rod (Includes Coil Handle)	BV22
31	Complete Door Assembly (Black)	10025
31	Complete Door Assembly (Gold)	10025
Not Shown	Door Handle Kit	10025-4
32	Door Glass	10025-5
33	Ash Tray	10017XL
Not Shown	Ash Tray Knob	10017-2XL
34	Glass Holder Kit	10025-3
35	Burner Pot	10016XL
36	Burner Pot Stand	10014XL
37	Auger Rebuild Kit (Includes bushings, auger, auger holder, auger holder gasket, nut and bolt...)	10006-7, 10008, 10008-4, 10035-1
38	Complete Hopper/Auger Assembly	10006
Not Shown	Pedestal Gold Molding	10009-3
Not Shown	KOZI Logo	10009-4

5. Accessories List

Item No.	Description	Part No.
Optional Equipment		
39	Igniter Replacement Kit	N/A
39	Igniter Replacement Kit	N/A
Not Shown	Air Intake Kit	AK100
Not Shown	Air Intake Check Valve	CV100
Not Shown	Hopper Extension	HE2
Not Shown	Insert Loading Chute	LC100

VI. WARRANTY

APR Industries Ltd. honors a five-year limited warranty on all steel fabricated parts and a one-year warranty on all electrical parts. The following items are not covered under warranty.

1. Glass.
2. Gasket and Seals.
3. Ceramic Bricks.
4. Burner Pot.
5. Paint and Powder Coating.
6. Gold Plating.
7. Inner Heat Shields.
8. Gear Motor.
9. Self-Igniter.
10. Glass Saver™

Contact Your Dealer for Warranty Information.

The limited warranty covers defects in the material and poor workmanship as long as the heater has been installed in accordance to the instruction manual. Warranty is void if the heater is misused. It is APR Industries Ltd.'s option whether to repair or replace the parts. The customer pays all shipping costs to and from the factory.



WWW.KOZISTOVES.COM