

Owners Manual for Kamado Joe Kettle Joe

PDF provided by [Stove & Grill Parts For Less](#)

KETTLE JOE™ OWNER'S MANUAL
KJ15040320, KJ15043321

A GUIDE TO KAMADO COOKING



Manual Code: 9804190015 | 220318-GH

Table of Contents

Warnings	2
Parts List & Tools Required	6
Grill Set-Up Instructions	7
Assembly Instructions	8
Hinge Adjustment	8
Cleaning and Care	16
Quick Start Guide	16
Zone Cooking	17

Grill does not come with charcoal.

WARNING

- This manual contains important information necessary for the proper assembly and safe use of the appliance.
- Read and follow all warnings and instructions before assembling and using the appliance.
- Keep this manual for future reference.

 **Failure to follow these instructions could result in fire, explosion or burn hazard which could cause property damage, personal injury or death.**

CARBON MONOXIDE HAZARD

- Burning charcoal or wood chips gives off carbon monoxide, which has no odor and can cause death.
- Use only outdoors where it is well ventilated.

⚠️ WARNINGS AND IMPORTANT SAFEGUARDS

READ ALL INSTRUCTIONS

- **WARNING!** This grill will become very hot. Do not move it during operation.
- **WARNING!** Do not use indoors!
- **WARNING!** Do not use spirit or petrol for lighting or re-lighting! Use only firefighters complying to EN 1860-3!
- **WARNING!** Keep children and pets away from grill at all times. Do NOT allow children to use grill. Close supervision is necessary when children or pets are in the area where grill is being used.

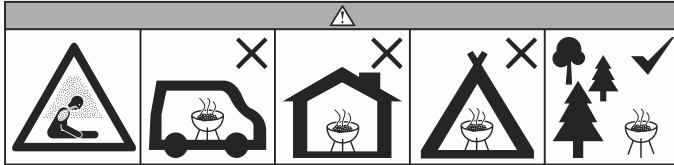

• A MAJOR CAUSE OF FIRES IS FAILURE TO MAINTAIN REQUIRED CLEARANCES (AIR SPACES) TO COMBUSTIBLE MATERIALS. IT IS OF UTMOST IMPORTANCE THAT THIS PRODUCT BE INSTALLED ONLY IN ACCORDANCE WITH THESE INSTRUCTIONS.

- Do not use the grill in a confined and/or habitable space e.g. houses, tents, caravans, motor homes, boats. Danger of carbon monoxide poisoning fatality.
- Always use grill in accordance with all applicable local, state and federal fire codes.
- Before each use check all nuts, screws and bolts to make sure they are tight and secure.
- Never operate grill under overhead construction such as roof coverings, carports, awnings or overhangs.
- Grill is for **OUTDOOR USE ONLY**.
- Keep a minimum 10 ft. (304.8CM) clearance of all combustible materials such as wood, dry plants, grass, brush, paper or canvas.

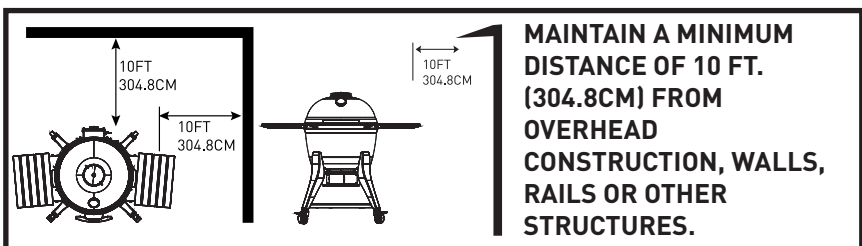

WARNINGS AND IMPORTANT SAFEGUARDS

- Never use grill for anything other than its intended use. This grill is NOT for commercial use.
- Use of alcohol, prescription or non-prescription drugs may impair user's ability to assemble or safely operate grill.
- Keep a fire extinguisher accessible at all times while operating grill.
- When cooking with oil or grease, have a type BC or ABC fire extinguisher readily available.
- In the event of an oil or grease fire do not attempt to extinguish with water. Immediately call the fire department. A type BC or ABC fire extinguisher may, in some circumstances, contain the fire.
- Use grill on a level, non-combustible, stable surface such as dirt, concrete, brick or rock. An asphalt surface (blacktop) may not be acceptable for this purpose.
- Grill **MUST** be on the ground. Do not place grill on tables or counters. Do NOT move grill across uneven surfaces.
- Do not use grill on wooden or flammable surfaces.
- Keep grill clear and free from combustible materials such as gasoline and other flammable vapors and liquids.
- Do not leave grill unattended.
- Do NOT allow anyone to conduct activities around grill during or following its use until it has cooled.
- Never use glass, plastic or ceramic cookware in grill. Never place empty cookware in grill while in use.
- Never move grill while in use. Allow grill to cool completely (below 115°F (45°C)) before moving or storing.
- Do not store grill with hot ashes or charcoal inside grill. Store only when fire is completely out and all surfaces are cold.
- Never use grill as a heater. **READ CARBON MONOXIDE HAZARD.**
- The grill is **HOT** while in use and will remain **HOT** for a period of time afterwards and during cooling process. Use **CAUTION**. Wear protective gloves/mitts.
- **DO NOT** bump or impact the grill to prevent personal harm, damage to grill or spillage/splashing of hot cooking liquid.

WARNINGS AND IMPORTANT SAFEGUARDS

- Be careful when removing food from grill. All surfaces are HOT and may cause burns. Use protective gloves/mitts or long, sturdy cooking tools for protection from hot surfaces or splatter from cooking liquids.
- Do not touch HOT surfaces.
- Grill is HOT during use. To avoid burns, keep face and body away from vents and when opening lid. Steam and hot air are expelled during use.
- When cooking above 350°F (175°C), carefully open the grill (or burp the grill) each time you lift the grill dome to prevent flashback – a surge of white-hot heat caused by a rush of oxygen. Partially opening the lid 2-3 inches (5-8cm) and allowing heat to escape for about 5 seconds should prevent this.
- Air dampers are HOT while the grill is in use and during cooling. Wear protective gloves when adjusting.
- Grill has an open flame. Keep hands, hair and face away from flame. Do NOT lean over grill when lighting. Loose hair and clothing may catch fire.
- DO NOT obstruct flow of combustion and ventilation.
- Do not cover cooking racks with metal foil. This will trap heat and may cause damage to the grill.
- Never leave HOT coals or ashes unattended.
- Fuel should be kept red hot for at least 30 minutes prior to use.
- Do not cook before the fuel has a coating of ash.
- Do not remove ash drawer while ashes and charcoal are HOT.
- Use protective gloves when handling this grill or working with fire. Use protective gloves or long, sturdy tools when adding wood or charcoal.
- The maximum amount of charcoal for the Kettle Joe is 6 lbs. (2.7 kg). Never overfill charcoal grate. This can cause serious injury as well as damage to the grill.
- Dispose of cold ashes by placing them in aluminum foil, soaking with water and discarding in a non-combustible container.
- SloRoller should not be used for temperatures over 500°F (260°C)

SAVE THESE INSTRUCTIONS

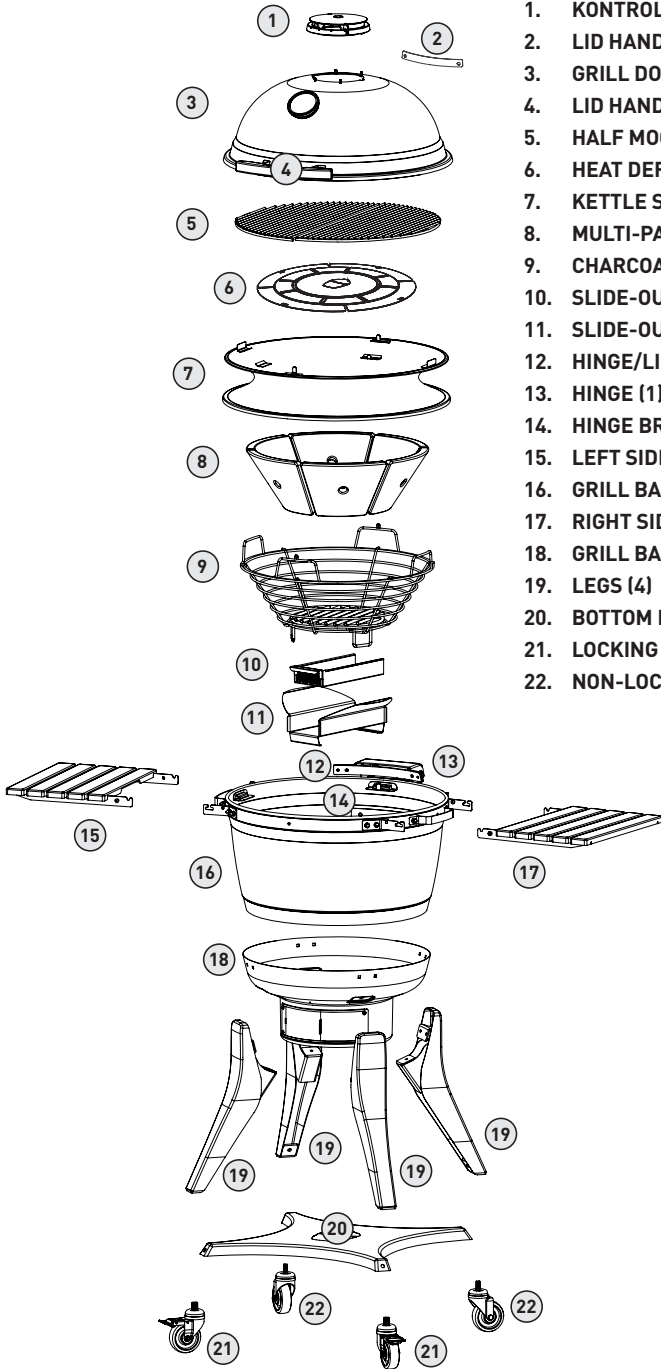

1. KONTROL TOWER™ TOP VENT (1)
2. LID HANDLE BRACKET (1)
3. GRILL DOME (1)
4. LID HANDLE (1)
5. HALF MOON COOKING GRATES (2)
6. HEAT DEFLECTOR (1)
7. KETTLE SLÖROLLER™ (1)
8. MULTI-PANEL™ CERAMIC FIREBOX (6)
9. CHARCOAL BASKET (1)
10. SLIDE-OUT™ ASH DRAWER (1)
11. SLIDE-OUT ASH DRAWER BASE (1)
12. HINGE/LID BRACKET (1)
13. HINGE (1)
14. HINGE BRACKET (1)
15. LEFT SIDE SHELF (1)
16. GRILL BASE (1)
17. RIGHT SIDE SHELF (1)
18. GRILL BASE BOTTOM (1)
19. LEGS (4)
20. BOTTOM PLATE (1)
21. LOCKING SWIVEL CASTERS (2)
22. NON-LOCKING SWIVEL CASTERS (2)

Grill Set-Up

UNBOXING YOUR GRILL

Open the dome of the grill and remove the components from the inside of the grill. Handle the internal ceramic parts with care.

KETTLE JOE

1 Once the internal components of the grill have been removed, lift the grill out of the container and set it aside. Due to the weight of this grill, we highly recommend two people perform this task. Do NOT lift the grill by the side shelf tabs. Use the rear hinge and the front lower vent opening as lifting points.

Hardware

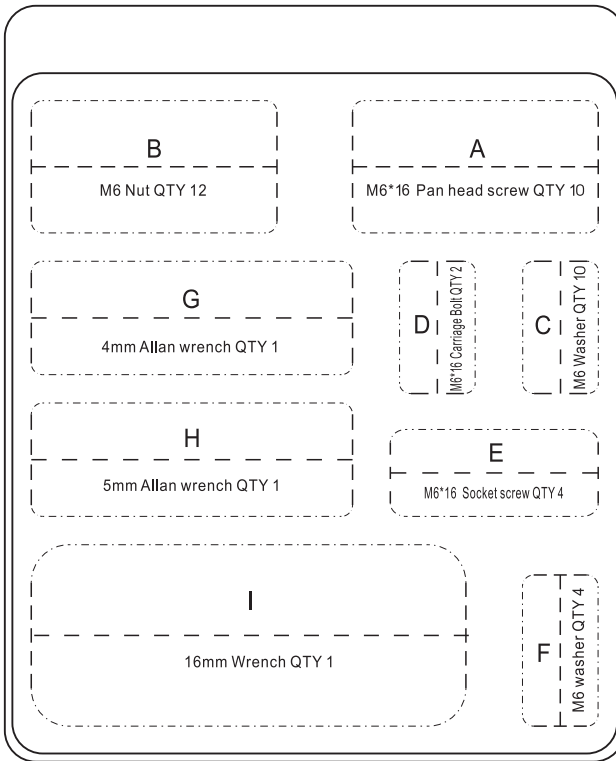

Kettle Joe Hinge Adjustments

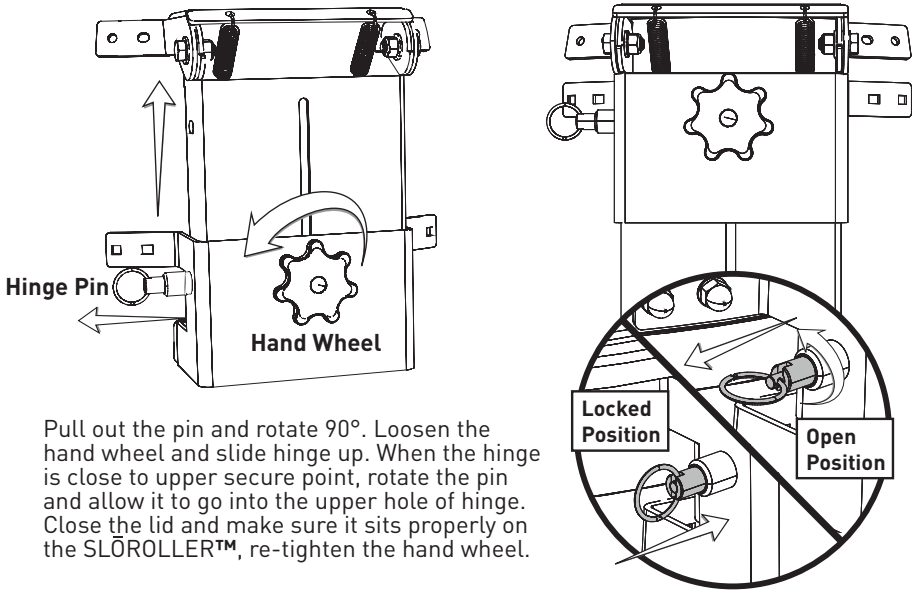

Pull out the pin and rotate 90°. Loosen the hand wheel and slide hinge up. When the hinge is close to upper secure point, rotate the pin and allow it to go into the upper hole of hinge. Close the lid and make sure it sits properly on the SLÖROLLER™, re-tighten the hand wheel.

1

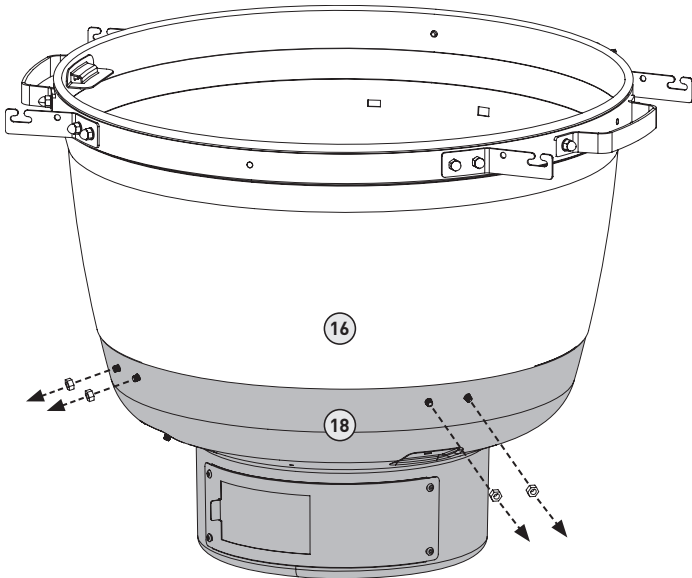

**Remove 8 nuts from the base (no need for further use).
Keep screws metal washers and mica gaskets for steps 2 and 3.**

2

A

M6X16
X2



C

φ6
X2



PRE-ASSEMBLED



M6X20
X4

WASHER
X4



GASKET
X4



4mm

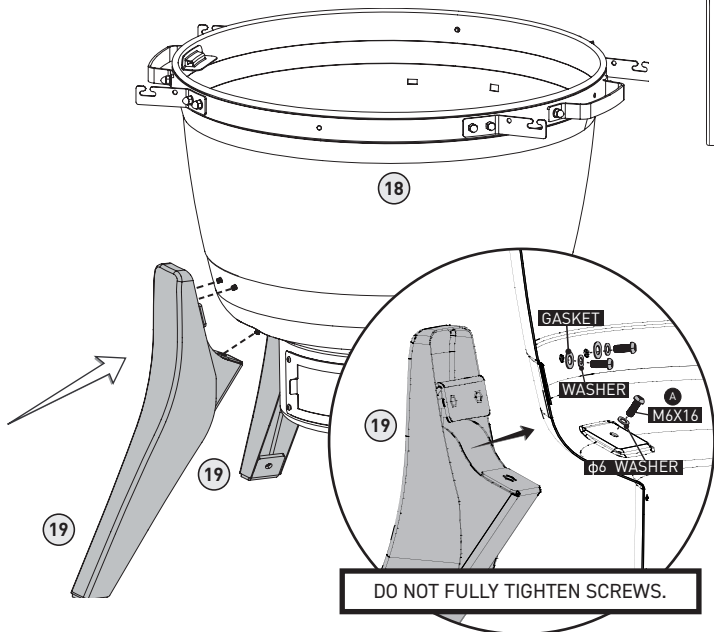
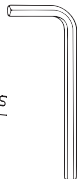

3

A

M6X16
X2



C

φ6
X2



PRE-ASSEMBLED



M6X20
X4

WASHER
X4



GASKET
X4



4mm

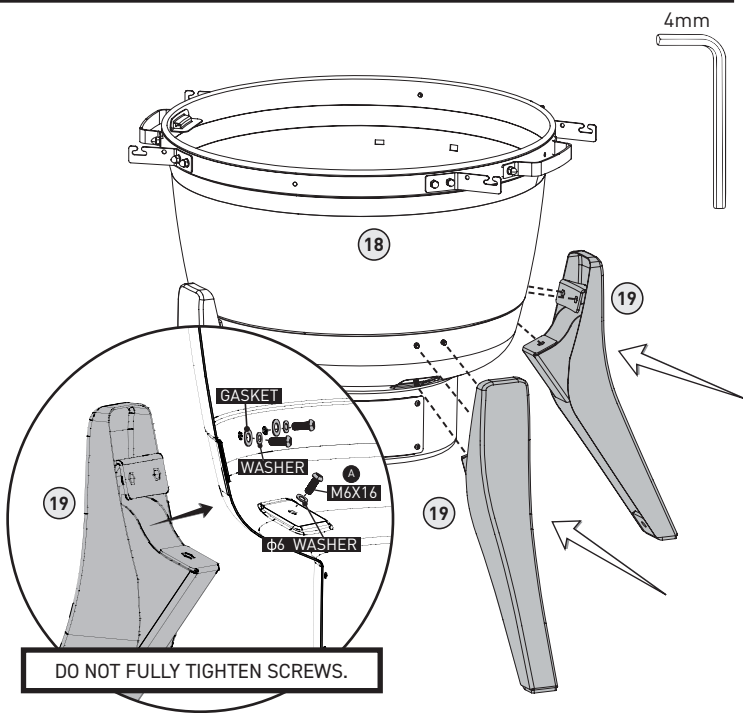

4

E
M6X16
X4



F
φ6
X4

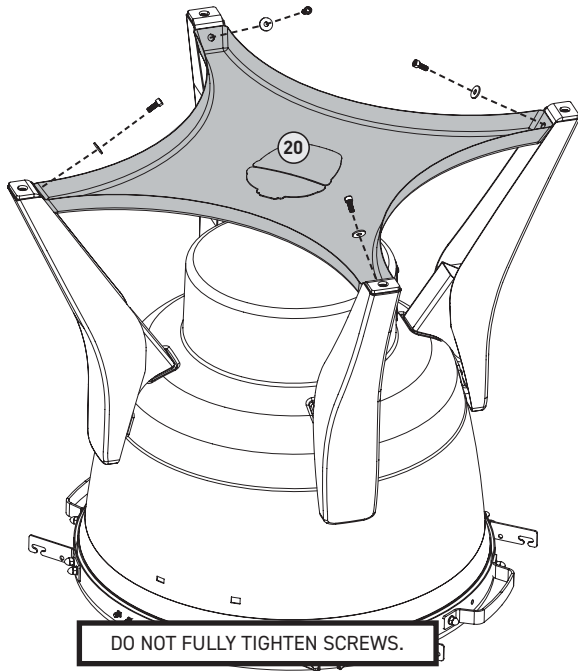

5

I
16mm
Wrench
X1

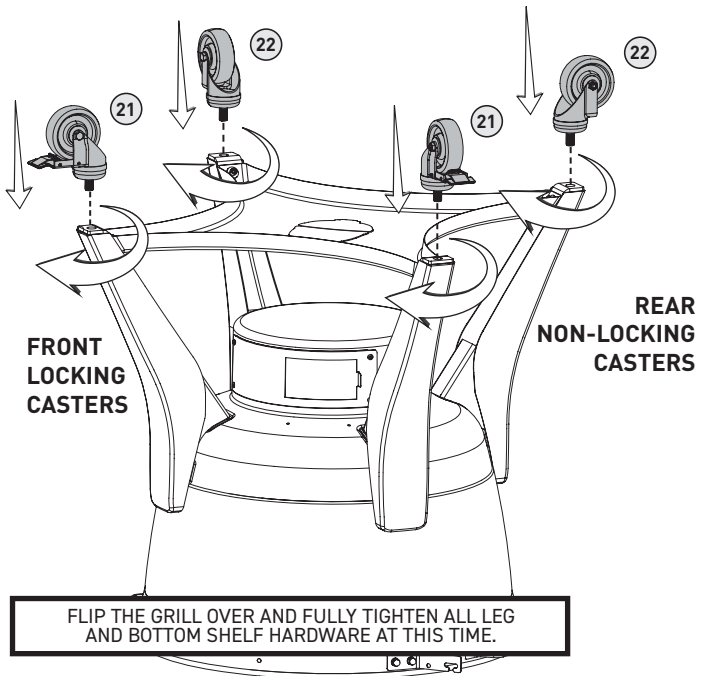
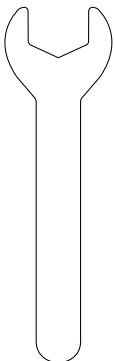

6

A
M6X16
X2



B
M6
X2



C
 $\phi 6$
X2

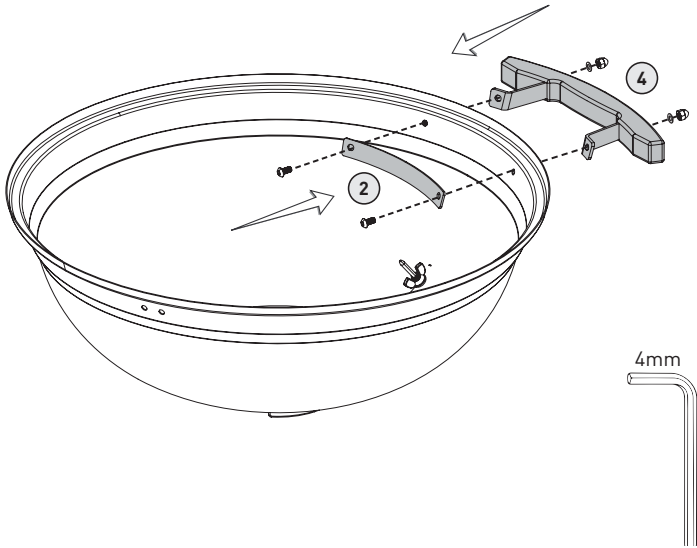

7

A
M6X16
X4



B
M6
X4

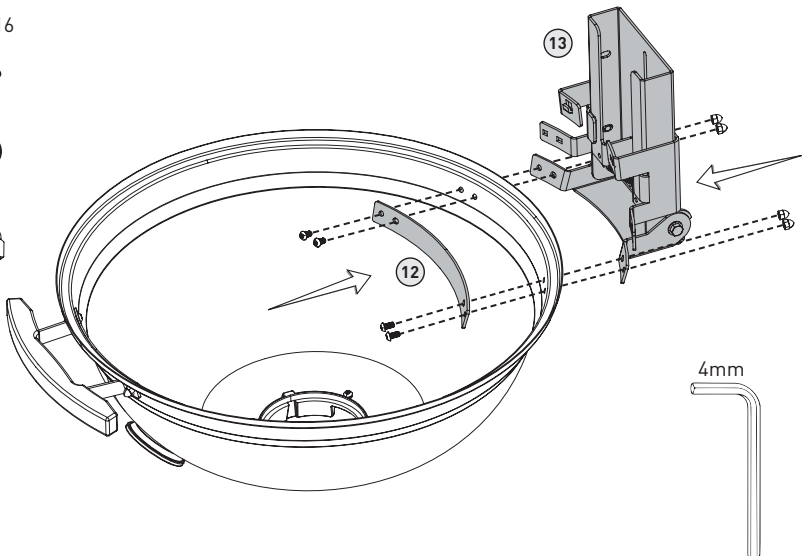

8

B

M6
X4



C

Φ6
X4

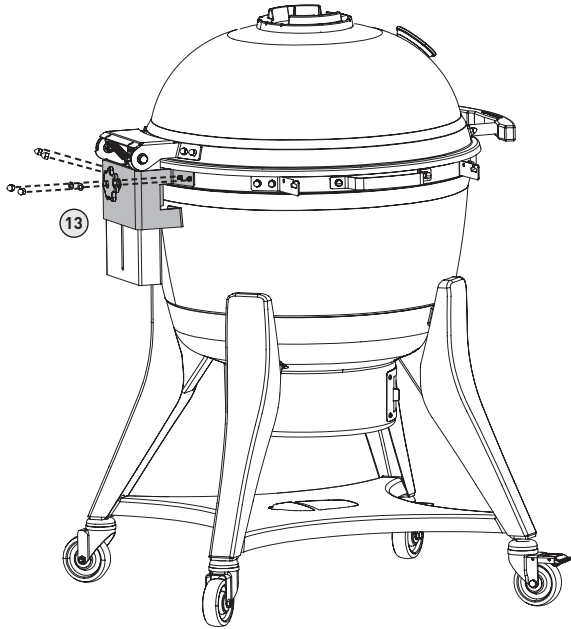

9

D

M6X16
X2



B

M6
X2

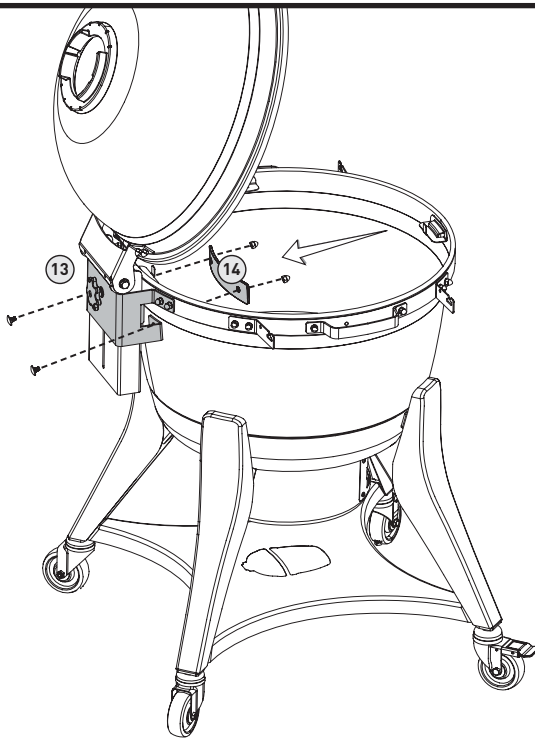

10

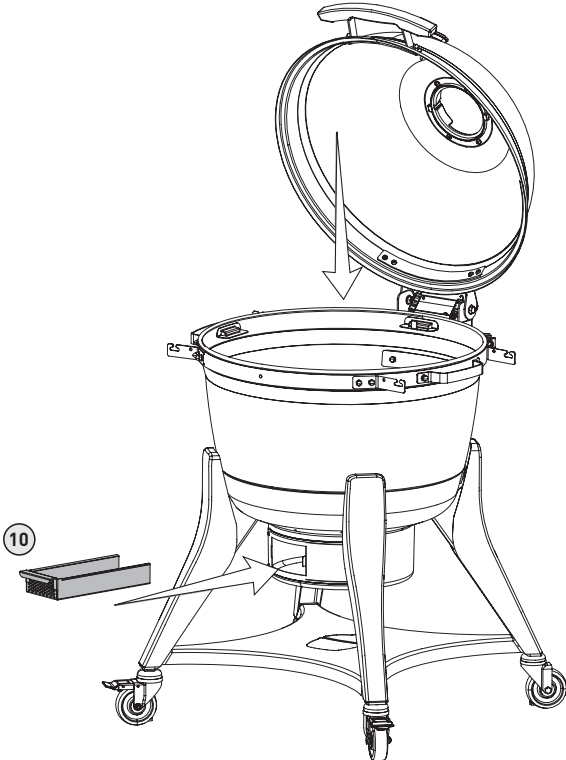
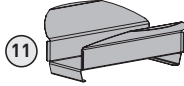
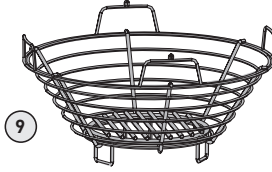
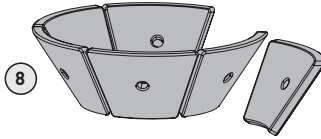

11

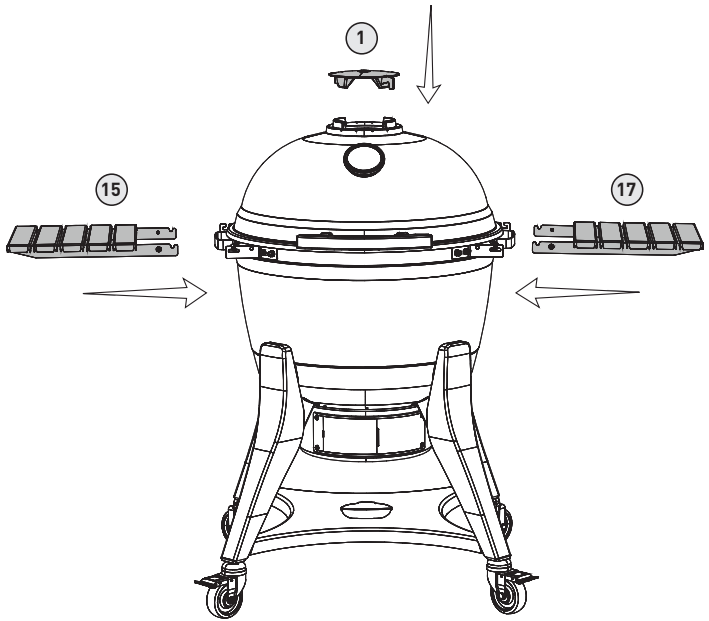

12

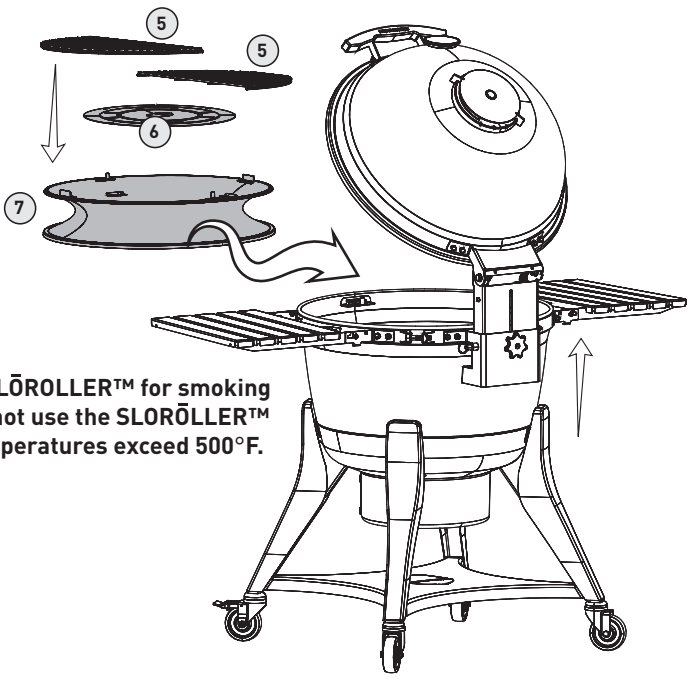

Use the SLÖROLLER™ for smoking only. Do not use the SLÖROLLER™ when temperatures exceed 500°F.

Loosen the hand wheel and pull the hinge pin to adjust the hinge height. Insert the SLÖROLLER™, Heat Deflector, and Cooking Grates.

13



Without SIÖROLLER™



With SIÖROLLER™

Cleaning & Care

Your Kamado Joe grill is made of quality materials, so general care and maintenance is minimal. The best way to protect your Kamado Joe from the elements is with a grill cover.

SELF-CLEANING

- 1 Add charcoal and light it.
- 2 Install the cooking grates.
- 3 Open the top and bottom air vents fully and let the temperature inside the grill rise to 500°F (260°C) with the dome closed.
- 4 Hold the temperature at around 500°F (260°C) for 15-20 minutes.
- 5 Close the bottom vent fully and wait another 15-20 minutes to close the top vent.

This process will burn off any unwanted residue from the inside of your grill. Before cooking again, brush the cooking grate with a standard grill brush. Use a soft bristle brush on the ceramics to remove any residue.

Once or twice a year, you should do a more thorough cleaning of the inside of the grill. Remove the internal components and remove any residual ash or debris that has collected between the grill body and the internal components. Use a plastic bristle brush to clean the inside ceramic surface and scoop or vacuum debris from the bottom of the grill before replacing the internal components.

Quick Start Guide

STARTING IT UP

- 1 Add charcoal to firebox and light using one or two fire starters.
- 2 Leave dome open for 10 minutes with the bottom vent fully open.
- 3 Close the dome.
- 4 Begin closing the top vent and bottom vent when the dome temperature is within 50°F (10°C) of your target.

MAINTAINING TEMPERATURE

To lower the temperature, decrease the airflow through the grill by closing the vents. Conversely, raise the temperature by opening the vents. Adjustments to the vents are not immediate—allow 10–15 minutes for a vent change to take effect. Because your ceramic Kamado Joe retains heat so well, it can take some time to fully heat. Give your grill 20–40 minutes to stabilize the temp before you start cooking.

COOLING IT DOWN

- 1 When finished cooking, close the bottom vent completely.
- 2 Once the temperature falls below 400°F (205°C), close the top vent almost completely, but leave a small crack.
- 3 Do not cover the grill until the dome is cool to the touch.

TO LOWER THE TEMPERATURE, CLOSE THE VENTS.

TO RAISE THE TEMPERATURE, OPEN THE VENTS.

ZONE COOKING

3 different cooking zones.

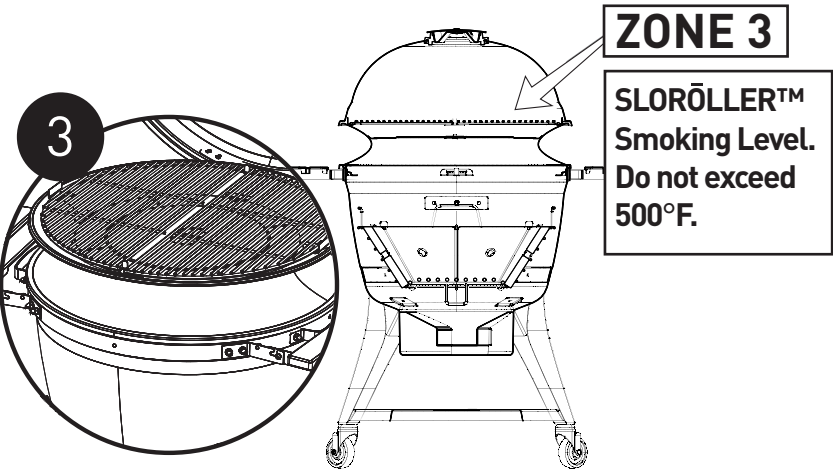
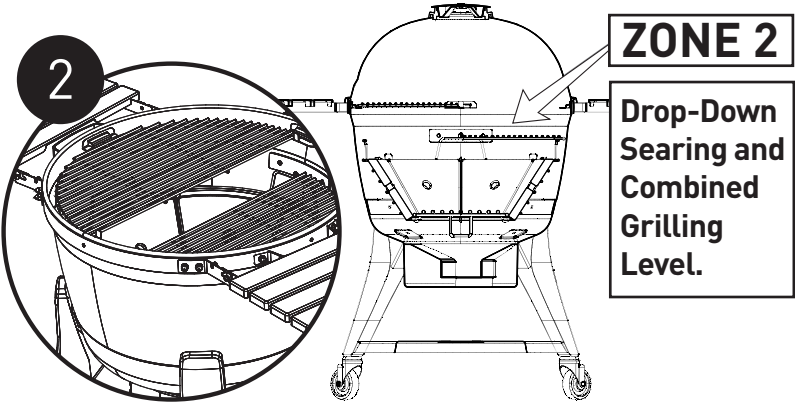
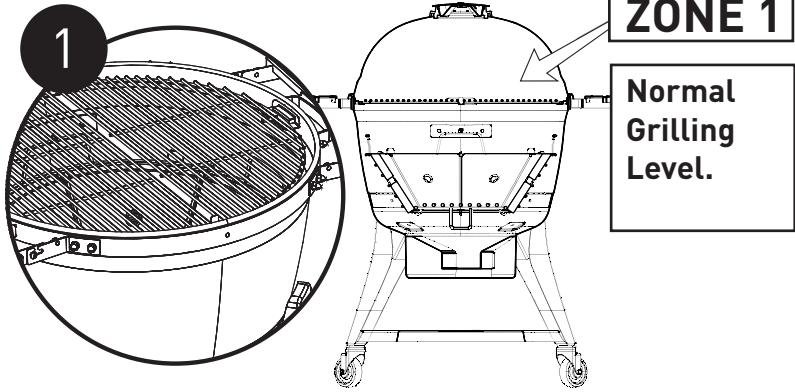

QUICK TEMPERATURE GUIDE

Approximate temperatures for cooking techniques.

GRILLING	400–600°F (205–315°C)
SEARING	500–750°F (260–400°C)
BAKING	300–750°F (150–400°C)
ROASTING	300–450°F (150–230°C)
SMOKING	225–275°F (105–135°C)

CAUTION

BURP

When cooking above 350°F (175°C), carefully open the grill (or burp the grill) each time you lift the grill dome to prevent flashback.

LIQUIDS

Do not spill liquids inside or on the grill while it is hot.

SPARKS

Be aware of sparks and embers when using the grill on a wooden deck.

DURING OPERATION

Do not leave your grill unattended with the grill dome open.

KAMADOJOE®

[KAMADOJOE.COM](https://www.kamadojoe.com)

[KAMADOJOE.COM/CONTACT](https://www.kamadojoe.com/contact)

[KAMADOJOE.COM/WARRANTY](https://www.kamadojoe.com/warranty)

[KAMADOJOE.COM/COLLECTIONS/PARTS](https://www.kamadojoe.com/collections/parts)