



INSTALLATION AND OPERATION MANUAL

Free-Standing Pellet Stove

Save These Instructions
For Future Reference

P/N 900081-00, REV. A, 05/2015



P900081-00



**Pellet Stove
Model Bella™**



Report No. 14-196

A French manual is available upon request. Order P/N 900082-00.

Ce manuel d'installation est disponible en français, simplement en faire la demande. Numéro de la pièce 900082-00.

This appliance must be properly installed and operated in order to prevent the possibility of a house fire. Please read this entire manual before installation and use of this pellet fuel-burning room heater. Failure to follow these instructions could result in property damage, bodily injury or even death. Contact your local building or fire officials to obtain a permit and information on any installation requirements and inspection requirements in your area.



**NATIONAL
FIREPLACE
INSTITUTE**

CERTIFIED

www.nficertified.org

We recommend that our pellet hearth products be installed and serviced by professionals who are certified in the U.S. by the National Fireplace Institute® (NFI) as NFI Pellet Specialists or who are certified in Canada by Wood Energy Technical Training (WETT).



	! WARNING
	<ul style="list-style-type: none">• Hot! Do not touch! The glass and surfaces of this appliance will be hot during operation and will retain heat for a while after shutting off the appliance. Severe burns may result.• Carefully supervise children in the same room as appliance.• IHP pellet-burning appliances are designed for use as a supplemental heater. They are not intended for continuous use as a primary heat source.

IMPORTANT SAFETY AND WARNING INFORMATION

READ THIS MANUAL IN ITS ENTIRETY AND UNDERSTAND THESE RULES TO FOLLOW FOR SAFETY.

WARNING

Improper installation, adjustment, alteration, service or maintenance can cause injury or property damage. Refer to this manual. For assistance or additional information consult a qualified installer or service agency.

WARNING

Do not attempt to alter or modify the construction of the appliance or its components. Any modification or alteration may void the warranty, certification and listings of this unit.

1. DO NOT CONNECT THIS UNIT TO A CHIMNEY FLUE SERVING ANOTHER APPLIANCE.
2. Do not connect this appliance to air ducts or any air distribution system.
3. DO NOT INSTALL A FLUE DAMPER IN THE EXHAUST VENTING SYSTEM OF THIS UNIT.
4. Do not use class B venting intended for gas appliances as a chimney or connector pipe on a pellet-fired appliance.
5. The minimum clearances must be maintained for all combustible surfaces and materials including; furniture, carpet, drapes, clothing, wood, papers, etc. Do not store combustibles within this clearance space (see *Clearances on Page 6*).
6. **INSTALLATION DISCLAIMER** - It is imperative that the exhaust venting system be installed correctly and sealed gas-tight (not allowing exhaust to leak). Follow the vent manufacturer's instructions for proper installation. Since IHP has no control over the installation of your stove, IHP grants no warranty, implied or stated for the installation or maintenance of your stove, and assumes no responsibility for any consequential damage(s).
7. Burning any kind of fuel consumes oxygen. If outside air is not ducted to the appliance, ensure that there is an adequate source of fresh air available to the room where the appliance is installed.
8. The appliance will not operate using natural draft, nor without a power source for the blower and fuel feeding systems.
9. Never use gasoline, gasoline-type lantern fuel, kerosene, charcoal lighter fluid, or similar liquids to start or "freshen up" a fire in this heater. Keep all such liquids well away from the heater while it is in use.
10. The authority having jurisdiction such as municipal building department, fire department, fire prevention bureau, etc. should be consulted before installation to determine the need to obtain a permit.
11. **APPROVED FUEL:** This appliance is designed specifically for use only with pelletized wood pellets or a mixture of up to 50% corn mixed with a minimum of 50% pelletized wood pellets. This mixture of wood pellets and corn should be evenly pre-mixed before being placed in the units hopper. This appliance is designed and approved for the burning of wood residue pellets with up to 2% ash content. This appliance is NOT approved to burn cardboard, nut hulls, cherry pits, etc. regardless if it is in pellet form. Failure to comply with this restriction will void all warranties and the safety listing of the stove. Consult with your IHP dealer for more information on approved pellet fuels.
12. **CONTINUOUS OPERATION:** When operated correctly, this appliance cannot be overfired. Continuous operation at a maximum burn can, however, shorten the life of the electrical components (blowers, motors, and electronic controls), and is not recommended. Typical approved operation would include running at the low to mid range setting with occasional running on the maximum setting during the coldest periods of the winter. **DO NOT OVER-FIRE THIS STOVE.** Follow all instructions regarding the proper use of this stove.
13. **CAUTION: NEVER PUT FINGERS NEAR AUGER.** This appliance is equipped with a hopper lid switch, which is designed to stop the auger when the hopper lid is opened. **NEVER DISCONNECT OR BYPASS THIS SWITCH FOR ANY REASON.** Pellet fuel is fed to the Burn-pot by a screw auger. This auger is driven by a high torque motor. The auger is capable of causing serious harm to fingers. Keep pellets in the hopper at all times and keep fingers away from auger. The auger can start and stop automatically at any time while the stove is running.
14. **CAUTION: HOT WHILE IN OPERATION.** An appliance hot enough to warm your home can severely burn anyone touching it. Keep children, pets, clothing and furniture away. Contact may cause skin burns. Do not let children touch the appliance. Train them to stay a safe distance from the appliance.
15. **FLY ASH BUILD-UP:** For all wood pellet fuel-burning heaters, the combustion gases will contain small particles of fly-ash. This will vary due to the ash content of the fuel being burned. Over time, the fly-ash will collect in the exhaust venting system and restrict the flow of the flue gases. The exhaust venting system should be inspected regularly and cleaned as necessary.
16. **SOOT FORMATION:** Incomplete combustion, such as occurs during startup, shutdown, or incorrect operation of the room heater will lead to some soot formation which will collect in the exhaust venting system. A precautionary inspection on a regular basis is advisable to determine the necessity of cleaning. The exhaust venting system should be inspected regularly and cleaned as necessary.
17. **DISPOSAL OF ASHES:** Ashes should be placed in a steel container with a tight fitting lid and moved outdoors immediately. The closed container of ashes should be placed on a noncombustible floor or on the ground, well away from all combustible materials, pending final disposal. If the ashes are disposed of by burial in soil or otherwise locally dispersed, they should be retained in the closed container until all cinders have been thoroughly cooled.
18. The instructions must be strictly adhered to. Do not use makeshift methods or compromise in the installation.
19. Do not abuse the door glass by striking, slamming or similar trauma. Do not operate the stove with the glass removed, cracked or broken.
20. **SAVE THESE INSTRUCTIONS.**
21. See the listing label on the appliance.

CONGRATULATIONS!

When you purchased your new pellet stove, you joined the ranks of thousands of individuals whose answer to their home heating needs reflects their concern for aesthetics, efficiency and our environment. We extend our continued support to help you achieve the maximum benefit and enjoyment available from your new pellet stove.

Thank you for selecting a IHP stove as the answer to your home heating needs.

TABLE OF CONTENTS

Important Safety Information	Page 2
Packaging List	Page 3
Testing / Listing, EPA	Page 3
Using this Manual	Page 3
Planning Your Installation	Page 3
Smoke Detector Recommended.	Page 4
Carbon Monoxide Monitor Recommended	Page 4
Selecting a Location.	Page 5
Floor Protection	Page 5
Clearances	Page 6
Installation Tips	Page 8
Manufactured Home Installation	Page 9
Installation	Page 10
Venting Requirements	Page 13
Care and Operation	Page 20
Fuel	Page 25
Routine Maintenance	Page 26
Specifications.	Page 32
Component Definitions	Page 33
Wiring Diagram	Page 34
Troubleshooting	Page 35
Replacement Parts List & Diagrams	Page 37
Optional Accessories	Page 42
Warranty	Page 43
Product Reference Information	Page 44

This installation and operation manual will help you obtain a safe, efficient, dependable installation for your appliance and vent system.

PLEASE READ AND UNDERSTAND THESE INSTRUCTIONS BEFORE BEGINNING YOUR INSTALLATION

PACKAGING LIST

The assembled pellet stove model Bella™ is packaged with an accessory package which contains the following:

- One - Power Cord
- One - Installation And Operation Manual
- One - Leg Bolt Down Kit (needed for manufactured homes only)

TESTING / LISTING

Listing: The listing laboratory is PFS Corporation. The report number is 14-196 for model Bella pellet stove.

Testing: In accordance with the specifications and procedures

- Listed and tested to ASTM E1509 & ULC C1482 / ULC S627 for installations as a freestanding room heater
- The safety/listing label is located on the bottom side of the hopper lid. Please read this safety label carefully. It contains important information about installation and operation of this appliance.
- This appliance is tested and listed for residential and commercial installation according to current national and local building codes.
- This appliance is on the Colorado Approved pellet stoves list.

EPA (Environmental Protection Agency)

Status: EPA Certified (method 28) - This appliance has been tested by Lokee Testing Laboratory, Sumner, Washington to rigorous emissions standards, and has been certified by the Environmental Protection Agency.

USING THIS MANUAL

Please read and carefully follow all of the instructions found in this manual. Please pay special attention to the safety instructions provided in this manual.

PRODUCT IS SUBJECT TO CHANGE WITHOUT NOTICE

PLANNING YOUR INSTALLATION

Questions To Ask Local Building Official

A correct installation is critical and imperative for reducing fire hazards and perilous conditions that can arise when wood pellet burning appliances are improperly installed. The installer must follow all of the manufacturers' instructions.

WARNING

Check all local building and safety codes before installation. The installation instructions and appropriate code requirements must be followed exactly and without compromise. Alterations to the stove are not allowed. Do not connect the stove to a chimney system serving another stove, appliance, or any air distribution duct. Failure to follow these instructions will void the manufacturers warranty.

The installation of this appliance must conform to local codes and applicable state and federal requirements. Familiarity with these requirements before installation is essential. Important considerations to discuss with local building officials include:

1. **Applicable codes** (i.e. Uniform Mechanical Code, State or Regional Codes).

Electrical codes:

- In USA, NEC, ANSI/NFPA 70 – Latest Edition
- In Canada, CSA C22.1 – Latest Edition

2. Local amendments
3. Is a permit required - cost. You may wish to contact your insurance company to ask if they require this.
4. If outside combustion air is required
5. Rooms where the installation is not allowed

Power Supply Requirements (continued)

These requirements must be met unless otherwise specified by state or local authorities.

- **Power Cord** - The power cord must be plugged into a standard, 120 Volt, 60 Hz grounded electrical outlet with proper ground and polarity. The power cord must be routed to avoid contact with any of the hot or sharp exterior surface areas of the stove.
- **Power Supply** - The units maximum draw during start-up mode will be 3.5 Amps and 360 Watts while the igniter is on in the first 8 minutes of operation. Maximum draw on the unit once in burn mode is 1.8 Amps and 115 Watts. Minimum draw on the unit once in burn mode is 1.5 Amps and 90 Watts.
- **Manufactured Home Installations** - When installed into a manufactured home, the appliance must be electrically grounded to the steel chassis of the manufactured home (see **Page 9, Manufactured Home Requirements**).



WARNING

Electrical grounding instructions: This appliance is equipped with a three-prong (grounding) plug for your protection against shock hazard and should be plugged directly into a properly grounded three-prong receptacle. Do not cut or remove the grounding prong from this plug. Do not route power cord under or in front of appliance.

Smoke Detector Recommended

Since there are always several potential sources of fire in any home, we recommend installing smoke detectors. If possible, install the smoke detector in a hallway adjacent to the room (to reduce the possibility of occasional false activation from the heat produced by these appliances). If your local code requires a smoke detector be installed within the same room, you must follow the requirements of your local code. Check with your local building department for requirements in your area.

Carbon Monoxide Monitor Recommended

Carbon Monoxide Poisoning: Early signs of carbon monoxide poisoning are similar to the flu with headaches, dizziness and/or nausea. If you have these signs, obtain fresh air immediately. Some people are more affected by carbon monoxide than others, including pregnant women, people with heart or lung disease or anemia, those under the influence of alcohol, and those at high altitudes.

It is against federal regulations to operate wood heaters in a manner inconsistent with operating instructions in the manual.

Surge Protectors

A surge protector is recommended to ensure the stove's electrical components are not damaged due to a surge in the electrical supply. Only high quality protectors listed to UL1449 should be used - low quality protectors do not provide the protection needed.

Installation / Maintenance Standards

National Fire Protection Association – The primary NFPA standard that refers to installation and maintenance of pellet stoves and venting is NFPA 211 – Latest Edition: Chimneys, Fireplaces, Vents, and Solid Fuel appliances.

SELECTING A LOCATION

The design of your home and where you place your stove will determine its value as a source of heat. This type of appliance depends primarily on air circulation (convection) to disperse its heat, and therefore, a central location is often best. There are other practical considerations, which must be considered before a final selection of locations is made. Some of which includes:

- Existing Chimneys
- Pellet Fuel Storage
- Aesthetic Considerations
- Roof Design (rafter locations and roof pitch)
- Room Traffic
- Proximity to Combustibles
- Electrical Wiring

CAUTION

These appliances are very heavy. The use of a heavy duty escalara (stair step hand truck) is recommended for lifting the appliance.

NEGATIVE PRESSURE WARNING

This appliance is not designed to be operated in a negative pressure environment. In very airtight homes with large kitchen exhaust fans, furnace cold air returns, fresh air exchange systems and any other air system in close proximity to the heating appliance may create a negative pressure in the same room as the heating appliance. This can create dangerous condition, drawing combustion by-products into the home. Be sure your home has adequate makeup air to eliminate negative pressures caused by the above-mentioned sources. Outside air connected to the appliance probably will not resolve such a problem as the stove is not the source of negative pressure. IHP accepts no liability for damages resulting from negative pressures described here.

Ventilation Requirements - Provide adequate air for combustion. The fresh air requirements of this appliance must be met within the space where it will be installed. Ventilation is essential when using a solid-fuel-burning heater. In well insulated and weather tight homes, it may inhibit the rate the exhaust flows through the venting system (caused by a shortage of air in the home). The lack of air is caused by many common household appliances which exhaust air from the home (such as a furnace, heat pump, air conditioner, clothes dryer, exhaust fans, fireplaces, and other fuel burning appliances). Also, the combustion process of this heater uses oxygen from inside the dwelling. If the available fresh air delivery in the dwelling is insufficient to support the demands of these appliances, problems can result (i.e. excessive negative pressure will result in performance problems. To correct this problem it may help to open a window (preferably on the windward side of the house) or install an outside combustion air duct to the appliance.

FLOOR PROTECTION

This appliance requires noncombustible floor protection (**the hearth pad or alternate floor protection material does not require a thermal rating**).

A noncombustible floor protector must fully cover the area beneath the appliance as illustrated in *Figure 1*.

If the floor protection is to be stone, tile, brick, etc., it must be mortared or grouted to form a continuous noncombustible surface. In Canada, if a chimney connector / venting extends horizontally over the floor, protection must also cover the floor under the connector / venting and at least 2" (51 mm) to either side (recommended but not required in the US).

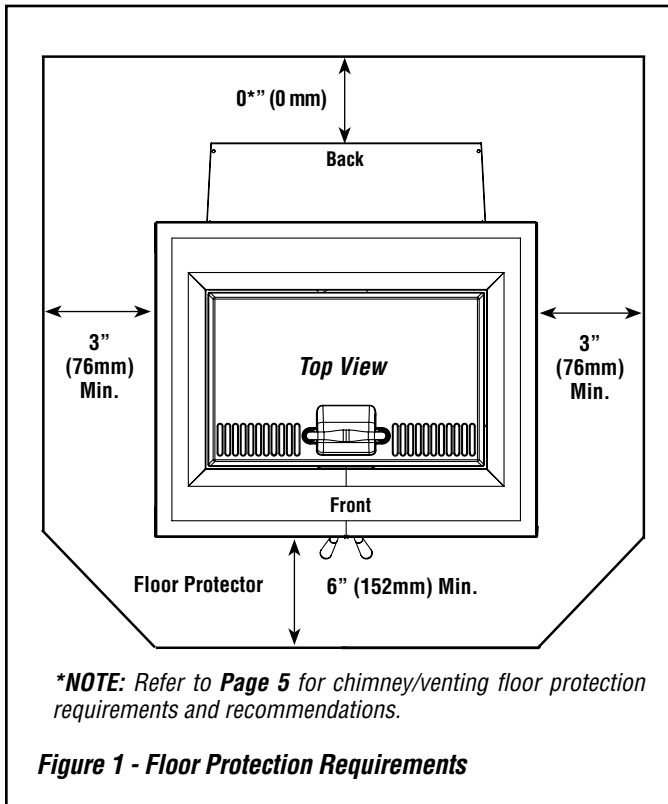

Corner Installations - Clearance to Combustibles

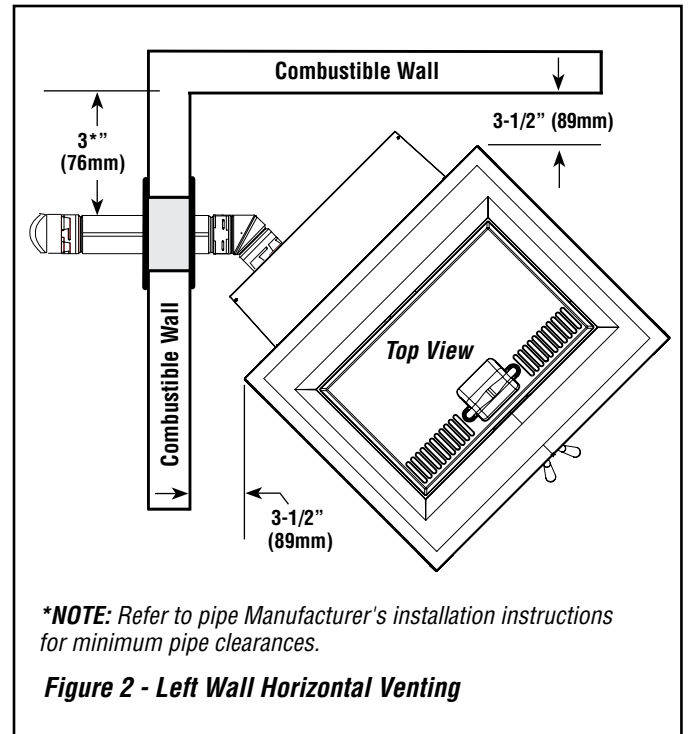

CLEARANCES

Standard residential or commercial or manufactured home installation. These appliances require the following minimum clearances to combustibles:

Minimum Clearances To Combustibles

! IMPORTANT

- **Minimum clearances specified may not allow for ease of operation and maintenance (please take this in to account when planning the installation). If installed to the minimum clearances, removal of the appliance may be necessary for servicing.**
- **Recommended clearance zone from the front of the appliance to combustibles is 4 feet minimum.**
- **Clearances to combustibles for the appliance can only be reduced by means approved by the regulatory authority.**

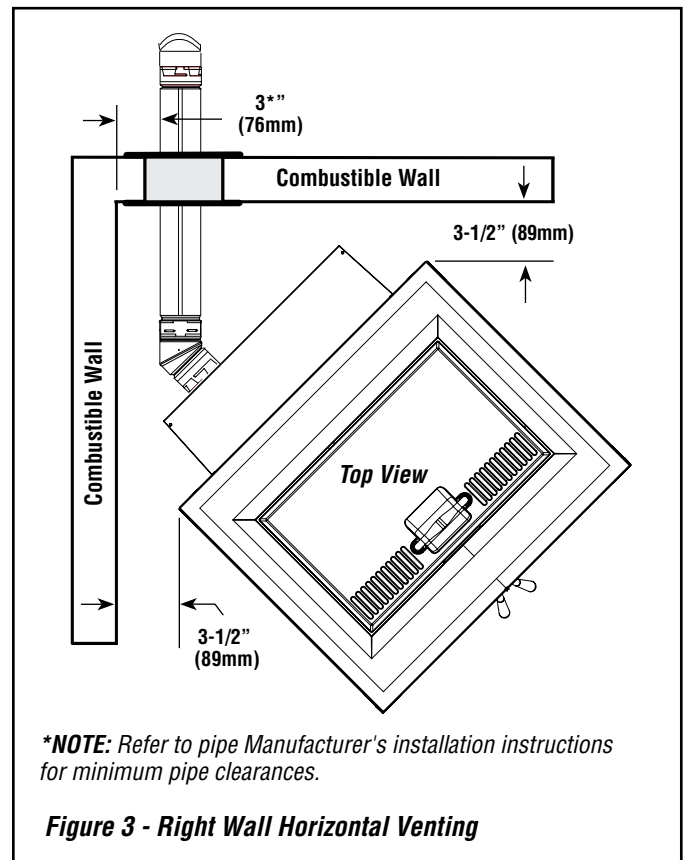

Corner Installations - Clearance to Combustibles

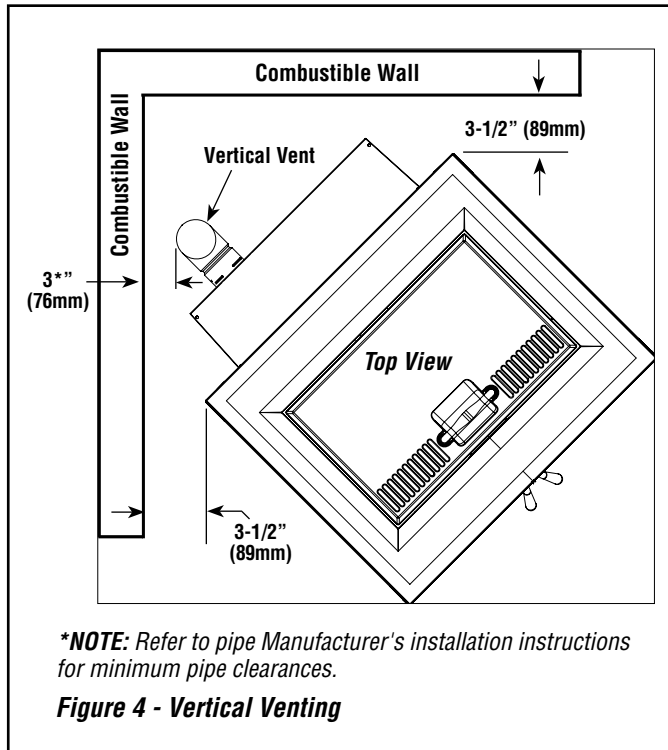

Parallel and Alcove Installations - Clearance to Combustibles

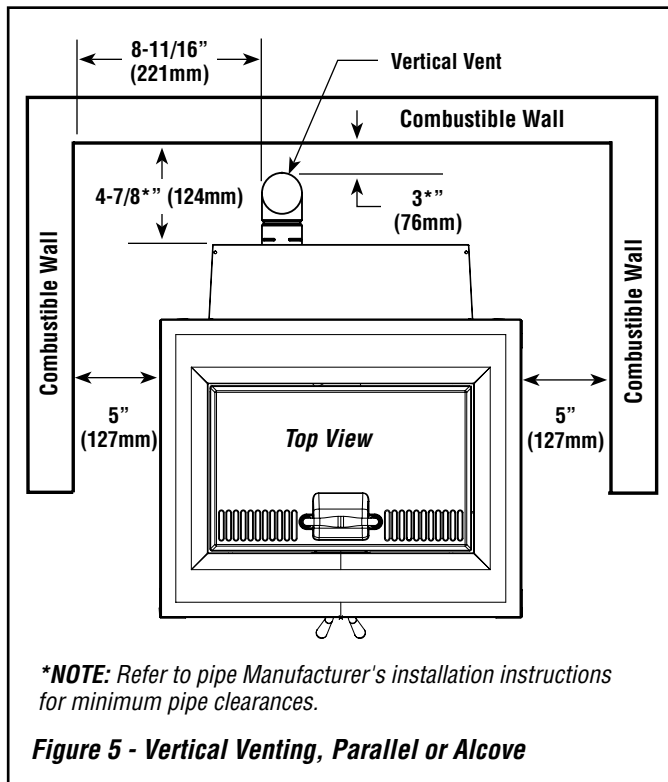

INSTALL VENT AT CLEARANCES SPECIFIED BY THE VENT MANUFACTURER.

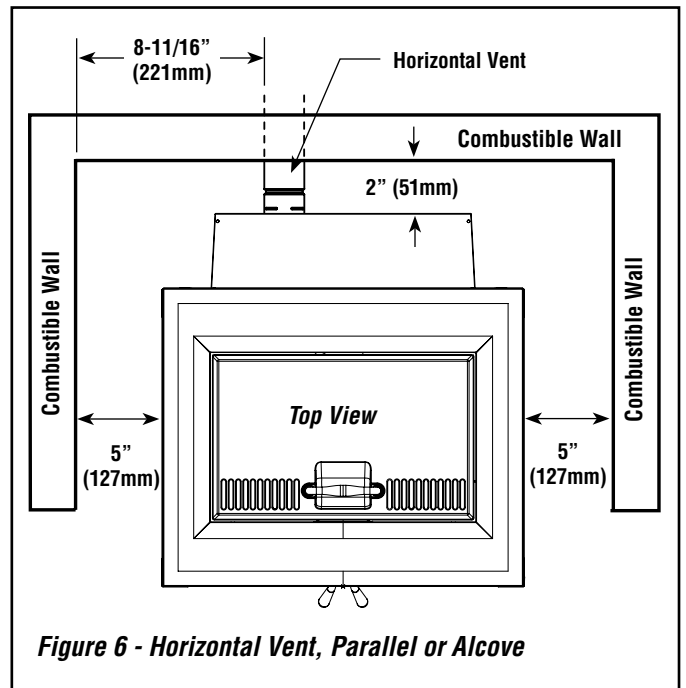

Alcove Installations - Clearance to Combustibles

- Minimum clearance from back of stove to back wall = 2 inches
- Minimum clearance from sides of stove to wall = 5 inches
- Minimum clearance from exhaust pipe to side wall = 8-11/16 inches
- Minimum height of ceiling = 60 inches
- Minimum alcove width = 33-3/4 inches
- MAXIMUM depth of alcove = 48 inches

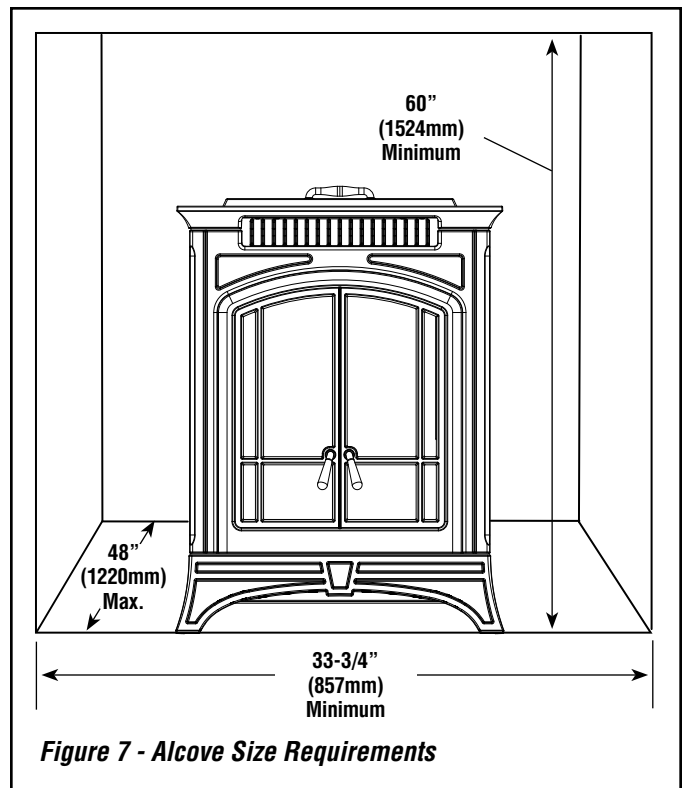

INSTALLATION TIPS

INSTALLATION TIPS
Select Your Installation Type

GOOD INSTALLATION *
Horizontal Installation
(Direct Vent - Outside Wall)

No natural draft. Wind pressures may affect operation

BETTER INSTALLATION
Vertical & Horizontal Installation
(Up and Out)

Some natural draft aids venting. Wind pressures may still affect operation

BEST INSTALLATION
Vertical Installation
(Straight Up)

Natural draft improves operation and negative effects from wind

VENTING TYPE
a: PL-Vent Pipe / Pellet Vent (w/stainless interliner)
b: Stainless Steel flex liner may be used inside existing flue or chimney (woodstove replacement applications)
CAUTION: Do not use Type B-Vent Pipe

REQUIRES 3" DIAMETER STANDARD PL-VENT / PELLETT PIPE

With listed termination kit. If installation requires in excess of 15' of pipe, it is recommended a 4" diameter pipe be used.

MANUFACTURED HOME

Requires outside air for combustion. Use a galvanized or stainless steel pipe for duct. Minimum duct size 3" I.D.

CLEARANCES TO COMBUSTIBLES

Ensure all clearances are maintained in accordance to instructions contained on product safety label and in compliance with pipe/venting requirements.

PLEASE REVIEW THIS ENTIRE INSTALLATION AND OPERATION MANUAL FOR ADDITIONAL INSTRUCTIONS.

POWER SUPPLY
Must have proper polarity and be grounded.
NOTE: Use of an extension cord may adversely effect the performance of your unit.

SEAL ALL VENTING JOINTS

Use RTV (high temp silicone)

* In horizontal vent installations It is recommended that when an appliance is vented directly through a wall, a minimum of 6 feet (1.83 M) of vertical pipe is installed to create some natural draft. This will reduce the possibility of smoke or odor entering the dwelling during appliance shutdown or loss of power.

MANUFACTURED HOME INSTALLATION

In addition to the standard installation instructions, the following instructions may be required by local, state or federal building codes:

- Installation should be in accordance with the Manufactured Home and Safety Standard (HUD), CFR 3280, Part 24.
- The stove must be permanently bolted to the floor using 1/4" diameter lag screws. The lag screws must be an adequate length to extend through the hearth pad and into the floor as shown in **Figures 8 and 9**. Install the lag screws as shown in these figures. Two lag screws must be used.
- Connecting the Bella™ stove to outside combustion air is required in manufactured home installations and when required by local building codes. An outside air inlet must be provided for combustion and be unrestricted while unit is in use. Use a galvanized or stainless steel pipe for the duct (the outside air inlet on the stove is 3" diameter). The air intake on the exterior of the home should always be located a minimum of 18" below the flue termination. The Inlet shall remain free of obstruction while unit is in operation and constructed in a manner so as to prevent material from dropping into the inlet or into the area beneath the dwelling. The inlet shall also have a screen with openings not larger than 1/4" to prevent rodents from entering. See **Figure 21**.
- Stove must be permanently electrically grounded to the steel chassis of the manufactured home using a 8 GA copper wire and a serrated or star washer (to penetrate paint or protective coating to ensure grounding). The location selected for ground attachment to the stove must be dedicated for this purpose. Grounding must comply with NFPA-70-latest edition standards, CSA C22.1-latest edition in Canada, as well as any local codes.
- See **Pages 13 through 19** for additional information on venting requirements.
- **WARNING: DO NOT INSTALL THIS STOVE IN A SLEEPING ROOM IN A MANUFACTURED HOME.**
- **CAUTION: THE STRUCTURAL INTEGRITY OF THE MANUFACTURED HOME FLOOR, WALLS, CEILING/ROOF MUST BE MAINTAINED.**

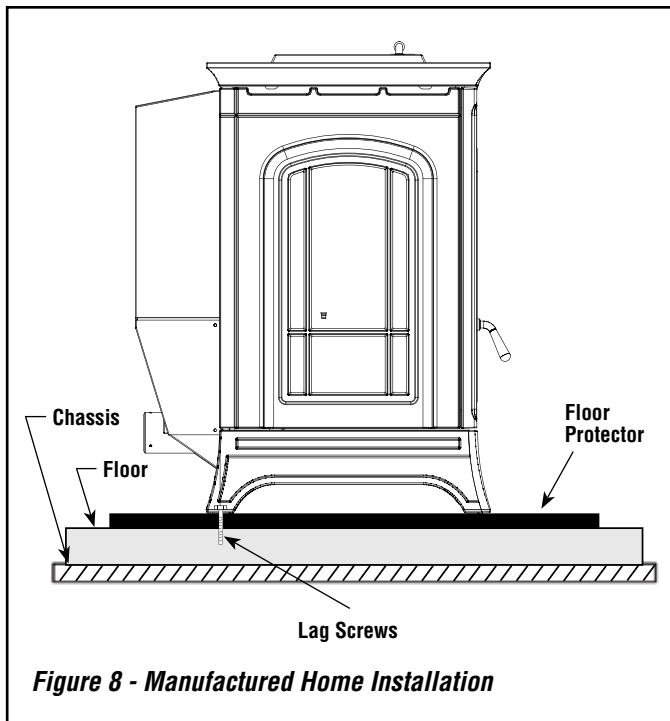
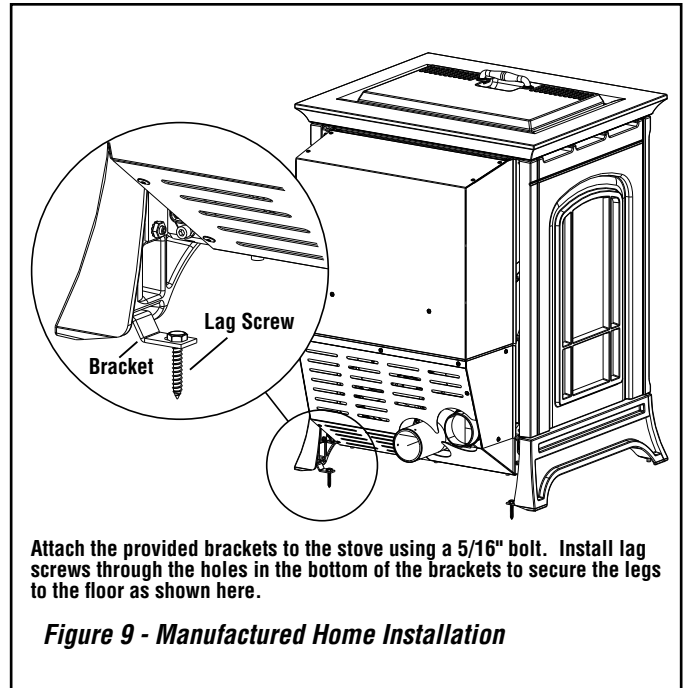

Figure 8 - Manufactured Home Installation



Manufactured Home Exhaust Vent Pipe Installation Guidelines

This stove is approved for venting with Type L and Type PL pellet vent pipe listed to UL 641 and ULC S609. The pipe should extend at least 3 feet above the part of the roof through which it passes. The top of the pipe should be at least 2 feet above the highest required elevation of any part of the manufactured home within 10 feet of the pipe (see **Page 15, Manufactured Home Chimney Height Requirements**).

If the exhaust vent exits the manufactured home at a location other than the roof, and exits at a point 7 feet or less above the ground level on which the manufactured home is positioned, a guard or method of enclosing the pipe shall be provided at the point of exit for a height of up to 7 feet. The openings, if any, in this guard shall not allow a 3/4" rod to pass through. A 1/2" rod could pass through but should not be able to touch the pipe when inserted through the opening a distance of 4 inches.

INSTALLATION

Removing Appliance From Pallet

1. After removing the packaging from the stove, lift the hopper lid, and remove all prepackaged items that were shipped in the hopper. Next, open the stove door and remove all prepackaged items.
2. Using a 7/16" socket or wrench, remove the two lag bolts on either side of the stove and remove brackets by sliding them towards the center of the unit.

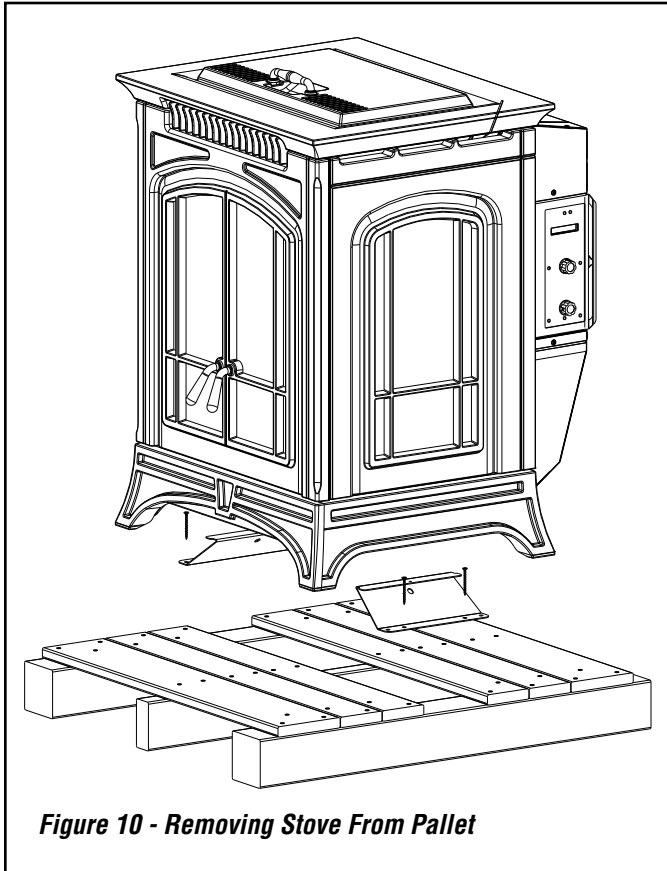

Figure 10 - Removing Stove From Pallet

Installation of Leg Leveling Bolts

An optional leg leveling kit is available. In manufactured home installations a leg bolt down kit is also required (provided with stove). Install the leveling legs per the instructions provided in kit. See **Figure 11** and **Page 42** for leveling leg kit ordering information.



H7638 Leveling Leg Kit (4 per pkg.) (ref. Form # 506033-21)

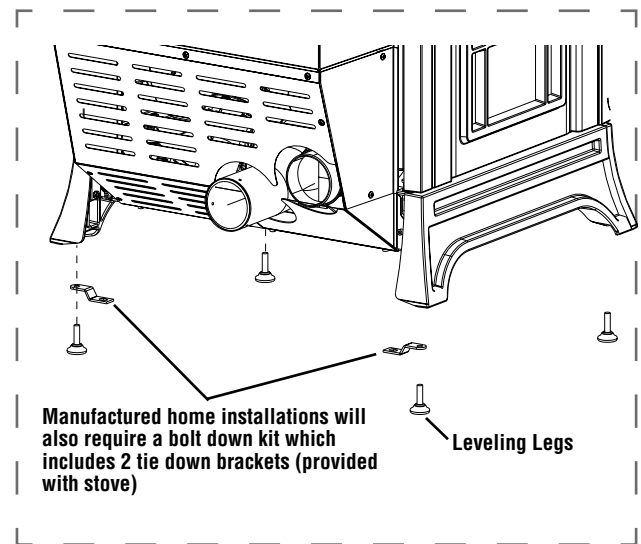
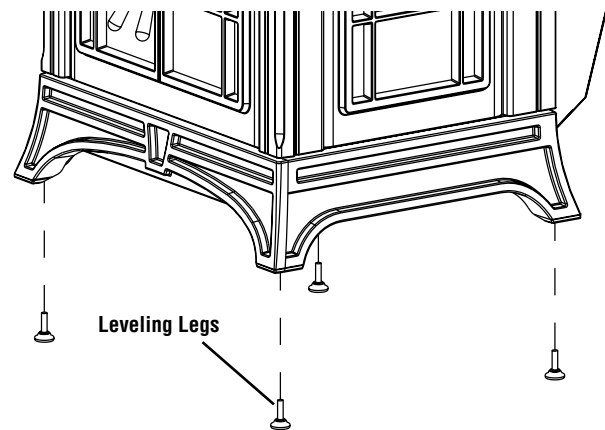

Figure 11 - Leveling Legs

Installation Check List

It is strongly recommended that you have an IHP dealer install your stove. If you install your stove yourself, you should review your installation plan with an IHP dealer.

Check list:

Check off each item as you proceed with the installation process.

- Read the ENTIRE stove installation section first
- Determine the appropriate measurements and locations for your installation.
- Follow the installation directions in this manual.
- Be sure to pre-fit all items before you install, fasten, or set up the appliance permanently.
- Measure for exhaust (also outside air tube when applicable) and mark the location. Place the unit in place to make sure it's correct before cutting holes in your wall.

Prior to lighting your appliance:

- Review the safety precautions section.
- Review the pellet *FUEL* section.
- Review and follow the Operating Instructions.
- Plug power cord connector into corresponding connector on the back of appliance (see **Figure 12** showing connector location).

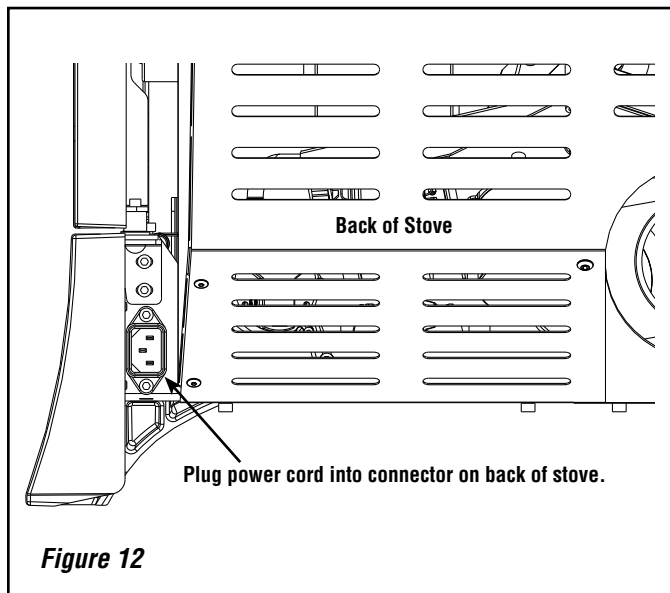

Figure 12

After you have begun operation of your appliance:

- Review the routine cleaning / maintenance information.
- Enjoy the warmth from your new IHP pellet stove!

Draft Adjuster - Adjustment Procedure

The Bella™ pellet stove has a draft adjuster located at the left side of the stove directly in front of the combustion blower. Should the stove installation require long runs of vent pipe, a situation may be created where excessive combustion air is flowing through the firebox and causing the fuel to burn faster than it can be delivered to the Burn-Pot. Should this happen, the draft can be slowed down by the adjuster. The stove is shipped with the adjuster half open. To increase or decrease the draft; using a 5/16" open end wrench, loosen the bolt (see **Figure 13**) and move the adjuster handle toward the center of the stove to decrease and away from the center of the stove to increase the draft. Retighten the screw when adjustment is complete.

Draft Adjuster

The draft adjuster controls the amount of combustion air that is delivered to the firebox (see **Figure 13**).

It will be necessary to monitor the appearance of the flame during the first 4-8 bags of pellets. If the flame is smoky red or orange with evidence of soot at the top of the flame, the draft adjuster will need to be adjusted to deliver more combustion air. If the flame is "short" at the higher burn rates and appears to burn the pellets out of the pot faster than they can be resupplied, or there are significant variations of flame height within a single burn setting, the draft adjuster may need to be adjusted to deliver less combustion air.

After the draft adjuster is adjusted, re-evaluate the appearance of the flame. It may be necessary to continue adjusting it in increments until proper combustion is achieved (the flame should become a brighter yellow and begin to "dance").

Once the draft adjuster has been properly set, and if the routine maintenance is performed as needed, the draft adjuster should not require readjustment unless you are changing from a premium grade pellet to a standard or high ash pellet, in which case the draft adjuster may need to be moved outward from center of the stove to help prevent the accumulation of ash or clinkers in the Burn-Pot.

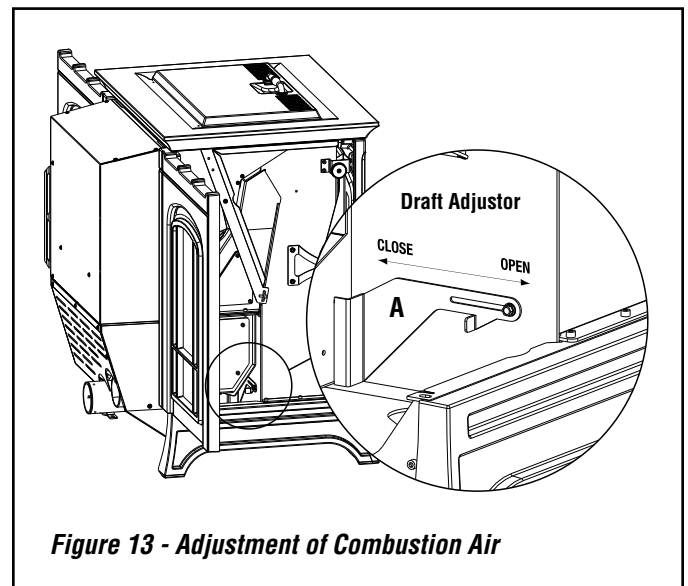

Figure 13 - Adjustment of Combustion Air

Draft Adjuster Adjustment Guidelines

Lack of Combustion Air:

By opening the draft adjuster, this will increase combustion air delivery. Symptoms of insufficient combustion air include; unburned fuel, lazy smoky or red / orange flame, excessive ash or soot, excessive buildup on glass.

Contributing factors:

- High Altitude – Lack of oxygen
- Restrictive Venting (elbows, horizontal runs, cold external chimneys, etc.)
- Dirty / Poor Quality Fuel.
- Lack of Maintenance

NOTE: Excessive amounts of fly-ash built-up in the Burn-Pot, clinkers in the Burn-Pot or leakage of air (if the Burn-Pot is not properly seated) will starve the fire for air. See Routine Maintenance, on Pages 26 through 31 for information on cleaning requirements.

Excessive Combustion Air:

Adjusting the draft adjuster to a more closed position will reduce the combustion air delivery. Symptoms of excessive air include; fuel burns too quickly (results in smoking or smoldering pellets), white to yellow flame, etc. If the draft adjuster is open too far, the burning pellets will lift off the bottom of the Burn-Pot and fly up into the air much like popping corn does. Another flame characteristic of a draft adjuster that is open too far is a flame that has significant variation in height on any single burn setting.

Contributing factor:

- Venting system providing excessive draft.
- Dry, hot burning fuel

Correct Combustion Air / Proper Burn Characteristics:

When the draft adjuster is correctly set, the burning pellets should move (wiggle) around slightly and the flame should be bright yellow.

Outside Air Installations

Connecting the Bella™ pellet stove to outside combustion air is optional, except in manufactured (mobile) home installations and when required by local building codes. The stove's air intake will accept 3" ID pipe to accommodate outside air installations. The air intake on the exterior of the home should always be located a minimum of 18" below the flue termination and must remain free of obstruction. The inlet must also have a screen with openings not larger than 1/4" to prevent rodents from entering.

Thermostat installation

The Bella pellet stove can be operated manually or by thermostat. The stove comes from the factory wired to operate manually - see control board operation on **Pages 20 through 22**. A low voltage thermostat can be installed on the stove. To install the thermostat:

1. Unplug the stove from the electrical outlet. Open the control board access door. Locate the black wiring block at the top right on the back side of the control board (see **Figure 14**). Loosen the two screws B at the back of the block, and remove the U shaped jumper wire A protruding from the block.
2. Insert a wire from the thermostat into one of the slots from which the jumper wire was removed. Repeat this process for the other thermostat wire.

Retain the jumper wire for future reinstallation. See **Page 22** for thermostat operation instructions.

IMPORTANT NOTE: Install the thermostat per the manufacturers instructions, provided with the thermostat. Failure to follow manufacturers instructions could result in a malfunction. Pay special attention to the thermostat location requirements. If the location requirements are not adhered to the appliance, erratic operation or failure may occur.

Do not mount the thermostat where it may be affected by:

- Radiant heat from the stove, fireplaces, sun or other heat sources.
- Drafts or dead spots behind doors or in corners.
- Hot or cold air from ducts.

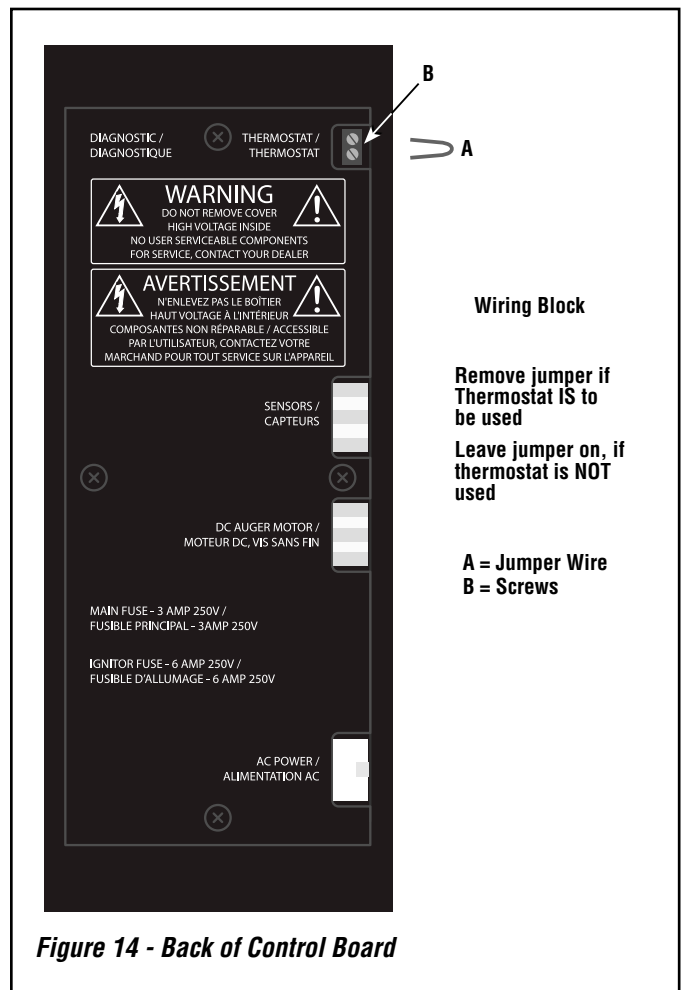

VENTING REQUIREMENTS

It is recommended that only an IHP dealer install your pellet stove. The specified installation requirements must be followed to ensure conformity with both the safety listing of the appliance and local building codes. All clearances, installation instructions and precautions specified by the vent manufacturer must be followed.

Selecting a Location

Review the appliance clearance requirements before installing the venting system (see **Pages 5, 6 and 7**). Position the appliance far enough away from walls to allow adequate room for servicing. Choose the appliance location with the least amount of interference with the house framing, plumbing, wiring, etc.

Preferred Vent Configuration

For the best performance, we recommend a vent run design which runs vertically and terminates above the roof line. This design will allow natural draft to improve the flow of flue gases and will aid in combustion and stove performance.

Type of Pipe

This stove is approved for venting with Type L and Type PL pellet vent pipe (sometimes referred to as “L-Vent pellet vent”, listed to UL 641 or ULC S609). Connect the pellet vent pipe or the “tee” to the flue collar using a minimum of three screws and seal as specified in “Pipe/Liner Joint Requirements” on this Page. **Do not use class B gas chimney or single wall chimney as a substitute.**

Size of Pipe

These pellet stoves are approved for use with the following vent sizes: 3” (75 mm) standard, or 4” (100 mm), see **Page 16** - for determining correct size vent. When 4” pipe is used: for horizontal vent installations use a 3” (75 mm) to 4” (100 mm) adaptor - available from vent manufacturer. For vertical installations use a 3” (75 mm) to 4” (100 mm) “tee” - available from vent manufacturer.

Offsets

In every installation, a single or double clean-out “tee” is recommended for every ninety-degree offset (this tee will help collect ash residue and will allow for routine cleaning without the need to disconnect sections of pipe).

Pipe Clearances/Requirements

See pipe manufacturers instructions for installation of venting components and clearances. Follow pipe manufacturers installation precautions for passing pipe through a combustible wall or ceiling (i.e. use an approved thimble).

Notes

- *Offsets and horizontal runs accumulate fly-ash and soot which reduces the exhaust flow and performance of the stove.*
- *Total Offsets in venting system should not exceed 270° total in direction change.*
- *Maximum Vertical Vent - 30 feet (9.14 M)*
- *Horizontal Runs - The maximum total horizontal run must not exceed 10 feet (3.1 meters).*
- *Horizontal run of pipe requires 1/4” (7 mm) rise per foot.*
- *Pellet vent pipe requires 3” (75 mm) clearance from outside of pipe unless otherwise specified by vent manufacturer - all diameters: 3” (75 mm) and 4” (100 mm). A support bracket must be installed every 4 feet (1.2 m) of pellet vent pipe on the exterior wall of the house unless otherwise specified by vent manufacturer.*
- *It is not recommended to terminate exhaust vent on the prevailing wind side of the house.*
- *In Canada, where the venting may pass through a wall, or partition of combustible materials, the installation shall conform to CAN/CSA-B365. When installing the wall thimble and other venting components, follow the vent manufacturers instructions. Maintain an effective vapor barrier at the location where the chimney or other component penetrates to the exterior of the structure.*

Pipe/Liner Joint Requirements

Silicone sealant and three screws are required to secure the first vent connection to the appliance flue collar. Secure the remaining vent sections using (3) three screws minimum per section, unless otherwise specified by vent manufacturer’s instructions. ALL horizontal joints must be sealed gas-tight (air tight, sealed connection). Use RTV high temperature silicone or Interam, if necessary, to provide a complete seal between vent sections.

Connection to Masonry Chimney through a Wall

Be sure to verify the construction of a masonry chimney, as it may have combustible framing.

Approved liner when relining Masonry or Factory-Built Fireplaces is 2100HT (degree F.) liner listed to UL 1777 or ULC S635.

Connection to an Existing Class A Chimney

A chimney adaptor can be used to make the connection from 3” (75 mm) or 4” (100 mm) pellet vent pipe (listed to UL 641 or ULC S609) to existing UL chimney system. Verify with the pipe manufacturer that your pipe brands will interconnect.

Horizontal Vent Installations

On all horizontal vent installations (short, horizontal runs with no vertical pipe); care should be taken when choosing a location for terminating the vent. It is not recommended to directly vent the exhaust on the prevailing wind side of the house. It is recommended that when an appliance is vented directly through a wall, a minimum of 6 feet (1.83 M) of vertical pipe should be installed to create some natural draft. This will reduce the possibility of smoke or odor entering the dwelling during appliance shutdown or loss of power.

Vent Termination

Do not terminate vent in an enclosed or semi-enclosed area such as: carports, garage, attic, crawl space, under a deck, porch, narrow walkway, closely fenced area, or any location that can build up a concentration of fumes such as a stairwell, covered breezeway etc.

Vent surfaces can get hot enough to cause burns if touched. Adults should supervise children when they are in the area of a hot stove. Non-combustible shielding or guards may be required.

Termination Cap

The termination of the outside chimney of the pellet stove shall be located in accordance with the following:

- A. Higher than 3 feet (.92 m) above any forced air inlet (air conditioner, etc.) located within 10 feet (3 m).
- B. Not less than 4 feet (1.2 m) below, 4 feet (1.2 m) horizontally from or 1 foot (3.1 m) above any gravity air inlet (door, window, etc.) which flue gases could reenter the dwelling.
- C. Not less than 2 feet (.6 m) from combustible materials such as an adjacent buildings, fences, protruding parts of the structure, roof overhang, plants and shrubs, etc. and not less than 7 feet (2.1 m) above grade when located adjacent to the public sidewalks (access). The final termination of the exhaust system must be configured so that flue gases do not jeopardize the safety of people passing by, overheat combustible portions of nearby structures or enter the dwelling.
- D. The distance from the bottom of termination to grade is 12” (305 mm) minimum unless otherwise specified by the vent manufacturer. This is conditional upon plants and nature of grade surface: Be careful to choose a location for the vent termination which does not expose people or shrubs to high heat from the exhaust gases. The exhaust gases are not hot enough to ignite grass, plants and shrubs located in the vicinity of the termination although they should be a minimum of 3 feet (.92 m) away. The grade surface under the termination must not be a lawn.
- E. Since sparks may escape from the exhaust pipe of any stove, use caution when positioning the vent pipe. Refer to pipe manufacturer’s instructions when installing and terminating the exhaust. The vent pipe should be horizontal and never run the pipe in a downward direction (recommend a 1/4” [7 mm] rise per foot horizontal).

Vent Termination Locations

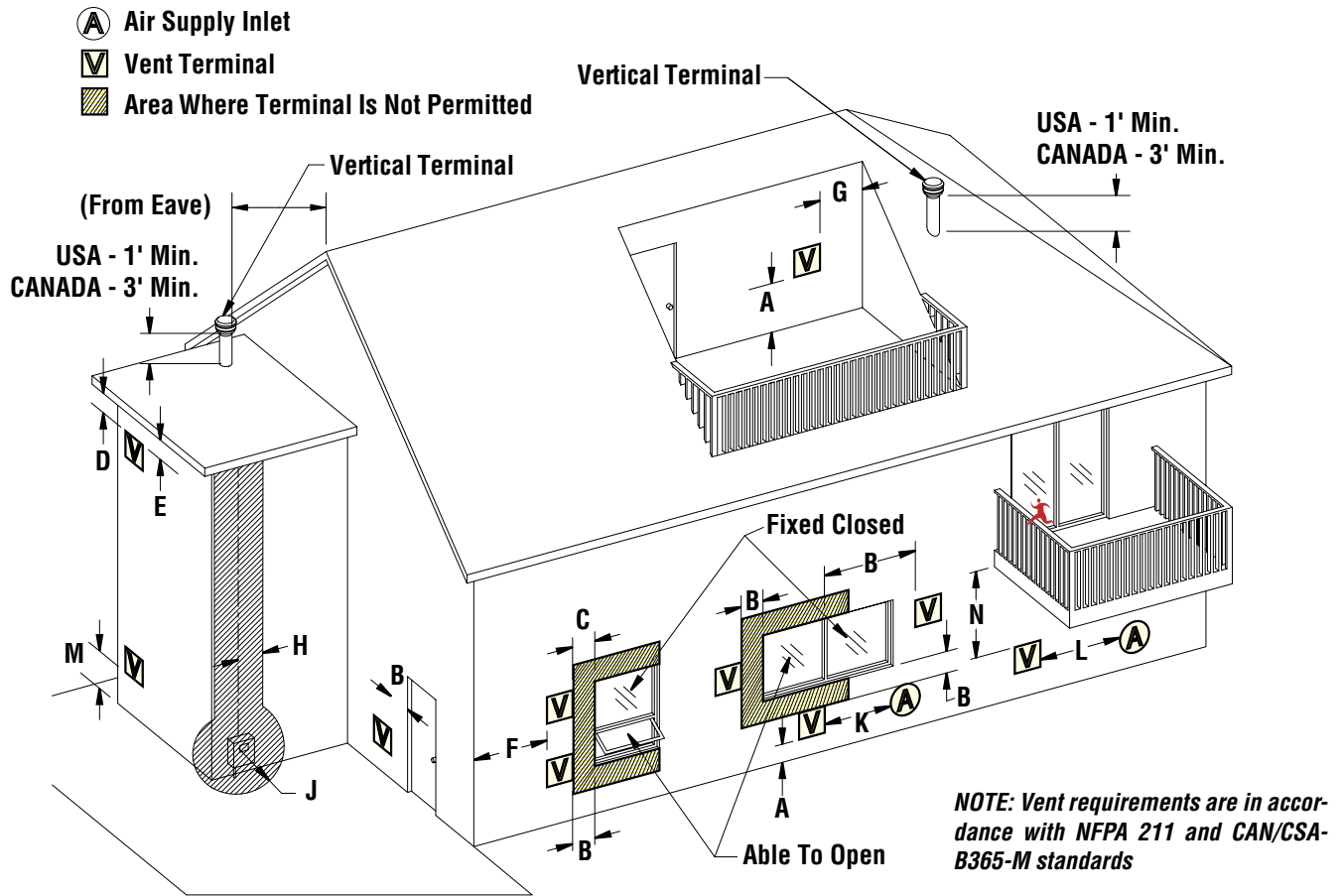

- A = Refer to vent manufacturer's installation instructions for the required clearance above grade, veranda, porch, deck, or balcony.
- B = Clearance to window or door that may be opened (min. 12"/30cm above - 48"/1.2m below and to the side).
- C = Clearance to permanently closed window *(min. 12"/30cm).
- D = Vertical clearance to ventilated soffit located above the terminal within a horizontal distance of *(min. 24"/60cm) from the centerline of the terminal (min. 22"/55cm) check with local code.
- E = Clearance to unventilated soffit *(min. 12"/30cm).
- F = Clearance to outside corner *(min. 12"/30cm).
- G = Clearance to inside corner *(min. 12"/30cm).
- H = Not to be installed above a meter/regulator assembly within *(min. 36"/90cm) horizontally from the centerline of the regulator.
- J = Clearance to service regulator vent outlet *(min. 72"/1.8m).
- K = Clearance to non-mechanical air supply inlet to building or the combustion air inlet to any other appliance *(min. 48"/1.2m).

- L = Clearance to a mechanical air supply inlet *(min. 120"/3.1m).
- M = **Clearance above paved sidewalk or a paved driveway located on public property *(min. 84"/2.1m).
- N = ***Clearance under veranda, porch, deck, or balcony (min. 12"/30cm).

NOTES:

- * Local codes or regulations may require different clearances.
- ** A vent shall not terminate directly above a sidewalk or paved driveway which is located between two single family dwellings and serves both dwellings.
- *** Only permitted if veranda, porch, deck, or balcony is fully open on a minimum of two sides beneath the floor.

Figure 15

Chimney Height Requirements - Site Built Residential Home

The vent termination height required is - USA, 1-foot minimum; Canada 3-feet minimum above the roof penetration point as illustrated below (Ref. USA - National Standard, NFPA 211-latest edition and Canada National Standard CSA B365-01-latest edition. Check with your local building official for additional requirements for your area.

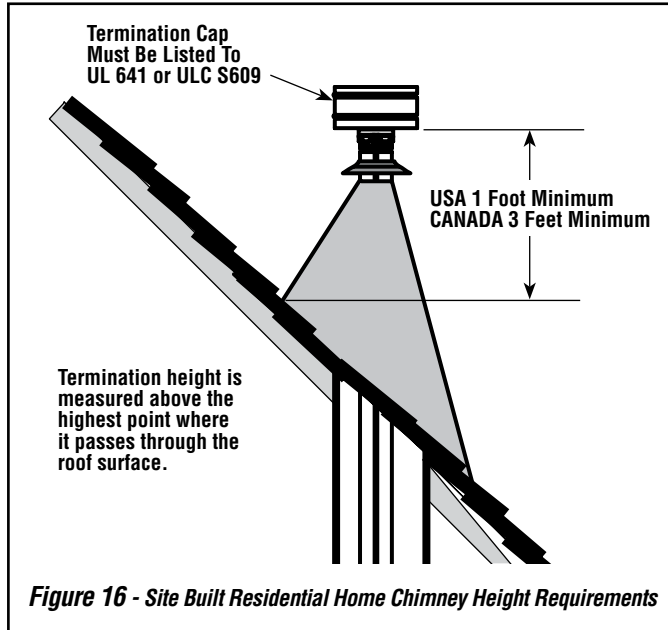

Chimney Height Requirements - Manufactured Homes

The chimney must extend 3 feet (.92m) above the level of roof penetration and a minimum of 2' (.61m) higher than any roof surface within 10 feet (3m) (see **Figure 17**). Check with your local building officials for additional requirements for your area.

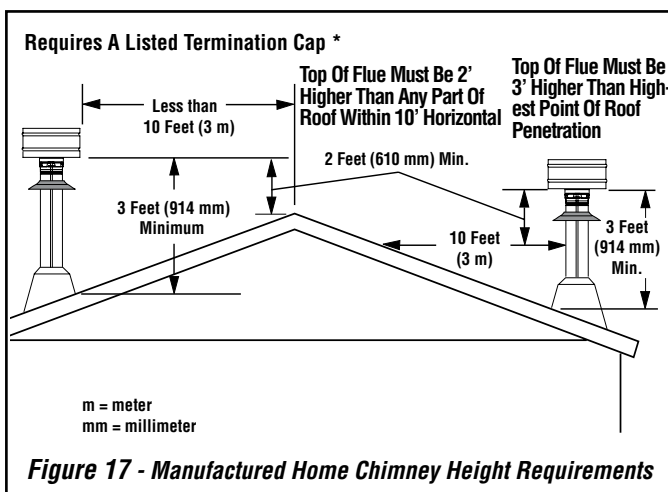

To pass inspection in nearly any jurisdiction, the chimney must meet both safety and exhaust flow requirements. The (3' by) 2' by 10' rule applies to both masonry and factory-built chimneys.

*** Ref. USA - National Standard, NFPA 211-latest edition and Canada National Standard CSA B365-01-latest edition. Vents installed with a listed cap shall terminate in accordance with the terms of the cap's listings.**

Termination When Connected to Masonry Chimney or Existing Class A Chimney

A flexible corrugated chimney liner has much greater resistance to the flow of flue gases than does a rigid liner. For this reason we recommend that a larger, 4" liner be used on vertical runs exceeding 15 feet or that rigid venting be used. See **Figure 18**.

If a flexible corrugated chimney liner is used, it must be fully extended to eliminate any sagging and to improve the exhaust flow.

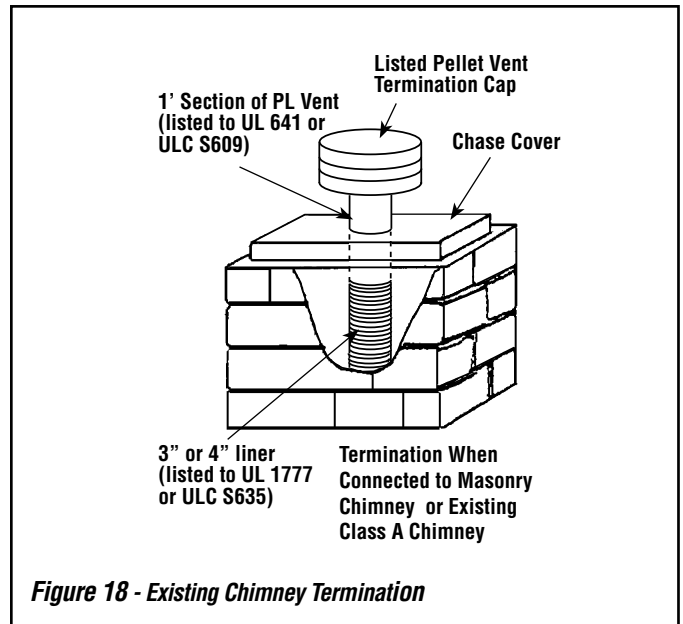

Determining Size Of Pipe To Install

To determine what diameter pipe to use in an installation (3" or 4"), first find the "equivalent pipe length" using the following guidelines, then plot this number and the altitude on the chart (**Figure 19**).

Fill out the installation chart, and calculate your total equivalent pipe length. After you have the total equivalent pipe length, use the *Pipe Selection Chart (Figure 19)* to determine if your installation requires 3" or 4" exhaust pipe.

Installation Chart

Type of Pipe	# of Elbows or Feet of pipe		Equivalent Feet	Total Equivalent Feet
90° Elbows/ Tee (A & G)		x	5 Feet (1.5 m)	
45° Elbows (C)		x	3 Feet (1 m)	
Horizontal (B & F)		x	1 Feet (.3 m)	
Vertical (E)		x	.5 Feet (.15 m)	

Table 1

Sample Installation Chart

Type of Pipe	# of Elbows or Feet of pipe		Equivalent Feet	Total Equivalent Feet
90° Elbows/ Tee (A & G)	2	x	5 Feet (1.5 m)	10 (3 m)
45° Elbows (C)	1	x	3 Feet (1 m)	3 (1 m)
Horizontal (B & F)	3	x	1 Feet (.3 m)	3 (1 m)
Vertical (E)	8	x	.5 Feet (.15 m)	4 (1.2 m)
Total Equivalent Feet =				20

Table 2 - Sample Chart for Figure 20

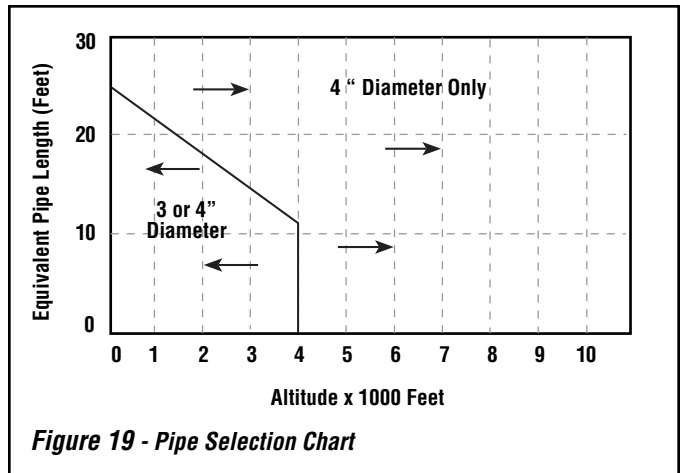

Figure 19 - Pipe Selection Chart

NOTE: All equivalent pipe styles shown for model Bella™ pellet stove.

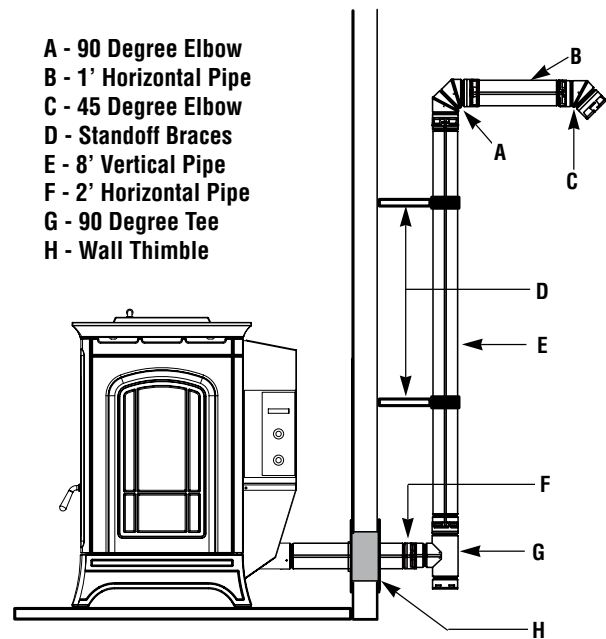

Figure 20 - See Sample Installation Chart

Standard Horizontal Vent Installation

Installing the Bella™ Pellet Stove

This stove is approved for venting with Type L and Type PL pellet vent pipe listed to UL 641 or ULC S609.

1. Locate the proper position for the listed type "PL" wall thimble. Avoid cutting wall studs when installing your pipe. Use a saber saw or keyhole saw to cut the proper diameter hole through the wall to accommodate the wall thimble. Use extreme caution to avoid cutting into power lines within the wall of the home. The hole size will depend on the brand of pellet vent that you are using. Install the wall thimble in the hole.
2. **ALL INTERLOCKING PIPE CONNECTIONS MUST BE SEALED GAS-TIGHT AND SECURED TOGETHER PER VENT MANUFACTURER INSTRUCTIONS.**

Position the stove approximately 12" (305 mm) from the wall on the floor pad. Push the "PL" pipe through the wall thimble. Squeeze a bead of high temperature silicone (RTV) sealer around the end of the machined portion of the 3" (76 mm) pipe connector on the back of the stove. Firmly push on a section of "PL" pipe until inner pipe liner pushes into the bead of RTV sealer.

3. Push the stove with pipe attached towards the wall (the pipe will go through the wall thimble). Do not position the back of the stove closer than 2" (51mm) from the wall (see *Clearances, Pages 6 and 7*).

4. Install listed type "PL" 45 degree elbow with rodent screen or cap on outside end of pipe. The Inlet shall remain free of obstruction while unit is in operation and constructed in a manner so as to prevent material from dropping into the inlet or into the area beneath the dwelling. The inlet shall also have a screen with openings not larger than 1/4" to prevent rodents from entering.
5. If the installation includes a source of outside combustion air; cut a separate hole through the wall for the fresh air tube. This tube should be 3" (762 mm) minimum diameter I.D., steel only. Connect outside air pipe to air inlet on stove. This tube must be terminated with a 45 degree elbow or hood.

NOTES:

- Combustion air may also be drawn from a vented crawl space under the home.
- All joints for connector pipe are required to be fastened together per the vent manufacturers instructions. If vented horizontally, joints must be made gas-tight (air tight, sealed connection) in a manner as specified on this page (see instruction #2). **INSTALL VENT AT CLEARANCES SPECIFIED BY THE VENT MANUFACTURER.**
- Greater back clearance will improve the ease of serviceability of the stove.
- The end of the exhaust pipe must extend a minimum distance from the outside of the building. Refer to the vent manufacturer's instructions for this clearance requirement.

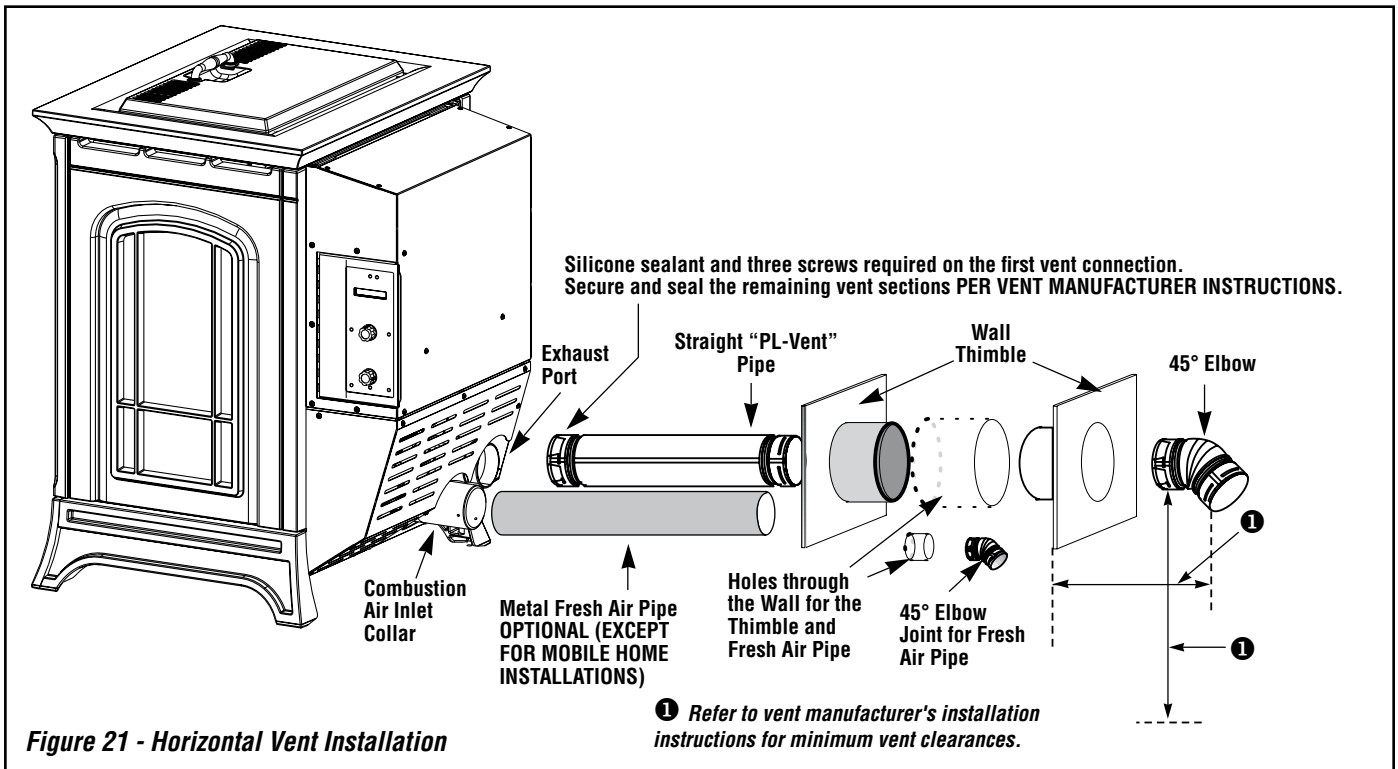

Masonry Chimney

When venting into a masonry chimney, the pellet pipe can terminate just inside the chimney. However, it is recommended to run the pellet pipe to the top of the chimney.

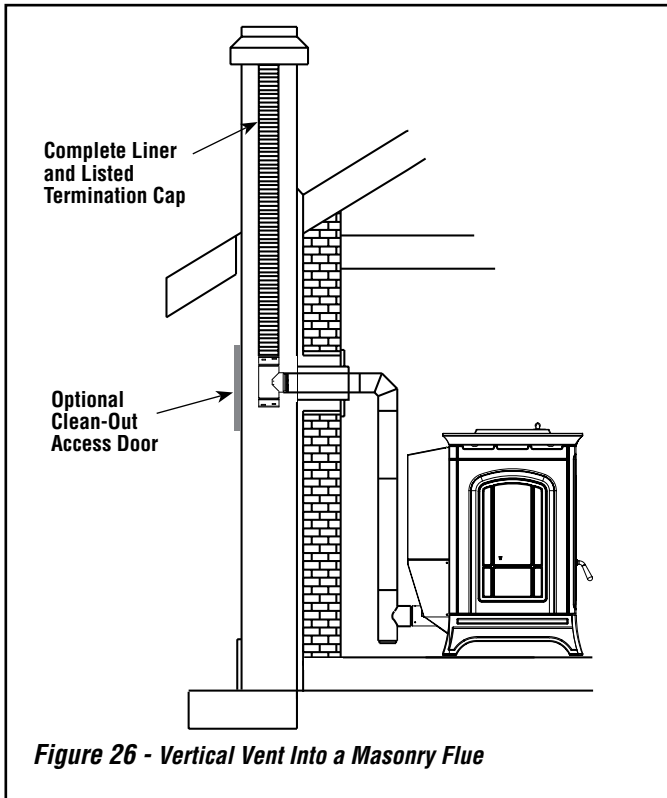

Fireplace

When venting into a fireplace chimney, the pellet pipe can terminate just above the damper. However, it is recommended to run the pellet pipe to the top of the chimney.

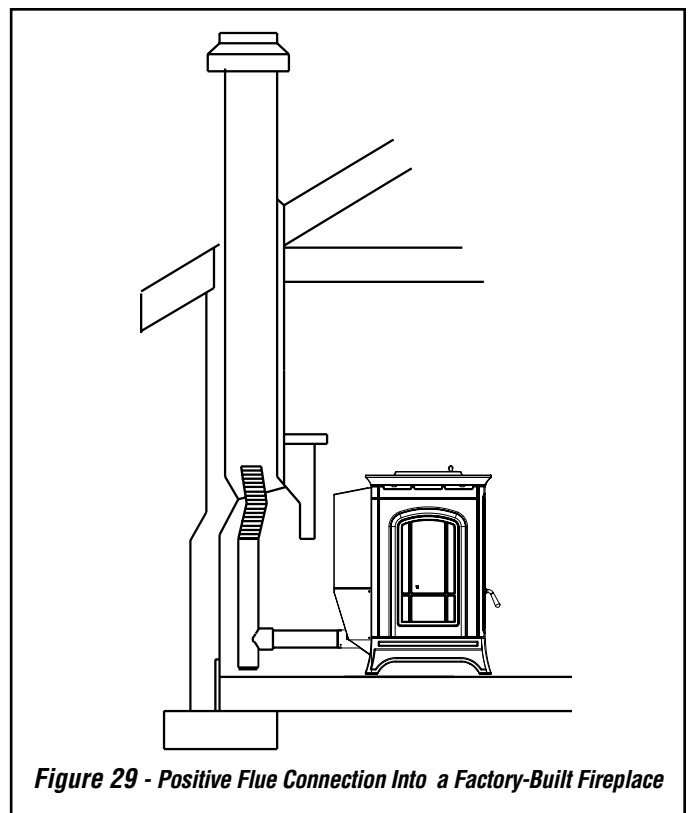
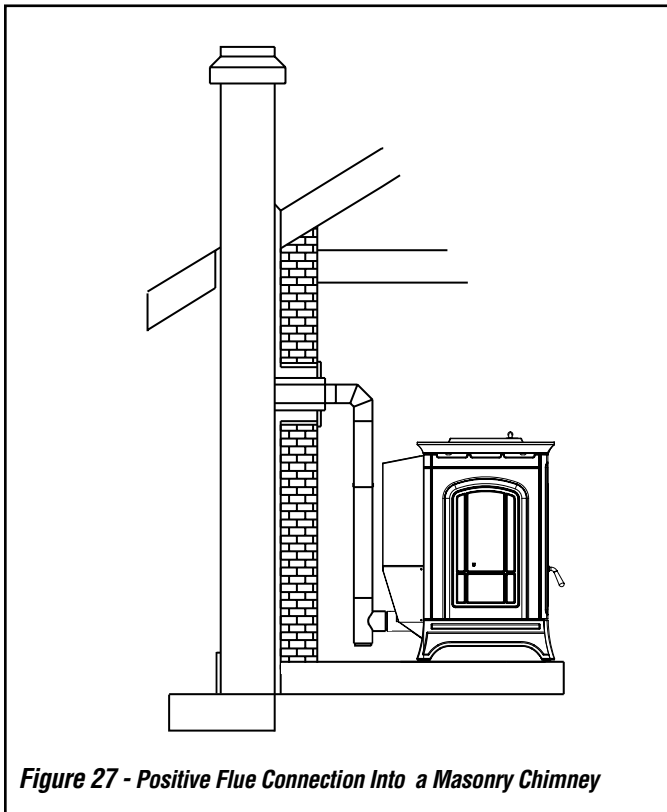
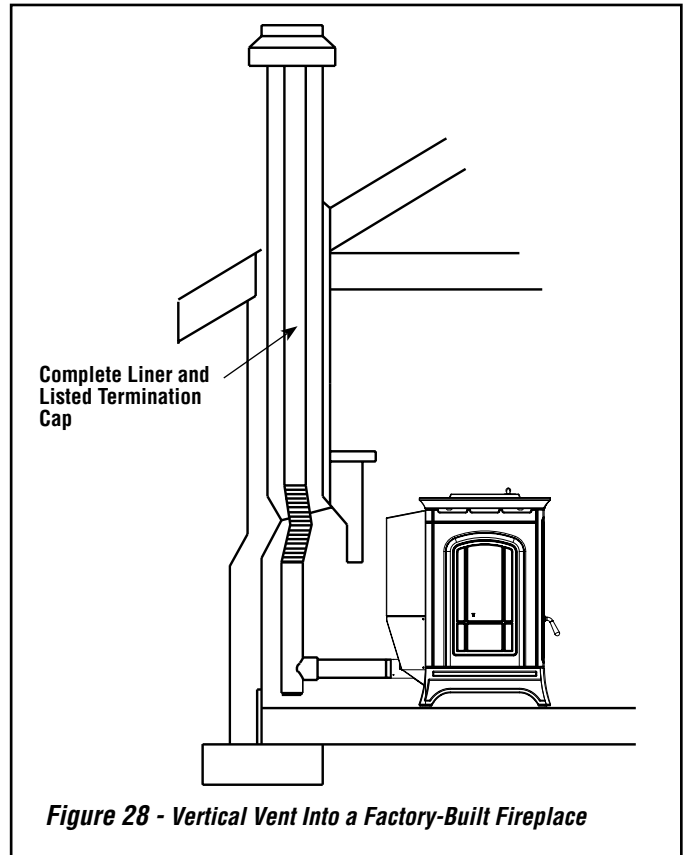

CARE AND OPERATION

Simple Operating Instructions

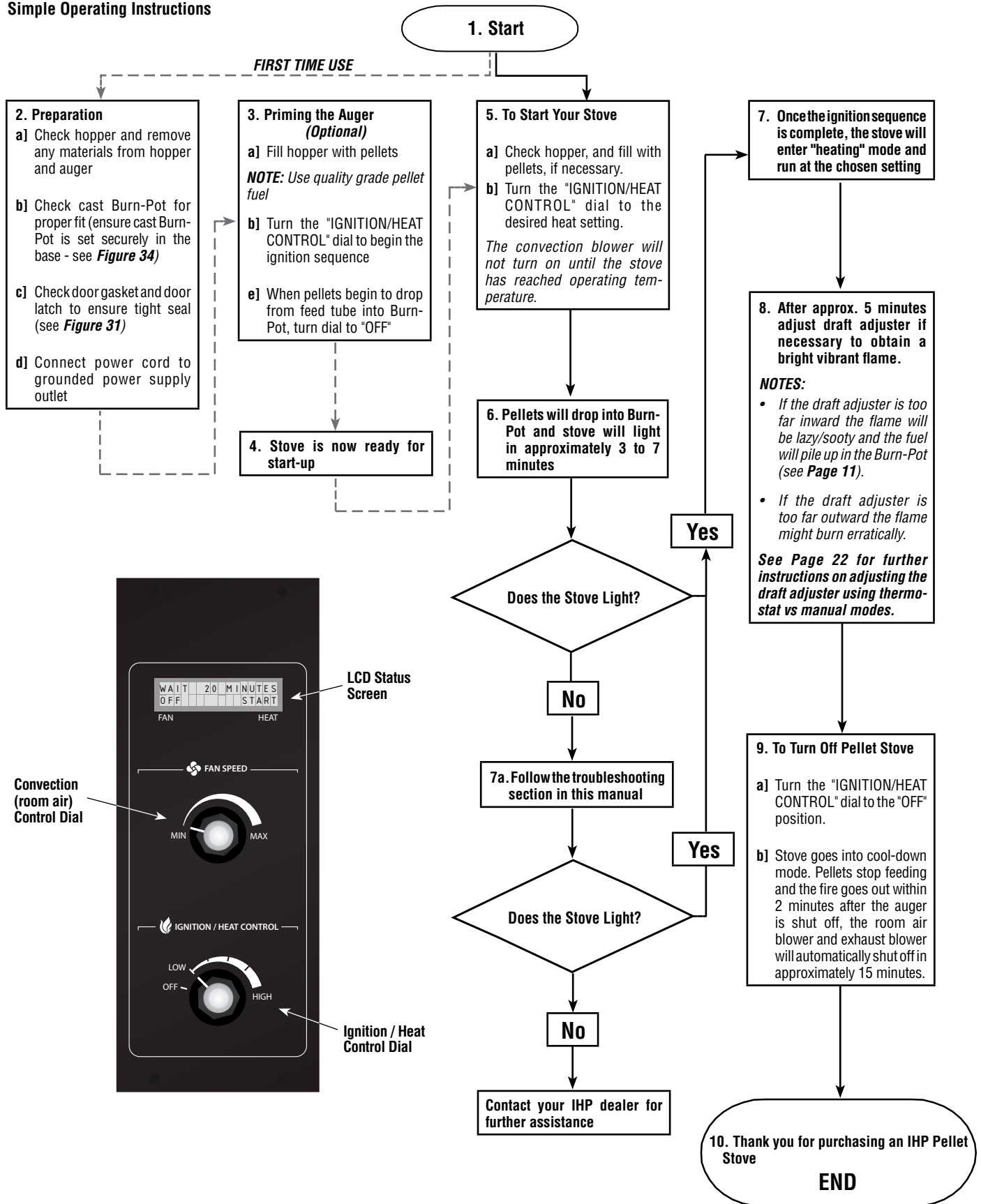

Control Board

The control board has a six position integrated switch which controls the fuel feed rate, combustion blower speed and room air blower speed simultaneously. There is a separate blower speed control that overrides the integrated switch which will allow you to reduce the speed of the room air blower, thus reducing the noise level of the stove.

The control board regulates all functions of the stove. The following is a list of the board's components:

- **LCD Display Screen** - See *LCD Screen Displays* on **Pages 22 through 24**. The LCD display provides information on the status of the stove, burn mode, failure mode, burn setting, time left in start-up cycle etc. which should result in reduced diagnosis time.
- **Room Air Blower Speed** - Adjusts blower speed from low to high settings. When adjusting to lower speed settings, the feed rate may adjust accordingly to the blower speed, so the stove will not overheat.
- **Ignition / Heat Control**- Initiates ignition and controls the level of heat output from the stove.
- **Igniter Fuse** - Six amp fuse to protect the igniter heating element.
- **Control Board Fuse** - Three amp fuse to protect the control board.



Figure 30 - Control Board

NOTE: Upon the stove's initial light up, or if the stove has previously run out of pellets, the auger feed tube may not contain a sufficient number of pellets to allow the stove to continue burning after the ignition sequence. It may be necessary to initiate the startup a second time by turning the Ignition/Heat Control dial to the "off" position and then back to your desired heat setting. It is important to always empty (when cool) the Burn-Pot of pellets before starting the stove a second time.

WARNING

Never empty pellets from the Burn-Pot into the hopper. Pellets that may appear to be cool may retain enough heat to ignite other pellets resulting in smoke or fire damage.

DO NOT OVERFIRE THIS STOVE. This may cause serious damage to your stove and void your warranty. It also may create a fire hazard in your home. IF ANY EXTERNAL PART OF THE UNIT BEGINS TO GLOW, YOU ARE OVERFIRING. Immediately turn the heat control dial to the "OFF" position.

Filling the Hopper

To fill the hopper when stove is off:

1. Lift the hopper lid to it's full opened position.
2. Fill the hopper with pellets.
3. Check to make sure there are no remaining pellets on top of the hopper that may prevent the hopper lid from fully closing.
4. Close Hopper lid.

To fill the hopper when stove is in operation:

1. Repeat steps 1 thru 4 above.
2. When finished, check the LCD screen on the controller to verify that the stove is still in normal heating mode.
3. If the message on the screen does not say "Heating" rather it alternates between "Hopper Left Open" and "Cooling Down" simply reset the stove by turning the Heat Control Dial to "Off" and then back to your desired heat setting and the stove will run the igniter for 4-5 minutes to make sure there is a sustainable fire after refueling.

NOTE: This is an exclusive feature of the Bella™ to assure the highest reliability, safety and convenience.

Lighting

Follow instructions on **Page 20**.

Manual Operation

After the stove is burning (see lighting instructions on **Page 20**), the heat control dial controls the pellet burn rate and the stove's heat output. Turning the dial to the low setting allows the stove to burn about 1.8 pounds of pellets per hour. Turning the dial to high allows the stove to burn 4.9 pounds of pellets per hour. Once set, the stove will continue to burn at this rate until shut off.

Thermostat Operation

This stove will operate with a low voltage thermostat. See **Page 12** for instructions on installing the optional wall thermostat. Once installed, the thermostat will control the operation of the stove.

IMPORTANT: When connected to a thermostat, it is necessary to turn the heat control dial to your desired heat setting for the initial burn. After the initial ignition sequence, when the thermostat calls for heat (the room temperature is less than the temperature set on the thermostat) and the heat control dial is not in the off position, the stove will burn at the heat control dial setting. The higher the setting, the quicker the room will heat up. Once the thermostat no longer calls for heat (the room is up to the desired temperature), the stove will continue to burn for one additional hour at the lowest setting. If the thermostat does not call for heat again during that hour, the stove will shut off. During that hour, if the thermostat calls for heat again, the stove will again burn at the heat control dial setting until the thermostat no longer calls for heat. If the stove shuts off after that hour it will relight when the thermostat calls for heat.

LCD Display Screen - Normal Mode Screens

1 IGNITING																
1A					I	G	N	I	T	I	N	G				
1B	W	A	I	T		#	#		M	I	N	U	T	E	S	
2	%	%	%	%								S	T	A	R	T

- The stove has been switched on to your desired heat sequence #1 through #5. Your stove is in IGNITE/START-UP mode which is a preset sequence which will run 11 to 20 minutes and will switch to NORMAL HEATING mode when sufficient temperature has been reached.

2 HEATING																
1A					H	E	A	T	I	N	G					
1B					H	E	A	T	I	N	G					
2	%	%	%	%					@	@	@	@	@	@	@	@

- Your stove has entered NORMAL HEATING mode and is burning on the heat setting indicated in the lower right corner of the LCD Screen as well as the heat control dial.

3 HOPPER OPEN - IGNITING																
1A	C	L	O	S	E		H	O	P	P	E	R		L	I	D
1B	I	G	N	I	T	I	O	N			P	A	U	S	E	D
2		S	H	U	T	D	O	W	N		I	N		\$	\$	

- The hopper lid switch circuit is open which indicates the hopper lid is not properly closed during the ignition sequence. If the hopper lid remains open, the shutdown cycle will start within the time indicated on the display screen. See **Page 33** for more information about the hopper switch.

4 HOPPER OPEN - HEATING																
1A	C	L	O	S	E		H	O	P	P	E	R		L	I	D
1B		F	U	E	L		F	E	E	D		O	F	F		
2		S	H	U	T	D	O	W	N		I	N		\$	\$	

- If the hopper lid remains open for more than 45 seconds the stove will enter it's COOL DOWN mode followed by the FINAL SHUTDOWN mode. To reset, turn the heat control dial to off and then back on to your desired setting. See **Page 33** for more information about the hopper switch.

5 HEAT LIMIT																
1A					H	E	A	T		L	I	M	I	T		
1B		R	E	D	U	C	E	D			F	L	A	M	E	
2	%	%	%	%					@	@	@	@	@	@	@	@

- Your stove is equipped with a heat limit switch which senses a rise in the operating temperature and will reduce the feed rate accordingly. This usually occurs when the stove is in the high burn setting with the convection blower set to minimum (which isn't the most efficient combination). When the stove cools down it will automatically re-enter NORMAL HEATING mode at the setting indicated on the heat control dial.

6 THERMOSTAT OFF - LOW HEAT																		
1A					T	H	E	R	M	O	S	T	A	T		O	F	F
1B								L	O	W		H	E	A	T			
2		S	H	U	T	D	O	W	N		I	N				#	#	#

- The room has reached the temperature specified by the thermostat. When the thermostat quits calling for heat, the stove automatically enters the THERMOSTAT IDLE mode and drops to the low burn setting. If the thermostat does not call for heat again within the next hour, the stove will enter the COOL DOWN mode, followed by the SHUTDOWN mode. If the thermostat calls for heat at any point in the thermostat idle mode, the stove will resume operation in the NORMAL BURN mode specified by the heat control dial.

LCD Display Screen - Cool-down Screens

7 HEAT SWITCH OFF COOL-DOWN																		
1A					C	O	O	L	I	N	G		D	O	W	N		
1B					C	O	O	L	I	N	G		D	O	W	N		
2	%	%	%	%												O	F	F

- You have turned your stove off and the auger has stopped feeding pellets to the Burn-Pot. Once the unit runs through the HEAT SWITCH OFF COOL-DOWN mode, it will go into HEAT SWITCH OFF SHUTDOWN mode.

8 THERMOSTAT OFF COOL-DOWN																
1A			C	O	O	L	I	N	G		D	O	W	N		
1B		T	H	E	R	M	O	S	T	A	T		O	F	F	
2	%	%	%	%										O	F	F

8. The thermostat has not called for heat for over an hour, the stove has completed it's thermostat low burn idle and has entered into the COOL DOWN mode which will be followed by the FINAL SHUTDOWN mode. If the thermostat calls for heat again during this sequence, the stove will automatically enter the START-UP mode.

9 AIR SEAL COOL-DOWN																
1A			C	O	O	L	I	N	G		D	O	W	N		
1B		A	I	R		S	E	A	L			L	O	S	T	
2						E	R	R	O	R						

9. This error occurs when the stove has lost vacuum. This could be from an open glass door, damaged or dislodged gaskets or door seal, a sustained strong gust of wind into the venting/chimney, an electrical "brown out," failed combustion blower or failed vacuum switch.

10 HOPPER OPEN COOL-DOWN																	
1A			C	O	O	L	I	N	G		D	O	W	N			
1B		H	O	P	P	E	R		L	E	F	T		O	P	E	N
2						E	R	R	O	R							

10. The hopper lid has been left open too long or isn't fully closed. To clear the error, make sure hopper lid is closed then reset the stove by turning the heat control dial to "Off" then back to your heat setting of choice and the stove will re-enter START-UP mode.

11 AUGER TORQUE COOL-DOWN																
1A			C	O	O	L	I	N	G		D	O	W	N		
1B			A	U	G	E	R		J	A	M	M	E	D		
2						E	R	R	O	R						

11. The DC brushless auger motor has sensed an over-torque or potential auger jam situation, the automatic reverse sequence has failed to clear the obstruction and the stove has entered into the COOL DOWN mode and will continue into the SHUTDOWN mode.

12 NO FIRE COOL-DOWN																	
1A			C	O	O	L	I	N	G		D	O	W	N			
1B		N	O		F	I	R	E		D	E	T	E	C	T	E	D
2						E	R	R	O	R							

12. Your stove's proof of fire switch has failed to detect fire and has entered into COOL DOWN mode.

LCD Display Screen - Cold Shutdown Screens

13 HEAT SWITCH OFF SHUTDOWN																	
1A			S	H	U	T	T	I	N	G			D	O	W	N	
1B			S	H	U	T	T	I	N	G			D	O	W	N	
2			O	F	F		I	N			#	#		M	I	N	

13. The heat control dial has been turned to the "Off" position, the stove has completed it's cool down sequence, all snap switches register cold. The SHUTDOWN mode is a timed sequence, when complete all blowers, auger etc. will be turned off.

14 THERMOSTAT OFF SHUTDOWN																	
1A			S	H	U	T	T	I	N	G			D	O	W	N	
1B			T	H	E	R	M	O	S	T	A	T		O	F	F	
2			O	F	F		I	N			#	#		M	I	N	

14. Your stove has completed the THERMOSTAT IDLE, and THERMOSTAT COOL DOWN modes, the thermostat still hasn't called for heat again and the stove has entered into it's final shutdown sequence.

15 OVERHEAT SHUTDOWN																	
1A			S	H	U	T	T	I	N	G			D	O	W	N	
1B		S	T	O	V	E		O	V	E	R	H	E	A	T	E	D
2						E	R	R	O	R							

15. The high limit snap switch has been activated due to excessive heat or a failed component and the stove is in it's final shut down sequence. Contact your dealer.

16 AIR SEAL SHUTDOWN																	
1A			S	H	U	T	T	I	N	G			D	O	W	N	
1B			A	I	R		S	E	A	L			L	O	S	T	
2			O	F	F		I	N			#	#		M	I	N	

16. Your stove has lost vacuum, completed it's air seal cool down sequence and has entered the FINAL SHUTDOWN mode. Refer to screen #9 for list of possible causes. Turn heat control dial to "off" and then back on to restart.

17 HOPPER OPEN SHUTDOWN																	
1A			S	H	U	T	T	I	N	G			D	O	W	N	
1B		H	O	P	P	E	R		L	E	F	T		O	P	E	N
2			O	F	F		I	N			#	#		M	I	N	

17. The hopper lid has been left open too long or isn't fully closed. To clear the error, make sure hopper lid is closed then reset the stove by turning the heat control dial to "Off" then back to your heat setting of choice and the stove will re-enter START-UP mode.

19 AUGER TORQUE SHUTDOWN																	
1A			S	H	U	T	T	I	N	G			D	O	W	N	
1B				A	U	G	E	R		J	A	M	M	E	D		
2			O	F	F		I	N			#	#		M	I	N	

18. The stove was unable to clear an obstruction in the auger or drop tube and is in the process of shutting down.

19 NO FIRE SHUTDOWN																
1A	S	H	U	T	T	I	N	G			D	O	W	N		
1B	N	O		F	I	R	E		D	E	T	E	C	T	E	D
2	O	F	F		I	N		#	#		M	I	N			

19. Your stove's proof of fire switch has failed to detect fire, the stove has completed it's COOL DOWN mode and is in the process of shutting down.

LCD Display Screen - Off Mode Screens

20 HEAT SWITCH OFF																
1A				S	T	O	V	E			O	F	F			
1B				S	T	O	V	E			O	F	F			
2	O	F	F										O	F	F	

20. Your stove's heat control dial is in the off position and all loads are currently off.

21 THERMOSTAT OFF																
1A	T	H	E	R	M	O	S	T	A	T		O	F	F		
1B	T	H	E	R	M	O	S	T	A	T		O	F	F		
2	O	F	F										O	F	F	

21. The thermostat is not calling for heat, the stove is off.
NOTE: The heat control dial may still be set to the low through high positions, in which case when the thermostat calls for heat again the stove will automatically ignite.

22 OVERHEAT ERROR																
1A	O	V	E	R	H	E	A	T		E	R	R	O	R		
1B	O	V	E	R	H	E	A	T		E	R	R	O	R		
2		O	F	F		T	O		C	L	E	A	R			

22. The high limit snap switch has been activated due to excessive heat or a failed component, The stove has completed it's cool down and shutdown sequences and the stove is currently off. Contact your dealer.

23 AIR SEAL ERROR																
1A	A	I	R		S	E	A	L		E	R	R	O	R		
1B	A	I	R		S	E	A	L		E	R	R	O	R		
2		O	F	F		T	O		C	L	E	A	R			

23. Your stove has lost vacuum, completed it's air seal cool down and shut down sequence and is currently off. Refer to screen #9 for list of possible causes. Turn heat control dial to "Off" and then back on to restart.

24 HOPPER OPEN ERROR																
1A	H	O	P	P	E	R		L	I	D		E	R	R	O	R
1B	H	O	P	P	E	R		L	I	D		E	R	R	O	R
2		O	F	F		T	O		C	L	E	A	R			

24. The hopper lid has been left open too long or isn't fully closed. The stove has completed it's cool down and shut down sequences and is currently off. To clear the error, make sure hopper lid is closed then reset the stove by turning the heat control dial to the "Off" position.

25 AUGER JAM ERROR															
1A	A	U	G	E	R		J	A	M		E	R	R	O	R
1B	A	U	G	E	R		J	A	M		E	R	R	O	R
2		O	F	F		T	O		C	L	E	A	R		

25. The stove was unable to clear an obstruction in the auger or drop tube, the COOL DOWN and SHUT DOWN modes have been completed and the stove is currently off. To clear the error the heat control dial must be turned to the "Off" position although the obstruction will have to be cleared before normal operation can resume. Contact dealer for assistance.

26 NO FIRE ERROR															
1A		N	O		F	I	R	E			E	R	R	O	R
1B		N	O		F	I	R	E			E	R	R	O	R
2		O	F	F		T	O		C	L	E	A	R		

26. Your stove's proof of fire switch has failed to detect fire, the stove has completed it's cool down and shut down sequences and is currently off. To clear error turn heat control dial to the "off" position.

LCD Display Screen - Other Screens

27 OVERHEAT CONTACT DEALER																
1A	O	V	E	R	H	E	A	T		E	R	R	O	R		
1B	O	V	E	R	H	E	A	T		E	R	R	O	R		
2	C	O	N	T	A	C	T		D	E	A	L	E	R		

27. The high limit snap switch has been activated due to excessive heat or a failed component and the stove is currently off. Contact your dealer or service representative. This error can only be cleared by an authorized representative.

28 SOFTWARE VERSION															
1A				C	O	N	T	R	O	L	L	E	R		
1B				C	O	N	T	R	O	L	L	E	R		
2		0	6	0		V	E	R		1	.	0	0		

28. This is the version of software your control board is currently running.

SYMBOL	DEFINITION
\$	Numerical countdown in minutes or seconds
#	Numerical countdown in minutes
%	"OFF", "MIN.", from " 40%" through "100%"; numbers right justified, text left justified
@	"OFF", "LOW", "MED-LOW", "MEDIUM", "MED-HIGH", or "HIGH" right justified text
*	"+" or "-" symbol
!	Numerical error count
?	"OFF", "LOW", "MED-LOW", "MEDIUM", "MED-HIGH", or "HIGH" centered text
=	EEPROM address value
^	"PASSED" or "FAILED"
~	"0% through "100%" right justified
	"0% through "20" right justified
/	"AC" or "DC"
:	Numerical countdown in minutes or "MAX"

Shut Down - Normal - To turn the stove off, turn the heat control dial to off. The blowers will continue to operate until the control board completes the shut down cycle.

Power Outage - If the stove has a momentary electrical power loss of less than ten seconds the stove will continue to operate normally when power resumes. If electrical power is interrupted for more than ten seconds the stove will automatically re-enter the start-up mode provided the heat control dial is still in the "On" position. If the stove is connected to a thermostat, the stove will enter the start-up mode when the thermostat calls for heat.

Paint Curing - Stove components have been painted with a high temperature paint. It leaves the factory dry to the touch, but completes the curing process as the stove is used. The paint will cure during the first few times the stove is burned. Also some parts of the appliance may be lightly coated with machining oil. Ventilate the house during these first firings as the paint and oil give off carbon dioxide and unpleasant odors. It is recommended that persons sensitive to an imbalance in the indoor air quality avoid the stove during the curing process.

Convection Blower Operation - Your Bella™ pellet stove comes equipped with a temperature activated convection blower that extracts heat from the stove. After the stove warms up, a heat activated switch will turn the blower on. The speed of the blower varies with the burn rate of the stove, but the speed is adjustable with the convection blower speed control knob, as well. The blower will continue to extract heat after the stove shuts off and until it is cooled down.

Operating Sounds - As the Bella pellet stove is burning, a number of normal operational sounds may be heard. Pellets can be heard sliding down the auger tube and into the Burn-Pot. Also, the motor powering the auger can be heard as the control board calls for pellets. Occasionally a loud noise can be heard as the auger cuts a pellet in half. When the blowers come on, the sound of rushing air may be heard. The lower the burn rate the slower the blower operates. Hourly, the combustion blower will blow at a high speed to clean ash from the Burn-Pot.

CAUTIONS

INSTALLATION AND REPAIR SHOULD ONLY BE PERFORMED BY A QUALIFIED SERVICE TECHNICIAN. DO NOT ATTEMPT TO SERVICE THE APPLIANCE YOURSELF.

Avoid overfiring the stove - do not hand feed pellets to the appliance.

Never use gasoline, gasoline-type lantern fuel, kerosene, charcoal lighter fluid, or similar liquids to start or fresh up a fire in this heater. Keep all such liquids well away from the heater while it is in use.

For your safety, do not install or operate your Bella pellet stove without first reading and understanding this manual. Any installation or operation of the appliance deviating from that which is stated in this instruction manual WILL void the warranty and may be hazardous.

Due to high temperatures, the stove should be located out of traffic areas and away from furniture and draperies. Children and adults should be alerted to the hazards of high surface temperature and should stay away to avoid burns or clothing ignition. Young children should be carefully supervised when they are in the same room as the Bella pellet stove. Clothing or any other flammable material should not be placed on or near the stove. Any grill, panel, or glass removed for service MUST be replaced prior to operating the stove.

Do not operate appliance with the glass front removed, cracked, or broken. Replacement of the glass should be done by a qualified service technician.

IHP, its employees, or any of its representatives assume no responsibility for any damages caused by an inoperable, inadequate, or unsafe condition as a result of any improper operation, service, or installation procedures, whether direct or indirect.

The appliance, when installed, must be electrically grounded in accordance with local codes or, in the absence of local codes, with the National Electrical Code, ANSI/NFPA 70 - latest edition or the Canadian Electrical Code, CSA C22.1 - latest edition.

FUEL

CAUTION

The use of unapproved, dirty, wet and / or high salt content fuel will void the warranty!

This stove is designed to burn wood pellet fuel. In addition, a corn/wood pellet mixture, with a maximum of 50 percent corn can be burned. Burning any other fuel that is not approved for use with this appliance will void the appliance warranty. **IMPORTANT: The corn/wood mix needs to be mixed evenly before being put in the pellet stove hopper.**

Wood Pellet Specifications

This appliance has been designed to burn wood residue pellets with up to 2% ash content. Dirty fuel will adversely affect the performance of the stove. Any questions regarding pellet fuel can be answered at the Pellet Fuels Institute (PFI), www.pelletheat.org

Pellet fuel is made from sawdust and scrap wood from many different species of wood. Pellets are either 1/4" or 5/16" in diameter and vary in length. The Bella stove will burn either diameter pellets. Pellets made from hardwoods contain more ash than those made from softwoods. Minerals from ash and sand in the pellets form clinkers under the extreme temperatures in the Burn-Pot. Try burning various brands of pellets until you find one that burns with minimum ash and clinkers. Once you find a pellet brand that burns well, continue using this brand. High ash fuel increases the frequency of stove cleaning. Fuel with an excessive moisture content may jam the auger assembly.

Clinkering - Silica (or sand) in the fuel, along with other impurities, can cause clinkering. A clinker is a hard mass of silica formed in the burning process. Clinkering is a function of the fuel, (not the stove), but adversely affects the performance of the stove by blocking off the air passages in the Burn-Pot. Even P.F.I. approved pellet fuel may tend to clinker. See *Routine Maintenance* (on **Pages 26 through 31**) for more information on cleaning.

Ash - The frequency of removal of the ash and maintenance performed on the stove is directly proportional to the ash content of the fuel and the operation duration of your pellet stove. Low ash fuel may allow longer intervals between cleaning, however, a stove burning high ash fuel may need to be cleaned as often as everyday.

Fuel Feed Rates - Different brands of wood pellets will feed at varying rates due to their size and density (length and diameter). This may require a slight adjustment in the draft adjuster (see **Pages 11 and 12**).

PLEASE NOTE: IHP has no control over the manufacturing of wood pellet fuel and will not be held responsible for poor stove performance or any damage caused by poor quality wood pellet fuels.

Pellet Fuel Storage -

- **Store your wood pellets in a dry place to prevent them from absorbing excess moisture.**
- **Do Not store your wood pellets within the clearance zone of the stove.**
- **Do Not store your wood pellets in a place that would block access to refueling the hopper.**

Wood pellets manufactured to the pellet fuels institute (P.F.I.) certification standard are available in two grades, Standard and Premium. The primary difference between the two is the ash content of the pellets.

The P.F.I. specification for standard grade and premium grade residential and commercial pellet fuel is as follows:

- **CHLORIDES (Salt):** Less than 300 p.p.m. to avoid stove and vent rusting.
- **BULK DENSITY:** 38 to 40 lb. / Cu. Ft. minimum
- **MOISTURE CONTENT:** 8% to 10% maximum
- **ASH CONTENT:** < 2% maximum (standard grade) < 1% maximum (premium grade)
- **FINES:** 0.5% to 1% maximum through a 1/8" screen
- **BTU CONTENT:** There are a number of variations in pellet fuels that are not included in PFI standards. For example, BTU (heat value) content may range from just under 8,000 to almost 9,000 BTU, depending upon species and region of the country and other variables.

Corn Fuel Specifications

Use only clean-shelled corn with a moisture content less than 15% and approximate fuel value of 7000 BTU/lb (16,200 kJ/kg). Do not attempt to burn corn with higher moisture content or burn lesser grade fuels. Do not burn other types of agricultural pellets or by-products (alfalfa, cherry pits, olive pits, nut shells, etc.) as they are not permitted to be burned in these appliances.

Shelled corn can be burned in this appliance when it is mixed with wood pellet fuel. The mixture can contain a maximum of 50 percent corn. Burning corn may create more ash than wood pellets and may necessitate the need to clean the Burn-Pot and glass more frequently.

Store corn in a tight container and use methods to ensure the corn does not become rain soaked or absorb moisture from damp or wet sources. This will also prevent rodents from becoming a problem. Do not store corn within stove installation clearances.

NOTES:

- **Corn with excessive grain dust must be screened, by sifting with 3/16" mesh screening. Large pieces of cob may plug the auger.**
- **When changing from burning all wood pellets to burning a corn and wood pellet mix, the draft adjuster may need to be adjusted to achieve proper combustion.**

WARNING

Do not burn treated seed corn! Seed corn is treated with chemical pesticides that are harmful or fatal if swallowed. Burning treated corn will void your warranty!

ROUTINE MAINTENANCE

IMPORTANT CAUTIONS:

- **UNPLUG POWER CORD AND ENSURE APPLIANCE IS COLD BEFORE PERFORMING ANY MAINTENANCE WORK.**
- **Some brands of pellets produce more ash and clinkers than others. Therefore the frequency of performing the following cleaning procedures depends to a great degree on the quality of the pellets burned.**
- **Not cleaning this unit will cause it to burn poorly and will void your warranty for this appliance.**
- **When removing ash build-up, use an approved ash vacuum only. A cleaning brush can be used to loosen any ash build-up before vacuuming. DO NOT USE A STANDARD HOUSEHOLD VACUUM OR "SHOP VAC" AS THE FILTERS WILL LEAK THE FINE PARTICLES OF ASH INTO THE HOME.**
- **THIS WOOD HEATER NEEDS PERIODIC INSPECTION AND REPAIR FOR PROPER OPERATION. IT IS AGAINST FEDERAL REGULATIONS TO OPERATE THIS WOOD HEATER IN A MANNER INCONSISTENT WITH OPERATING INSTRUCTIONS IN THIS MANUAL.**

Required Cleaning Schedule After Number Of Bags Burned:

Burn-Pot = 10 bags
Ash Pots = 20 bags
Flue Passageways = 50 bags
Combustion Blower = 100 bags
Convection Blower = 100 bags

NOTES:

- **Cleaning schedule will vary depending on quality of pellets used. Burning high ash pellets will require more frequent cleaning.**
- **Using a drop cloth is recommended as some ash may spill onto the floor during the cleaning process.**

Opening the Glass Door

CAUTION: Do not open the front door when the stove is hot. To open the glass door, first you must open the front cast iron door. Facing the front of the stove gently pull the far left edge of the door towards you, the front cast iron door will open about 90 degrees to uncover the door sealing the firebox (see **Figure 31**). Once the front cast iron door is open, locate the door latch handle (B in **Figure 31**) and pull towards you which will release the seal to the firebox and allow you to gain access to the Burn-Pot and ash pots. To close door, repeat these steps in reverse order.

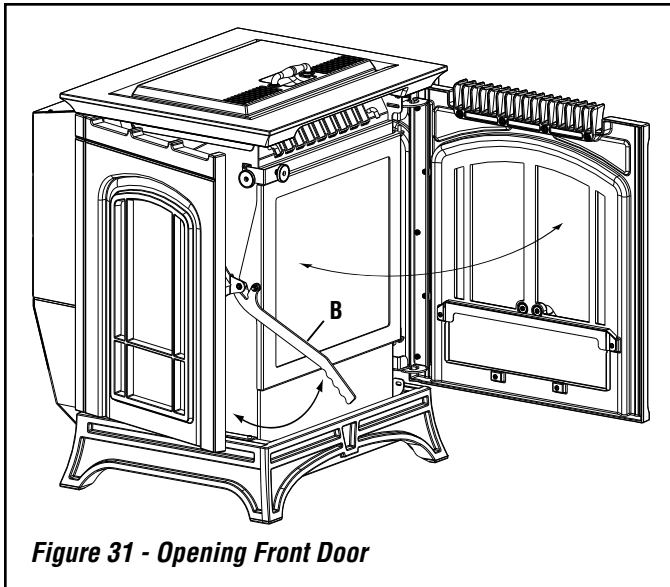

Figure 31 - Opening Front Door

Opening Right Side Door

Unlike the front and left side doors which are held in the closed position by magnets, the right side door is fastened from the inside to assure there is no interference when opening the front door. **CAUTION; read and understand the steps below and open the right side door with care. Not following these steps could result in damage to the enamel or painted surface of the front or side doors.**

To open the right side door:

1. Open the front cast iron door.
2. Locate the two right side door retaining screws shown in **Figure 32**.
3. Remove the two screws from the right side door. **NOTE: the screws do not have to be completely removed from the stove body, only the right side door.**
4. Hold the right side door closed tightly while you carefully return the front cast iron door to the closed position paying special attention to the narrow gap between the two doors.
5. Once the front cast iron door is in the closed position, the right side door can be opened.
6. When maintenance is complete, be sure to re-fasten the right side door by repeating steps.

To close the right side door:

1. Make sure the front cast iron door is fully closed.
2. Close right door.
3. Hold right door closed tightly while carefully opening the front door again to gain access to the screws.
4. Re-secure right side door by tightening the two screws shown in **Figure 32**.
5. Check the clearance between the front and side doors by slowly opening the front door while visually checking the gap between the two panels. If the two touch, it may be necessary to tighten the right side door retaining screws.

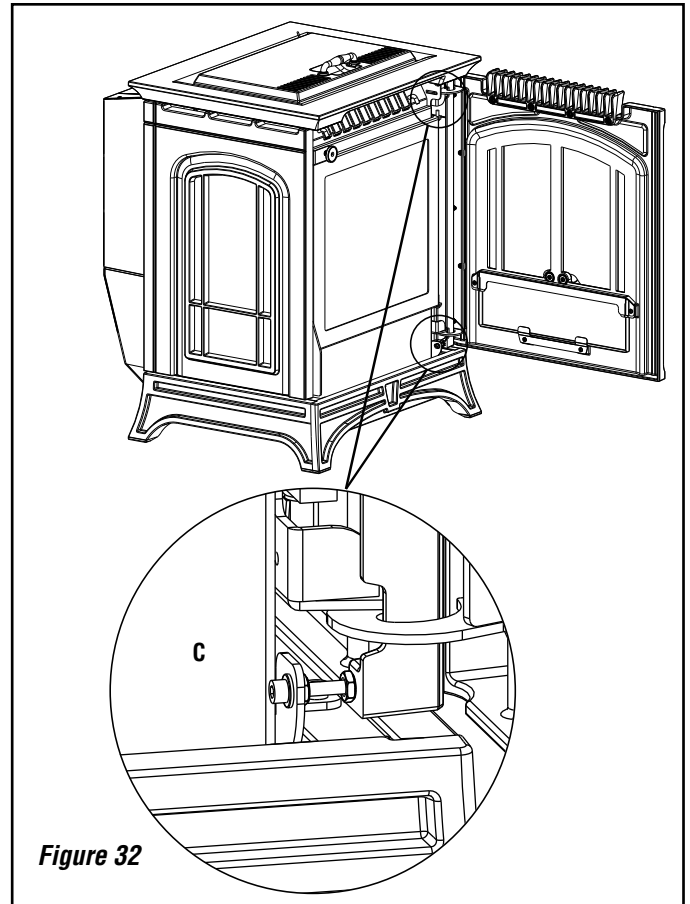

Figure 32

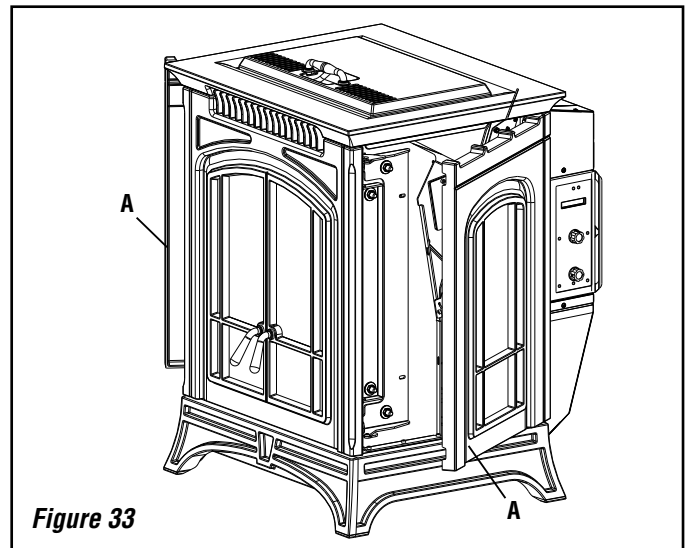
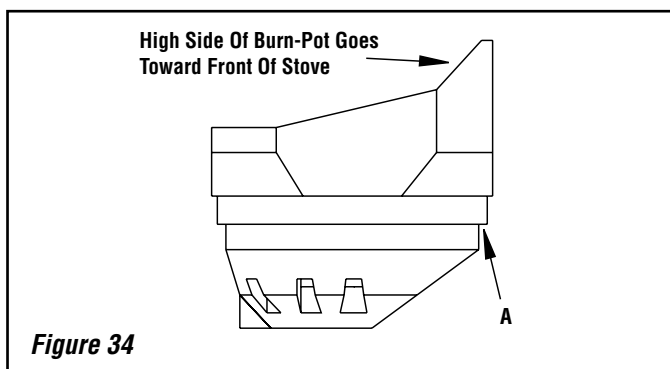

Figure 33

Burn-Pot Cleaning

(Recommended Frequency of 1 – 2 days*)

The combustion blower comes on at high speed once an hour to blow the by-products of combustion out of the Burn-Pot. However, the Burn-Pot should be cleaned more thoroughly after burning about 10 bags of pellets. The Burn-Pot has a number of holes in the bottom and sides that provide combustion air to the pellets. The extreme temperatures in the Burn-Pot can cause the impurities in the pellets to form ash and clinkers. When the stove is cool, open the front door and lift out the cast iron Burn-Pot. Scrape the inner bottom and sides of the pot with a screwdriver to remove all ash and clinkers from these surfaces. Make sure all the holes in the pot are open. Place the Burn-Pot in the hole from which it was removed. Make sure the high side of the pot is rotated toward the front of the stove (see **Figure 34**). Push the Burn-Pot down so surface A is tight against the steel supporting the pot. Do not substitute any other grate or pot for use in this stove.



Cleaning Glass

DO NOT CLEAN THE GLASS WHEN THE STOVE IS HOT.

CAUTION: Do not open the front door when the stove is hot. Follow the steps listed on **Page 26** for opening the glass door. Clean the glass using a soft cloth or paper towel and a household glass cleaner or gas stove window cleaner. A commercial glass cleaner designed for stoves is recommended. Do not use abrasive cleaners. A damp cloth with a small amount of ash from the firebox can also be used to clean the glass.

Servicing Glass

CAUTION: BE CAREFUL NOT TO ABUSE THE DOOR ASSEMBLY BY STRIKING OR SLAMMING IT. IF THE DOOR ASSEMBLY OR GLASS IS BROKEN OR DAMAGED, THEY MUST BE REPLACED BEFORE HEATER CAN BE SAFELY OPERATED. USE ONLY COMPONENTS PROVIDED BY THE MANUFACTURER AS REPLACEMENT PARTS.

Replacing Glass:

1. Remove door from stove by lifting door up and off hinge pins: Place door on a protected (towel) clean flat surface with the inside of the door facing up. First, remove the door rope and the 12 hex nuts fastening the glass retainers. Then carefully remove broken glass one piece at a time (protective gloves are recommended).
2. Clean area where the glass with gasket will be installed.
3. Install new glass with gasket (use only factory 5 mm glass with glass channel gasket. Do not substitute). Carefully reinstall glass retainers. Be very careful not to overtighten hex nuts.
4. Install new door seal.
5. Reinstall door and adjust door latch and hinge if necessary for proper seal.

Ash Pots Removal and Cleaning

(Recommended Frequency of 2 Days - 2 Weeks*)

NOTE: If an optional log set is installed, carefully remove logs before removing ash pots. Great care should be used in handling logs to prevent damage. To ensure the longevity of the log assembly, never attempt to handle logs while hot. Use an all-purpose brush to periodically remove fly ash build-up from the log assembly. By using the decorative log set, the maintenance frequency for ash removal and cleaning of the glass may need to be increased.

CAUTION: Do not remove the ash pots when the stove is hot. To remove the ash pots, rotate open front casting and then front door (as explained on **Page 26**). Gloves are recommended when reaching inside the firebox to lift ash pots up and out of firebox. When ash pots are free of ash and cleaned, replace in the appropriate sides making sure the pots are fully seated to the bottom of the firebox. Once in place, close and latch the glass door and close the front cast iron door (see **Figure 35**).

CAUTION: Disposal of Ashes - Ashes should be placed in a steel container with a tight fitting lid and moved outdoors immediately. The closed container should be placed on a non-combustible floor or the ground - well away from all combustible materials, pending final disposal. If the ashes are disposed of by burial in soil or otherwise locally dispersed, they should be retained in the closed container until all cinders have been thoroughly cooled.

Reinstall the ash pots by placing them in the left and right bottom of firebox making sure they are seated on the bottom of the firebox. Note that if the ash pots do not seal tightly to the stove, the control board may detect a leak and shut the stove down.

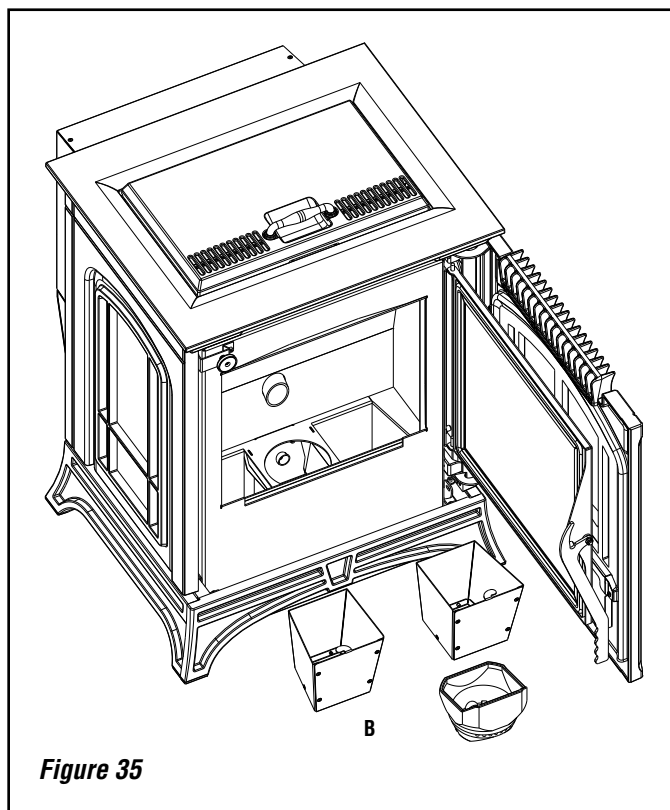

***Burning fuel with a high ash content or an improperly adjusted damper may require more frequent cleaning and stove maintenance.**

Inspect Gaskets

(Recommended Frequency of Yearly*)

Inspect the condition of the rope gasket around the door and window periodically, and replace if necessary.

Cleaning the Heat Exchanger

(Recommended Frequency of 2 Days - 2 Weeks*)

CAUTION: Do not operate the heat exchange scraper when the stove is hot. The heat exchange scrapers are located to both the right and left sides of the heat exchanger directly above the glass door (see **Figure 38**). To remove ash build-up and maintain efficient heat extraction from the stove, the two rods attached to the scraper should be pulled back and forth with even pressure at least once a week. Be sure to make sure the rods and scraper are seated all the way back down before you close the front cast iron door.



WARNING

DO NOT USE BRUSH ON HOT STOVE

Flue Passageways Cleaning Procedure

(Recommended Frequency of Twice Yearly*)

1. Open both the right and left side castings to locate flue clean-out covers (see A in **Figure 36** along with B and C in **Figure 37**).
2. There is one flue clean-out cover on the right side (see A in **Figure 36**) and one lower and upper passageway on the left side (see B and C in **Figure 37**).
3. Using a 5/32" allen remove allen head screws on each cover to access the flue passageway cavities.
4. Using an ash vacuum, clean out all flue passageways on both the left and right side of the stove starting at the top then going to the lowers.
5. Check flue clean-out cover gaskets for any damage and replace if necessary.
6. Once the flue passageways are clear of ash build-up, reinstall the three cover plates.

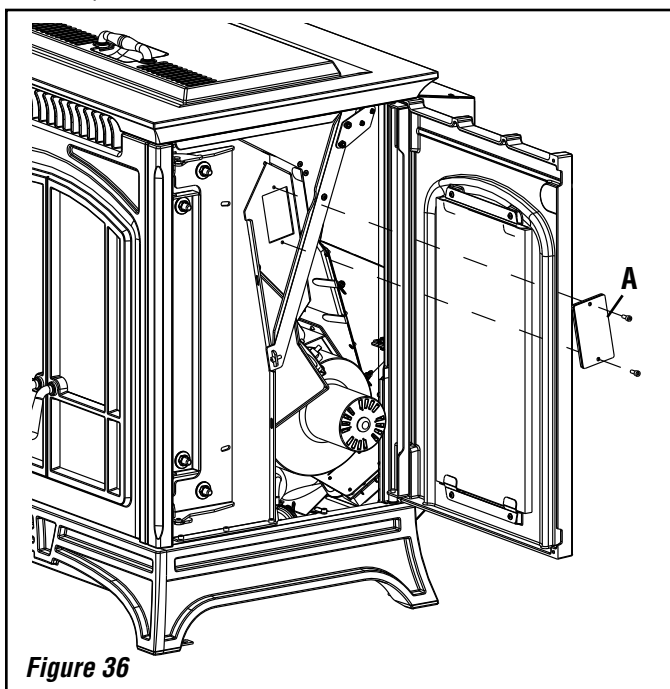

Figure 36

***Burning fuel with a high ash content or an improperly adjusted damper may require more frequent cleaning and stove maintenance.**

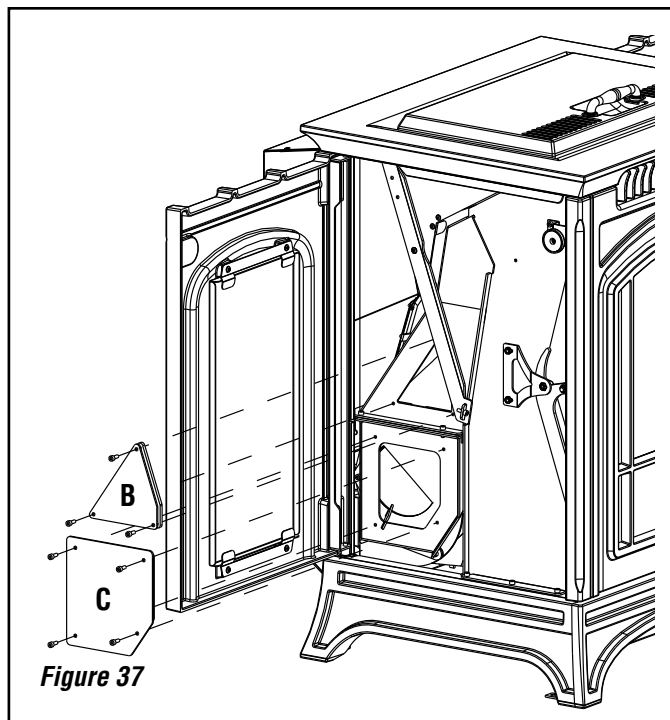

Figure 37

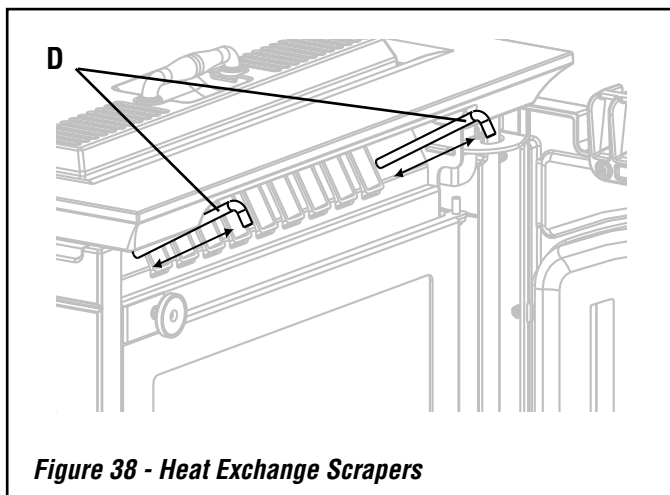

Figure 38 - Heat Exchange Scrapers

Cleaning the Combustion Blower and Proof of Fire Switch

(Recommended Frequency of 1 year or after every 100 bags of fuel used*)

To clean the combustion blower, begin by unplugging the stove, opening the left side door and locating the combustion box clean-out cover in the lower left corner of the stove (C in **Figure 37**). Using a 5/32" allen wrench remove the four screws securing the cover. Once the cover is off, gently brush off the blades as well as the Proof of Fire switch (the small circular object just behind the blades near the bottom. **Figure 39**) and vacuum out all loose ash. When clean, inspect the silicone foam gasket on the cover for damage, replace if necessary and reinstall the cover being sure to tighten the bolts down evenly.

NOTE: Failure to clean the proof of fire switch when needed may result in nuisance shut-downs. When heavy ash, creosote or soot are built up on the proof of fire switch, it may require cleaning with a medium abrasive pad or sheet. These heavy build ups insulate the heat sensing area of the switch and keep the switch from functioning as intended.

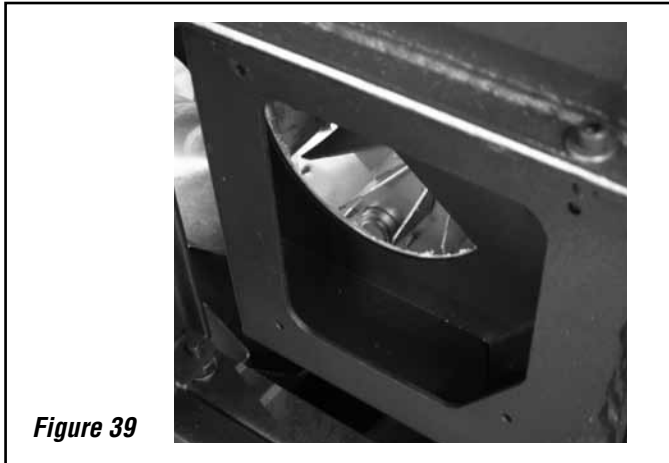

Figure 39

Rear Cover Removal

There are three removable covers on the rear of the stove. For normal maintenance, the lower main cover (**Figure 40**) should yield sufficient access to all necessary components. It may be necessary to remove the lower side and bottom covers for the initial installation.

Removing the Lower Main Cover:

1. Unplug stove.
2. Locate the cover (**Figure 40**), using a 5/32" allen wrench, loosen the two screws on the bottom of the panel (it is not necessary to completely remove them).
3. Using an 1/8" allen wrench, remove the six screws attaching the top and right (next to the flue) sides of the cover.
4. Remove by pulling the cover directly back just far enough to clear the cast iron side door, and then out.
5. Reverse steps to reinstall.

Removing the side cover:

1. Locate the side cover in the left rear portion of the stove (**Figure 41**) near the combustion blower and flue.
2. Using an 1/8" allen wrench, remove the 3 screws attaching the cover.
3. Remove cover.

Removing the bottom cover:

1. Locate the bottom cover (**Figure 41**) underneath the flue and air intake.
2. Using an 1/8" allen remove the three screws fastening the bottom cover to the stove base and lower main cover.
3. Using a 5/32" allen wrench loosen the two screws on the bottom edge of the cover. **NOTE:** It may be necessary to loosen the two screws which attach the lower side cover to the base as well.
4. Remove bottom cover.
5. To reinstall, repeat steps in reverse order.

Rear Stove Compartment

(Recommended Frequency of Yearly*)

The rear stove compartment should be cleaned periodically (a minimum of once a year). **DISCONNECT ELECTRICAL CORD PRIOR TO CLEANING STOVE.** Any household dust, pet hair or sawdust should be vacuumed or wiped out of the rear compartment of the stove, room air blower, and combustion blower (paying special attention to vacuuming out the intakes of both blowers). The electrical components should be wiped clean.

***Burning fuel with a high ash content or an improperly adjusted damper may require more frequent cleaning and stove maintenance.**

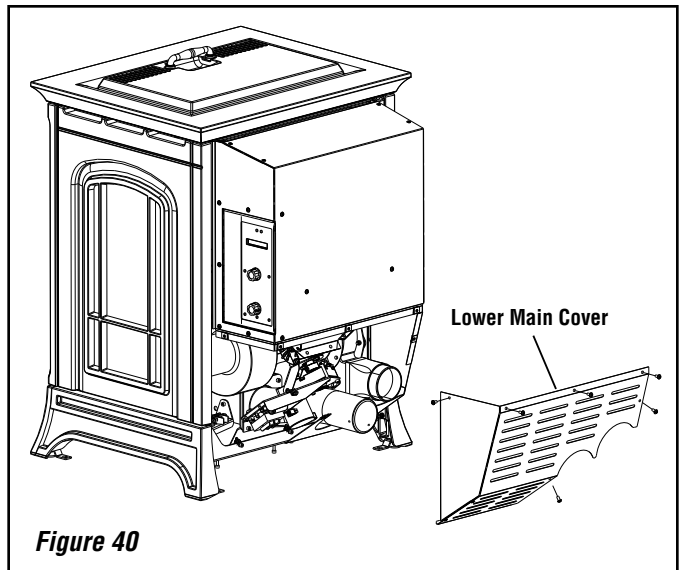

Figure 40

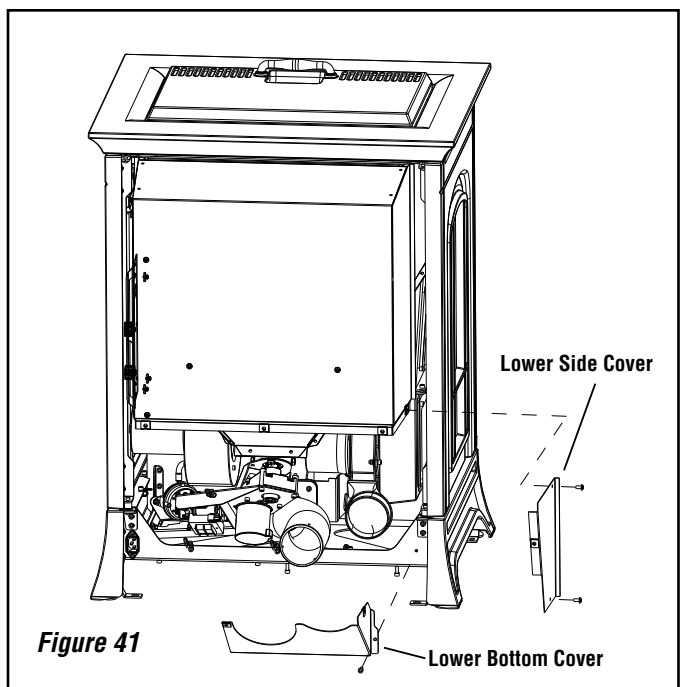

Figure 41

Cleaning the Vent Pipe

(Recommended Frequency of Yearly*)

Soot and Fly-Ash: Formation and Need for Removal - The products of combustion will contain small particles of fly-ash. The fly-ash will collect in the exhaust venting system and restrict the flow of the flue gases. Incomplete combustion, such as occurs during start-up, shutdown, or incorrect operation of the room heater will lead to some soot formation which will collect in the exhaust venting system. The exhaust venting system should be inspected at least once every year to determine if cleaning is necessary. Inspect frequently and clean when necessary. Fly-Ash will accumulate at all bends in the exhaust system. Sweep the pipe as needed. A tee and clean-out in the vent system attached to the stove's flue collar will facilitate this cleaning.

Large amounts of fly-ash build-up will create a lack of combustion air. Removing the clean-out tee cap on vertical installations will allow an inspection of the ash build-up in the clean-out tee and will help you to decide how frequently more extensive cleaning must be performed.

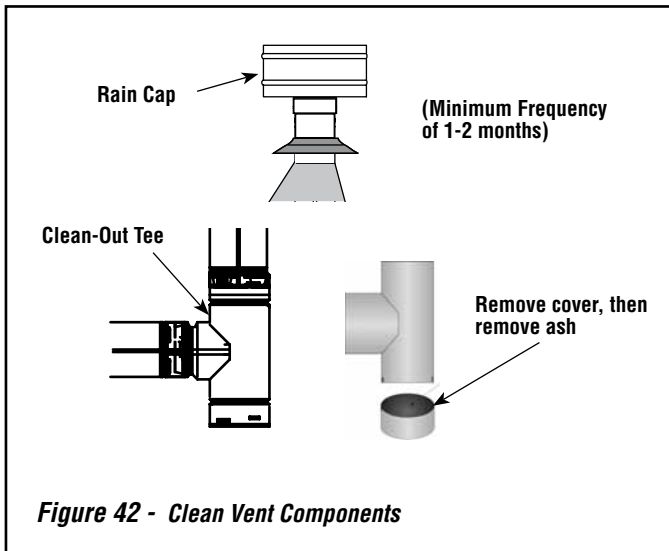

Figure 42 - Clean Vent Components

Cleaning the Convection Blower
(Recommended Frequency of Yearly*)

To clean the convection (room air) blower, disconnect the stove power cord from the electrical outlet. Open the right side door (see **Page 27**). Remove the two nuts (A in **Figure 43**) securing the blower to the blower duct. Slide the blower to the rear, disengaging it from the blower duct. A vacuum can be used to remove any dust accumulation on the blower's blades or inside the blower duct. **Caution should be used not to damage the blower's blades during cleaning.**

To reinstall the blower, slide the blower back into the retaining lip (B) and reinstall nuts (A) making sure the gasket is aligned properly.

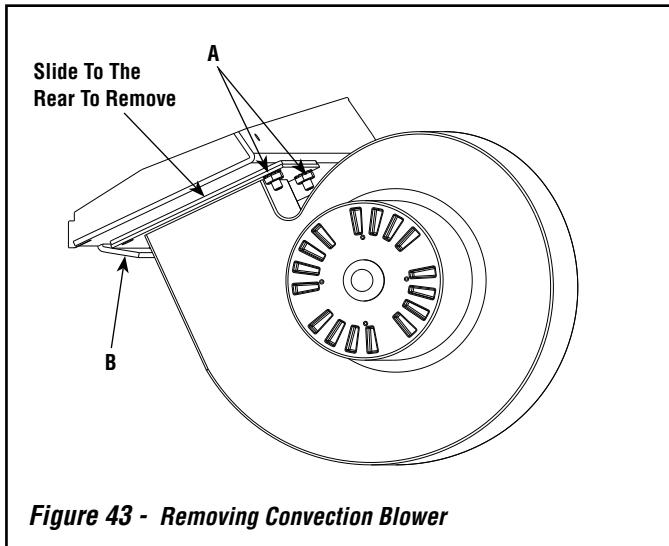

Figure 43 - Removing Convection Blower

***Burning fuel with a high ash content or an improperly adjusted damper may require more frequent cleaning and stove maintenance.**

Small Area Touch-up Paint
Models with Black Painted Finish

The stove body is painted with a quality high-temperature stove paint. Use only stove touch-up paint shown below. Do not touch-up your stove with any other paint.

Cat. No. H8159 Touch Up Paint, Metallic Black

Using one small piece of 320 grit sand paper and lightly sand the blemish so that the edges are "feathered" or smooth to the touch between the painted and bare surfaces. Do not let the sand paper gum up with paint, as this will cause scratches on the metal surface. If there are any scratches, use 600 grit sandpaper instead. Mask off surfaces you do not want painted. Paint lightly over the bare surface first as this will act as an undercoat. Then paint over a larger area in smooth even strokes to blend.

Motor Lubrication

The blowers are permanently lubricated by the manufacturer. Do not apply oil to any part of the blower, doing so may cause damage.

SPECIFICATIONS - Bella™

Product Reference Information				
Cat. No.	Model	Description	Ship. Weight	Ship. Volume
H3480	BELLA-B	Bella, Black Cast	411 lb.	24 cu. ft.
H3481	BELLA-BE	Bella, Espresso Brown	415 lb.	24 cu. ft.

Flue Size	3" (76 mm) Rear
Floor Protection Requirements	Front: 6" (152mm) Sides: 3" (76mm) Back: 0*" (0 mm) ❶
Hopper Capacity	75 Lbs. ❷
Burn time	15-1/2 to 42 hours ❷
Fuse, Control Board Fuse, Igniter	3 Amp, 250 volt, 3AG ❸ 6 Amp, 250 volt ❸
Heat Input (BTU's per hour)	15,300-43,000 BTU/hr ❷
Efficiency Rating	81%
Emissions	1.01 gr/hr, EPA Certified

Convection (room air) Blower	150 CFM; .90 Amps, 1650 rpm
Combustion Blower	100 CFM; 1.3 Amps, 3000 rpm
Auger Motor	1.28 RPM; .4 Amps
Standard Features	Self Igniter

NOTES:

- Dimensions shown are approximations only (+/- 1/4")
- Approved for Manufactured Home Installations.
- Optional kits available - Stone Panel Kits, Brick Panel Kits, Log Set, Leg Leveling Kit, Remote Control and Wall Thermostat.

- ❶ In Canada floor protection is required directly underneath and 2" from the sides of the flue or chimney adaptor. Recommended in the US.
- ❷ Burn times, hopper capacity and BTU input may vary depending on the size and type of fuel used.
- ❸ Fuses are rated as fast acting.

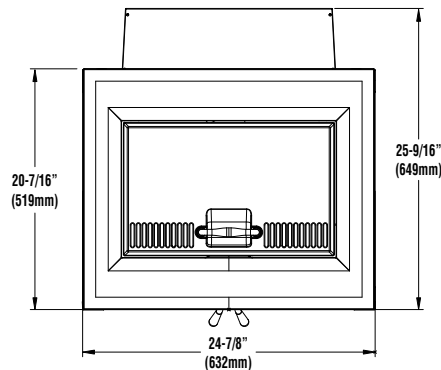
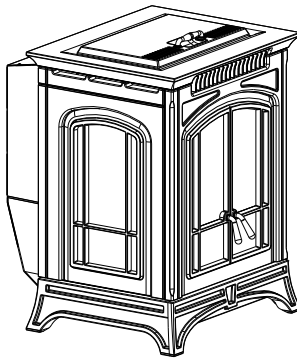

Top View

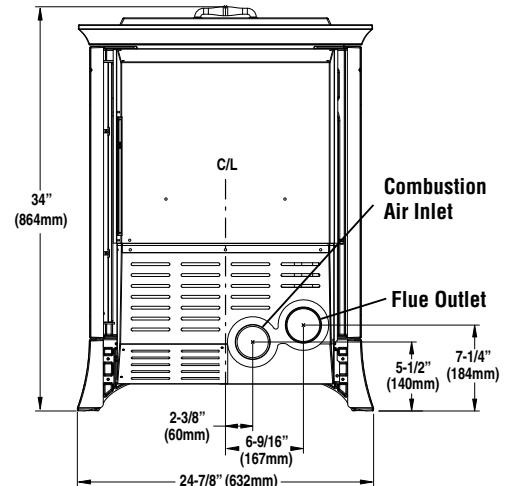

Back View

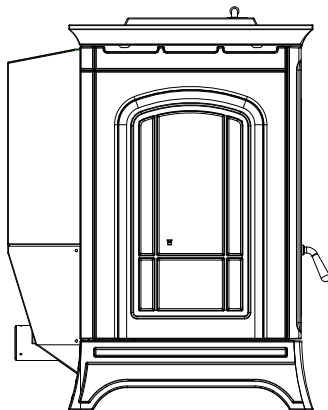

Left Side View

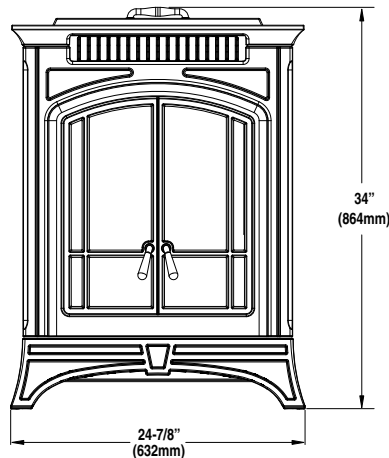

Front View

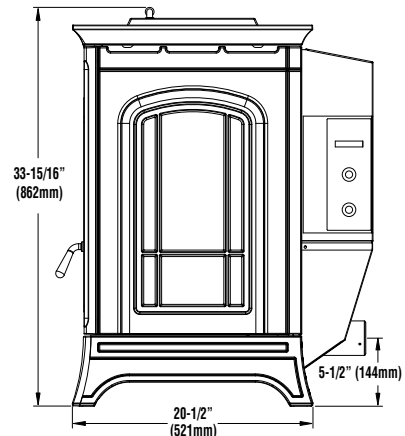

Right Side View

NOTE: DIAGRAMS & ILLUSTRATIONS ARE NOT TO SCALE

COMPONENT DEFINITIONS

- **Air Wash**

The air wash is a portion of the incoming combustion air that is split off and routed to flow across the inside of the glass door which helps the viewing area stay clean.

- **Auger (A)**

A motor powered screw device that transfers the fuel from the hopper to the feed chute to deliver pellets to the Burn-Pot.

- **Auger Motor (B)**

Drives the auger. Motor specifications are: .4 Amp, 1.28 RPM (revolutions per minute). The auger motor turns the auger, lifting pellets up the auger tube. The pellets are then dropped down a tube and into the Burn-Pot. The auger is controlled by the control board.

- **Blower, Convection (Room Air) (C)**

The blower function is to transfer the heat from the appliance to heat the room air.

- **Blower, Combustion (Exhaust) (D)**

It has a radial impeller to deliver more air to the Burn-Pot. It pulls air into the Burn-Pot by creating a negative pressure. This is done by extracting the exhaust gases out of the firebox and pushing the exhaust downstream to the flue exit.

- **Convection Blower Snap Switch (F140-20F, N/O*) (E)**

This switch is located on the snap switch bracket (along with the high limit and pre-high limit snap switches) just inside the right side door on the back of the firebox. When the stove reaches 140° F this switch automatically closes and activates the convection blower. When the stove drops below 120° F the switch opens again turning the convection blower back off.

- **High Limit Snap Switch (Manual Reset) (L225F N/C*) (F)**

This switch is located on the back right of the stove in the snap switch bracket with the convection blower snap switch and pre high limit snap switch. It is designed to shut down the stove if it senses an overfire condition (it opens at 225° F). This snap switch has a reset button on it and will not allow the stove to start-up until the reset button has been pushed.

- **Low Limit Proof of Fire Snap Switch (Ceramic, F140-10F, N/O*) (G)**

This switch is located on the combustion blower. This switch will close at 140° F and will not open until it reaches a temperature of 130° F. It is designed to shut down the stove if it does not detect the heat of a fire at the end of the initial startup period or if your stove has emptied the hopper.

- **Pre High Limit Snap Switch (F200-40F, N/C*) (H)**

This snap switch is N/C and opens at 200° F. It will close when the temperature cools to 160° F. It is located on the back right of the stove in the snap switch bracket with the high limit snap switch and blower snap switch. This switch will slow the feed rate of your auger motor if your convection blower is running at a less than optimal setting and heating up the stove beyond normal heating levels.

- **Hopper Lid Switch (I)**

This switch is located on the upper right rear of the hopper. It detects whether the hopper lid is open and will turn off the auger motor if the hopper lid is not properly closed. When opening the hopper, when refueling, do not allow the hopper lid to remain open too long or the fire may extinguish. **NEVER DISCONNECT OR BYPASS THIS SWITCH FOR ANY REASON.**

- **Hopper (J)**

The hopper is where the pellets are stored.

- **Igniter (K)**

The automatic igniter is designed to light the fuel when the stove is in the lighting mode. The igniter superheats air that is pulled through the Burn-Pot by the combustion blower to light the fuel. The igniter remains energized for the first seven minutes of the lighting sequence.

- **Vacuum Switch (L)**

The vacuum switch located on the right rear of the stove behind the firebox on the vacuum switch bracket. If a low pressure is created in the firebox by a leak, opening the front door, a blocked flue, or unsealed ash pots, the vacuum switch will sense it and cause the stove to go into a shutdown mode.

Some other possible causes for this switch to trip are as follows:

- High altitude or other misc. environmental conditions affecting exhaust flow.
- Improper venting system.

- **Burn-Pot (M)**

This is where combustion occurs.

Electrical Generator Operation

Your Bella™ pellet stove can be powered with a gas driven electrical generator. However, the generator's electrical regulator may not be compatible with the stove's electronics. The higher the quality of the generator, the greater the chance that it is compatible with the stove.

* **N/C = Normally Closed**
N/O = Normally Open

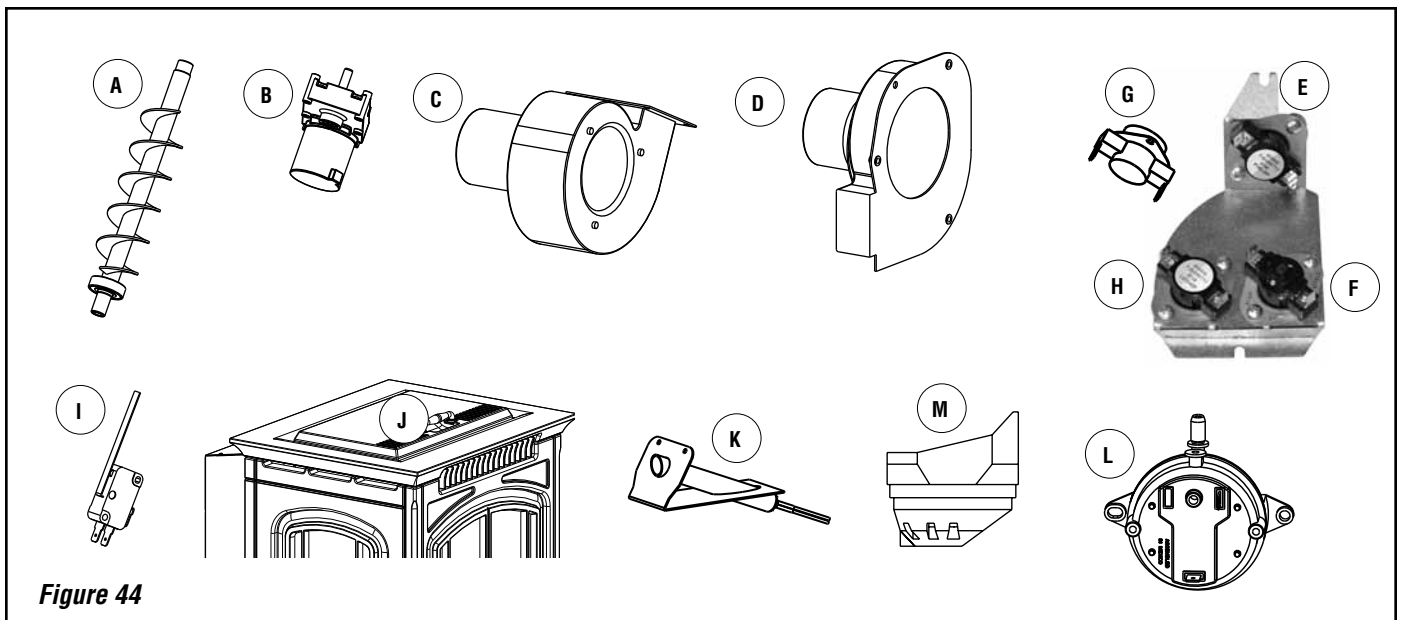
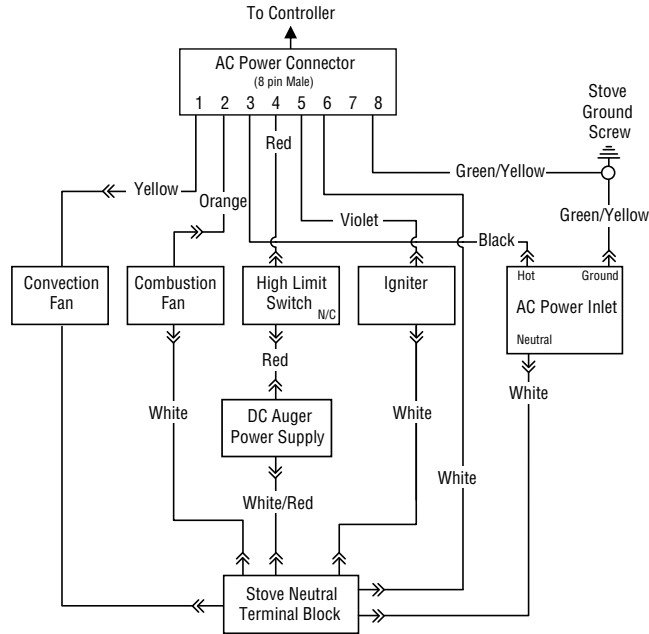

Figure 44

Bella™ Wire Diagram

<- = FEMALE DISCONNECT
 <- = MALE DISCONNECT
 ○ = STUD CONNECTION
 N/C = NORMALLY CLOSED
 N/O = NORMALLY OPEN

Power Wiring Harness - DC Auger



Control Wiring Harness

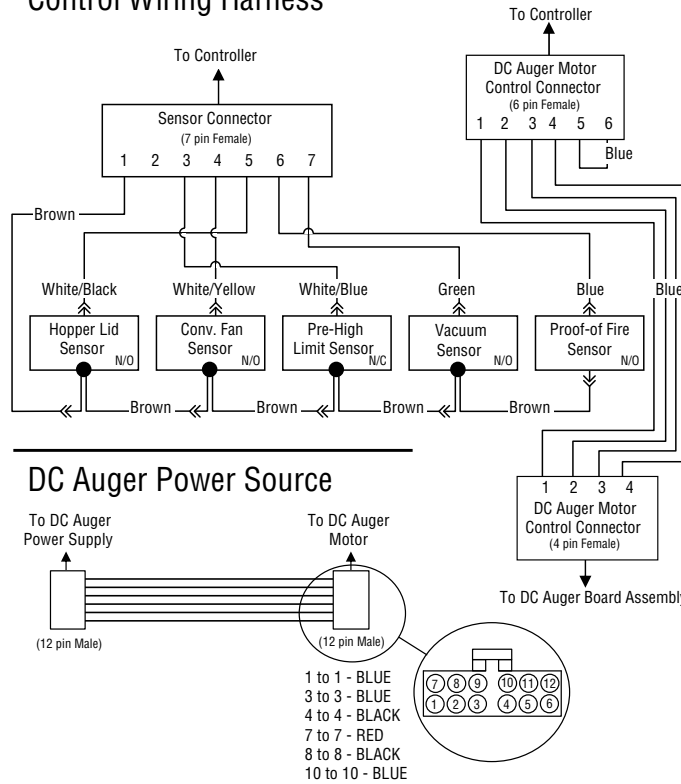

DC Auger Power Source

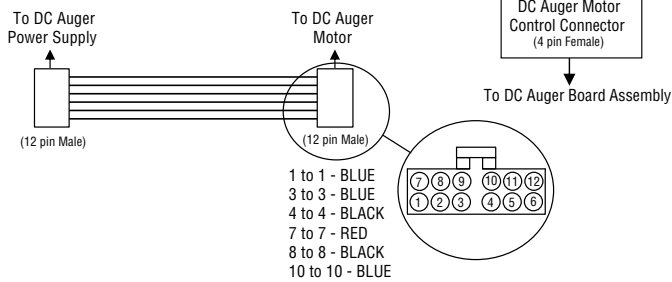

P/N 537176-01 Rev. A

Figure 45 - WIRING DIAGRAM 120 V AC

TROUBLESHOOTING

QUALIFIED TECHNICIANS ONLY

Unplug Appliance Before Performing Any Troubleshooting or Maintenance

Ignition/Proof of Fire Failure - Message - No Fire Error	
Possible Problem	Solution
Hopper is out of pellets	Fill the hopper with pellets
Auger tube was not full of pellets when the start dial was activated	When cool, empty pellets that are in Burn-Pot. Turn ignition/heat control dial off and then back to your desired heat setting.
Burn-Pot dirty - holes plugged	Clean the Burn-Pot making sure all holes are clear of ash and clinkers
Igniter not functioning	Check igniter fuse or replace igniter
Igniter fuse blown	Replace 6 amp fuse located on the side of the controller.
Proof of Fire Snap Switch defective	Replace Proof of Fire Snap Switch
Proof of Fire Snap Switch dirty	Clean Proof of Fire Switch (See instructions on Page 29)

Control Board has no Power - When heat select dial is turned, no lights light up	
Power cord is not plugged in	Plug in power cord
Board fuse blown	Replace 3 amp fuse located on side of control board
Wall outlet not energized	Check circuit breaker panel
Board broken, damaged, or defective	Replace the control board

Vacuum Switch Shuts Stove Down - Message - Air Seal Error	
Front door is not sealing	Latch or adjust the front door. Replace door gasket if worn or damaged
Ash pots are not sealing	Close latches, adjust latches, or replace drawer gaskets
Flue gas passageways restricted	Clean the passageways (see Page 29)
Vent pipe restricted	Clean the vent pipe (see Page 30)
Vacuum hose plugged	Clean or replace the vacuum hose
Vacuum switch defective	Replace the vacuum switch

Proof of Fire Snap Switch Shuts Stove Down - Message - No Fire Error	
Hopper is out of pellets	Fill the hopper with pellets
Snap switch* defective	Replace the "proof of fire" snap switch
"Proof of fire" switch is dirty	Clean switch per instructions on Page 29

TROUBLESHOOTING

QUALIFIED TECHNICIANS ONLY

Unplug Appliance Before Performing Any Troubleshooting or Maintenance

Over Temperature Snap Switch Shuts Stove Down - Message - Overheat Error	
Possible Problem	Solution
Convection blower not running	Blower dirty, blower snap switch bad, or blower broken
Flue passageways or vent restricted	Clean passageways or vent pipe (see Pages 29 and 30)
Snap switch* defective	Replace the snap switch*
* <i>NOTE: The snap switch has a reset button that must be pushed before stove will function (see [F] on Page 33).</i>	

Orange Sooty Flames - Glass turns Black	
Burn-Pot is dirty	Clean the Burn-Pot
Vent pipe restricted	Clean the vent pipe
Flue gas passageways restricted	Clean the passageways
Combustion blower dirty	Clean the combustion blower
Burning improper fuel	Burn only wood pellet fuel or corn fuel that meets the fuel specifications outlined on Pages 25 and 26

Pellets not Feeding	
Hopper empty	Fill the hopper
Auger jammed	Call service technician
Flue gas passageways restricted	Call service technician
Auger motor not operating	Call service technician

REPLACEMENT PARTS LIST - BELLA™

Contact an IHP dealer to obtain any of these parts. Never use substitute materials. Use of non-approved parts can result in poor performance and safety hazards.

CAST IRON REPLACEMENT PARTS		
Item #	Cat. No.	Description
1	H7950	Front Door, Black
1	H7601	Front Door, Brown
2	H7591	Left Door, Black
2	H7602	Left Door, Brown
3	H7592	Right Door, Black
3	H7603	Right Door, Brown
4	H7593	Left Base, Black
4	H7604	Left Base, Brown
5	H7594	Right Base, Black
5	H7605	Right Base, Brown
6	H7595	Front Base, Black
6	H7606	Front Base, Brown
7	H7596	Top Surround, Black
7	H7607	Top Surround, Brown
8	H7597	Hopper Lid, Black
8	H7608	Hopper Lid, Brown
9	H7598	Grill, Black
9	H7609	Grill, Brown
10	H7588	Handle Set, Brushed Nickel, BELLA-HK-BN <i>(ref. Form # 506033-20)</i> ③
11	H7589	Handle Set, Textured Iron, BELLA-HK-TI <i>(ref. Form # 506033-20)</i> ③
CAST IRON MOUNTING BRACKETS		
12	H7646	Front door hinge - base
13	H7647	Front door hinge - door
14	H7645	Left door bracket
15	H7644	Right door bracket
16	H7656	Panel bracket set - side door
17	H7657	Panel bracket set - front
18	H7650	Left door bottom hinge bracket
19	H7649	Right door bottom hinge bracket
20	H7635	Hopper lid hinge assembly
22	H7634	Hopper lid brass latch

GASKETS		
Item #	Cat. No.	Description
23	H7632	Hopper lid gasket ①
24	H7632	Hopper lid handle gasket ①
25	61057203	Convection blower gasket
26	H7633	Combustion blower gasket ②
27	H7631	Combustion chamber gasket (1/4" Ceramex)
28	H7632	Auger to firebox gasket ①
29	H7632	Hopper to auger gasket ①
30	H7633	Intake gasket ②
31	H7632	Gasket flue passageway - upper right ①
32	H7632	Gasket flue passageway cover - upper left ①
33	H7632	Gasket flue passageway cover - lower left ①

① H7632 - 3/16" Silicone Gasket Kit includes the following:

- 1 ea. Hopper lid gasket
- 1 ea. Hopper lid handle gasket
- 1 ea. Auger to firebox gasket
- 1 ea. Hopper to auger gasket
- 1 ea. Gasket flue passageway - upper right
- 1 ea. Gasket flue passageway - upper left
- 1 ea. Gasket flue passageway - lower left

② H7633 - 1/8" Ceramex Gasket Kit includes the following:

- 1 ea. Combustion blower gasket
- 1 ea. Intake gasket

③ Stoves with a brown enamel finish come standard with brush nickel handles and black stoves come with textured iron handles. However, all handles are compatible with stoves regardless of the stove finish, in case handles with a different finish are desired.

REPLACEMENT PARTS LIST - BELLA™

ELECTRICAL		
Item #	Cat. No.	Description
34	H7625	D.C auger motor wiring harness
35	H7624	Controller wiring harness
36	H7623	Power wiring harness
37	H7618	Neutral bus
38	H5889	Vacuum switch
39	H7630	Vacuum switch hose
40	H5891	High limit snap switch (manual reset)
41	H7628	Pre High Limit Snap Switch
42	H5875	Convection blower snap switch
43	H5887	Low Limit Proof of Fire Snap Switch
44	H7386	Power receptacle
45	H7620	Hopper lid switch
46	H7622	DC auger motor
47	H7627	Transformer
48	H7619	Convection blower
49	H7621	Combustion blower
50	H7637	Igniter assembly
51	H7626	Control board
52	79020	Fuse 3 amp (5 per pkg.)
53	79021	Fuse 6 amp (5 per pkg.)

MISC.		
Item #	Cat. No.	Description
54	H5856	Cast Iron Burn-Pot
55	H7617	Cast intake tube
56	H7639	Vinyl coated wire retainer (9 per pkg.)
57	H7629	Brass vacuum nipple
58	H7616	Snap switch bracket
59	H7611	Flue passageway cover - upper right
60	H7613	Flue passageway cover - upper left
61	H7612	Flue passageway cover - lower left
62	H7641	Door latch access plug and latch
63	H7610	Glass Door handle
64	H7642	Firebox door with glass
65	H7648	Firebox door hinge base
66	H7643	Magnet Assembly
67	H7658	Brick panel bracket kit
68	H7659	Sheet metal panel kit (left, right and front panels)
69	H7636	Auger shaft with lower bearing
70	H7640	Auger shaft collar
71	H7651	Ash pot left
72	H7652	Ash pot right
73	H7653	Control board box
74	H5147	Horizontal pipe adaptor
75	H7614	Hopper Cover Corner
76	H7615	Hopper Cover Side
77	H7654	Hopper Cover Top
78	H7655	Hopper Cover Bottom
79	H7665	Leg Bolt Down Kit, Manufactured Homes

REPLACEMENT PARTS DIAGRAMS

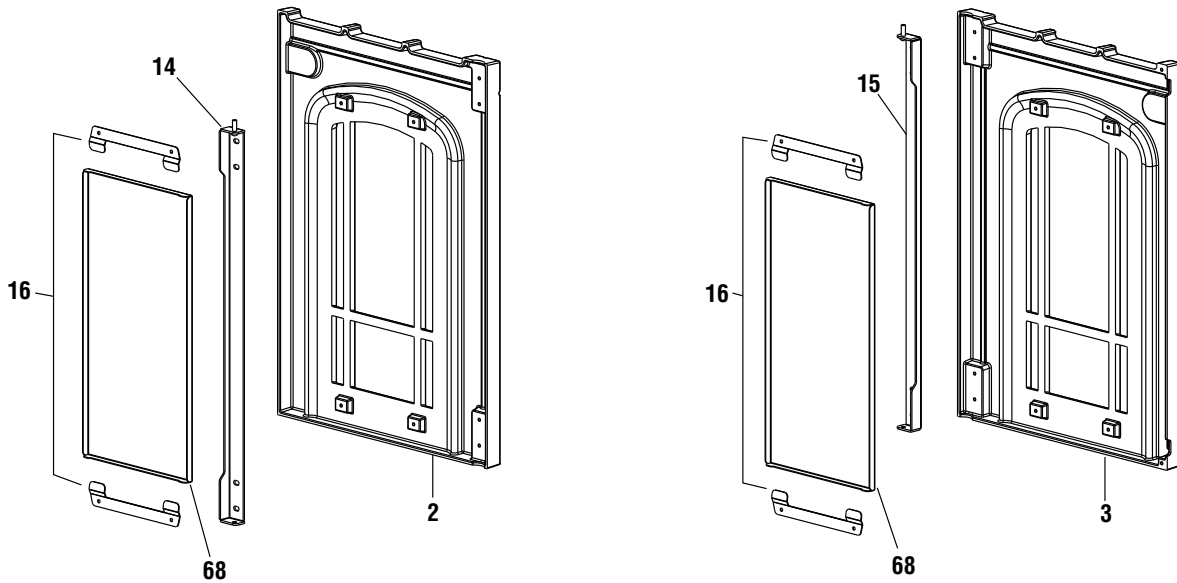
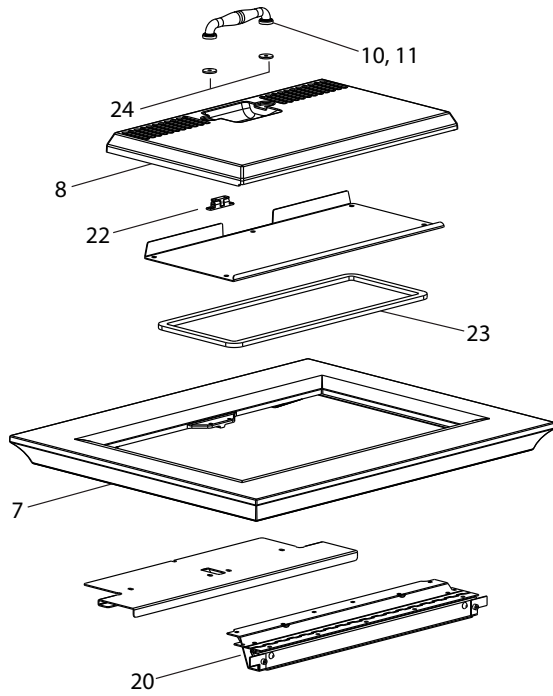

NOTE: DIAGRAMS & ILLUSTRATIONS ARE NOT TO SCALE

REPLACEMENT PARTS DIAGRAMS

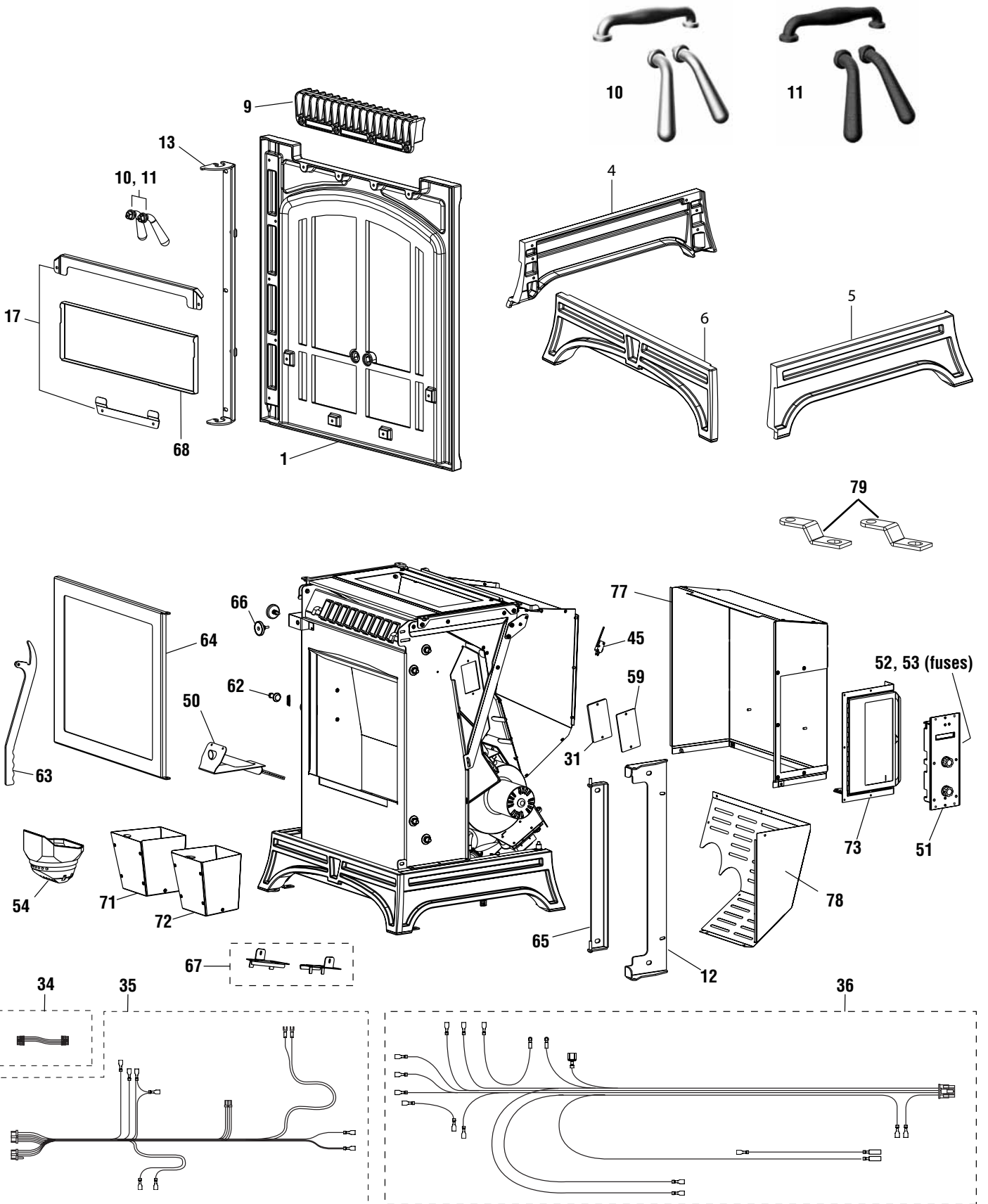

REPLACEMENT PARTS DIAGRAMS

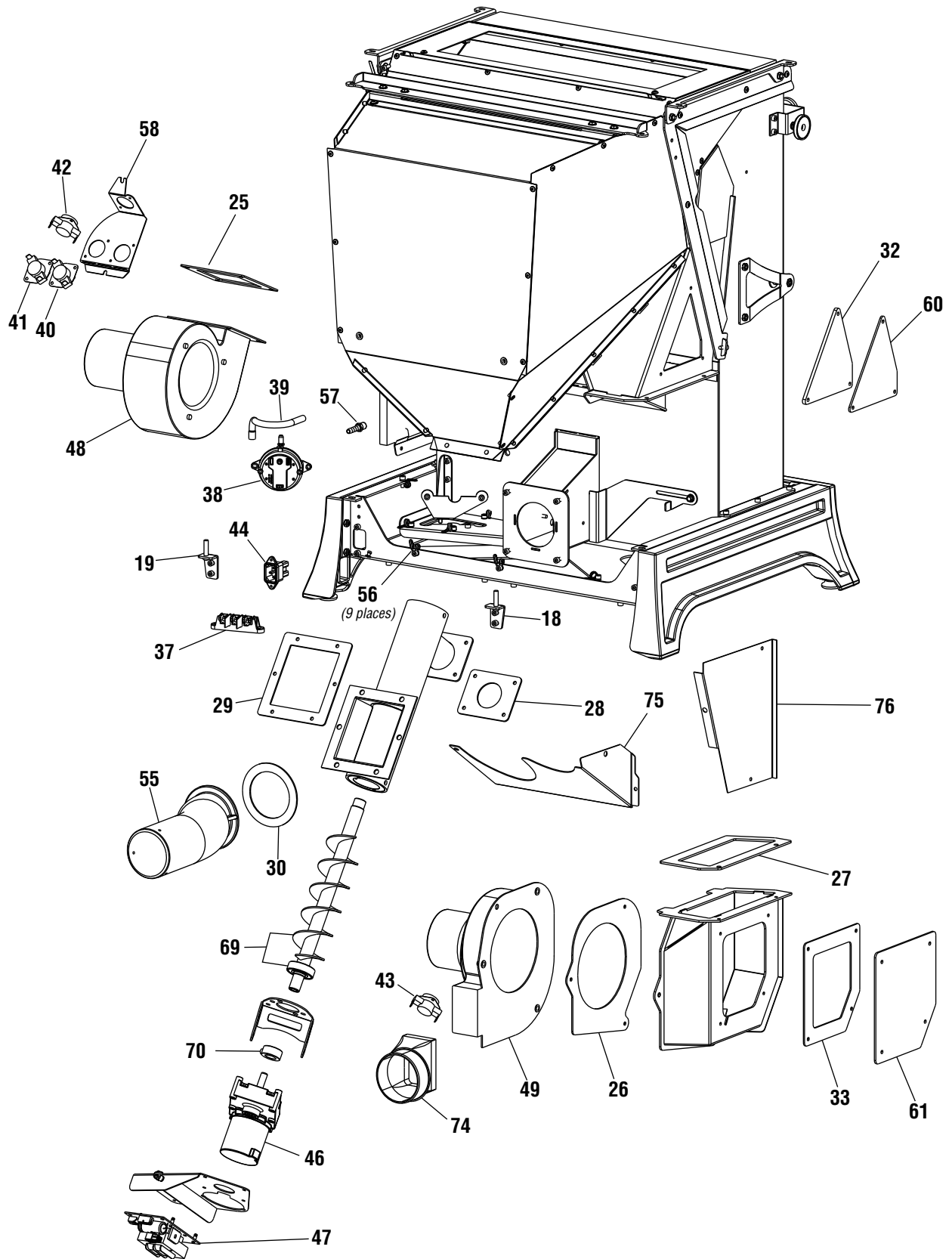

NOTE: DIAGRAMS & ILLUSTRATIONS ARE NOT TO SCALE

OPTIONAL ACCESSORIES

Item #	Cat. No.	Model	Description
Optional Accessories			
1	H3484	BELLA-BPK-T	Brick Panel Kit, Traditional (ref. Form # 506033-13)
2	H3485	BELLA-PK-TB	Stone Panel Kit, Tan Brown (ref. Form # 506033-11)
3	H3488	BELLA-PK-GV	Stone Panel Kit, Gallo Veneziano (ref. Form # 506033-11)
4	H3491	BELLA-PK-SS	Stone Panel Kit, Beatrice Soapstone (ref. Form # 506033-11)
5	H3483	BELLA-LOG	Decorative Log Kit (ref. Form # 506033-12)
6a	H8860	RC-S-1	Remote, Two Button, Timer, On/Off Or Timer Mode
6b	H8861	RCL-S-STAT	Remote, LCD Stat, Thermostat, On/Off
6c	H8865	RC-S-TOUCH	Remote, Touch Screen, Thermostat, On/Off
6d	H8840	KIT-RC-G-FIRE	Remote, Simple On/Off
7a	H8863	WS-S-TMR	Wall Switch, Countdown Timer
7b	H8864	WS-S-TSTAT	Wall Switch, Thermostat
8	H8159	TSPK - B	Touch-up Paint Kit, Metallic Black, 12 oz Spray Can
9	12050004	----	Cleaning Brush (ref. Form # 14720036)
10	H7638	BELLA-LLK	Leveling Leg Kit (4 per pkg.) (ref. Form # 506033-21)
11	H6907	P40DIAG	Diagnostic Tool (ref. Form # 775293M)

NOTE: The form numbers referenced are the part numbers of the instruction sheets included in kits.



NOTE: DIAGRAMS & ILLUSTRATIONS ARE NOT TO SCALE

Innovative Hearth Products IronStrike™ Pellet Stove and Insert Limited Lifetime Warranty

THE WARRANTY

Innovative Hearth Products ("IHP") Limited Lifetime Warranty warrants your IronStrike™ brand pellet fueled stove or insert ("Product") to be free from defects in materials and workmanship at the time of manufacture. The Product body, heat exchange tubes and ceramic glass carry the Limited Lifetime Warranty. Ceramic glass carries the Limited Lifetime Warranty against thermal breakage only. After installation, if covered components manufactured by IHP are found to be defective in materials or workmanship during the Limited Lifetime Warranty period and while the Product remains at the site of the original installation, IHP will, at its option, repair or replace the covered components. If repair or replacement is not commercially practical, IHP will, at its option, refund the purchase price or the wholesale price of the IHP Product, whichever is applicable.

IHP will also pay IHP prevailing labor rates, as determined in its sole discretion, incurred in repairing or replacing such components for up to five years. THERE ARE EXCLUSIONS AND LIMITATIONS to this Limited Lifetime Warranty as described herein.

COVERAGE COMMENCEMENT DATE

Warranty coverage begins on the date of installation. In the case of new home construction, warranty coverage begins on the date of first occupancy of the dwelling or six months after the sale of the Product by an independent IHP dealer/distributor, whichever occurs earlier. The warranty shall commence no later than 24 months following the date of product shipment from IHP, regardless of the installation or occupancy date.

EXCLUSIONS AND LIMITATIONS

This Limited Lifetime Warranty applies only if the Product is installed in the United States or Canada and only if operated and maintained in accordance with the printed instructions accompanying the Product and in compliance with all applicable installation and building codes and good trade practices.

This warranty is non-transferable and extends to the original owner only. The Product must be purchased through a listed supplier of IHP and proof of purchase must be provided. The Product body and heat exchange tubes carry the Limited Lifetime Warranty from the date of installation. Vent components, trim components and paint are excluded from this Limited Lifetime Warranty. The following do not carry the Limited Lifetime Warranty but are warranted as follows:

- Accessories** – Repair or replacement for 90 days from the date of installation
- Cast iron burn pot** - Replacement for five years from the date of installation
- Electrical components** – Repair or replacement for two years from the date of installation
- Firebrick/refractory** – Replacement for 90 days from the date of installation
- Gaskets** – Repair or replacement for one year from the date of installation
- Gold & nickel plating** - Replacement for two years from date of installation. Excludes tarnishing
- Steel burn grate** - Replacement for two years from the date of installation
- Logs** – Replacement for 90 days from the date of installation
- Labor** – Prevailing IHP labor rates apply for the warranty period of the component

Parts not otherwise listed carry a 90 day warranty from the date of installation.

Whenever practicable, IHP will provide replacement parts, if available, for a period of 10 years from the last date of manufacture of the Product.

IHP will not be responsible for: (a) damages caused by normal wear and tear, accident, riot, fire, flood or acts of God; (b) damages caused by abuse, negligence, misuse, or unauthorized alteration or repair of the Product affecting its stability or performance (The Product must be subjected to normal use. The use of fuels other than those outlined in the operation manual provided with the Product will void all warranties and liabilities.); (c) damages caused by failing to provide proper maintenance and service in accordance with the instructions provided with the Product; (d) damages, repairs or inefficiency resulting from faulty installation or application of the Product.

This Limited Lifetime Warranty covers only parts and labor as provided herein. In no case shall IHP be responsible for materials, components or construction which are not manufactured or supplied by IHP or for the labor necessary to install, repair or remove such materials, components or construction. Additional utility bills incurred due to any malfunction or defect in equipment are not covered by this warranty. All replacement or repair components will be shipped F.O.B. from the nearest stocking IHP factory.

LIMITATION ON LIABILITY

It is expressly agreed and understood that IHP's sole obligation and the purchaser's exclusive remedy under this warranty, under any other warranty, expressed or implied, or in contract, tort or otherwise, shall be limited to replacement, repair, or refund, as specified herein.

In no event shall IHP be liable for any incidental or consequential damages caused by defects in the Product, whether such damage occurs or is discovered before or after repair or replacement, and whether such damage is caused by IHP's negligence. IHP has not made and does not make any representation or warranty of fitness for a particular use or purpose, and there is no implied condition of fitness for a particular use or purpose.

IHP makes no expressed warranties except as stated in this Limited Lifetime Warranty. The duration of any implied warranty is limited to the duration of this expressed warranty.

No one is authorized to change this Limited Lifetime Warranty or to create for IHP any other obligation or liability in connection with the Product. Some states and provinces do not allow the exclusion or limitation of incidental or consequential damages, so the above limitations or exclusions may not apply to you. The provisions of this Limited Lifetime Warranty are in addition to and not a modification of or subtraction from any statutory warranties and other rights and remedies provided by law.

INVESTIGATION OF CLAIMS AGAINST WARRANTY

IHP reserves the right to investigate any and all claims against this Limited Lifetime Warranty and to decide, in its sole discretion, upon the method of settlement.

To receive the benefits and advantages described in this Limited Lifetime Warranty, the appliance must be installed and repaired by a licensed contractor approved by IHP.

Contact IHP at the address provided herein to obtain a listing of approved dealers/distributors. **IHP shall in no event be responsible for any warranty work done by a contractor that is not approved without first obtaining IHP's prior written consent.**

HOW TO REGISTER A CLAIM AGAINST WARRANTY

In order for any claim under this warranty to be valid, you must contact the IHP dealer/distributor from which you purchased the product. If you cannot locate the dealer/distributor, then you must notify IHP in writing. IHP must be notified of the claimed defect in writing within 90 days of the date of failure. Notices should be directed to the IHP Warranty Department at 1508 Elm Hill Pike, Suite 108; Nashville, TN 37210 or visit our website at WWW.IRONSTRIKE.US.COM.

WARRANTY

Your pellet stove is covered by a limited warranty (**Page 45**). Please read the warranty to be familiar with its coverage.

Retain this manual. File it with your other documents for future reference.

PRODUCT REFERENCE INFORMATION

We recommend that you record the following important information about your fireplace. Please contact your IHP dealer for any questions or concerns.

REPLACEMENT PARTS

See **Pages 37 through 41** for a complete replacement parts list. Use only parts supplied from the manufacturer.

Normally, all parts should be ordered through your IHP distributor or dealer. Parts will be shipped at prevailing prices at time of order.

When ordering repair parts, always give the following information:

1. The model number of the appliance.
2. The serial number of the appliance.
3. The part number.
4. The description of the part.
5. The quantity required.
6. The installation date of the appliance.



If you encounter any problems or have any questions concerning the installation or application of this system, please contact your dealer.

IHP
1508 Elm Hill Pike, suite 108
Nashville, TN 37210
visit us at www.IronStrike.us.com

Model Number _____
Serial Number _____
Date Installed _____
Dealer's Name _____
Dealer's Phone Number _____

 **NATIONAL FIREPLACE INSTITUTE**
 **NFI**
CERTIFIED
www.nficertified.org

We recommend that our pellet hearth products be installed and serviced by professionals who are certified in the U.S. by the National Fireplace Institute® (NFI) as NFI Pellet Specialists or who are certified in Canada by  **Wood Energy Technical Training (WETT)**.
www.wettinc.ca

 **NATIONAL FIREPLACE INSTITUTE**
 **NFI**
CERTIFIED
www.nficertified.org

Nous recommandons que nos p eles   boulettes soient install es et que l'entretien soit effectu  par des professionnels certifi s, aux Etats-Unis par le National Fireplace Institute® (NFI), et au Canada par le **Wood Energy Technical Training (WETT)**.
 www.wettinc.ca

IHP reserves the right to make changes at any time, without notice, in design, materials, specifications, and prices, and also to discontinue colors, styles, and products. Consult your local distributor for fireplace code information.

