

PELLET STOVE OPERATING & INSTALLATION INSTRUCTIONS

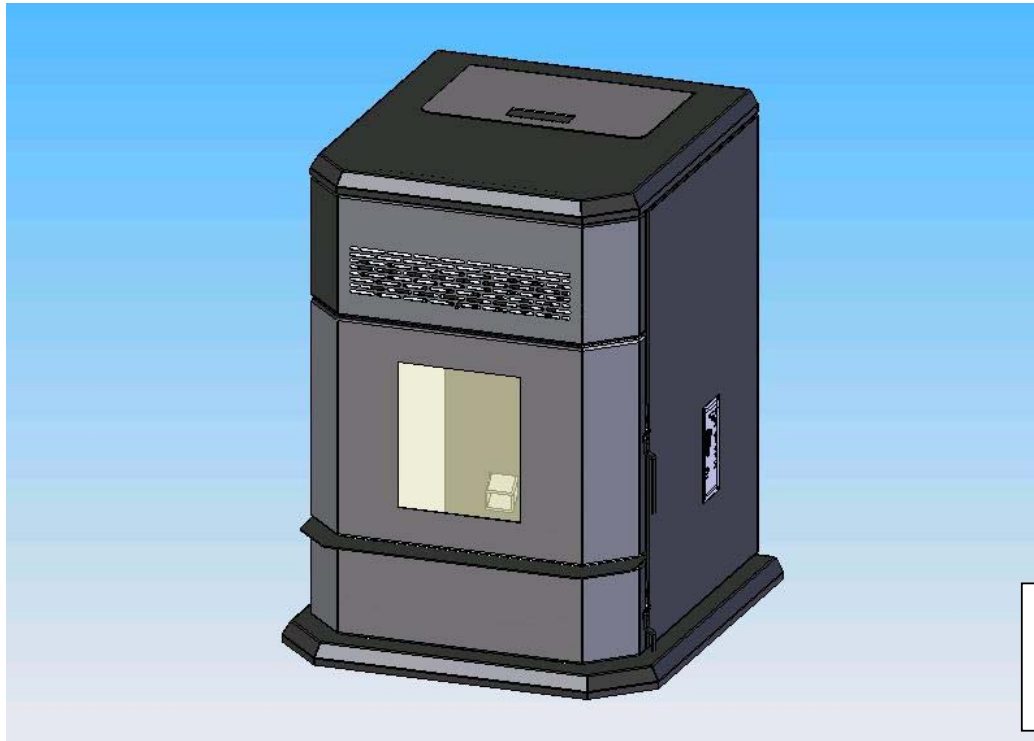

WESTPOINT PELLET STOVE

Please read this entire manual before installation and use of this pellet fuel burning room heater. Failure to follow these instructions could result in property damage, bodily injury or even death.

Contact your local building officials about restrictions and installation inspection requirements in your area.

Save these instructions.



1871 Route 9H
Hudson, NY 12534
U.S.A.
Phone: 518-828-6363
Fx: 518-828-5639

TABLE OF CONTENTS

Introduction.....	3
Safety Information	4 - 5
Specifications.....	6
Dimensions	6
Operating Instructions.....	7 - 10
Thermostat Installation	11
Clearances to Combustibles.....	13
Installing Your Room Heater.....	12 - 21
Mobile Home Installations.....	23
Vent Termination Locations	24
Maintenance	25 - 28
Troubleshooting	29 - 30
Wiring Diagram	31
Replacement Parts List	32
Warranty	33 - 34

INTRODUCTION

Thank you for purchasing the Westpoint pellet stove. The Westpoint has been tested and listed for installation in residential and mobile homes.

This heater has been certified to ASTM E1509-04 *Standard Specification for Room Heaters, Pellet Fuel-Burning Type*.

The performance of your pellet stove can be affected by the type of pellet fuel burnt in the appliance. It is important to use only pellet fuel that is dry and free from dirt or other impurities.

The Pellet Fuel Industry has established standards for wood pellet manufacturers. It is recommended that the fuel used in this appliance meet or exceed the following specifications:

Fines (fine particles).....	1% maximum through a 1/8" screen
Bulk Density.....	minimum 40 lbs per cubic foot
Size.....	maximum 3/8" diameter by 1-1/2" long
Ash Content.....	1% maximum (Premium grade)
3% maximum (Standard grade)
Moisture Content.....	8% maximum
Heat Content.....	minimum 8,200 btu/hr

It is important to note that the ash content of the fuel (and frequency of operation) determine the frequency of cleaning required for your unit. A high ash fuel may result in your unit having to be cleaned daily while a low ash content fuel may permit a longer time between cleaning.

Occasionally impurities in the fuel will cause a hard mass build up in the burn pot. This build up may block the air flow through the burn pot affecting the performance of your unit. Check the burn pot daily for any blockage. If necessary remove the burn pot liner (once unit has cooled) and clean the liner and the burn pot.

Since Hudson River Stove Works has no control over the quality of pellet fuel used in this unit they assume no responsibility for the end users choice in wood pellets.

Caution: Be sure to store the pellet fuel a minimum of 3' (0.9 m) away from the pellet stove.

Please note that the rating label may be found on the inside of the right hand door.

SAFETY INFORMATION

Be sure to read the entire owner's manual prior to installing and operating this pellet fuel burning heater.

Failure to follow these instructions could result in property damage, bodily injury or even death.

This stove's exhaust system works with negative combustion chamber pressure and a slight positive chimney pressure, it is extremely important to ensure that the exhaust system be sealed and airtight. The ash pan and viewing door must be securely fastened in order for the unit to be airtight. This appliance will not operate using natural draft or without a power source for the blowers.

The use of grates or other methods of supporting the fuel is not permitted.

This unit is designed to burn pellet wood fuel only. Do not use any other type of fuel, this will void any warranties stated in this manual. **THE USE OF CORDWOOD IS PROHIBITED BY LAW.**

This appliance is designed for residential installation according to current national and local building codes. It is also approved as a mobile home heater which is designed for connection to an outside combustion air source.

It is recommended that the exhaust vent be cleaned bi-annually or after every two tons of pellets.

Soot or creosote may accumulate when the stove is operated under incorrect conditions such as an extremely rich burn (black tipped lazy orange flames). Do not operate the stove if the flame becomes dark or sooty or if the burn pot overfills with pellets. Turn the stove off and call your dealer.

The grounded electrical cord should be connected to a standard 120 volt, 60 hertz electrical outlet. Ensure that the electrical cord is not trapped under the appliance and that it is clear of any hot surfaces or sharp edges.

Be sure that the structural integrity of the home is maintained when passing venting through walls, ceilings or roofs.

The ash pan and viewing door must be locked securely for proper and safe operation of the pellet stove.

DO NOT PLACE UNBURNED OR NEW PELLETS FUEL IN ASH PAN. A fire in the ash pan may occur.

Do not abuse the glass by striking or slamming the door. Do not attempt to operate the unit with broken glass. Replacement glass must be purchased from a Hudson River Stove Works dealer. Do not attempt to clean the glass while unit is hot. To clean the glass, use a soft cotton cloth and woodstove cleaner.

SAFETY INFORMATION (continued)

Do not operate your stove if you smell smoke coming from it. Turn it off, monitor it and call your dealer.

Repair and servicing of your stove may only be done by a qualified technician.

Disconnect the power cord before performing any maintenance or repair. NOTE:

Turning the stove to "off" does not disconnect all power from the unit.

The stove will not operate during a power outage, if this happens check for smoke spillage and open a house window if necessary.

Keep foreign objects out of the hopper.

Contact your local building officials to obtain a permit and information on any installation restrictions or inspection requirements in your area. Notify your insurance company of your new stove.

Allow the stove to cool before performing any maintenance.

Ashes must be disposed of in a metal container with a tight lid and placed on a non-combustible surface well away from your home.

Check the venting system, at least twice a year, for creosote build up.

This pellet stove appliance is designed to use outdoor air for combustion. Always install a manufactured fresh air intake kit from outside of the residence. See the Installation section for the correct part numbers when ordering these components.

This pellet stove may only be installed using Type L, listed venting components that meet the UL641 & ULCS609 requirements.

When a room heater is intended to exhaust to a chimney, the connector pipe from the room heater to the wall thimble or ceiling adapter shall meet the requirements specified in NFPA 211 or the applicable building and mechanical codes. If factory-built, the chimney specified shall be listed to the requirements of UL 103 or ULC S629M or, if masonry, shall meet the construction requirements of the applicable building and mechanical codes.

CAUTION:

DO NOT CONNECT TO ANY AIR DISTRIBUTION DUCT OR SYSTEM.

NEVER USE GASOLINE, GASOLINE TYPE LANTERN FUEL, KEROSENE, CHARCOAL LIGHTER FLUID, OR SIMILAR LIQUIDS TO START OR FRESHEN UP A FIRE IN THE HEATER. KEEP ALL SUCH LIQUIDS WELL AWAY FROM THE HEATER WHILE IT IS IN USE.

HOT WHILE IN OPERATION. KEEP CHILDREN, CLOTHING AND FURNITURE AWAY FROM THE HEATER. CONTACT MAY CAUSE SKIN BURNS. YOUNG CHILDREN SHOULD BE SUPERVISED WHEN THEY ARE IN THE SAME ROOM AS THE STOVE.

SPECIFICATIONS

Heating Specifications:

Burn Rate.....6.5lbs/hr on #5 setting. *55,000 - 60,000 Btu's/hr

Hopper Capacity.....130 lbs.

*Depends on quality and heating value of pellet fuel.

DIMENSIONS

Figure 1

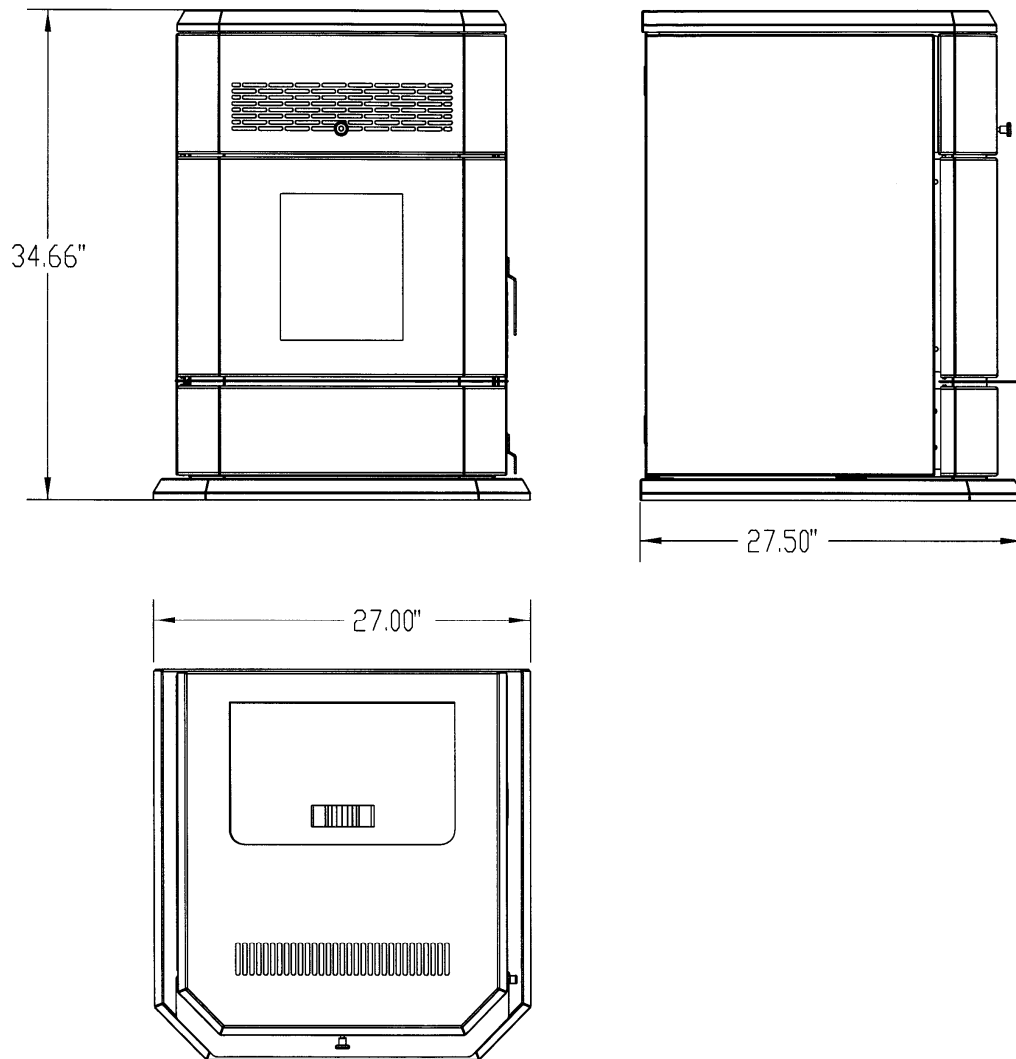

OPERATING INSTRUCTIONS

Filling the Hopper

To open the hopper lid on the freestanding unit simply lift up and fill with pellets.

CAUTION: Do not overfill the hopper. (130lbs from empty)

Pre-start check up

Remove the burn pot (only if unit is cool) and clean out any ash debris. Be sure to install the burn pot in the correct position (see page 25).

The blowers and automatic fuel supply are controlled from a panel located on the right hand side of the stove.

Note: During the first time your unit is fired it may omit an odor as high temperature paint cures. Maintaining a smaller fire (for the first few hours) will help to minimize this. Avoid placing any items on the stove top during this period as the unit's paint could be permanently damaged.

Lighting Instructions

When first operating the pellet stove, switch it to manual mode, so you can have full control of the pellet stoves control board functions and familiarize yourself with how the pellet stove works. It is in this mode that the heat level for the AUTO and T-STAT mode is set.

To Start up a Cold Stove

Press and release the On/Off button. The green light above the On/Off button will flash to indicate that the start up cycle has started. The light above the Auger button will turn on, intermittently, indicating the activation of the auger which is feeding the pellets into the burn pot. At this time the electric igniter is activated. The igniter takes a few minutes to heat up enough to ignite the pellets in the burn pot. This may take as little as 3 minutes or as much as 8 minutes. **If no flames appear prior to 15 minutes the stove will shut down and will need to be turned back on again.**

Once the flame has been established, the start up cycle will end, this takes between 10 - 15 minutes. At this point, if the stove is in the manual mode, it will default to the lowest heat level setting. If the stove is in either the AUTO or T-STAT mode the heat output will vary in accordance with the commands from the thermostat.

OPERATING INSTRUCTIONS

To Start up a Hot Stove

If the stove is warm at re-start, the On/Off button must be pressed down and held for 2 seconds or more until the Heat Level light is lit.

When first starting a new pellet stove, or when you completely empty the hopper of pellets, you can press and hold the AUGER button to get the pellets into the burn pot quicker. See AUGER button description on page 9.

The convection air flow will change in accordance with the heat setting. Convection air flow is at maximum when the heat setting is at maximum. Air flow will be at a minimum when the heat setting is at a minimum. If the user wishes to turn the convection fan on maximum, at any heat setting, they may do so by pressing the FAN button.

If the flame goes out, or the heat output is too high on minimum heat level setting, use the AUGER TRIM button to make adjustments. See the AUGER TRIM button description on page 10.

To Shutdown Stove

Turn off the unit by pressing the On/Off button. The stove will enter the shutdown cycle where the pellets will stop feeding to allow the fuel in the burn pot to be used up. The exhaust blower and convection fan will continue to operate until the flames are out and the unit has cooled down. Once this has been accomplished the stove will shut down completely.

In the AUTO mode turning the thermostat all the way down can also be used to turn off the stove.

DO NOT TURN OFF THE UNIT BY DISCONNECTING THE ELECTRICAL POWER TO THE UNIT. THIS WILL CAUSE THE UNIT TO MISS THE PROPER SHUTDOWN CYCLE, CAUSING THE RELEASE OF SMOKE INTO THE HOUSE AND OVERHEATING OF THE STOVE.

OPERATING INSTRUCTIONS

Control Board Functions

T-STAT/Manual Switch: This switch selects the pellet stove operating mode. Slide the switch to Manual (the far right position) to be able to manually select the heat settings and controls.

If you have a remote thermostat attached and wish to have the pellet stove controlled by the thermostat, slide the switch to T-STAT (the middle position) to operate the pellet stove in variable heat mode. The thermostat will control the heat output of the pellet stove alternating between the lowest heat level and the highest heat level pre-selected by the user.

After switching between modes the stove should be turned Off and back On to reset the control to operate in that mode.

On/Off Button: This button is used to turn the unit on and off. If the stove is cold prior to start-up press and release the On/Off button. The green light above the On/Off switch will flash to indicate start up cycle has started. Fuel pellets will start to feed into the burn pot. The electric ignition system will be automatically activated, flames in the burn pot will normally appear between 3 - 7 minutes. Once the flame has been established, the start up cycle will end, this takes between 10 -15 minutes. At this point the user will be able to make heat level adjustments.

If the stove is warm at restart the On/Off button must be pressed down and held for 2 seconds, or more, until the minimum heat level setting light is lit.

Heat Level: When pressed this increases the heat level setting one level. Pressing the button will cycle the heat setting from minimum to maximum and back again. The convection fan speed will also increase with the heat level setting. When the light is flashing during the start up cycle the heat level button will not respond to the adjustments. When the light is solid, indicating the start up cycle is finished, it will then respond (only in manual mode).

Fan: Use this button to override the automatic fan speed control to turn the convection fan on high. The smart control on this pellet stove will vary the fan speed in accordance with the heat level setting. It is recommended to let the controller automatically adjust the speed of the fan for optimum efficiency and minimal fan noise.

Auger: Pressing and holding this button will turn on the auger to speed feeding of pellets into the burn pot, when first using the pellet stove or when you completely empty the hopper of pellets and restarting after reloading the hopper. You can load the auger faster by pressing and holding this button (until you see pellets dropping into the burn pot). This button will turn off after 1 minute and must be released and pressed again if you want to continue to manually operate the auger.

OPERATING INSTRUCTIONS

Control Board Functions (continued)

Auger Trim: This is used to change the feed rate on the minimum heat level for various quality of pellet fuel. This will help to keep the flames from extinguishing on the minimum heat level setting. It is also used to lower heat output on the minimum heat level setting.

Push and release the Auger Trim button until the heat level 1 and 5 lights appear. This will slightly increase the feed rate on the minimum heat level setting to keep the burn pot flames from going out.

Push and release the button until the heat level 1 and 4 lights appear, this will reduce the pellet feed rate on the minimum heat level setting. Use this setting to reduce the heat level output on low.

Push and release the button until just the heat level 1 setting light is on, this is the factory setting and works for most types of fuel.

Figure 2

Control Panel

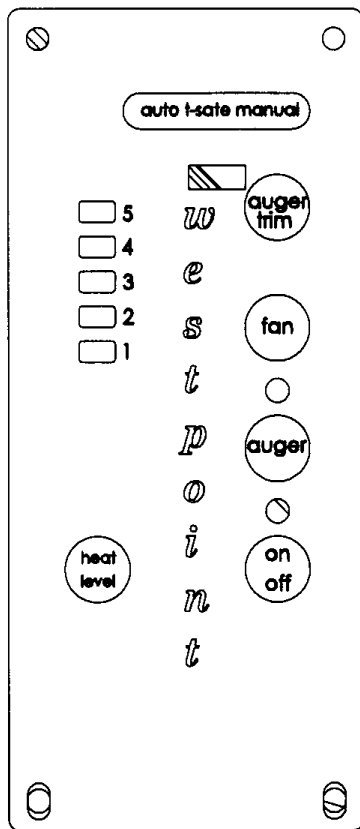

Open Door

If the door is opened, while the unit is operating, it must be closed within 30 seconds or the unit will go into vacuum error mode. If this happens, close the door, turn the control panel switch to "OFF" then back to the setting it was previously at.

Refueling

For maximum performance we recommend that you do not let the hopper drop below 1/4 full. **KEEP LID CLOSED AT ALL TIMES EXCEPT WHEN REFILLING. DO NOT OVERFILL HOPPER.**

Safety Features

1. Your unit is equipped with a "high temperature limit" thermo snap disc. This snap disc serves to shutdown the auger in the case of an over temperature situation (such as convection fan failure). This disc has a manual reset button that will have to be reactivated once the unit has cooled down.
2. If the combustion fan malfunctions a vacuum switch will automatically shut down the auger (see also Open Door section above).

If either of these situations occur contact your dealer as a service call may be required.

THERMOSTAT INSTALLATION

An optional thermostat is available for use with this unit. A thermostat can help you maintain a constant room temperature. A milli-volt thermostat is required.

NOTE: Your thermostat should be installed by an authorized dealer or service person.

To Install Thermostat:

- Disconnect unit from power supply.
- Open right side panel to gain access to rear of control panel.
- Take the thermostat wires and connect to the green screw terminal on the rear of the control panel (see Figure 3).

When the room cools to below the thermostat setting the stove will automatically restart and run at the last feed rate setting. When the room is warm enough the unit will shut off. The exhaust fan will continue to run until the stove cools.



Figure 3

screw connection for thermostat

INSTALLING YOUR ROOM HEATER

DO NOT INSTALL A FLUE DAMPER IN THE EXHAUST VENTING SYSTEM OF THIS UNIT.

DO NOT CONNECT THIS UNIT TO A CHIMNEY FLUE SERVING ANOTHER APPLIANCE

INSTALL VENT AT CLEARANCES SPECIFIED BY THE VENT MANUFACTURER.

It is recommended that horizontal through wall installations include 4-6 ft. of vertical external vent to help provide the appliance with a natural draft. This draft will aid in the event of extreme weather or power outage.

This pellet stove appliance is designed to use outdoor air for combustion. Always install a manufactured fresh air intake kit from the outside of the residence. See the section on installation for the correct part numbers when ordering these components. Always make sure the air intake has protective mesh to keep rodents out.

This pellet stove appliance may only be installed using Type L or Type PL, listed venting components that meet the UL641 or ULCS609 requirements.

When a room heater is intended to exhaust to a chimney, the connector pipe from the room heater to the wall thimble or ceiling adapter shall meet the requirements specified in NFPA 211 or the applicable building and mechanical codes. If factory-built, the chimney specified shall be listed to the requirements of UL 103 or ULC S629M or, if masonry, shall meet the construction requirements of the applicable building and mechanical codes.

The pellet stove can be vented through an exterior wall or into an existing masonry or metal chimney. The chimney must be lined if over 6" (150mm) in diameter or if it has a cross sectional area of over 28 square inches. Venting can pass through the ceiling and roof if listed pipe is used.

Do not obtain combustion air from the attic, garage or any other unventilated area. You may obtain combustion air from a ventilated crawl space.

- 1/. Your first step is to decide where to install your pellet stove. In order to get the best use of circulated heat we recommend to install it in a large open room centrally located in the house.
- 2/. Next it is very important to check that clearances to combustibles are maintained, these can be found on page 13 of this manual and on the rating label of the pellet stove. Locate your appliance in a location which meets the requirements of this manual and where it does not interfere with the house framing, wiring, or plumbing, etc.. See figure 14 to determine appropriate vent termination locations.

CLEARANCES TO COMBUSTIBLES

INSTALL VENT AT CLEARANCES SPECIFIED BY THE VENT MANUFACTURER.

Figure 4

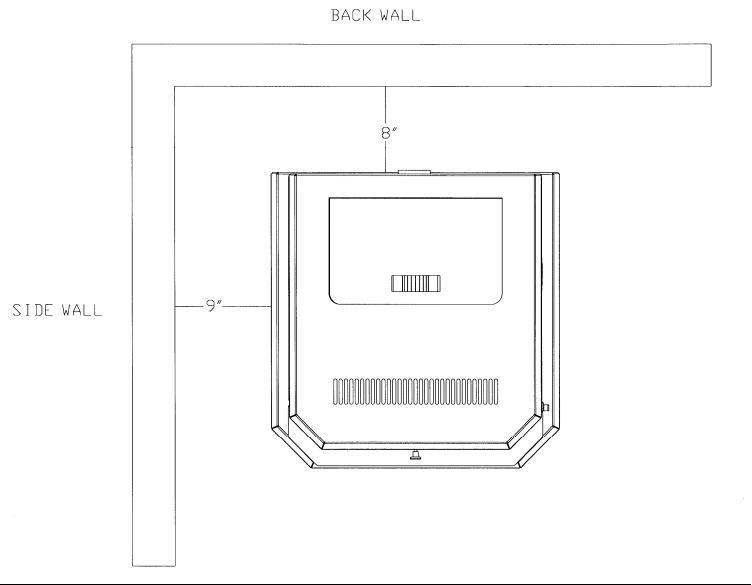
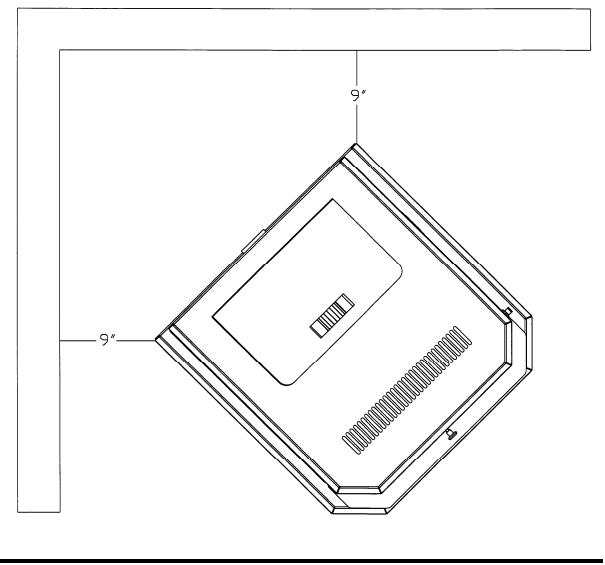

Figure 5



- 3/. Make sure the appliance is within 6' of a power outlet
- 4/. This stove is designed so that no floor pad is required, however we do recommend installing one. **DO NOT** install your stove directly onto carpeting.
- 5/. Place the stove approximately 15" (381 mm) away from the interior wall.
- 6/. See the appropriate sections below for continued instructions for your specific vent requirements.

HORIZONTAL EXHAUST VENT INSTALLATION

- 7/. Locate the center of the exhaust pipe and air intake connector of your unit. These points should then be extended to the interior wall of your house. Once you have located the center point, on the interior wall, cut a hole in the wall as shown in the instructions accompanying the wall thimble.

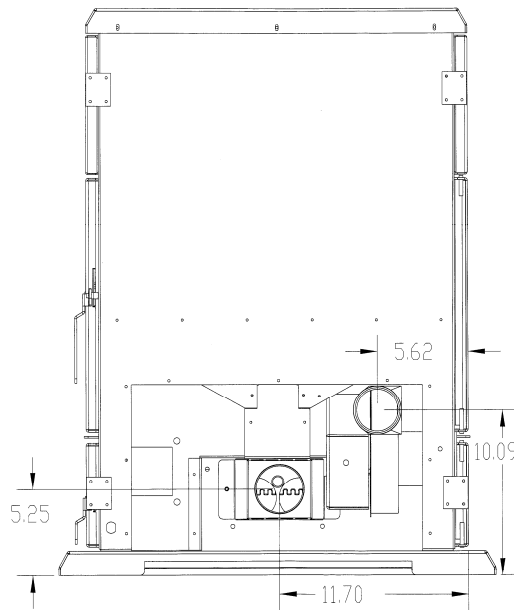

- 8/. The next step is to install the wall thimble, refer to the instructions which come with the wall thimble for this step.
- 9/. Install the appropriate length of exhaust vent pipe into the wall thimble. See step 11 when determining the correct length of exhaust vent to use.
- 10/. Install the combustion air intake pipe. The unit is to use outside air for combustion. Be sure that the outside air vent has a proper cap on it to prevent rodents from entering and also is installed where it won't become blocked with snow, etc..
- 11/. Connect the exhaust vent pipe to the exhaust outlet of your appliance.
- 12/. Secure all vent joint connections with 3 screws. Seal the exhaust vent joint connections with high temperature silicone sealant.
- 13/. Push the unit straight back to the interior wall but be sure to maintain the minimum clearances to combustibles 8" (204 mm) to the back of the unit and a minimum of 9" (229mm) to the sides of the unit. Seal the annular space, of the wall thimble, around the vent pipe with high temperature silicone sealant.

- 14/. The exhaust vent pipe must extend at least 12" (300 mm) out past the exterior wall. Seal the annular space, of the wall thimble, around the vent pipe with high temperature silicone sealant.
- 15/. Install a listed horizontal termination cap or if necessary install a 90° elbow and appropriate length of vertical venting. A listed vertical vent cap is recommended however (if local codes allow) when the vent terminates several feet above ground level and there are no trees, plants, etc. within several feet a 45° elbow can be used as a termination. The elbow must be turned down to prevent rain from entering.

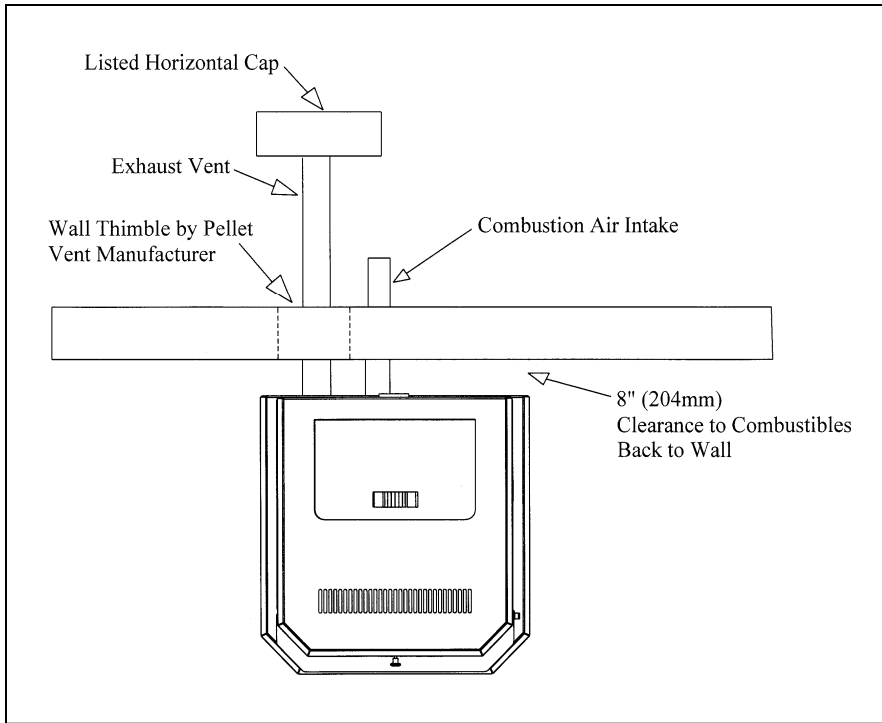

Figure 6

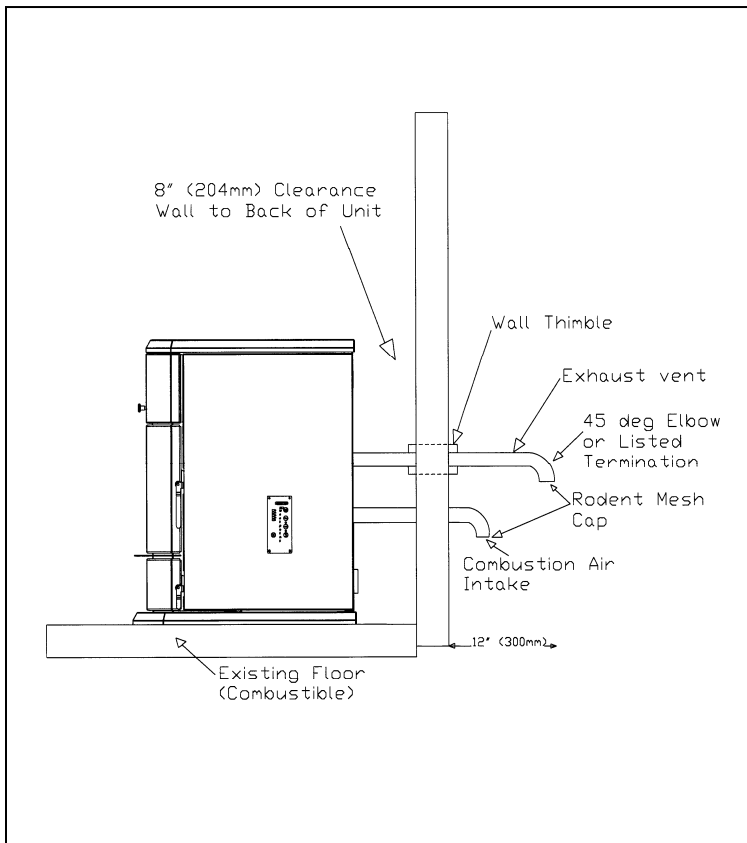

Figure 7

FREESTANDING INTERIOR VERTICAL INSTALLATION

1. Place your pellet stove in the desired position and locate the unit in manner that will leave the exhaust vent with a minimum of 3" (75 mm) clearance to any combustible wall.
2. Locate the center of the combustion air intake pipe at the back of your unit. Line up the center with the same spot on your exterior wall and cut a hole 3" (75 mm) in diameter through the wall.
3. Secure all vent joint connections with 3 screws. Seal the exhaust vent joint connections with high temperature silicone sealant.
4. Install the combustion air intake pipe.
5. Install a tee, with a cleanout, on the exhaust pipe found at the rear of your unit.
6. Install listed vent upward through the ceiling. When you pass through the combustible framing ensure that the appropriate ceiling is used. You must maintain a minimum 3" (75 mm) clearance to combustibles and keep any insulation away from the exhaust vent.
7. Extend the exhaust vent through the roof flashing and ensure that the vertical cap is approximately 36" (900 mm) above the roof.

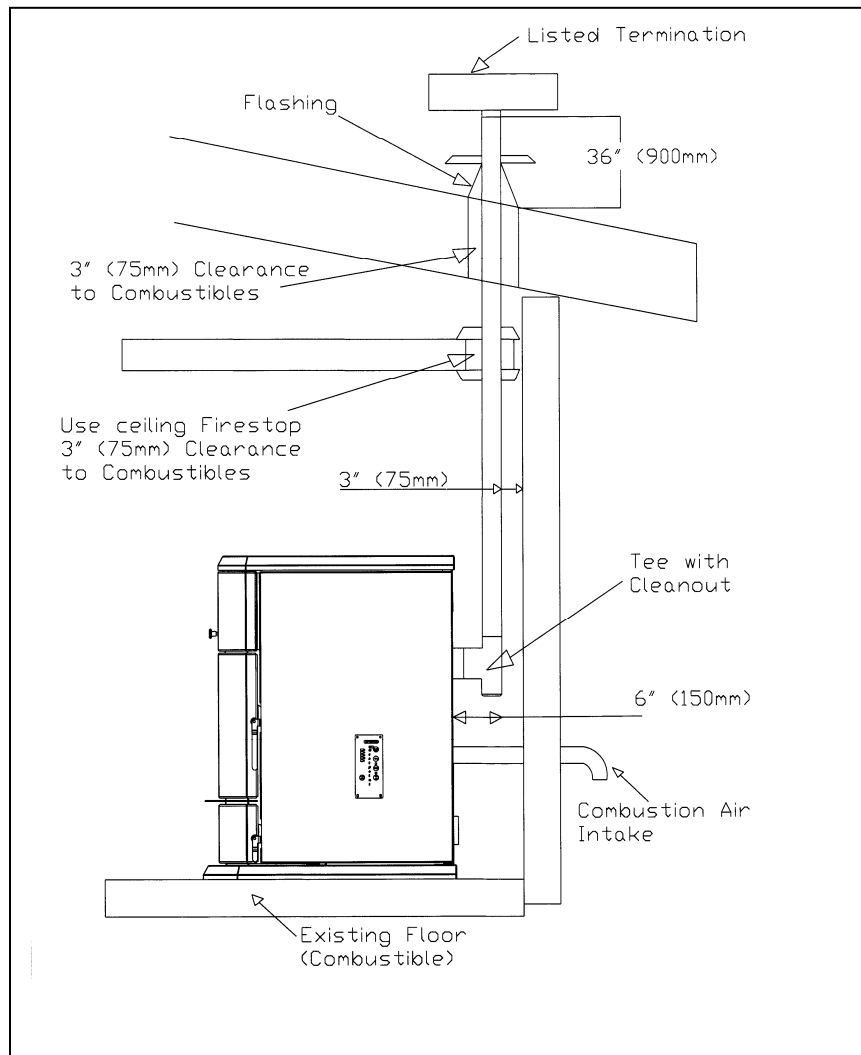
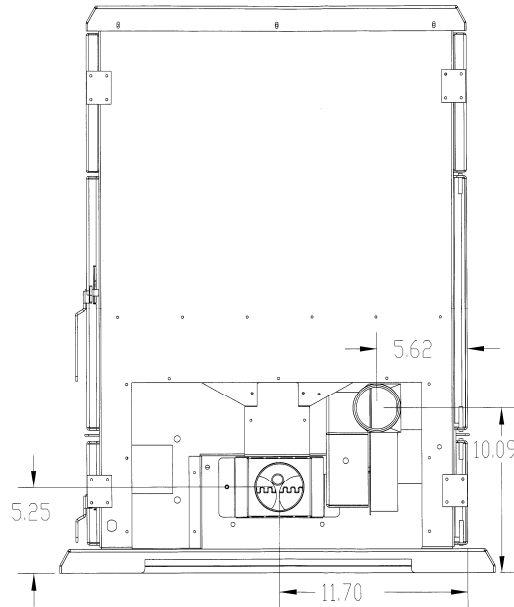

Figure 8

FREESTANDING EXTERIOR VERTICAL INSTALLATION

- 7/. Locate the center of the exhaust pipe, and air intake connector of your unit. These points should then be extended to the interior wall of your house. Once you have located the center point, on the interior wall, cut a hole in the wall as shown in the instructions for the accompanying wall thimble.



- 8/. Install a listed exhaust vent through the wall, be sure to make sure that 3" (75 mm) clearances to combustibles are maintained.
- 9/. Secure all vent joint connections with 3 screws. Seal the exhaust vent joint connections with high temperature silicone sealant.
- 10/. Install a Tee with a cleanout on the end of the exhaust pipe, then install listed venting upward from there. Be sure to install support brackets every 5' (1500 mm) to keep the venting straight and secure.
- 11/. Extend the exhaust vent through the roof flashing and ensure that the vertical cap is approximately 36" (900 mm) above the roof.

Figure 9

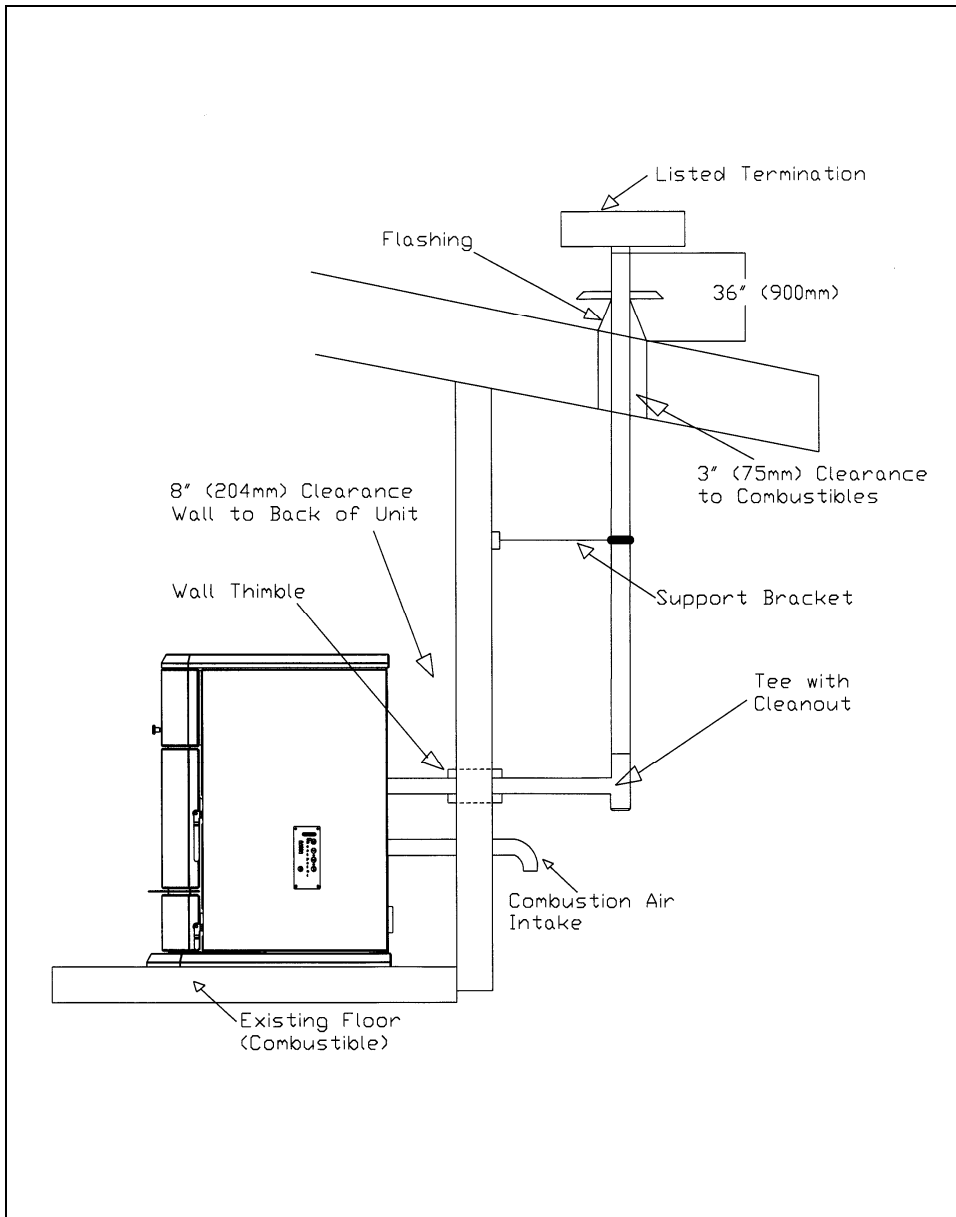

SELKIRK DIRECT-TEMP VENT SYSTEM FOR PELLET APPLIANCES

Images courtesy of Selkirk

ADVANTAGES - DIRECT-TEMP® for Pellet and Corn

- Inherent design of Direct-Temp® eliminates fly ash into room
- 1" clearance to combustibles
- Preheats intake air for more efficient combustion
- Gasketed joints eliminate need for messy sealant
- One installation includes outside air for combustion
- Single stack looks more like a wood burning stove

OPTIONAL TERMINATION CONFIGURATIONS

Vertical Termination –
4DT-VPFTA, 4VP-VC

Horizontal Termination –
4DT-VPFTA, 4VP-EC or
4DT-DCC

Horizontal Termination with 45° Horizontal Termination Elbow –
4DT-VPFTA, 4DT-VPTE,
4VP-EC or 4DT-DCC

PELLET STOVE HORIZONTAL TERMINATIONS (4VP-EC)

- Straight out exhaust using Selkirk Model VP Exit Cap (4VP-EC) or Decorative Cone Cap (4DT-DCC)
- 45-degree Horizontal Termination Elbow with 4VP-EC or 4DT-DCC to divert exhaust directionally



PELLET STOVE ADAPTER (4DT-VPFTA)

- Connects to pellet vent tee for vertical installations
- Connects direct to pellet stove for straight out horizontal installations
- Allows outside combustion air to be directed to pellet stove
- Flue gases exhaust in 304 stainless steel pipe



FLEX PIPE

- For outside combustion air
- Included in 4DT-CAK

PELLET STOVE TERMINATION ADAPTER (4DT-VPFTA)

- Connects to Direct-Temp® direct vent system
- Includes intake for outside combustion air
- Connects to either horizontal Selkirk Model VP Exit Cap (4VP-EC), Decorative Cone Cap (4DT-DCC), 45-degree Horizontal Termination Elbow with 4VP-EC, 4DT-DCC or vertical Selkirk Model VP Vertical Termination (4VP-VC)



THE BEST LIFETIME WARRANTY IN THE INDUSTRY!

DIRECT-TEMP®

Complete direct vent system components to fit most any pellet or corn installation.



PELLET PIPE™

Complete line of components to fit any 3" or 4" pellet or corn stove.



SELKIRK DIRECT-TEMP VENT SYSTEM FOR PELLET APPLIANCES

Images courtesy of Selkirk

UP & OUT HORIZONTAL TERMINATION KIT

Figure 10

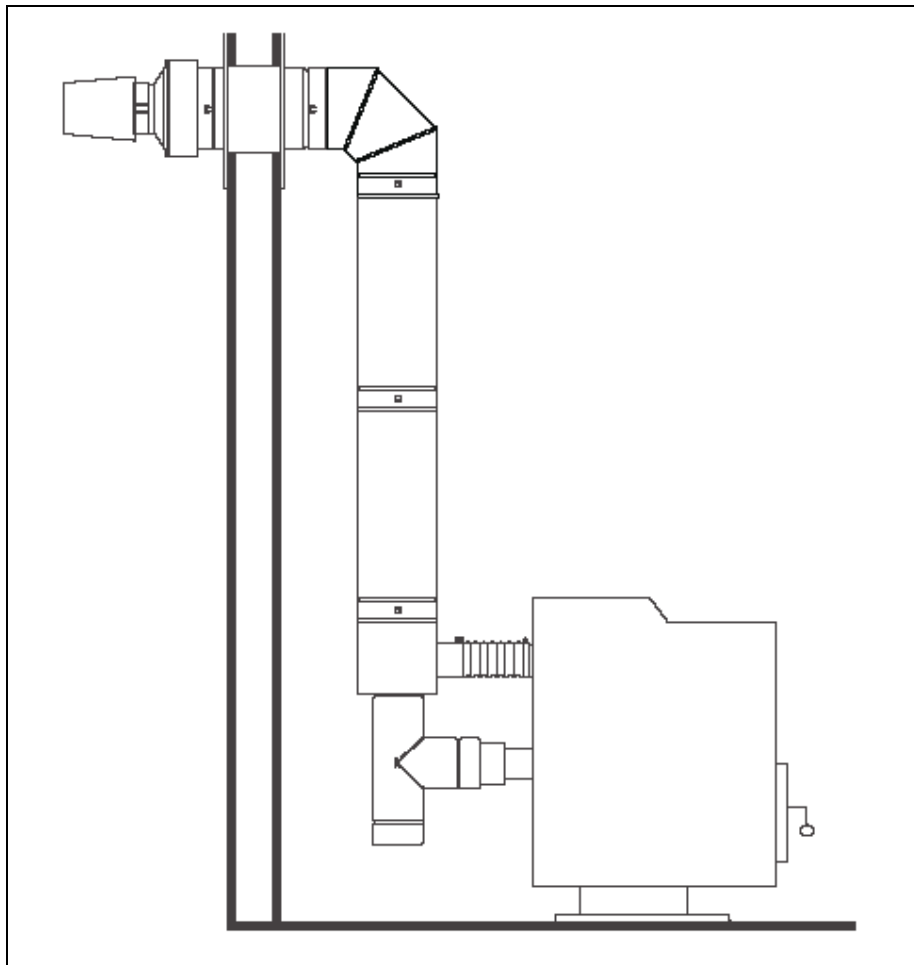

SELKIRK DIRECT-TEMP VENT SYSTEM FOR PELLET APPLIANCES

Images courtesy of Selkirk

STRAIGHT OUT HORIZONTAL TERMINATION KIT

Figure 11

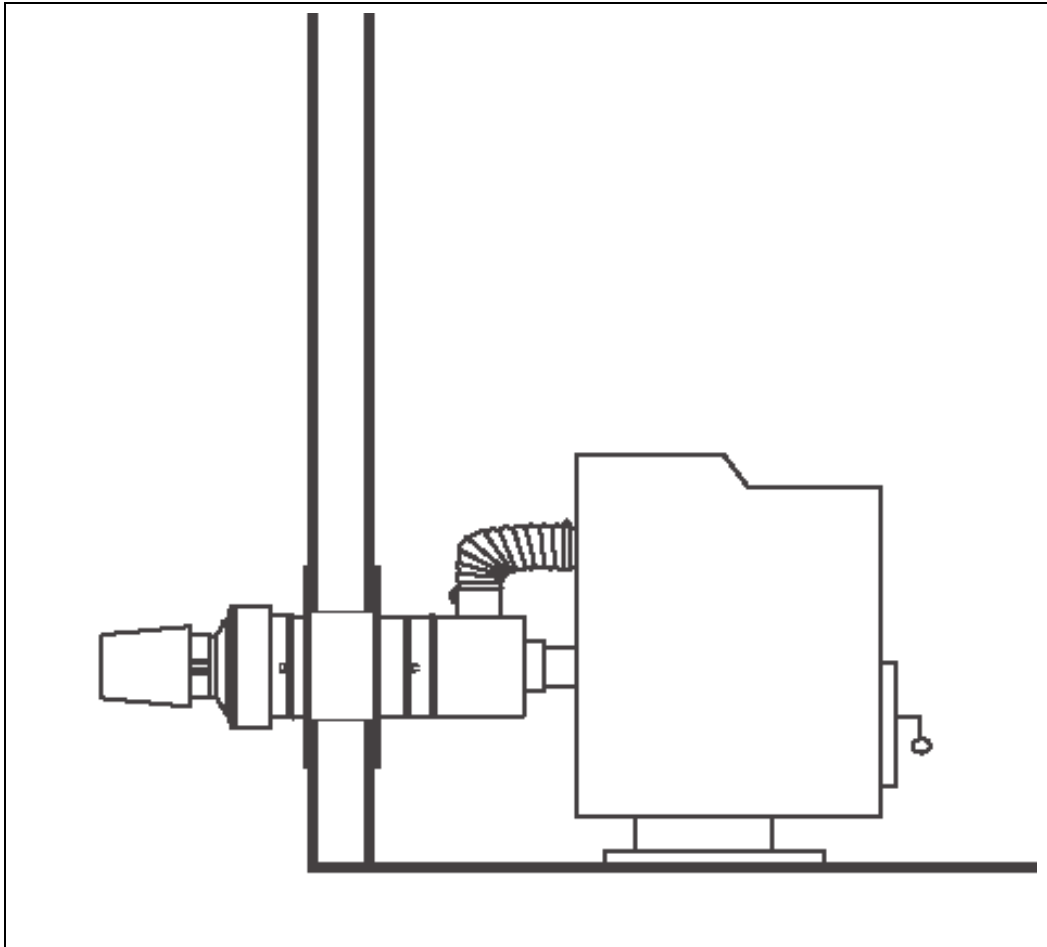

SELKIRK DIRECT-TEMP VENT SYSTEM FOR PELLET APPLIANCES

Images courtesy of Selkirk

THROUGH THE ROOF VERTICAL TERMINATION KIT

Figure 12

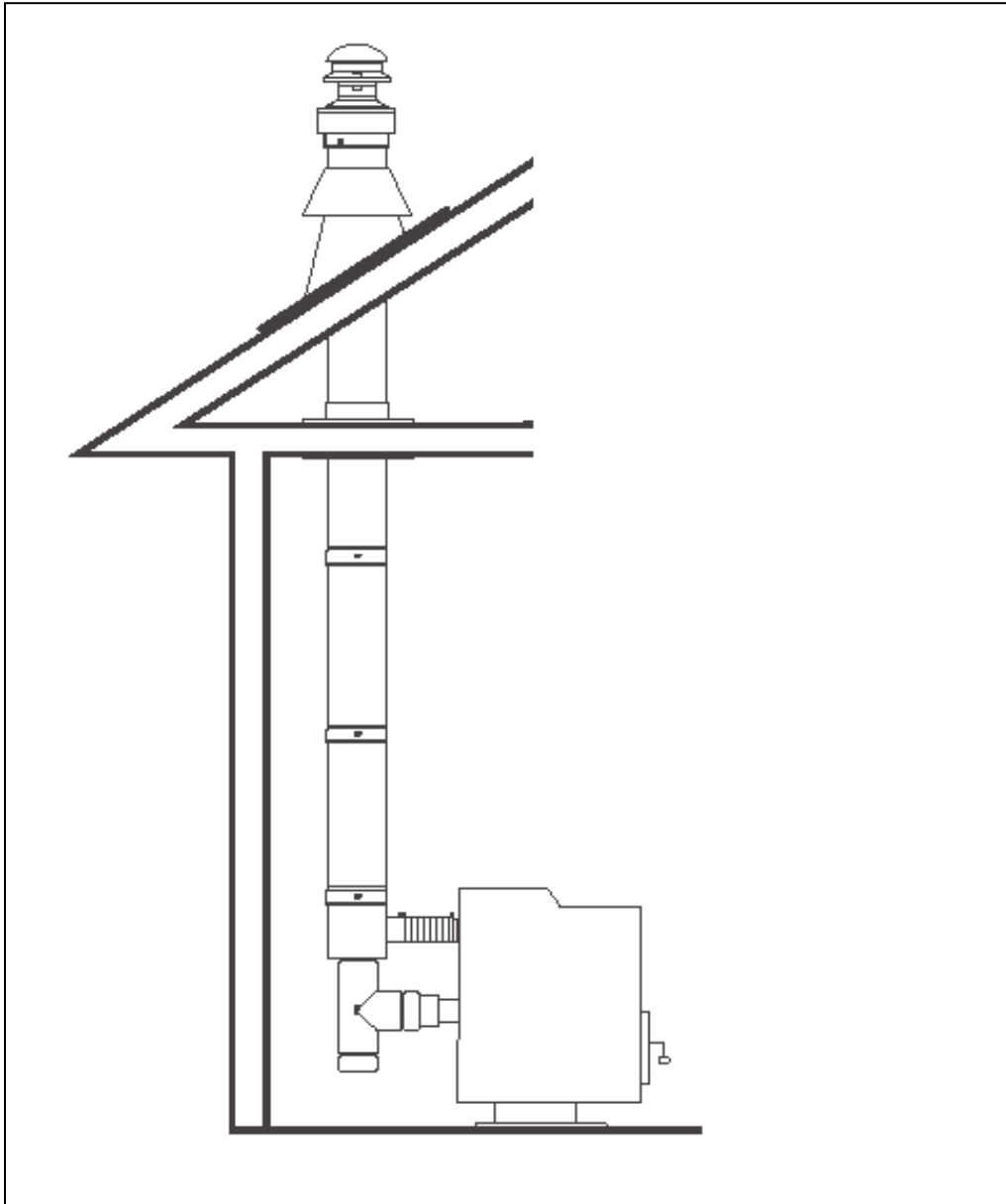

MOBILE HOME INSTALLATION

Mobile home installation should be done in accordance with the Manufactured Home and Safety Standard (HUD), CFR 3280, Part 24.

In order for this unit to be installed in a mobile home the following criteria must be met:

- The unit must be secured to the floor using lag bolts in the holes provided in the pedestal base.
- Ensure that the unit is permanently electrically grounded to the chassis of your home.

IT IS MANDATORY TO TAKE THE COMBUSTION AIR FROM THE OUTSIDE WHEN INSTALLING THIS UNIT IN AIR TIGHT OR MANUFACTURED/MOBILE HOMES.

CAUTION:

THE STRUCTURAL INTEGRITY OF THE MANUFACTURED HOME FLOOR, WALL, AND CEILING/ROOF MUST BE MAINTAINED.

WARNING:

DO NOT INSTALL IN SLEEPING ROOM.

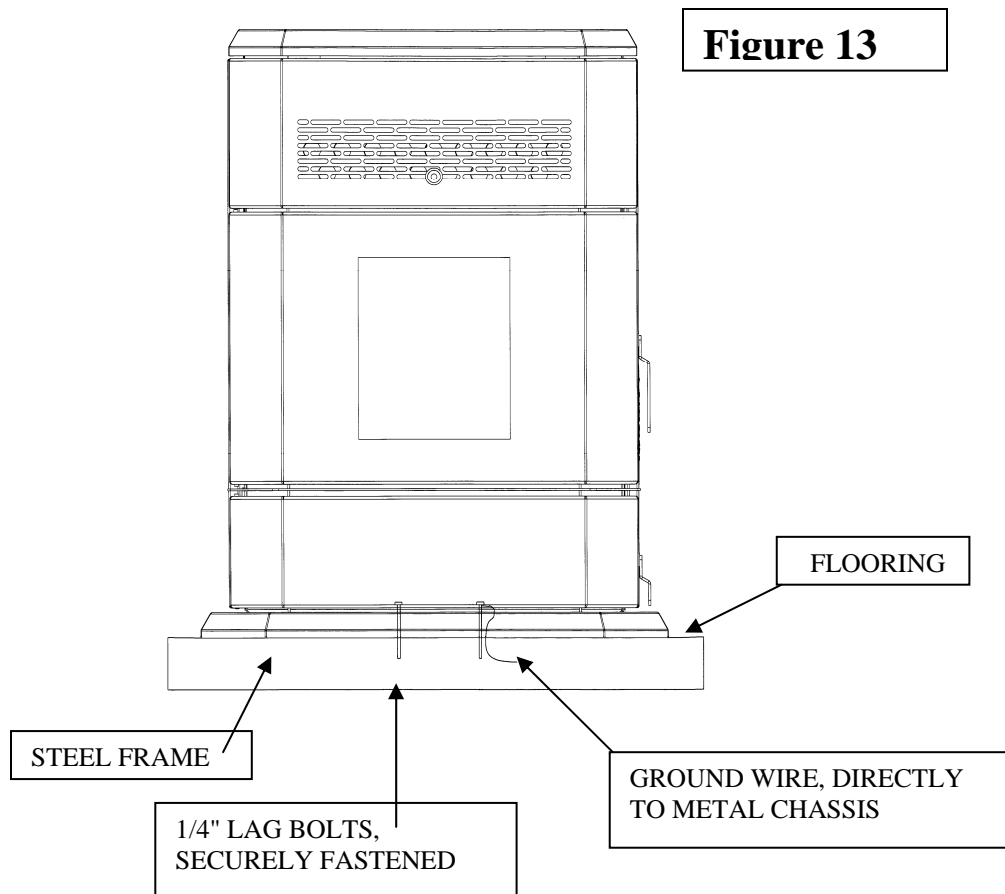
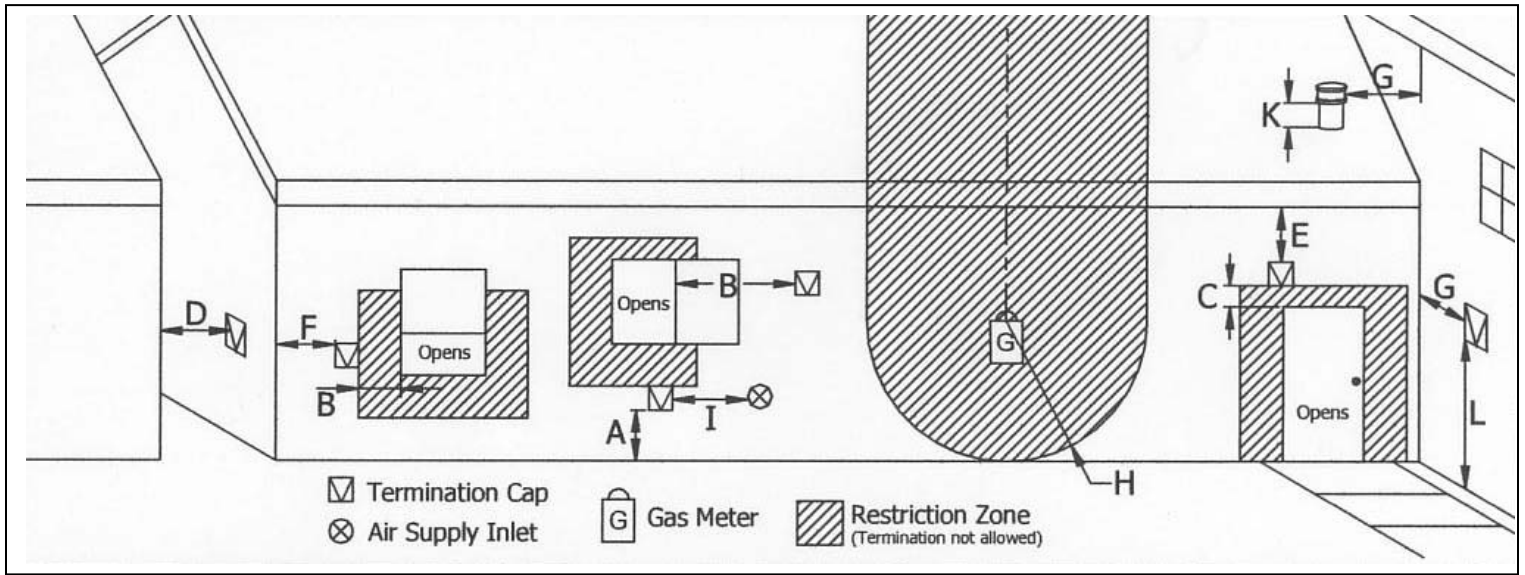

Figure 14

VENT TERMINATION LOCATIONS



Letter	Minimum Clearance	Description
A	24" (60 cm)	Above grass, top of plants wood, or any other combustible material.
B	48" (122 cm)	From beside/below any door or window that may be opened.
C	24" (60 cm)	From any door or window that may be opened.
D	24" (60 cm)	To any adjacent building, fence and protruding parts of the structure.
E	24" (60 cm)	Below any eave or roof overhang.
F	12" (30 cm)	To outside corner.
G	12" (30 cm)	To inside corner, combustible wall.
H	3' (91 cm) within a height of 15' (4.5 m) above the meter/regulator assembly	To each side of center line extended above natural gas or propane meter/regulator assembly or mechanical vent.
I	3' (91 cm)	From any forced air intake or other appliance.
J	12" (30 cm)	Clearance to non-mechanical air supply inlet to building, or the combustion air inlet to any appliance.
K	24" (60 cm)	Clearance above roof line for vertical terminations.
L	7' (2.13 m)	Clearance above paved sidewalk or paved driveway located on public property.

MAINTENANCE

FAILURE TO CLEAN AND MAINTAIN THIS UNIT AS INDICATED MAY RESULT IN POOR PERFORMANCE AND HAZARDOUS SITUATIONS. NEVER CLEAN THE UNIT WHEN HOT.

Burn Pot

Note: Let the unit cool to room temperature before inspecting the burn pot. Inspect the burn pot regularly to check that the holes have not become plugged. If necessary clean thoroughly. It is imperative that the burn pot be re-installed the correct way or the unit will not light. The back of the burn pot with the igniter hole in it (see Figure 15) must be installed facing the rear of the unit. This hole allows the igniter to heat up the pellets to the point of ignition.

Figure 15

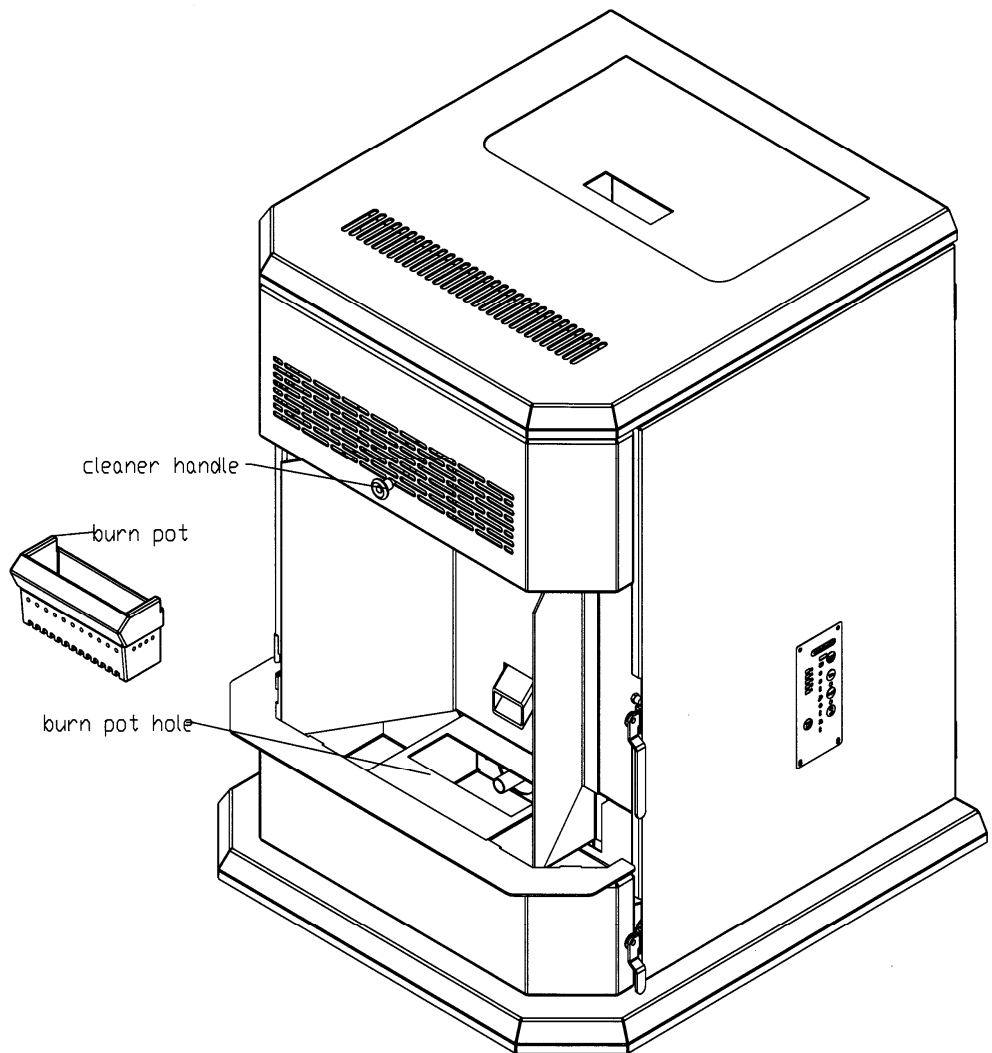

MAINTENANCE - continued

Ash Removal - Freestanding Unit

If left neglected ashes will eventually fill the ash pan. Remove the ashes periodically to avoid unnecessary ash build up. Ash removal is as follows:

1. Let fire run out and unit cool to room temperature.
2. Clean the heat exchanger tubes (see Heat Exchanger Cleaning section).
3. Open the ash pan door, remove the burn pot and burn pot liner and empty into metal container.
4. Vacuum to remove ashes from the firebox. **BE SURE THAT ASHES ARE COOL TO THE TOUCH BEFORE VACUUMING.** Some regular vacuums and shop vacs may leak ash into the room. Your vacuum or shop vac may have a special filter or bag available to eliminate this leakage.
5. Remove ash pan and dispose of ashes into metal container.
6. Reinstall ash pan.
7. Reinstall burn pot and burn pot liner.

Ash Disposal

Ashes should be placed in a metal container with a tight fitting lid. The closed ash container should be placed on a non-combustible surface or on the ground well away from all combustible materials, pending final disposal. If the ashes are disposed of by burial in soil or otherwise locally dispersed, they should be retained in the closed container until all cinders have been thoroughly cooled.

Cleaning

Heat Exchanger Tubes – Your unit is designed with a built in heat exchanger tube cleaner. This should be used every 2 or 3 days to remove ash build up on the heat exchanger tubes, which can reduce heat transfer. The handle, for the heat exchanger tube cleaner, is located inside the firebox. Slide the rod front to back several times to clean the tubes then follow the instructions for ash removal. See figure 15.

Fans – DANGER: RISK OF ELECTRIC SHOCK. DISCONNECT POWER BEFORE SERVICING UNIT.

Over time ash or dust may accumulate on the blades of the convection & combustion fans. The fans should be inspected, periodically, and if any accumulation is present vacuumed clean as the ash or dust can impede the fans performance. It is also possible that creosote may accumulate in the combustion fan, this must be brushed clean. The combustion fan can be found behind the left side panel (facing the front of the unit), the convection fan can be found behind the right side panel. To access the igniter you must remove the air inlet tube and cover (2 screws).

Note: When cleaning be careful not to damage the fan blades.

MAINTENANCE - continued

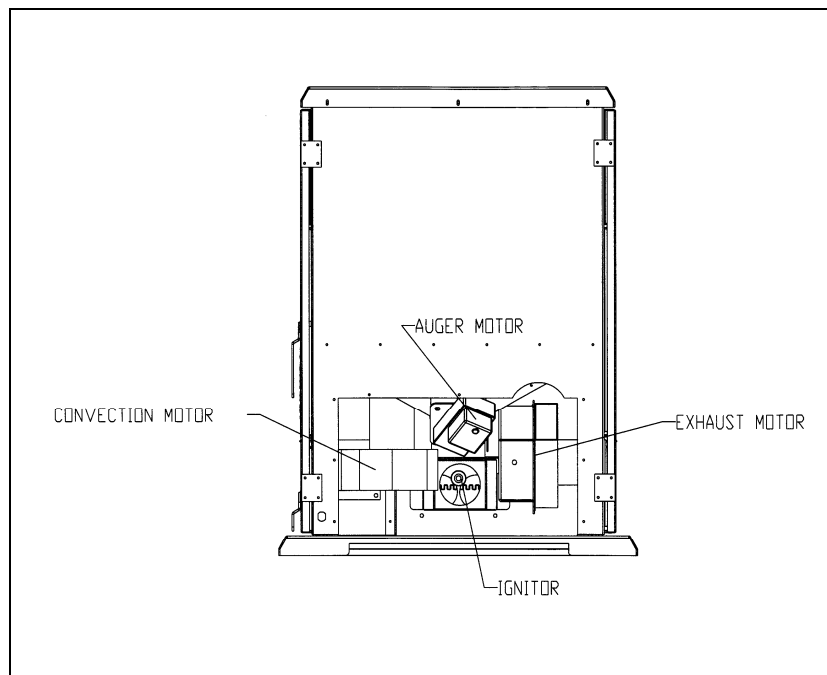

Figure 16

Chimney Cleaning:

1. **Creosote Formation** – When wood is burned slowly it produces tar and other organic vapors which combine with expelled moisture to form creosote. The creosote vapors condense in the relatively cool chimney flue, as a result creosote residue accumulates on the chimney lining. When ignited creosote makes an extremely hot fire which can damage the chimney or cause a house fire.
2. **Fly Ash** – This can accumulate in the horizontal sections of a vent run. Fly ash is non-combustible although if allowed to build up, continuously, it may impede the exhaust flow.
3. **Inspection of Vent System** – The chimney/venting system should be inspected annually or per ton of fuel to determine if creosote or fly ash build up has occurred. To clean the chimney, detach the vent where it attaches to the combustion blower. If creosote has accumulated it should be removed. Inspect the entire vent system from unit exhaust to termination. Creosote should be removed with a brush specifically designed for the type of chimney in use. It is recommended that a qualified service technician perform the inspection and required maintenance.

Glass Doors:

Gaskets around the door and window panes should be inspected, cleaned and repaired when necessary.

MAINTENANCE - continued

Door Removal and Replacement:

If glass is broken, once unit has cooled, and making sure to wear gloves, carefully remove any loose pieces of glass from the door frame. Replace only with ceramic glass obtainable from the dealer.

Task	Maintenance Schedule
Burn Pot	check daily
Combustion Chamber	weekly
Heat Exchanger Tubes	bi-weekly
Ash Pan	bi-weekly or every 10 bags of fuel
Convection Fan Blades	annually
Combustion Fan Blades	annually
Hopper	bi-weekly or every 10 bags of fuel
Venting System	annually
Glass	as needed
Gaskets	annually

TROUBLE SHOOTING

See figure 16, page 27, for component locations.

Condition 1: The unit will not light.

- Check that the unit is plugged in and that the wall outlet has power.
- Unplug the unit then check all electrical connections against the Wiring Diagram in this manual.
- Check the fuse on the circuit board.
- If a thermostat is used, ensure it is calling for heat.

If your unit still does not light contact your local dealer for service.

Condition 2: The stove will not operate when hot.

- Check the hopper has fuel.
- Check that the combustion air inlet is not blocked. Insufficient air supply may cause the fire to burn cold and may cause fuel build up, in the pot, and smother the fire.
- Check that the exhaust fan is operating, if the fan is not operating properly it may not generate enough vacuum in the firebox.
- Check the 250°F high limit switch. This switch is manually reset, check if it has tripped, if so let cool and reset switch. Check for cause of overheating, if switch trips again contact your local dealer for service.

Condition 3: Exhaust blower does not operate normally.

- Check all wiring connections.

Condition 4: Convection blower does not operate normally.

- Check all wiring connections.

Condition 5: Igniter will not light fuel.

- Check electrical connections (including fuse) to the igniter.
- Check the igniter tube, which touches the burn pot, is not plugged with ash. If it is plugged remove the debris (be sure to wait until everything has cooled to room temperature).
- Check burn pot is installed correctly (see page 24).
- If igniter still does not work, replace it.

Note: The igniter should be glowing orange when in operation.

Condition 6: The auger motor does not function normally.

- If the auger shaft does not turn but the motors armature tries to spin then this is a sign your auger is jammed. Try to remove the blockage by poking at the fuel in the drop tube. If this does not work then empty the hopper and remove the auger cover and clear the blockage (**Note: Before removing the auger cover disconnect power to the unit**).
- Check for voltage at the auger motor, if none check circuit board fuse.
- Ensure the exhaust blower is operating.

- Check the vacuum hose is connected or damaged.
- Check the manual reset on the 250° F high limit switch. If the switch has been tripped, check for the cause of the overheating, reset the switch and check if the auger operates normally.
- If the auger is not jammed and you have tried the other possible causes, connect 120 volts directly to the auger motor. If the auger motor does not work replace the auger motor.

Condition 7: The 250° F high limit switch has tripped.

- Reset the switch and determine the cause.

Condition 8: The stove will not shut off.

- Ensure that the room thermostat (if a thermostat is used) is turned down below the room temperature.
- Disconnect one of the wires to the exhaust temperature sensor, the unit should then shut off.
- Turn the control board to "OFF"

If the unit will still not shut off, disconnect power to the unit and call your local dealer for servicing.

Condition 9: The unit keeps going out on "LOW" setting.

If the unit goes out and leaves fresh unburned pellets in the burn pot liner then the fire is going out before the unit shuts off.

- On the control panel, turn the heat level up to the next setting, poorer quality pellets require a slightly higher setting.

Condition 10: Glass soots up at a fast rate, flame is lazy.

- The vent pipe (including air intake) may be dirty or partially blocked restricting airflow to the unit.
- Burn pot holes are blocked. Let the unit cool and clean burn pot and burn pot liner (be sure to follow instructions for disposal of ashes found on page 30).
- Circuit board malfunction. Time the fuel feed light at each setting (after the stove has completed the initial "Start Up" sequence. Check the timing against the timing chart (found below), if the auger motor runs constantly there is a problem with the circuit board.
- Poor fuel quality. The type of pellets being used may be of poor quality, if possible try a different brand of pellets (refer to fuel type information on page 3).

Control Board Timing		
Heat Position 1	Auger on 3 seconds	Auger off 13 sec
Heat Position 2	Auger on 5 seconds	Auger off 11 sec
Heat Position 3	Auger on 8 seconds	Auger off 8 sec
Heat Position 4	Auger on 9 seconds	Auger off 7 sec
Heat Position 5	Auger on 10 seconds	Auger off 6 sec

WIRING DIAGRAM

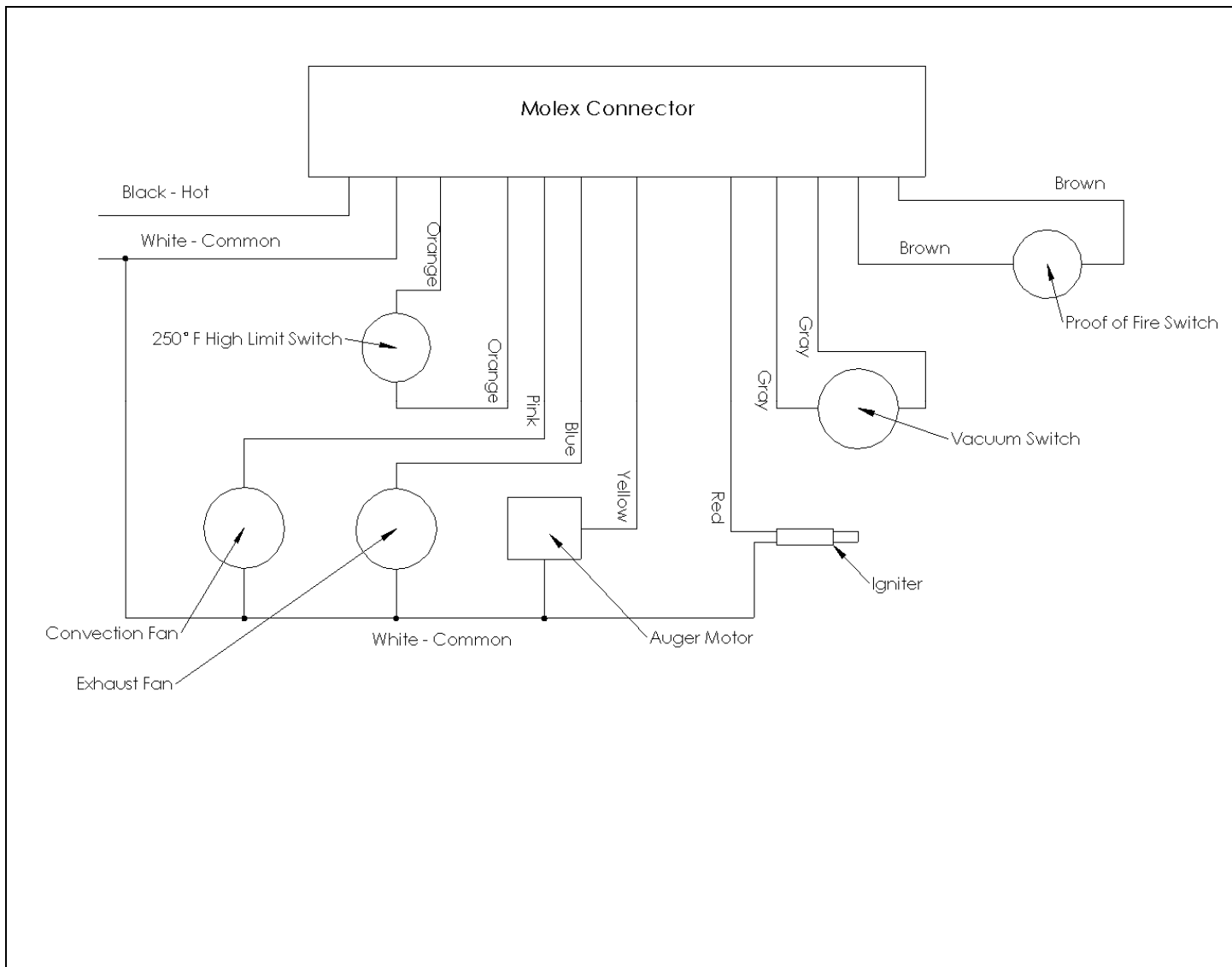

REPLACEMENT PARTS

Contact an authorized Inca Metal pellet stove dealer to obtain any of these parts. Never use substitute materials. Use of non-approved parts can result in poor performance and possible safety hazards as well as voiding the Warranty.

Item	Part #
control panel circuit board	SPSW1008
auger motor	SPSW1006
250° F, normally open high limit snap disc	SPSA1016
140° F, normally open exhaust temperature snap disc	SPSA1015
convection fan	SPSW1003
combustion fan	SPSW1001
0.1" w.c. normally open vacuum switch	SPSA1010
silicone tube for vacuum switch	SPSA1011
hot rod ignitor	SPSA1012
door gasket	SPSW1021
door glass (front panel)	SPSW1019

INCA METAL'S WARRANTY PROTECTION FOR ALL INCA METAL PRODUCTS

Inca Metal products are designed with superior components and materials, assembled by trained craftsmen who take great pride in their work. Once assembled the complete fireplace is thoroughly inspected by a qualified technician, before packaging, to ensure that you, the customer, receives the quality product that you expect from Inca Metal.

INCA METAL'S FIREPLACE'S WARRANTY

Your fireplace is guaranteed to be free of defects in materials and workmanship for a period of 5 years from the date of purchase. This covers: combustion chambers, heat exchangers and burners as well as stainless steel parts against tarnishing. Electrical components and wearable parts such as blowers, thermal switches, switches, wiring, remote controls, igniters, gaskets, and glass (thermal damage only) are covered. Inca Metal will provide replacement parts free of charge during the first year of the limited warranty.

CONDITIONS AND LIMITATIONS

Inca Metal warrants its products against manufacturing defects to the original purchaser only – i.e. the individual or legal entity (registered customer) whose name appears on the original invoice – provided that the purchase was made through an authorized Inca Metal dealer and is subject to the following conditions and limitations:

This factory warranty is nontransferable and may not be extended whatsoever by any of our representatives.

A licensed, authorized service technician or contractor must have installed the fireplace. Installation must be done in accordance with the installation instructions included with the product and all local and national building and fire codes.

This limited warranty does not cover damages caused by misuse, lack of maintenance, accident, alterations, abuse or neglect. Parts installed from other manufacturers will nullify this warranty.

This limited warranty further does not cover any scratches, dents, corrosion or discoloring caused by excessive heat, abrasives, chemical cleaners nor any venting components used in the installation of the fireplace.

This warranty does not cover any problems caused to installation used venting or vent terminations which are not certified for use with this product.

Any installation, labor, construction, transportation or other related costs or expenses arising from defective part(s), repair or replacement or otherwise of same, will not be covered by this warranty nor shall Inca Metal assume responsibility for same. Further, Inca Metal will not be responsible for any incidental, indirect or consequent damages, except as provided by law, and in no event shall they exceed the original purchase price.

CONDITIONS AND LIMITATIONS (continued)

In the first year only, this warranty extends to the repair or replacement of warranted parts, which are defective in material or workmanship provided that the product has been operated in accordance with the operation instructions and under normal conditions. Labor is not included.

After the first year, Inca Metal may, at its discretion, fully discharge all obligations with respect to this warranty by refunding to the original warranted purchaser the wholesale price of any warranted but defective part(s).

Notwithstanding any provisions contained in this warranty, Inca's responsibility under this warranty is defined as above and it shall not in any event extend to any incidental, consequential or indirect damages.

This warranty defines the obligations and liability of Inca Metal with respect to the Inca Metal fireplace and any other warranties expressed or implied with respect to this product, its components or accessories are excluded.

Inca Metal neither assumes, nor authorizes any third party to assume, on its behalf, any other liabilities with respect to the sale of this product. Inca Metal will not be responsible for: over firing, downdrafts, spillage caused by environmental conditions such as rooftops, buildings, nearby trees, hills, mountains, inadequate vents, excessive venting configurations, insufficient make up air, or negative air pressures which may or may not be caused by mechanical systems such as exhaust fans, furnaces, clothes dryers, etc.

Any damages to fireplace, combustion chamber, brass or chrome trim or other component due to water, weather damage, long periods of dampness, condensation, damaging chemicals or cleaners will not be the responsibility of Inca Metal.

The bill of sale or copy will be required together with a serial number and a model number when making any warranty claims from your authorized dealer.

Inca Metal reserves the right to have its representative inspect any product or part thereof prior to honoring any warranty claim.

Manufactured by
Inca Metal Cutting Ltd
Richmond, BC
Canada