

OWNER'S MANUAL

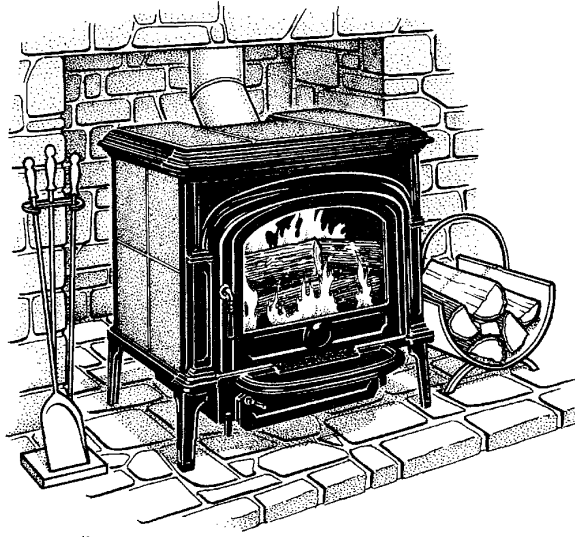

INSTALLATION AND OPERATING INSTRUCTIONS FOR **PHOENIX WOODSTOVE**

REVISED OCTOBER 1996

PLEASE READ THIS ENTIRE OWNER'S MANUAL BEFORE YOU INSTALL AND USE YOUR NEW PHOENIX WOODSTOVE. FAILURE TO FOLLOW INSTRUCTIONS MAY RESULT IN PROPERTY DAMAGE, BODILY INJURY, OR EVEN DEATH.

SAFETY NOTICE

IF THIS STOVE IS NOT PROPERLY INSTALLED, A HOUSE FIRE MAY RESULT. FOR YOUR SAFETY, FOLLOW THE INSTALLATION DIRECTIONS. CONTACT LOCAL BUILDING OR FIRE OFFICIALS ABOUT RESTRICTIONS AND INSTALLATION INSPECTION IN YOUR AREA.

MANUFACTURED BY

HearthStone®/NHC, Inc.
Stafford Avenue, P.O. Box 1069
Morrisville, VT 05661

FOREWORD

Congratulations on your recent purchase of a HearthStone® woodburning stove. You have purchased perhaps the finest solid fuel, radiant/convection heater available today. Our unique design which incorporates the natural beauty of soapstone with the elegance of porcelainized cast iron will give you years of service with minimal maintenance. We trust that you will appreciate the quality of our handcrafted product.

Please read this manual in its entirety. Its purpose is to familiarize you with your stove's safe installation, proper break-in, operation and maintenance. It contains information that will be useful to you now and in years to come, so keep it handy and refer to it as needed.

The performance of your stove depends on many variables that make your installation unique. The sections on operating procedure and general information, therefore, can only serve as useful guidelines rather than hard and fast rules.

Should you have any questions, do not hesitate to contact your dealer or the manufacturer for additional information.

You must return your warranty registration card to NHC, Inc. within 30 days of purchase in order to validate your warranty.

This stove is manufactured and warranted by:

HearthStone®/NHC, Inc.
Stafford Ave.
PO Box 1069
Morrisville, VT. 05661

SAFETY NOTICE: IF THIS STOVE IS NOT PROPERLY INSTALLED, A HOUSE FIRE MAY RESULT. FOR YOUR SAFETY, FOLLOW THE INSTALLATION DIRECTIONS. CONTACT LOCAL BUILDING OR FIRE OFFICIALS ABOUT RESTRICTIONS AND INSTALLATION INSPECTION IN YOUR AREA.

SAVE THESE INSTRUCTIONS FOR FUTURE REFERENCE!

TABLE OF CONTENTS

I	MATERIALS REQUIRED FOR A SAFE INSTALLATION	3
II	INSTALLATION	4
	A. CLEARANCES TO NON-COMBUSTIBLE SURFACES	4
	B. CLEARANCES TO COMBUSTIBLES	5
	SPECIAL NOTE FOR MOBILE HOME INSTALLATION	5
	ALCOVE INSTALLATION	5
	RESIDENTIAL AND MOBILE HOME INSTALLATIONS	6
	CLEARANCES FOR HORIZONTAL, REAR VENT	7
	CLEARANCES FOR MASONRY FIREPLACE INSTALLATIONS	7
	C. FLOOR PROTECTOR: MATERIALS AND CLEARANCES	8
	D. CHIMNEY CONNECTOR (STOVEPIPE) CLEARANCES	8
	E. VENTING SYSTEM	8
	1. CHIMNEY CONNECTOR	9
	2. CONNECTION TO A MASONRY CHIMNEY	9
	3. CONNECTION TO A PREFABRICATED METAL CHIMNEY	10
	C. OUTSIDE AIR SUPPLY	11
III	OPERATING INSTRUCTIONS	12
	A. CONTROLS AND FEATURES	12
	B. BUILDING A FIRE	12
	BREAK-IN PROCEDURE	12
	BUILDING YOUR FIRST FIRE	12
	NORMAL OPERATION	13
	BURN RATE	13
	OVERFIRE CAUTION	14
	REMOVAL AND DISPOSAL OF ASHES	14
IV	MAINTENANCE	14
	A. MONITORING STOVE TEMPERATURES	14
	B. CREOSOTE FORMATION AND NEED FOR REMOVAL	15
	C. GASKETS	15
	D. GLASS	16
	E. STONE	16
	F. CAST IRON	17
V	OPERATION GUIDELINES	17
	A. SAFETY GUIDELINES	17
	D. EMERGENCY PROCEDURES	18
	E. FIREWOOD	19
	F. OPERATING YOUR STOVE EFFICIENTLY	19
VI	TROUBLESHOOTING	20
	A. YOUR HEATING NEEDS	20
	B. OPERATING THE STOVE	21
	C. TROUBLESHOOTING GUIDE	21
VII	REPLACEMENT PARTS	23
VIII	SPECIFICATIONS	24

* * * * *

SAFETY NOTICE: IF THIS STOVE IS NOT PROPERLY INSTALLED, A HOUSE FIRE MAY RESULT. FOR YOUR SAFETY, FOLLOW THE INSTALLATION DIRECTIONS. CONTACT LOCAL BUILDING OR FIRE OFFICIALS ABOUT RESTRICTIONS AND INSTALLATION INSPECTION IN YOUR AREA.

* * * * *

I MATERIALS REQUIRED FOR A SAFE INSTALLATION

The following is a list of parts and materials required for installing this woodstove. Prevent the consequence of a house fire; do not use materials that don't meet these minimum requirements.

CHIMNEY CONNECTOR: The chimney connector (stovepipe) joins the stove to the chimney. It should be 6" (152 mm) diameter, 24 gauge minimum, metal stovepipe. Do not connect this appliance to any chimney or ducting of an air distribution system.

THIMBLE: An approved wall pass-through system is a manufactured or site-constructed device installed in combustible walls through which the chimney connector passes to the chimney. It is intended to keep walls from igniting.

CHIMNEY: The chimney can be one of two types:

Approved masonry, minimum 4" (102 mm) thickness, with at least 5/8" (16 mm) fire clay lining joined with refractory cement or other listed lining system suitable for use with woodstoves. Required lining size is 6" (152 mm) diameter or 8" X 8" (203 X 203 mm) square.

or

Prefabricated 6" (152 mm) listed high temperature (tested to 2100 degrees F or 1149 degrees C) residential type and building heating appliance chimney. Components required by manufacturers for installation such as the chimney support base, firestop (as appropriate), attic insulation shield, insulated tee, etc. are necessary to assure a safe chimney installation. Use only components manufactured for the chimney.

FLOOR PROTECTOR: 3/8" (10 mm) minimum thickness non-combustible or listed floor protector with an "R" factor of 1.0.

II INSTALLATION

Read these instructions completely before installing your stove. Avoid the possibility of a fire by installing this stove in accordance with these instructions and local building codes. Be sure to maintain the designated stovepipe and stove clearances to walls, ceilings, hearth, and other combustible surfaces.

When locating your stove, consider safety, convenience, traffic flow, and the fact that the stove will need a chimney and chimney connector. Your stove should be located away from doors and hallways in an open area to allow for necessary clearances. Review the clearance illustrations for proper measurements from combustibles.

Keep furniture, drapes, curtains, wood, paper, and other combustibles far away from the stove. Never install the stove in locations where gasoline, kerosene, charcoal lighter, or any other flammable liquids are used or stored.

You will need to purchase a reversible 45 degree elbow for the flue collar exit. By reversing the 45 degree elbow, the stove can be installed as either a *rear exit stove* (stovepipe typically exiting horizontally from the back of the stove through a wall to an exterior chimney) or a *top exit stove* (stovepipe typically exiting vertically up from the stove, through the ceiling and on up to above the roofline). Either method of installation is acceptable so long as all clearances, codes and other installation instructions are observed.

The soapstone walls of a HearthStone soapstone stove produce an even, radiant heat. Locate the stove centrally in your living area to allow the heat to travel naturally to distant rooms. It is not recommended that you locate your stove in the basement. The amount of radiant energy required to heat concrete basement walls is so great that most of the useable heat is absorbed by them and lost.

A. CLEARANCES TO NON-COMBUSTIBLE SURFACES

REFER TO NFPA 211 FOR SPECIFIC AND COMPLETE DETAILS:

National Fire Protection Agency
Batterymarch Park
Quincy, MA 02269
1-800-344-3555
1-617-770-3000

The National Fire Protection Agency has recommended, minimum clearances to non-combustible surfaces. To make a wall non-combustible, it should be protected by 4" (102 mm) (min.) masonry with a 1" (25 mm) air space between the wall and the masonry.

Another suitable wall protector is NFPA approved material (such as wonderboard) with a 1" air space between the wall and the protector. Follow the instructions and recommendations of the manufacturer of the wall protector.

Per NFPA 211, clearance to a non-combustible surface is 12" (305 mm) (from the stove to the wall behind the protection). NHC, Inc. does not recommend installations to non-combustible surfaces in alcove settings.

It is very important to follow minimum clearances for chimney connectors to combustibles such as walls and ceilings when installing the stove near non-combustible surfaces. These chimney connector clearances are outlined below in the section titled "CHIMNEY CONNECTOR (STOVEPIPE) CLEARANCES".

B. CLEARANCES TO COMBUSTIBLES

DO NOT CONNECT THIS UNIT TO A CHIMNEY FLUE SERVING ANOTHER APPLIANCE

The following information will help determine clearances which are appropriate for your installation. Close Clearance Connector Pipe is defined as listed Metalbestos, Security, Simpson-Duravent, or Ameritec close clearance type. If you use a rear heat shield to obtain reduced clearances, you must use the rear heat shield manufactured by NHC, Inc. It is available from NHC, Inc. or through your local dealer. Rear Heat Shield cannot be used without Close Clearance Connector Pipe.

SPECIAL NOTE FOR MOBILE HOME INSTALLATION

WARNING: DO NOT INSTALL IN SLEEPING ROOM

CAUTION: THE STRUCTURAL INTEGRITY OF THE MOBILE HOME FLOOR, WALL, AND CEILING/ROOF MUST BE MAINTAINED.

Stove must be equipped with the optional Outside Air Kit available through your dealer.

ALCOVE INSTALLATION

CLOSE CLEARANCE CONNECTOR PIPE AND REAR HEAT SHIELD

For alcove installations, the stove can only be placed parallel to the surrounding walls. A close clearance connector pipe and the optional rear heat shield **must** be used.

The minimum alcove size:

- 72" (1829 mm) high
- 95" (2413 mm) wide
- 36" (914 mm) maximum depth.

Parallel Installation:

- Rear = 21 1/2" (547 mm)
- Side = 24 1/2" (623 mm)*
- Stovepipe = 10" (254 mm)

*REFER TO FIGURE BELOW: "A" can be a minimum of 24 1/2" (578 mm) on one side **or** the other. However, "B" must **never** be less than 95" (2413 mm).

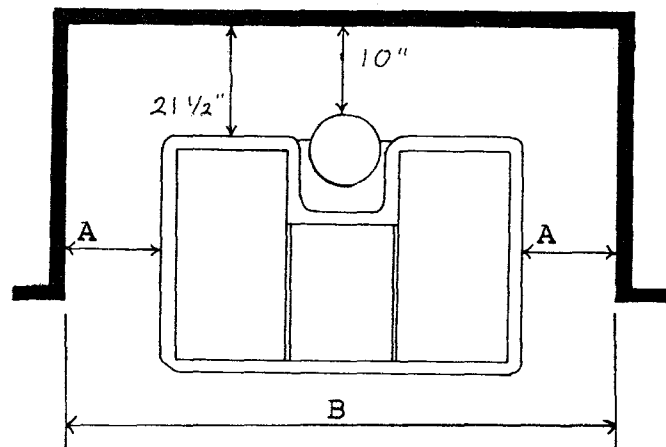

RESIDENTIAL AND MOBILE HOME INSTALLATIONS

RESIDENTIAL
SINGLE WALL CONNECTOR PIPE (24 GAUGE PIPE)

Parallel Installation:

- Sidewall to Stove 24 1/2" (623 mm)
- Backwall to Stove 24 1/2" (623 mm)
- Backwall to Pipe 21" (533mm)

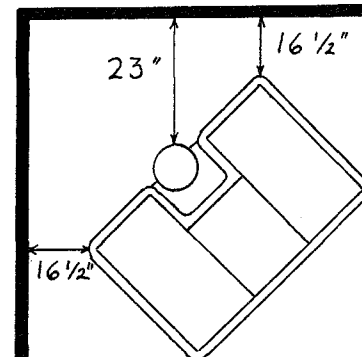
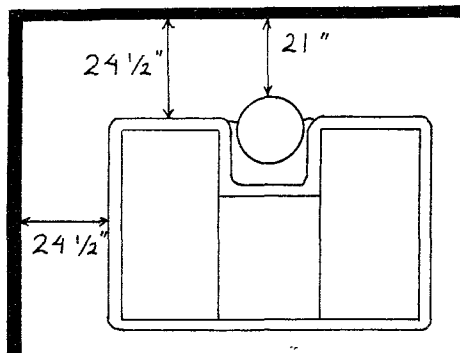

Corner Installation:

- Wall to Stove Corner 16 1/2" (420mm)
- Wall to Pipe 23" (584mm)

RESIDENTIAL
CLOSE CLEARANCE CONNECTOR PIPE

Parallel Installation:

- Sidewall to Stove 22 3/4" (578 mm)
- Backwall to Stove 14" (356 mm)
- Backwall to Pipe 10" (254mm)

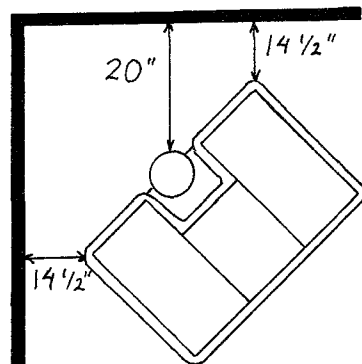
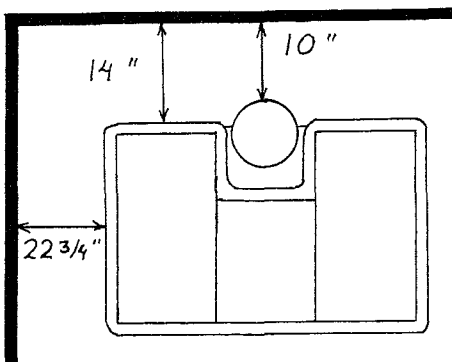

Corner Installation:

- Wall to Stove Corner 14 1/2" (369mm)
- Wall to Pipe 20" (508mm)

RESIDENTIAL AND MOBILE HOME
CLOSE CLEARANCE CONNECTOR PIPE AND REAR HEAT SHIELD

Parallel Installation:

- Sidewall to Stove 22 3/4" (578 mm)
- Backwall to Stove 12" (305 mm)
- Backwall to Pipe 8" (204mm)

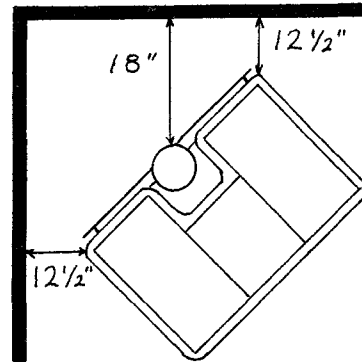
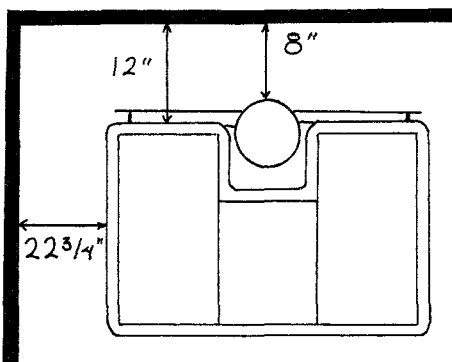

Corner Installation:

- Wall to Stove Corner 12 1/2" (318mm)
- Wall to Pipe 18" (458mm)

CLEARANCES FOR HORIZONTAL, REAR VENT

RESIDENTIAL

SINGLE WALL CONNECTOR PIPE (24 Gauge Pipe)

Parallel Installation:

Sidewall to Stove = 24 1/2" (623 mm)

Backwall to Stove = 24 1/2" (623 mm)

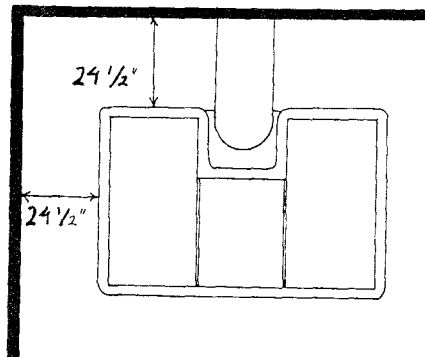

RESIDENTIAL AND MOBILE HOME CLOSE CLEARANCE CONNECTOR PIPE AND REAR HEAT SHIELD

(Pipe must be equipped with a spark arrester)

Parallel Installation

Sidewall to Stove = 22 3/4" (578 mm)

Backwall to Stove = 12" (305 mm)

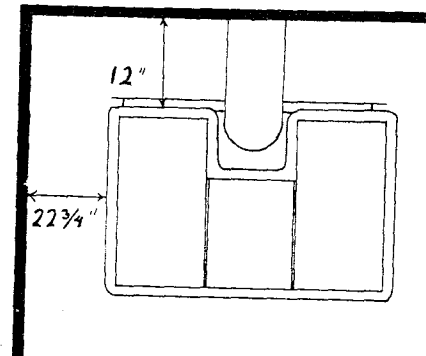

CLEARANCES FOR MASONRY FIREPLACE INSTALLATIONS

The Phoenix can be installed into an existing masonry fireplace. The existing fireplace must be built to UBC Chapter 37. Do not remove brick or mortar from the fireplace to accommodate the stove. The flue outlet must be connected directly to the chimney flue. The chimney flue must have an inside diameter of 6" (152 mm) or a measurement of 8" X 8" (203 X 203 mm). **DO NOT** set any part of the stove inside the fireplace opening. To do so would void all recommended clearances and may cause a house fire.

MINIMUM CLEARANCES:

Side Wall	25" (635 mm)
Side Trim	12" (305 mm)
Top Trim	12" (305 mm)
Mantel	28" (711 mm)

HEARTH REQUIREMENTS:

Refer to the above section titled "FLOOR PROTECTOR; MATERIALS AND CLEARANCES" to determine an acceptable floor protector. The hearth must extend 16" (406 mm) beyond the front and 8" (203 mm) beyond each side of the stove.

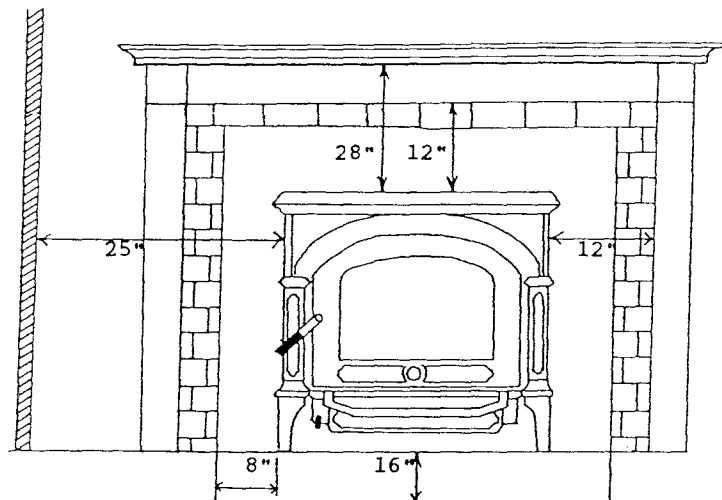

or ceiling to a prefabricated chimney. These accessories are absolutely necessary to provide safe clearances to combustible wall and ceiling material.

This stove may be connected to a lined masonry chimney or an approved high temperature prefabricated residential type building heating appliance chimney. Do *not* connect this stove to a chimney serving another appliance as doing so will affect the safe operation of both appliances.

1. CHIMNEY CONNECTOR

The chimney connector must be 6" (152 mm) diameter, 24 gauge stovepipe. Do not use aluminum or galvanized steel pipe as they cannot properly withstand the extreme temperatures of a wood fire.

Do not use stovepipe as a chimney. You must connect your stove to a chimney comparable to those recommended in this manual. Stovepipe (the chimney connector) is to be used only to connect the stove to a proper chimney.

Stovepipe sections must be attached to the stove and to each other with the crimped end toward the stove. In the event of a creosote buildup this allows the creosote to run into the stove and not the outside of the stovepipe and onto the stove.

All joints, including the connection when the stovepipe attaches to the stove's flue collar, must be secured with three sheet metal screws. Failure to properly secure the connections may result in joint failures with the stovepipe vibrating apart in the event of a creosote chimney fire. Holes pre-drilled in the flue collar accept 1/8" X 1/2" (3 mm x 13 mm) sheet metal screws.

Additional stovepipe accessories such as draw-bands, slip-joints and clean-out tees greatly simplify the installation of stovepipe from the stove to the chimney, making inspection easier. These accessories also allow for easy dismantling of the stovepipe, without having to moving the stove, for periodic inspection of the stovepipe connector and chimney.

For proper stove operation, the stovepipe connecting the stove to the chimney should be as short as possible. Avoid too many elbows. Horizontal lengths of stovepipe should have an upward slope from the stove of at least 1/4" per foot (21 mm/m). Because of the air control design of this product, a stovepipe damper is not necessary.

2. CONNECTION TO A MASONRY CHIMNEY

There are two primary elements to consider when connecting a stove to a masonry chimney, the *chimney* itself and the *thimble*, where the stovepipe connect to the chimney.

Prior to connecting a stove to a masonry chimney, the chimney should be examined for cracks, loose mortar, other signs of deterioration and blockage. The stove should not be installed until it is determined that the chimney is safe for use. If repairs to the chimney are required, they should be completed before the stove is put into service.

A 2" (51MM) air space around an interior masonry chimney must be maintained as the chimney passes upwards through the building to allow natural heat removal from the area. Insulation in this space will cause a heat build-up which may ignite wood framing.

An oversized flue will contribute to the accumulation of creosote. Therefore, the size of the flue should be checked to determine that it is not too large for this stove. This stove requires a flue no larger than 8" X 8" (203 mm x 203 mm) or 6" (152 mm) round.

The following is a checklist of minimum requirements for masonry chimneys:

-Chimney wall construction:

- Brick or modular block at least 4" (102 mm) thick.
- A rubble or stone wall at least 12" (305 mm) thick.

-Must have a fire clay flue liner:

- Minimum thickness of 5/8" (16 mm).
- Installed with refractory mortar.
- At least 1" (25 mm) air space.
- An equivalent flue liner must be a listed chimney liner system or other approved material.

-Interior chimney requirements:

- At least 2" (51 mm) clearance to combustible structure.
- Fire stops must be installed at the spaces where the chimney passes through floors and/or ceiling.
- Insulation must be 2" (51 mm) from the chimney.

-Exterior chimney requirements:

- At least 1" (25 mm) clearance to combustible structure.

-Chimney height requirements:

- At least 3 feet (0.91 m) higher than the highest part of the roof opening through which it passes and at least 2 feet (0.61 m) higher than any part of the roof within 10 feet (3 meters) measured horizontally from the top of the chimney. This stove requires a minimum chimney height of 13 feet (4 m).

A *thimble* must be used when the connection from the stove to a masonry chimney is made through a combustible wall. There are several methods to use for connection through a combustible wall. Local building authorities should be consulted for referencing proper methods of chimney connection.

Approved prefabricated metal thimbles can be purchased for connection of woodstoves to an existing masonry chimney. The manufacturer's installation instructions must be strictly followed to assure the safety of the system. Be sure to maintain the designated clearance to combustible materials.

3. CONNECTION TO A PREFABRICATED METAL CHIMNEY

When a prefabricated metal chimney is used, the manufacturer's installation instructions must be followed precisely. Only Class A 103 H.T., solid insulation type prefabricated metal chimneys may be used with this stove.

When installing a prefabricated chimney you must also purchase (from the same manufacturer) and install the ceiling support package or wall pass-through and "T" section package, firestops (when needed), insulation shield, roof flashing, chimney cap, etc. Follow the instructions provided by the manufacturer and maintain all proper clearances to the structure as recommended by the manufacturer.

There are basically two methods of prefabricated metal chimney installation:

- 1) An *interior* installation where the chimney passes inside the residence through the ceiling and roof.
- 2) An *exterior* installation where the chimney passes through the wall behind the stove then up the outside of the residence.

In all cases an interior chimney is recommended if possible. An interior chimney heats up more quickly and retains its heat, which both promotes a better draft and discourages the formation of creosote. An exterior chimney does not benefit from the warmth of being surrounded by the building so it typically operates at lower flue temperatures than an interior chimney. An exterior chimney typically does not have as strong a draft as an interior chimney and may experience increased creosote accumulation.

Height requirements for a prefabricated metal chimney are the same as for a masonry chimney: At least 3 feet (0.91 m) higher than the highest part of the roof opening through which it passes and at least 2 feet (0.61 m) higher than any part of the roof within 10 feet (3 meters) as measured horizontally from the top of the chimney. This stove requires a minimum chimney height of 13 feet (3.9 m).

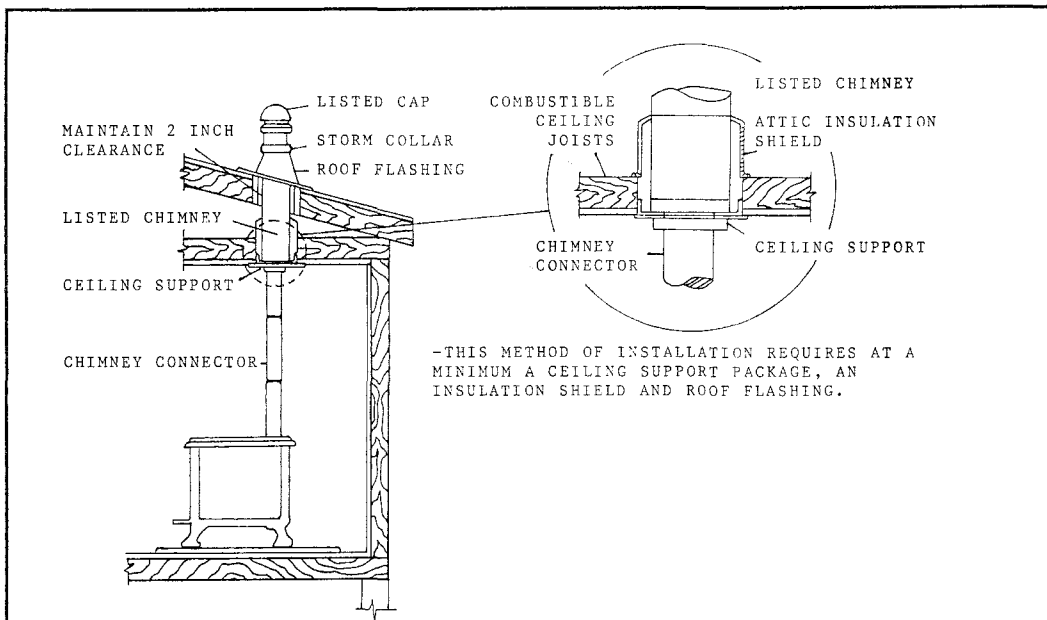

TYPICAL PREFABRICATED CHIMNEY INSIDE THE HOUSE

C. OUTSIDE AIR SUPPLY

An outside air source may be connected directly to this stove using an optional outside air kit. The advantage of providing outside air directly to the stove is that the air used by the stove for combustion is taken from outside of the residence rather than from within the room where the stove is located. With outside air supplied directly to the stove drafts within the room and air infiltration within the building are reduced. Use of the outside air kit may also improve stove performance in a particularly air tight house.

The outside air kit for this stove allows for the direct connection of the stove's air intake to a minimum 3" (76 mm) diameter duct (supplied by others) which leads to the outside of the house. When considering placement of the duct from the outside of the house to the hearth keep in mind the need to avoid structural members of the house and that the duct should terminate at the lower, center portion of the hearth. Connection of the duct to the stove is made on the lower, center section of the stove's rear wall. The termination of the duct on the outside wall of the stove should be located in such a manner so as to preclude the possibility of obstruction by snow, leaves or other material and should be screened against animals and insects.

III OPERATING INSTRUCTIONS

A. CONTROLS AND FEATURES

You should become familiar with the location and operation of your stove's controls and features. Do not modify these features in any way.

PRIMARY AIR CONTROL: Located on the lower left side of the stove, under the ashlip, the primary air control regulates the amount of air entering the firebox. Generally speaking, the more air allowed into the firebox, the faster and hotter the rate of burn.

ASH PAN: The ash pan and ash pan access door are located under the ashlip. The firebox should be cleared of ashes daily by sliding the ash grate sideways, sifting the ashes across the grate into the ash pan, then returning the grate to its closed position. The ash pan is easy to remove and has a handle for convenient disposal of ashes. The ash level within the firebox should be maintained at the proper level. Too much ash will inhibit the efficient and complete combustion of the firewood whereas too little ash will expose the bottom of the firebox to excessive direct heat from the fire. The firebox should ideally contain a 1-to-2" (25-to-51 mm) layer of ash on top of which the fire burns.

NOTE: The back of the ash pan assembly is sloped upwards. Before removing the ash pan, push it (hard!) into the stove to force the pan up the slope which kicks the ashes further into the pan.

B. BUILDING A FIRE

CAUTION: DO NOT USE CHEMICALS OR FLUIDS TO START A FIRE. DO NOT BURN GARBAGE OR FLAMMABLE FLUIDS SUCH AS GASOLINE, NAPHTHA, KEROSENE, CHARCOAL LIGHTER FLUID OR ENGINE OIL.

BREAK-IN PROCEDURE

It is imperative that your stove be "broken in" slowly. Cast iron must be "seasoned"; overfiring a new stove may cause castings to crack or may damage other stove parts. Moisture in the soapstone must be driven out slowly to minimize the "shock" to the stove of its first exposure to high firebox temperatures. Also, the asbestos-free furnace cement must be cured slowly to insure adequate sealing and bond. The first two or three fires in your new stove will also cause the high temperature paint to give off a strong odor and some smoke. The odor and smoke will end once the break-in period is over.

The bottom layer of firebrick in your firebox is intended to prevent thermal stress and should remain in place in the firebox at all times.

BUILDING YOUR FIRST FIRE

1. Open the door and place five or six double sheets of tightly twisted newspaper in the center of the firebox. Arrange kindling in a criss-cross pattern over the newspaper. Kindling should be approximately ten pieces, 1/2" (13 mm) in diameter and 10" to 18" (254 mm to 457 mm) long.
2. Fully open the primary air control by rotating the control handle fully counterclockwise.
3. Light the paper under the kindling. Leave the front door slightly ajar momentarily until the kindling has started to burn and draft begins to pull.
4. Close the door and allow the fire to burn. Keep the door and ash drawer closed while the stove is in use.
5. **KEEP A WATCHFUL EYE ON YOUR STOVE** to maintain a steady, low-heat fire. Your first and subsequent break-in fires should make the stove warm but not hot to the touch. At most,

- a few small chunks of wood should be added to the fire to reach safe break-in temperatures.
6. Once the stove is warm but not hot to the touch close the primary air control and allow the fire to die out completely.
 7. Let the stove return to room temperature.

Your first three break-in fires should be build and maintained as outlined above. Your patience will be rewarded by a properly seasoned stove.

NOTE: Because of the cool flue gas temperatures present during the break-in procedure, creosote may build up quickly. We recommend a visual inspection (and cleaning if necessary) of your stovepipe and chimney once the break-in procedure is completed.

NORMAL OPERATION

If your stove is not used continuously or has not been used in quite some time, follow the break-in procedure at least once to minimize the stress of a hot fire on a cold stove before proceeding with normal operation. We recommend one break-in fire at the start of each heating season.

To build a fire for everyday use:

1. Open the door and place five or six double sheets of tightly twisted newspaper in the center of the firebox. Arrange kindling in a criss-cross pattern over the newspaper. Kindling should be approximately ten pieces, 1/2" (13 mm) in diameter and 10" to 18" (254 to 457 mm) long.
3. Fully open the primary air control by rotating the control handle fully counterclockwise.
4. Light the paper under the kindling. Leave the front door slightly ajar momentarily until the kindling has started to burn and draft begins to pull.
6. Close the door and allow the fire to burn.
7. Once the kindling is burning, open the door and add logs, small at first, to build the fire up. Make sure to keep the logs away from the glass in front in order for the airwash system to work properly. Otherwise, keep the door and ash drawer closed while the stove is in use.
8. Once the fire is burning well, use the primary air control to regulate the desired rate of burn. Turn the primary air control counterclockwise for a high rate of burn or clockwise for a low rate of burn.

Note: Whenever opening the door to reload, re-arrange logs, or whatever, it is advisable to open the door just a crack, pause for a moment, then open the door completely. This procedure will allow the firebox to clear of smoke before the door is opened fully. Also, reloading on a bed of hot, red coals reduces smoking time and will bring fresh fuel up to a high temperature rapidly.

BURN RATE

HIGH BURN: Fully load the firebox with wood on a bed of hot coals or on an actively flaming fire and fully open the primary air control. A high burn rate is recommended once or twice a day to fully heat the stovepipe and chimney which will help minimize creosote accumulation.

MEDIUM BURN: Set the primary air control to a mid-range setting appropriate for the heating needs of the area being heated. A medium burn rate should be the typical setting and is preferable if the stove is to be left unattended.

LOW BURN: Close the primary air control for a low burn rate. A low burn rate over extended periods of time is not advisable as it may promote the accumulation of creosote. The venting system should be inspected frequently if low burn rates are maintained consistently.

OVERFIRE CAUTION

Overfiring means operating your stove at excessively high temperatures for extended periods of time. Overfiring should be carefully avoided as it can cause damage to the stove. The surest indication of overfiring is when the stove creaks and glows and when enameled surfaces bubble. Evidence of overfiring is warping and/or failure of internal parts, discolored external cast iron, or damaged enamel. Blistering or bubbling of enameled parts is caused when the temperature of the enamel is in excess of 900 F (480 degrees C).

Do not overfire the stove or operate the stove with the door open. Doing so could overheat the stovepipe and chimney which could ignite creosote in the chimney leading to a chimney fire. In the case of an overfire or a chimney fire, close the door and close the primary air control completely.

NOTE: ANY SYMPTOMS OF OVERFIRING WILL VOID YOUR WARRANTY!!

REMOVAL AND DISPOSAL OF ASHES

To remove ashes from the firebox, slide the ash grate sideways sifting the ashes across the ash grate using a poker or other suitable implement. Be sure to return the ash grate to its closed position leaving a small layer of ash.

Do not remove all ashes from the firebox as the ash level should be maintained at the proper level. Too much ash will inhibit the efficient and complete combustion of the firewood whereas too little ash will expose the bottom of the firebox to excessive direct heat from the fire. The firebox should ideally contain a 1-to-2" (25-to-51 mm) layer of ash on top of which the fire burns.

Ashes should be dumped from the ash drawer into a metal container with a tight fitting lid. Do not place any other items or trash into the metal container. Replace the lid onto the container and allow the ashes to cool. Do not place the ash disposal container on a combustible surface or vinyl flooring as the container will be hot!

Pending disposal, place the closed ash container on a noncombustible floor or on the ground, well away from all combustible materials. Ashes should be retained in the closed container until all cinders have thoroughly cooled.

Ashes should NEVER be placed in wooden or plastic containers, or in paper or plastic bags, no matter how long the fire has been out. Coals within a bed of ashes can remain hot for several days once removed from the firebox.

IV MAINTENANCE

A. MONITORING STOVE TEMPERATURES

Monitor the stove temperatures with a stove thermometer placed on the top center stone of the stove. The thermometer should read approximately 800 degrees F (427 degrees C) on high burn and 300-400 degrees F (149-204 degrees C) on low burn.

After loading your stove, open the primary air control for 20 minutes to invigorate the fire and to permit burn-off of creosote which may have accumulated over a period of time at a low burn setting.

Do not overfire the stove.

B. CREOSOTE FORMATION AND NEED FOR REMOVAL

When wood is burned, it produces tar, water vapor, and other organic vapors. These vapors condense and form creosote on the walls of chimneys which are cool due to newly started fires, low burn rates or poor chimney design. If ignited, this creosote residue makes an extremely hot fire which may damage the chimney or even destroy the house.

To prevent the buildup of creosote:

1. Burn the stove with the primary air control fully open for 35 to 45 minutes daily to burn out creosote deposits from within the stove and the venting system.
2. After reloading with wood, burn the stove with the primary air control fully open for 20 to 30 minutes. This manner of operation ensures early engagement of the secondary combustion system which, when engaged, minimizes creosote buildup in the chimney.

The stovepipe connector and chimney should be inspected at least twice monthly during the heating season to determine if a creosote build-up has occurred. If a creosote residue greater than 1/4" (6 mm) has accumulated, it should be removed to reduce the risk of a chimney fire.

The venting system must be inspected at the stove connection *and* at the chimney top. Cooler surfaces tend to build creosote deposits quicker, so it is important to check the chimney at the top (where it is coolest) as well as from the bottom near the stove.

Accumulated creosote should be removed with a cleaning brush specifically designed for the type of chimney in use. A chimney sweep can perform this service.

It is also recommended that before each heating season the entire system be professionally inspected, cleaned and repaired, if necessary.

C. GASKETS

Gasket material should normally be replaced every two to three seasons, depending on stove use. If the door seal is loose, a new gasket will assure a tight seal and improved stove performance. Contact our Customer Service Department or your dealer for a gasket kit which includes instructions and gaskets for your stove.

The procedure for replacing gaskets on the glass is reviewed in Section D, GLASS.

To replace door gaskets, first remove the old gaskets with a utility or putty knife. Clean all gasket channels with a wire brush. Apply gasket cement to the channels and push the new gasket into place without stretching the gasket material. The door should be shut immediately to fully press the gasket into place assure a positive seal.

We require the use of the following gaskets:

- | | |
|-----------|--|
| GLASS: | 54" (1.4 m) Length, 3/4" (19 mm) Wide, Adhesive Backed Black Tape |
| DOOR: | 60" (1.5 m) Length, 1/4" (6 mm) Diameter, Low Density Black Tube |
| ASH DOOR: | 30" (0.76 m) Length, 1/4" (6 mm) Diameter, Low Density, Black Tube |

D. GLASS

Do not operate the stove with a broken door glass. Do not abuse the front door by striking or slamming.

The glass can be cleaned with commercial glass cleaners, or straight ammonia. The edge of a new utility knife blade can be used to scrape stubborn creosote from the glass surface.

The front door glass is a ceramic, shock-resistant glass, made specifically for use in woodstoves. It measures 15-7/8" x 11-3/8" (403 mm x 289 mm) and is 5 mm thick. Do NOT use any replacement glass other than glass manufactured and supplied specifically for use in woodstoves.

The door glass should be replaced immediately if broken. Contact our Customer Service Department or your local dealer for replacement glass which is accompanied with instructions and everything needed for the repair.

The procedure for glass and glass gasket replacement is as follows:

1. Remove the door by lifting it straight up off the hinges with the hinge pins remaining in the door.
2. Place the door face down on a flat, smooth surface.
3. Remove the window frame screws to separate the window frame from the door.
4. Carefully lift the glass from the door.
5. Apply the new gasket to the new glass as illustrated to form a cushion on one side of the glass.
6. Place the gasketed glass onto the door with the cushion of gasket facing down towards the door.
7. Replace and screw the window frame back to the door.
8. Replace the door.

ILLUSTRATION OF HOW TO GASKET THE GLASS:



E. STONE

Occasional cleaning is all that should be necessary to maintain the natural beauty of your stove's polished soapstone finish. Clean the soapstone with water, any non-abrasive cleaner and a soft cloth. Wipe dust from the stone with a clean cloth. Do not use chemical agents to wash the stone; do not use waxes or any polishing agents on the stone.

Care must be taken not to scratch or chip the stone. Do not set items which can scratch or chip the stone (or enamel finish) on top of your stove.

Often, with use and over time, subtle earth tones of brown, red, and yellow appear on the soapstone. This is a natural reaction in the soapstone.

F. CAST IRON

Exterior cast iron parts are either painted with black, high-temperature stove paint or porcelainized with an enamel finish in various colors.

Use this black, high-temperature stove paint to touch up and maintain the original appearance of painted cast iron. When using a damp sponge to wipe clean, dry the cast iron thoroughly to prevent rusting.

Enamel castings can be cleaned with a standard glass cleaner. With time and use, a very fine, subtle network of crazed lines may appear seemingly beneath the surface of the enamel. Crazing is a natural predictable process and does not represent a flaw.

V OPERATION GUIDELINES

A. SAFETY GUIDELINES

DO

- Read and understand this Owner's Manual thoroughly before installing this stove.
- Install the stove according to the manufacturer's recommendations.
- Install this stove in accordance with all applicable codes.
- Install this appliance with the proper sized chimney.
- Follow recommended break-in procedure as outlined in this manual.
- Burn natural wood only. Higher efficiencies and lower emissions result when burning air dried, seasoned hardwoods, as compared to green or freshly cut hardwoods.
- Use caution when loading firewood into a hot stove.
- Keep the front door closed at all times except when loading wood.
- Warn children and others unfamiliar with woodstoves of the danger of touching hot, radiating surfaces. Hearth and stove guards may be obtained through your local dealer.
- Inspect the stove pipe, chimney connector and chimney frequently, as recommended.
- Be sure the removable ash lip is in place while burning the stove as it was certified for operation. Otherwise, the hearth may exceed safe temperatures.

DON'T

- Modify this product in any way, including the primary air control system.
- Expect the stove to heat more than 50% of the recommended volume if installed in a basement or in any area with a large portion of uninsulated masonry walls.
- Burn kiln dried, painted or treated wood, solvents, trash, plywood, colored or glossy paper, artificial logs, cardboard, coal, garbage or driftwood.
- Burn coal in this stove.
- Use chemical fire starters or chemical chimney cleaners.
- Use gasoline, kerosene or other liquid fuels to start or invigorate the fire.
- Burn the stove with the ash door open or the grate plug removed.
- Elevate the fire up off the firebrick.
- Allow logs to rest against or otherwise come in contact with the glass when the door is closed.
- Slam the door.
- Let the stove burn without the removable ash lip in place while burning the stove as it was certified for operation. Otherwise, the hearth may exceed safe temperatures.

OTHER SAFETY GUIDELINES

1. Always keep all combustible items (furniture, drapes, clothing, etc.) a minimum of 36" (0.92 m) from the stove.
2. Do not overfire your stove.
3. Install a smoke alarm.
4. Keep a fire extinguisher handy. We recommend the type rated "A B C."
5. Dispose of ashes properly.
6. NEVER use gasoline type fuel, kerosene, charcoal lighter fluid or similar liquids or solid fire starters to start or invigorate a fire. Keep all such materials away from the stove.
7. Keep children and pets away from the stove.
8. NEVER put articles of clothing or candles on a hot stove.
9. Do not connect the stove to a flue that is serving another appliance.
10. Clean your system when as needed.

PERIODIC CHECKLIST

EVERY WEEK

-Empty ashes from the firebox and ash pan.

EVERY TWO WEEKS

-Visually inspect chimney connector and chimney for creosote; clean accordingly.

EVERY EIGHT WEEKS

-Check door seals using the "dollar bill test." When the fire is out and the stove cool, shut the door on a dollar bill. If the bill pulls out easily, the door isn't sealed properly. Change the door gasket.

AT SEASON'S END

-Dismantle chimney connector and clean thoroughly; replace any pieces that show signs of rust or deterioration.

-Inspect and, if necessary, clean your chimney.

-Thoroughly clean out the inside of the stove.

-Inspect all door gasket material and replace if worn, frayed, cracked or extremely hard.

D. EMERGENCY PROCEDURES

In the event of a stovepipe or chimney fire follow these instructions:

1. Close the primary air control.
2. Keep the stove door shut.
3. Call the fire department.
4. Keep an eye on the stove, stovepipe, and chimney.

Do NOT attempt to extinguish a stovepipe or chimney fire by throwing water onto the stove, stovepipe or chimney. The extremely high temperatures associated with such fires can cause instantaneous steam and serious bodily harm.

Once the chimney fire has expired, leave the primary air control closed and let the fire in the stove die out completely. The stove should not be fired again until the stove, stovepipe, and chimney are all thoroughly inspected for any sign of damage. Damage must be corrected before resuming use of your stove.

E. FIREWOOD

The quality of your firewood is an important variable which affects heat output, duration of burn and stove performance. Softwoods generally burn hotter and faster, while hardwoods burn longer and produce more coals.

The density of the wood is one critical factor to consider when either purchasing wood or assessing your stove's performance. The following is a list of wood species and their relative BTU content.

HIGH: Ash, Black Birch, Hickory, Hophorbeam, Locust, White Oak, Black Beech

MEDIUM HIGH: White Ash, Beech, Yellow Birch, Sugar Maple, Red Oak

MEDIUM LOW: Black Ash, White Birch, Grey Birch, Elm, Norway Pine, Pitch Pine, Black Cherry, Soft Maple, Tamarack

LOW: White Pine, White Cedar, Balsam Fir, Spruce, Aspen, Basswood, Butternut, Hemlock

Moisture content also plays a key role in the performance of your stove. Wood freshly cut from a living tree (green wood) contains a great deal of moisture. To properly season green wood, it should be split, stacked and allowed to air dry for a period of one year.

Ideally, firewood should be stacked on skids or blocks to keep it off the ground, and only the top of the stack should be covered. Plastic or tarps that cover the sides of the woodpile trap moisture and prevent the wood from drying. As for stacking, an old Vermonter said, "The spaces between the logs should be large enough for a mouse to get through, but not for the cat that's chasing it."

Firewood should not be stored within the stove's specified clearances to combustible materials.

F. OPERATING YOUR STOVE EFFICIENTLY

This stove is designed to burn firewood efficiently. The following operational tips will provide you with information on how to obtain the most heat possible with minimal creosote build-up and emitted pollutants.

HIGH HEAT: For maximum heat output, fully load the stove after the fire has been established and both the stove and chimney are hot. The primary air control should be at or close to the fully open position. When first engaging the stove in the high heat burn mode, monitor the stove temperatures frequently to ensure that the stove is not overfired. Once familiar with the operational characteristics of the stove in your particular setting you will easily engage the stove in the high burn mode without risk to the stove or chimney.

Once the temperature of the room is at a comfortable level, subsequent loadings of the stove should be of smaller quantities of wood. Burning smaller amounts of wood at a high rate of burn will result in the most efficient burn, the least emissions of pollutants and the least accumulation of creosote in the chimney.

OVERNIGHT BURN: The stove and chimney must be hot with an established fire prior to attempting an overnight burn. For an overnight burn, completely load the firebox with wood and, with the primary air control in the fully open position, allow the fire to burn intensely for 20 to 30 minutes. Now lower the primary air control to close to its lowest setting; the fire should settle into a low burn pattern with a small flame burning at a slow rate. The fire will now burn at a slow, steady rate for 7 to 9 hours depending on the primary air control setting, the type of wood being burned, the strength of the chimney draft and other variables which vary from installation to installation.

In the morning you should find a bed of hot coals buried within the ashes. The stove should be warm to the touch but not hot. To restart the fire without relighting, simply stir and rake the ashes with a poker until the hot coals have come to the surface. Place a handful of kindling on the coals, close the door and fully open the primary air control. The fire should reignite within 5 to 10 minutes. Place a few logs on the burning kindling, close the door, leave the primary air control fully open and allow the logs to ignite. Once the fire is burning briskly, regulate the primary air control to a medium setting for a moderate burn rate.

As it is recommended that you burn a hot fire at least once a day to burn off accumulated creosote from within the stove and venting system, it is good practice to burn the stove hot for 20 minutes or so every morning, especially after an overnight burn at a low rate of burn. This practice of a hot fire once a day will not only promote a clean stove and chimney, it will also help keep the glass clean for easy viewing of the fire within.

VI TROUBLESHOOTING

A. YOUR HEATING NEEDS

Virtually all woodstove operators experience basic common problems at one time or another. Most are correctable and generally require only a minor adjustment of the stove, installation, or operating technique. In cases where weather conditions dramatically affect stove performance, the problems are typically temporary and solve themselves once the weather changes.

If you question whether or not your stove is producing adequate heat, the best way to troubleshoot the problem is to monitor the temperature of the stack. A 400 degree F (200 degree C) stovepipe confirms the stove is supplying sufficient heat. Keep in mind that your house itself will regulate room/house temperatures. How well the walls, floors and ceilings are insulated, the number and size of glass windows, the tightness of outside doors, and the construction or style of your house (vaulted ceilings or other open spaces which collect large percentages of heat) all are determining factors of room temperature.

Your stove's performance is also dependant on its installation. One common cause of poor performance is an oversized chimney flue. Oversized chimney flues result in decreased pressure which prevents the smoke from rising out the chimney. Oversized flues are also more difficult to heat effectively, especially when burning a high efficiency stove. Cool flue temperatures inhibit the establishment of a strong draft (and encourage the accumulation of creosote). The lack of a strong draft will cause the fire to die down and may even force the smoke to pour into the room.

If your chimney is the proper size and a strong draft is not easily established, there is the possibility of the chimney being too cold. Again, hot chimneys promote a stronger draft.

Other draft guidelines are as follows:

AN "AIRTIGHT" HOUSE: If your home is super-insulated or especially well sealed, the (infiltration) air supply to the interior of the house may be inadequate. This phenomenon of air starvation within the building can be exacerbated if exhaust fans such as clothes dryers, bathroom fans or cookstove exhaust fans are in operation within the home. Outfitting your stove with the optional outside air supply adaptor connected to an air duct which leads to the outside of the building should correct this problem.

TALL TREES OR BUILDINGS in proximity to the top of the chimney can cause chronic or occasional down-drafts. When selecting a site for a new chimney, take care to consider the placement of other objects in the vicinity of the proposed chimney location.

WIND VELOCITY: Generally, the stronger and steadier a wind, the stronger (better) the draft. However, "gusty" wind conditions may cause erratic down-drafts.

BAROMETRIC PRESSURE: Chimney drafts are typically sluggish on balmy, wet or muggy days. This is a weather-related phenomenon which generally is self-correcting as the weather changes.

BRISKNESS OF FIRE: The hotter the fire in your stove, the hotter your chimney, and so the stronger the draft.

BREAKS IN THE VENTING SYSTEM: An unsealed clean-out door at the bottom of the chimney, leaky stovepipe joints, a poor stovepipe-to-thimble connection, or a leaky chimney may cause inadequate draft.

SEASONAL FACTORS: Early fall and late spring are generally difficult seasons in which to establish proper drafts. The colder the outside air (relative to room temperatures), the stronger the draft.

B. OPERATING THE STOVE

There are days when a draft is not easily established. As outlined above, seasonal factors or a cold chimney may be the cause. Try starting the fire by using small kindling and fuel to obtain a quick, hot fire. Tend the fire frequently with small fuel until the chimney is hot and the draft is well established.

C. TROUBLESHOOTING GUIDE

<u>PROBLEM</u>	<u>POSSIBLE CAUSE</u>	<u>SOLUTIONS</u>
STOVE SMOKES	Operating Technique:	Fully open the primary air control one minute before opening doors.
	Cold Chimney:	Preheat the chimney when first starting a fire.
	Blocked Chimney:	Examine the chimney and stovepipe for blockage or creosote accumulations.
	Oversized Chimney:	Reline the chimney to the appropriate diameter.

<u>PROBLEM</u>	<u>POSSIBLE CAUSE</u>	<u>SOLUTIONS</u>
STOVE SMOKES	Undersized Chimney:	Install a draft inducer or replace the chimney.
	Chimney Too Short:	Lengthen the chimney.
	Air Infiltration Into The Chimney:	Seal chimney connections and openings in clean-out doors.
	More Than One Appliance Connected to the Flue:	Disconnect all other appliances and seal openings.
BACK-PUFFING OR GAS EXPLOSIONS	Operating Technique:	Fully open the primary air control one minute before opening the door and keep it fully open for a few minutes after reloading.
	Extra Low Burn Rate:	Burn the stove at a higher burn rate.
	Chimney Downdraft:	Install a chimney cap.
	Excessive Ash Build-up:	Empty ash pan daily.
UNCONTROLLED OR SHORT BURN	Unsealed or Open Door:	Close the door tightly or replace the gaskets.
	Open Ash Grate	Slide ash grate to closed position.
	Excessive Draft:	Check the installation. Operate at LOW BURN.
	Deteriorated Cement Seals:	Reseal the stove with furnace cement.
	Extra Long Chimney:	Shorten the chimney.
	Oversized Chimney	Reline the chimney to the proper diameter.
	High Winds or Hilltop Location:	Install a chimney cap.
INSUFFICIENT HEAT	Poor Quality or Green Wood:	Use only air dried wood, preferably dried <u>at least</u> one year.
	Low Burn Rate:	Operate the stove at a higher burn rate.
	Air Insulated Chimney:	Replace with a pre-fabricated insulated chimney system or a properly sized masonry chimney.

<u>PROBLEM</u>	<u>POSSIBLE CAUSE</u>	<u>SOLUTIONS</u>
INSUFFICIENT HEAT	Exterior Chimney:	Insulate the chimney.
	Leaky Stovepipe or Chimney:	Check the installation.
	Too Much Heat Loss From House:	
BLISTERING OF ENAMEL CASTING	Leaky Stovepipe or Chimney:	Check the installation.
	Operating Technique:	Do not overfire the stove. Monitor stove temperatures.
	Excessive Draft:	Check the installation. Operate the stove at a LOW BURN range.

VII REPLACEMENT PARTS

<u>Item</u>	<u>Part Number</u>
Detachable Wooden Handle	94-58495
Top Casting	2600-003
Bottom Casting	2600-001
Back Panel	2600-002
Front Panel	2600-004
Ash Lip	2600-010
Ash Door	2600-011
Bottom Leg	2610-006
Side Leg	2610-009
Grate Plate	2610-008
Ash Pan Door Frame	2610-012
Air Control Handle	2610-XX
Primary Air Manifold	5600-033
Rear Baffle Support	5600-036
Air Tube Riser	5600-035
Stainless Steel Air Pipe	5600-034
Firebrick	3060
Top Stones (Left & Right)	1643-302
Top Stone (Center)	1643-303
Side Stones	1643-301
Ceramic Door Glass	3030-020
Front Door Latch	96-58621
Ash Door Latch	96-58621
Ash Pan	5600-024

VIII SPECIFICATIONS

SPECIFICATION

PHOENIX WOODSTOVE

MAXIMUM HEAT OUTPUT ¹	55,000 BTU/hour (Cordwood) 35,000 BTU/hour (EPA Method)
HEAT-LIFE ²	12 hours
SIZE OF HEATED AREA	Mid-size House
FIREBOX CAPACITY ³	2.3 CU FT ³ (0.227 m ³) 40 lbs of wood
MAXIMUM LOG LENGTH	19" (483 mm) Logs
MINIMUM RATE OF BURN	2.2 lbs per hour
HEIGHT	27-1/2" (698.5 mm)
WIDTH	28" (711 mm)
DEPTH	20" (508 mm)
FRONT DOOR SIZE	16-3/4 x 10-5/8" (425 x 270 mm)
STOVEPIPE SIZE	6" (152 mm) diameter
-METAL CHIMNEY	6" (152 mm) inside diameter
-MASONRY CHIMNEY	6" (152 mm) inside diameter (round flue) or 8" x 8" (203 x 203 mm) (square flue)
FLUE EXIT	Top or Rear Exit
ACTUAL WEIGHT	400 lbs
SHIPPING WEIGHT	435 lbs
CRATED DIMENSIONS	H- 34" (864 mm) W- 32" (813 mm) L- 29" (737 mm)
OPTIONAL EQUIPMENT	Rear Heat Shield Outside Air Kit
SOAPSTONE FINISH ⁴	Polished grey soapstone and Polished brown soapstone
CASTINGS FINISH	Painted black matte and Porcelain enamel colors

¹ Based on independent laboratory test results.

² Heat-Life is a trademark of NHC, Inc. and is defined as thermal capacitance or quantity of heat stored. Used here, it refers not just to burn time, but also to hours of usable heat obtained from a single load of fuel.

³ The amount and weight of wood contained per cubic foot of firebox volume can vary from 15 to 36 lbs. per cubic foot depending on type of wood, moisture content, packing density and other factors. As a constant for comparison and test purposes, we are assuming 20 lbs. of seasoned hardwood per cubic foot of firebox volume.

⁴ Polished grey soapstone varies from grey to grey-blue, according to natural composition. Polished brown soapstone varies from grey-brown to brown, according to natural composition.

STOVE DIMENSIONS:

