

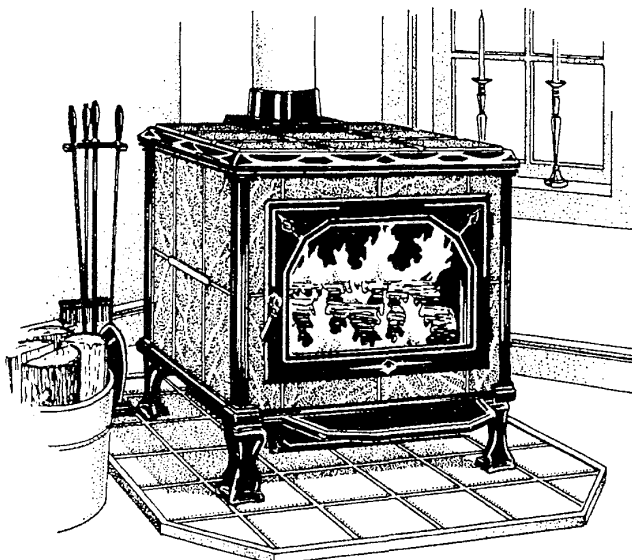

MANSFIELD OWNER'S MANUAL

INSTALLATION AND OPERATING INSTRUCTIONS



PLEASE READ THIS ENTIRE OWNER'S MANUAL BEFORE YOU INSTALL AND USE YOUR NEW MANSFIELD WOODSTOVE. FAILURE TO FOLLOW INSTRUCTIONS MAY RESULT IN PROPERTY DAMAGE, BODILY INJURY, OR DEATH.

SAFETY NOTICE

IF THIS STOVE IS NOT PROPERLY INSTALLED, A HOUSE FIRE MAY RESULT. FOR YOUR SAFETY, FOLLOW THE INSTALLATION DIRECTIONS. CONTACT LOCAL BUILDING OR FIRE OFFICIALS ABOUT RESTRICTIONS AND INSTALLATION INSPECTION IN YOUR AREA.

FOREWORD

Congratulations on your recent purchase of a HearthStone® Mansfield woodburning stove. The Mansfield is an EPA certified, non-catalytic woodburning stove. Your purchase insures you years of clean, comfortable heat with minimal maintenance. With the Mansfield you will receive the benefit of the most advanced technology in woodburning without the cost and maintenance requirements of a catalytic stove. In your Mansfield, modern technology blends with the unique beauty and heating qualities of soapstone, long known for its even heat production and long heat retaining ability. We trust that you will appreciate the quality of our handcrafted product.

Please read this manual in its entirety. Its purpose is to familiarize you with your stove's safe installation, proper break-in, operation and maintenance. It contains information that will be useful to you now and in years to come, so keep it handy and refer to it as needed.

The performance of your stove depends on many variables that make your installation unique. The sections on operating procedure and general information, therefore, can only serve as useful guidelines rather than hard and fast rules.

Should you have any questions, do not hesitate to contact your dealer for additional information.

You must return your warranty registration card to NHC, Inc. within 30 days of purchase in order to validate your warranty.

This stove is manufactured and warranted by:

NHC, Inc./HearthStone®
Stafford Ave.
PO Box 1069
Morrisville, VT. 05661

Once your warranty has been validated by returning your warranty card, contact your dealer for any necessary warranty service.

SAFETY NOTICE: IF THIS STOVE IS NOT PROPERLY INSTALLED, A HOUSE FIRE MAY RESULT. FOR YOUR SAFETY, FOLLOW THE INSTALLATION DIRECTIONS. CONTACT LOCAL BUILDING OR FIRE OFFICIALS ABOUT RESTRICTIONS AND INSTALLATION INSPECTION IN YOUR AREA.

SAVE THESE INSTRUCTIONS FOR FUTURE REFERENCE!

TABLE OF CONTENTS

I	INSTALLATION	3
	A. CLEARANCES TO COMBUSTIBLES	3
	1. USING SINGLE WALL STOVEPIPE WITHOUT HEAT SHIELD	4
	2. USING SINGLE WALL STOVEPIPE WITH REAR HEAT SHIELD	4
	3. USING CLOSE CLEARANCE STOVEPIPE WITH HEAT SHIELD	5
	B. CLEARANCES TO PROTECTED SURFACES	5
	C. FLOOR PROTECTOR: MATERIALS AND CLEARANCES	6
II	VENTING SYSTEM	6
	A. CHIMNEY CONNECTOR	7
	B. CONNECTION TO A PREFABRICATED METAL CHIMNEY	7
	C. CONNECTION TO A MASONRY CHIMNEY	9
	D. OUTSIDE AIR SUPPLY	10
III	OPERATING INSTRUCTIONS	10
	A. CONTROLS AND FEATURES	10
	B. BUILDING A FIRE	11
	1. BREAK-IN PROCEDURE	11
	2. BUILDING YOUR FIRST FIRE	11
	3. NORMAL OPERATION	12
	4. BURN RATE	12
	5. OVER-FIRE CAUTION	13
	6. REMOVAL AND DISPOSAL OF ASHES	13
IV	MAINTENANCE	14
	A. MONITORING STOVE TEMPERATURES	14
	B. CREOSOTE FORMATION AND NEED FOR REMOVAL	14
	C. GASKETS	14
	D. GLASS	15
	E. STONE	16
	F. CAST IRON	16
V	OPERATION GUIDELINES	16
	A. SAFETY GUIDELINES	16
	B. EMERGENCY PROCEDURES	18
	C. FIREWOOD	18
	D. OPERATING YOUR STOVE EFFICIENTLY	19
VI	TROUBLESHOOTING	20
	A. YOUR HEATING NEEDS	20
	B. OPERATING THE STOVE	21
	C. TROUBLESHOOTING GUIDE	21
VII	REPLACEMENT PARTS	23
VIII	SPECIFICATIONS	24
IX	SAFETY LABEL	25

I INSTALLATION

SAFETY NOTICE: IF THIS STOVE IS NOT PROPERLY INSTALLED, A HOUSE FIRE MAY RESULT. FOR YOUR SAFETY, FOLLOW THE INSTALLATION DIRECTIONS. CONTACT LOCAL BUILDING OR FIRE OFFICIALS ABOUT RESTRICTIONS AND INSTALLATION INSPECTION IN YOUR AREA.

Read these instructions completely before installing your stove. Avoid the possibility of a fire by installing this stove in accordance with these instructions as well as national, state, and local building codes. Be sure to maintain the designated stovepipe and stove clearances to walls, ceilings, hearth, and other combustible surfaces.

When locating your stove, consider safety, convenience, traffic flow, and the fact that the stove will need a chimney and chimney connector. Your stove should be located away from doors and hallways in an open area to allow for necessary clearances. Review the clearance illustrations for proper measurements from combustibles.

Keep furniture, drapes, curtains, wood, paper, and other combustibles far away from the stove. Never install the stove in locations where gasoline, kerosene, charcoal lighter, or any other flammable liquids are used or stored.

The soapstone walls of a HearthStone soapstone stove produce an even, radiant heat. Locate the stove centrally in your living area to allow the heat to travel naturally to distant rooms. It is not recommended that you locate your stove in the basement. The amount of radiant energy required to heat concrete basement walls is so great that most of the useable heat is absorbed by them and lost.

A. CLEARANCES TO COMBUSTIBLES

DO NOT CONNECT THIS UNIT TO A CHIMNEY FLUE SERVING ANOTHER APPLIANCE

If you use a rear heat shield to obtain reduced clearances, you must use the rear heat shield manufactured by NHC, Inc. available through your local dealer. Clearances cannot be reduced unless the rear heat shield is used with close clearance connector pipe.

Single wall stovepipe is 24 MSG or 25 MSG blued steel connector pipe.

Close clearance connector pipe is DVL-Air insulated connector pipe which must be used with a listed factory-built Class "A" chimney or a masonry chimney. When used in a mobile home, a spark arrester is required.

1. USING SINGLE WALL STOVEPIPE WITHOUT HEAT SHIELD

◆ RESIDENTIAL AND MOBILE HOME INSTALLATIONS

◆ Maintain 18" min. clearance between horizontal chimney connector and ceiling.

PARALLEL INSTALLATION:

E: Sidewall to Stove

USA: 25" (635 mm)

CAN: 33" (838 mm)

A: Backwall to Stove

USA: 23" (584 mm)

CAN: 27" (685 mm)

B: Sidewall to Pipe

USA: 34" (864 mm)

CAN: 33" (838 mm)

D: Backwall to Pipe

USA: 24" (609 mm)

CAN: 28" (711 mm)

CORNER INSTALLATION:

C: Wall to Stove Corner

USA: 20" (508 mm)

CAN: 20" (508 mm)

F: Wall to Pipe

USA: 29" (736 mm)

CAN: 29" (736 mm)

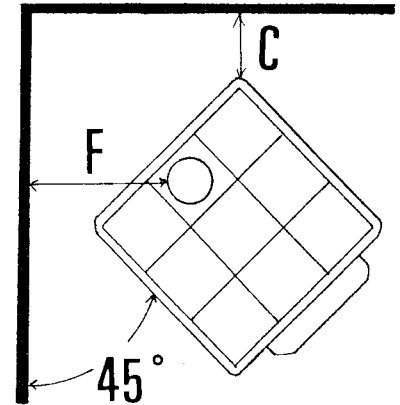
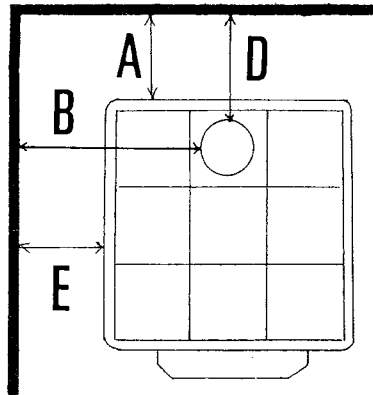

2. USING SINGLE WALL STOVEPIPE WITH REAR HEAT SHIELD

◆ RESIDENTIAL INSTALLATIONS

PARALLEL INSTALLATION:

E: Sidewall to Stove

USA: 25" (635 mm)

CAN: 24" (609 mm)

A: Backwall to Stove

USA: 11" (279 mm)

CAN: 15" (381 mm)

B: Sidewall to Pipe

USA: 34" (864 mm)

CAN: 33" (838 mm)

D: Backwall to Pipe

USA: 12" (305 mm)

CAN: 16" (406 mm)

CORNER INSTALLATION:

C: Wall to Stove Corner

USA: 15" (381 mm)

CAN: 15" (381 mm)

F: Wall to Pipe

USA: 24" (609 mm)

CAN: 24" (609 mm)

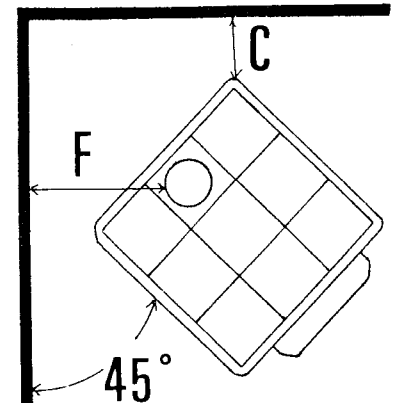
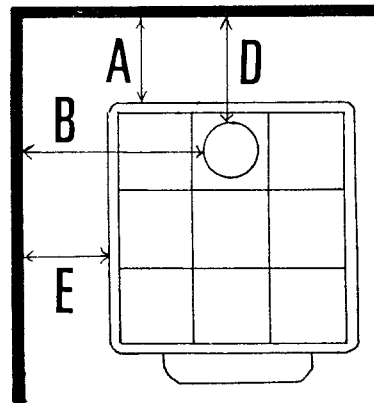

3. USING CLOSE CLEARANCE STOVEPIPE WITH HEAT SHIELD ◆ RESIDENTIAL AND MOBILE HOME INSTALLATIONS

PARALLEL INSTALLATION:

E: Sidewall to Stove

USA: 25" (635 mm)

CAN: 24" (609 mm)

A: Backwall to Stove

USA: 11" (279 mm)

CAN: 15" (381 mm)

B: Sidewall to Pipe

USA: 34" (864 mm)

CAN: 33" (838 mm)

D: Backwall to Pipe

USA: 12" (305 mm)

CAN: 16" (406 mm)

CORNER INSTALLATION:

C: Wall to Stove Corner

USA: 15" (381 mm)

CAN: 15" (381 mm)

F: Wall to Pipe

USA: 24" (609 mm)

CAN: 24" (609 mm)

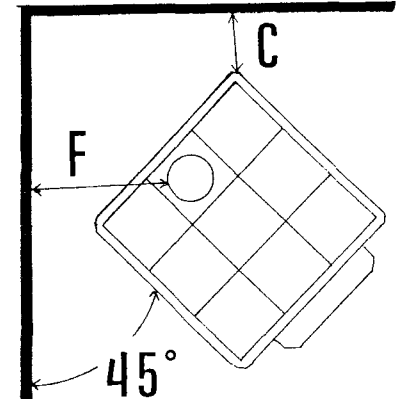
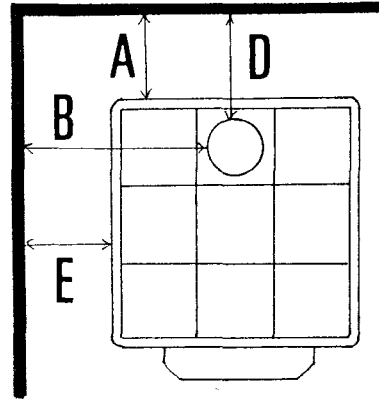

B. CLEARANCES TO PROTECTED SURFACES

Clearances to combustible surfaces can be reduced by using any NFPA approved wall protection system.

REFER TO NFPA 211 FOR SPECIFIC AND COMPLETE DETAILS:

National Fire Protection Agency

Batterymarch Park

Quincy, MA 02269

1-800-344-3555

1-617-770-3000

It is very important to follow minimum clearances for chimney connectors to combustibles such as walls and ceilings when installing the stove near non-combustible surfaces. These chimney connector clearances are outlined below in the section titled "CHIMNEY CONNECTOR".

C. FLOOR PROTECTOR: MATERIALS AND CLEARANCES

The stove must be placed on a floor protector if the floor is wood or other combustible flooring. If carpeting is present, it must be removed. The floor protector must not be placed on carpet.

An acceptable floor protector is a 3/8" (10 mm) minimum thickness non-combustible or listed floor protector with an "R" factor of 1.0.

The floor protector must have minimum dimensions of 41" x 46" (1041 X 1168 mm) and must extend beyond the body of the stove at minimum as follows:

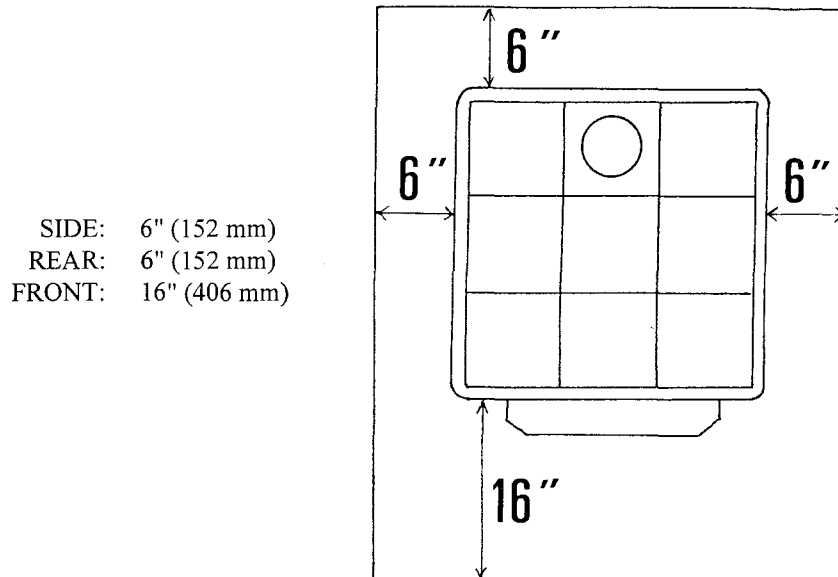

II VENTING SYSTEM

The complete venting system consists of several components. These components are absolutely necessary to provide safe clearances to combustible wall and ceiling materials. To protect against the possibility of a house fire, the venting system must be properly installed and constantly maintained. Replace rusted, cracked, or broken components.

The *chimney connector* is the stovepipe that is installed into the flue collar on the woodstove.

A *thimble* is a manufactured or site-constructed device installed in combustible walls through which the chimney connector passes to the chimney. It is intended to keep walls from igniting and must be used when a connection is made through a combustible wall to the chimney.

A *wall pass-through* or chimney support package must be used when a connection is made through a wall or ceiling to a prefabricated chimney.

This stove may be connected to a lined *masonry chimney* or an approved high temperature *prefabricated residential* type building heating appliance chimney. Do *not* connect this stove to a chimney serving another appliance as doing so will affect the safe operation of both appliances. Do not connect this appliance to any chimney or ducting of an air distribution system.

A. CHIMNEY CONNECTOR

The chimney connector stovepipe must be 6" (152 mm) diameter, 24 MSG or 25 MSG blued steel connector pipe. Do not use aluminum or galvanized steel pipe as they cannot properly withstand the extreme temperatures of a wood fire.

Do not use stovepipe as a chimney. You must connect your stove to a chimney comparable to those recommended in this manual. Stovepipe is to be used only to connect the stove to a proper chimney.

Stovepipe sections must be attached to the stove and to each other with the crimped end toward the stove. In the event of a creosote buildup this allows the creosote to run into the stove and not the outside of the stovepipe and onto the stove.

All joints, including the connection when the stovepipe attaches to the stove's flue collar, must be secured with three sheet metal screws. Failure to properly secure the connections may result in joint failures with the stovepipe vibrating apart in the event of a creosote chimney fire. Holes pre-drilled in the flue collar accept 1/8" X 1/2" (3 mm x 13 mm) sheet metal screws.

Additional stovepipe accessories such as draw-bands, slip-joints and clean-out tees greatly simplify the installation of stovepipe from the stove to the chimney, making inspection easier. These accessories also allow for easy dismantling of the stovepipe, without having to moving the stove, for periodic inspection of the stovepipe connector and chimney.

The longer the stovepipe length and/or the larger the number of elbows, the greater the chance of draft resistance and the greater the chance for creosote accumulation. In the past installers strove for long runs of pipe to increase heat dispersal. Because of the Mansfield's high efficiency, however, this is unnecessary. The stovepipe should be as short and straight as possible. The stove should be installed as close as practical (maintaining all proper clearances) to the chimney. Horizontal runs of stovepipe should always rise away from the stove a minimum of 1/4" per foot (21mm/m).

The Mansfield does not generally require a stovepipe damper. However, some installations may have variables, most frequently a tall chimney, that may create a higher than normal draft which may benefit from a stovepipe damper. The Mansfield requires a draft between 0.6 wc and 0.1 wc. Any draft above 0.1 wc requires a stovepipe damper.

The National Fire Protection Agency (NFPA) has recommended, minimum clearances for chimney connectors to combustibles such as walls and ceilings. Once the stove is installed at safe distances from combustible surfaces, it is important to maintain proper connector clearances for the remainder of the installation. For example, a horizontal run of stovepipe must not exceed NFPA recommended clearances from the ceiling (18").

B. CONNECTION TO A PREFABRICATED METAL CHIMNEY

When a prefabricated metal chimney is used, the manufacturer's installation instructions must be followed precisely. Only Class A 103 H.T., solid insulation type prefabricated metal chimneys may be used with this stove.

When installing a prefabricated chimney you must also purchase (from the same manufacturer) and install the ceiling support package or wall pass-through and "T" section package, fire-stops (when needed), insulation shield, roof flashing, chimney cap, etc. Follow the instructions provided by the manufacturer and maintain all proper clearances to the structure as recommended by the manufacturer.

There are basically two methods of prefabricated metal chimney installation:

- 1) An interior installation where the chimney passes inside the residence through the ceiling and roof.
- 2) An exterior installation where the chimney passes through the wall behind the stove then up the outside of the residence.

In all cases an interior chimney is recommended if possible. An interior chimney heats up more quickly and retains its heat, which both promotes a better draft and discourages the formation of creosote. An exterior chimney does not benefit from the warmth of being surrounded by the building, so it typically operates at lower flue temperatures than an interior chimney. An exterior chimney typically does not have as strong a draft as an interior chimney and may experience increased creosote accumulation.

Height requirements for a prefabricated metal chimney are the same as for a masonry chimney: At least 3 feet (0.91 m) higher than the highest part of the roof opening through which it passes and at least 2 feet (0.61 m) higher than any part of the roof within 10 feet (3 meters) as measured horizontally from the top of the chimney. This stove requires a minimum chimney height of 13 feet (3.9 m). The maximum allowable chimney height is 30 feet (9m).

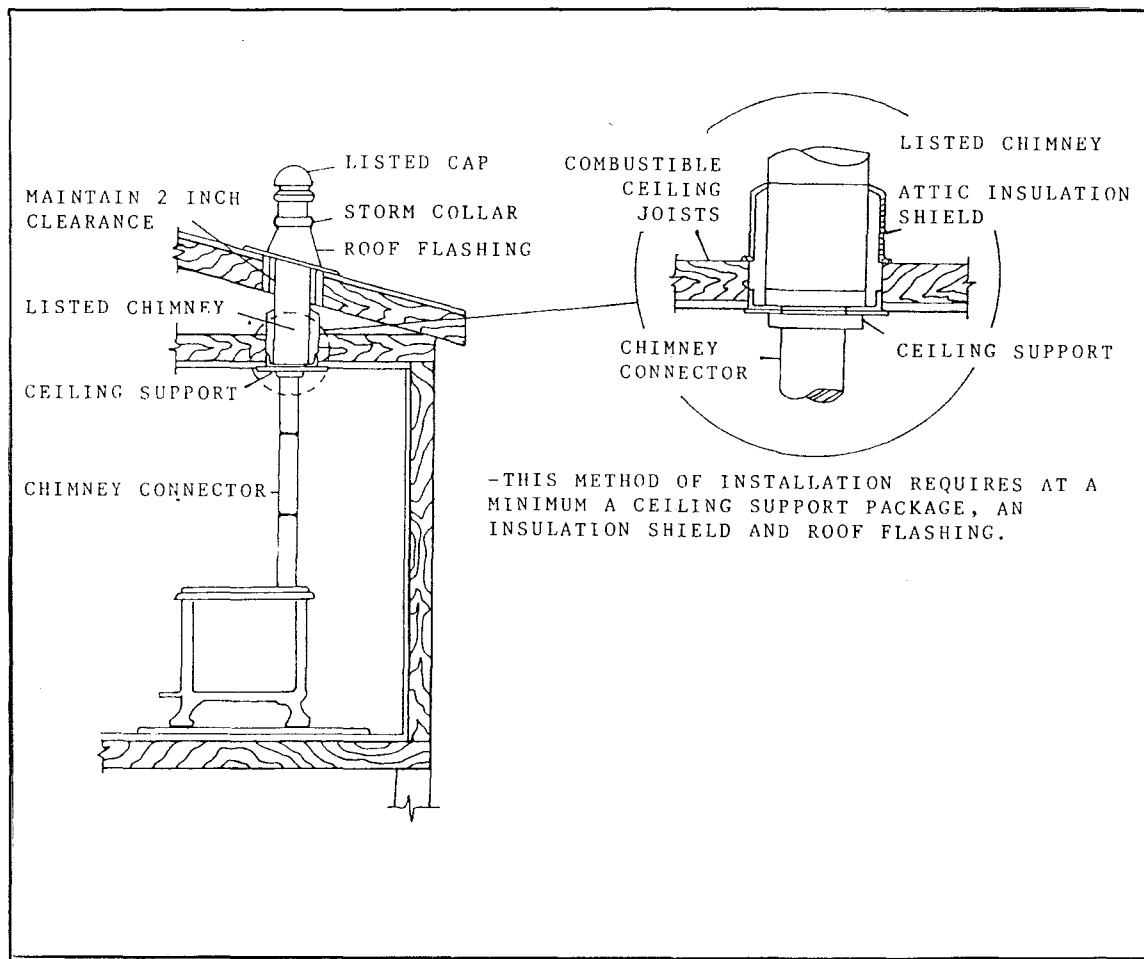

TYPICAL PREFABRICATED CHIMNEY INSIDE THE HOUSE

C. CONNECTION TO A MASONRY CHIMNEY

There are two primary elements to consider when connecting a stove to a masonry chimney: the chimney itself and the thimble where the stovepipe connects to the chimney.

Prior to connecting a stove to a masonry chimney, the chimney should be examined for cracks, loose mortar, and other signs of deterioration and blockage. The stove should not be installed until it is determined that the chimney is safe for use. If repairs to the chimney are required, they should be completed before the stove is put into service.

An oversized flue will contribute to the accumulation of creosote. Therefore, the size of the flue should be checked to determine that it is not too large for this stove. The Mansfield requires a flue no larger than 6" (152 mm) inside diameter or 8" x 8" (203 mm x 203 mm).

The following is a checklist of minimum requirements for masonry chimneys:

- ◆ Chimney wall construction:
 - Brick or modular block at least 4" (102 mm) thick.
 - A rubble or stone wall at least 12" (305 mm) thick.
- ◆ Must have a fire clay flue liner:
 - Minimum thickness of 5/8" (16 mm).
 - Installed with refractory mortar.
 - At least 1" (25 mm) air space.
 - An equivalent flue liner must be a listed chimney liner system or other approved material.
- ◆ Interior chimney requirements:
 - At least 2" (51 mm) clearance to combustible structure
 - Fire stops must be installed at the spaces where the chimney passes through floors and/or ceiling.
 - Insulation must be 2" (51 mm) from the chimney.
- ◆ Exterior chimney requirements:
 - At least 1" (25 mm) clearance to combustible structure.
- ◆ Chimney height requirements:
 - At least 3 feet (0.9 m) higher than the highest part of the roof opening through which it passes and at least 2 feet (0.6 m) higher than any part of the roof within 10 feet (3 m) measured horizontally from the top of the chimney. This stove requires a minimum chimney height of 13 feet (4 m). The maximum allowable chimney height is 30 feet (9m).

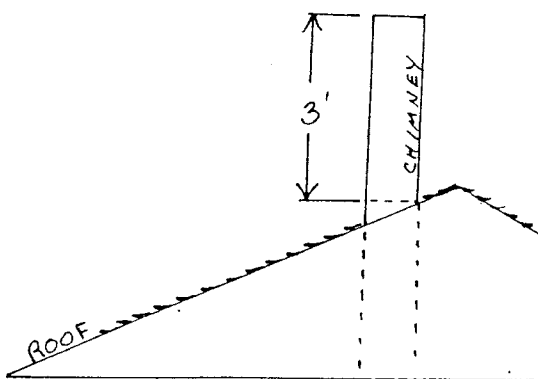

AT LEAST THREE FEET HIGHER THAN HIGHEST PART OF ROOF OPENING THROUGH WHICH IT PASSES

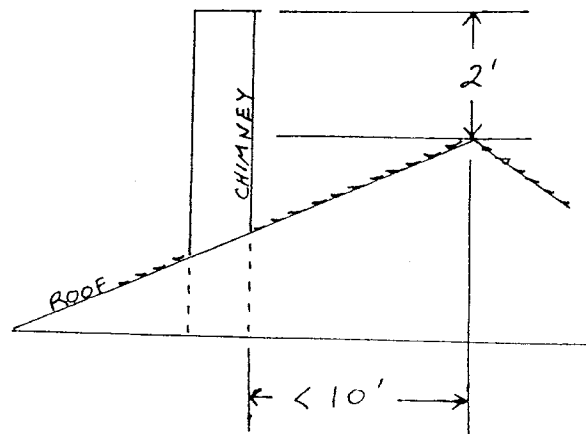

AND AT LEAST TWO FEET HIGHER THAN ANY PART OF THE ROOF WITHIN TEN FEET

D. OUTSIDE AIR SUPPLY

An outside air source may be connected directly to this stove using an optional outside air kit. The advantage of providing outside air directly to the stove is that the air used by the stove for combustion is taken from outside of the residence rather than from within the room where the stove is located. With outside air supplied directly to the stove, drafts within the room and air infiltration within the building are reduced. Use of the outside air kit may also improve stove performance in a particularly air tight house.

The outside air kit for this stove allows for the direct connection of the stove's air intake to a minimum 3" (76 mm) diameter duct (supplied by others) which leads to the outside of the house. When considering placement of the duct from the outside of the house to the hearth keep in mind the need to avoid structural members of the house and that the duct should terminate at the lower, center portion of the hearth. Connection of the duct to the stove is made on the lower, center section of the stove's ash pan box. The termination of the duct on the outside wall of the stove should be located in such a manner so as to preclude the possibility of obstruction by snow, leaves or other material and should be screened against animals and insects.

REAR VIEW: OUTSIDE AIR KIT

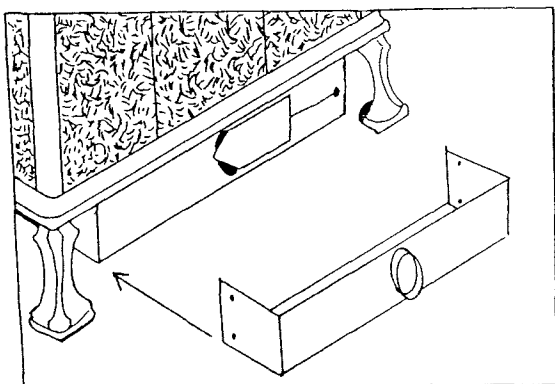

III OPERATING INSTRUCTIONS

A. CONTROLS AND FEATURES

You should become familiar with the location and operation of your stove's controls and features. Do not modify these features in any way.

REMOVABLE WOODEN HANDLE: A single detachable handle is provided to operate both the front loading door and the ash pan door. It is designed as a detachable handle to prevent the operator from burning their hand when opening the door on a hot stove.

PRIMARY AIR CONTROL: Located on the lower left side of the stove, under the removable ash lip, the primary air control regulates the amount of air entering the firebox. Generally speaking, the more air allowed into the firebox, the faster and hotter the rate of burn.

ASH PAN: The ash pan and ash pan access door are located under the ash lip. The firebox should be cleared of ashes daily by sliding the ash grate sideways, sifting the ashes across the grate into the ash pan, then returning the grate to its closed position. Do not operate the stove with the grate open. This could damage the stove. The ash pan is easy to remove and has a handle for convenient disposal of ashes.

B BUILDING A FIRE

CAUTION: DO NOT USE CHEMICALS OR FLUIDS TO START A FIRE. DO NOT BURN GARBAGE OR FLAMMABLE FLUIDS SUCH AS GASOLINE, NAPHTHA, KEROSENE, CHARCOAL LIGHTER FLUID OR ENGINE OIL.

1. BREAK-IN PROCEDURE

It is imperative that your stove be "broken in" slowly. Cast iron must be "seasoned"; over-firing a new stove may cause castings to crack or may damage other stove parts. Moisture in the soapstone must be driven out slowly to minimize the "shock" to the stone of its first exposure to high firebox temperatures. Also, the asbestos-free furnace cement must be cured slowly to insure adequate sealing and bonding. The first two or three fires in your new stove will also cause the high temperature paint to give off a strong odor and some smoke. The odor and smoke will end once the stove is "cured".

The bottom layer of soapstone in your firebox is intended to prevent thermal stress and should remain in place in the firebox at all times.

2. BUILDING YOUR FIRST FIRE

1. Open the door and place five or six double sheets of tightly twisted newspaper in the center of the firebox. Arrange kindling in a crisscross pattern over the newspaper. Kindling should be approximately ten pieces, 1/2" (13 mm) in diameter and 10" to 18" (254 mm to 457 mm) long.
2. Fully open the primary air control by rotating the control handle fully counterclockwise.
3. Light the paper under the kindling. Leave the front door slightly ajar momentarily until the kindling has started to burn and draft begins to pull.
4. Close the door and allow the fire to burn. Keep the door and ash drawer closed while the stove is in use. Make sure the grate is in the closed position.
5. KEEP A WATCHFUL EYE ON YOUR STOVE to maintain a steady, low-heat fire. Your first and subsequent break-in fires should make the stove warm but not hot to the touch. At most, a few small chunks of wood should be added to the fire to reach safe break-in temperatures.
6. Once the stove is warm but not hot to the touch close the primary air control and allow the fire to die out completely.
7. Let the stove return to room temperature.

Your first three break-in fires should be built and maintained as outlined above. Your patience will be rewarded by a properly seasoned stove.

NOTE: Because of the cool flue gas temperatures present during the break-in procedure, creosote may build up quickly. We recommend a visual inspection (and cleaning if necessary) of your stovepipe and chimney once the break-in procedure is completed.

3. NORMAL OPERATION

If your stove is not used continuously or has not been used in quite some time, follow the break-in procedure at least once to minimize the stress of a hot fire on a cold stove before proceeding with normal operation. We recommend one break-in fire at the start of each heating season. Prior to loading the stove, make sure the ash grate and ash pan door are closed. If they are left open, the stove will over-fire and be damaged.

To build a fire for everyday use:

1. Open the door and place five or six double sheets of tightly twisted newspaper in the center of the firebox. Arrange kindling in a crisscross pattern over the newspaper. Kindling should be approximately ten pieces, 1/2" (13 mm) in diameter and 10" to 18" (254 to 457 mm) long.
2. Fully open the primary air control by rotating the control handle fully counterclockwise.
3. Light the paper under the kindling. Leave the front door slightly ajar momentarily until the kindling has started to burn and draft begins to pull.
4. Close the door and allow the fire to burn.
5. Once the kindling is burning, open the door and add logs, small at first, to build the fire up. Make sure to keep the logs away from the glass in front in order for the air-wash system to work properly. Otherwise, keep the door and ash drawer closed while the stove is in use.
6. Once the fire is burning well, use the primary air control to regulate the desired rate of burn. Turn the primary air control counterclockwise for a high rate of burn or clockwise for a low rate of burn.

Note: Whenever opening the door to reload or re-arrange logs, it is advisable to open the door just a crack, pause for a moment, then open the door completely. This procedure will allow the firebox to clear of smoke before the door is opened fully. Also, reloading on a bed of hot, red coals reduces smoking time and will bring fresh fuel up to a high temperature rapidly.

4. BURN RATE

HIGH BURN: Fully load the firebox with wood on a bed of hot coals or on an actively flaming fire and fully open the primary air control. A high burn rate is recommended once or twice a day to fully heat the stovepipe and chimney which will help minimize creosote accumulation. The temperature on the top center stones will be 500-600° F (260-315°C).

MEDIUM BURN: Set the primary air control to a mid-range setting appropriate for the heating needs of the area being heated. A medium burn rate should be the typical setting and is preferable if the stove is to be left unattended. The temperature on the top center stones will be 400-500° F (200-260°C).

LOW BURN: Close the primary air control for a low burn rate. A low burn rate over extended periods of time is not advisable as it may promote the accumulation of creosote. The venting system should be inspected frequently if low burn rates are maintained consistently. The temperature on the top center stones will be less than 400° F (200°C).

5. OVER-FIRE CAUTION

Over-firing means the stove is operating at temperatures above the recommended temperatures outlined previously on page 12. Over-firing should be carefully avoided since it will cause damage to the stove. Symptoms of over-firing include short burn times, a roaring sound in the stove or stovepipe, and discoloration of the stovepipe.

Over-firing can be caused by excessive draft, inappropriate fuel, and operator error. Correct an over-fire situation as follows:

EXCESSIVE DRAFT: Contact your dealer to have a draft reading taken. Any draft in excess of 0.1 w.c. requires a damper in the stovepipe. Some installations may require more than one damper.

INAPPROPRIATE FUEL: Do not burn coal, kiln dried lumber, wax logs or anything other than natural cordwood.

OPERATOR ERROR: Make sure all the gaskets are in good condition. Replace worn out or compressed gaskets. Do not burn the stove with the front door, ash door, or ash grate in the open position.

Monitoring the temperature is the best way to determine that the stove is over-firing. If you suspect that your stove is over-firing, contact your dealer immediately. **Damage done by over-firing is not covered by your warranty.** Results of over-firing can include: warped or burned out internal parts, cracked stones, discolored or warped external parts, and damaged enamel.

NOTE: ANY SYMPTOMS OF OVER-FIRING WILL VOID YOUR WARRANTY!!

6. REMOVAL AND DISPOSAL OF ASHES

To remove ashes from the firebox, slide the ash grate sideways so that the slots in the grate line up with the slots in the bottom and sift the ashes across the ash grate using a poker or other suitable implement. Open the ash pan door with the removable wooden handle. Before removing the ash pan, push it (hard) into the stove to force it upward which kicks the ashes further into the pan. Be sure to return the ash grate to its closed position and close the ash door tightly. Alternately, the ashes can be removed with a shovel through the front door.

Ashes should be dumped from the ash drawer into a metal container with a tight fitting lid. Do not place any other items or trash into the metal container. Replace the lid onto the container and allow the ashes to cool. Do not place the ash disposal container on a combustible surface or vinyl flooring as the container will be hot!

Pending disposal, place the closed ash container on a noncombustible floor or on the ground, well away from all combustible materials. Ashes should be retained in the closed container until all cinders have thoroughly cooled.

Ashes should NEVER be placed in wooden or plastic containers, or in paper or plastic bags, no matter how long the fire has been out. Coals within a bed of ashes can remain hot for several days once removed from the firebox.

IV MAINTENANCE

A. MONITORING STOVE TEMPERATURES

Monitor the stove temperatures with a stove thermometer placed on the top center stone of the stove. The thermometer could read as high as 600°F (427°C) on high burn and 300-400 degrees F (149°-204°C) on low burn.

Do not over-fire the stove (see page 13).

B. CREOSOTE FORMATION AND NEED FOR REMOVAL

When wood is burned, it produces tar, water vapor, and other organic vapors. These vapors condense and form creosote on the walls of chimneys which are cool due to newly started fires, low burn rates or poor chimney design. If ignited, this creosote residue makes an extremely hot fire which may damage the chimney or even destroy the house.

To prevent the buildup of creosote:

1. Burn the stove with the primary air control fully open for 30 minutes daily to burn out creosote deposits from within the stove and the venting system.
2. After reloading with wood, burn the stove with the primary air control fully open for 20 to 30 minutes. This manner of operation ensures early engagement of the secondary combustion system which, when engaged, minimizes creosote buildup in the chimney.

The stovepipe connector and chimney should be inspected at least twice monthly during the heating season to determine if a creosote build-up has occurred. If a creosote residue greater than 1/4" (6 mm) has accumulated, it should be removed to reduce the risk of a chimney fire.

The venting system must be inspected at the stove connection *and* at the chimney top. Cooler surfaces tend to build creosote deposits quicker, so it is important to check the chimney at the top (where it is coolest) as well as from the bottom near the stove.

Accumulated creosote should be removed with a cleaning brush specifically designed for the type of chimney in use. A certified chimney sweep should be used to perform this service. Contact your dealer for the name of a certified chimney sweep in your area (your dealer may be a certified sweep!).

It is also recommended that before each heating season the entire system be professionally inspected, cleaned and repaired, if necessary.

C. GASKETS

Gasket material should normally be replaced every two to three seasons, depending on stove use. If the door seal is loose, a new gasket will assure a tight seal and improved stove performance. Contact your dealer for a gasket kit which includes instructions and gaskets for your stove.

The procedure for replacing gaskets on the glass is reviewed in Section D, GLASS.

To replace door gaskets, first remove the old gaskets with a utility or putty knife. Clean all gasket channels with a wire brush. Apply gasket cement to the channels and push the new gasket into place without stretching the gasket material. The door should be shut immediately to fully press the gasket into place assure a

positive seal.

We require the use of the following gaskets:

- GLASS: 60" (152 mm) Length, 3/4" (19 mm) Wide, Adhesive Backed Black Tape
- DOOR: 60" (152 mm) Length, 3/8" (9 mm) Diameter, Low Density Black Tube
- ASH DOOR: 32" (81mm) Length, 1/4" (6 mm) Diameter, Low Density, Black Tube

D. GLASS

Do not operate the stove with a broken door glass. Do not abuse the front door by striking or slamming.

When necessary, the glass can be cleaned with commercial stove glass cleaners which are available from your local dealer. Never attempt to clean the glass while the fire is burning or the glass is hot. Most deposits can be cleaned by following the instructions provided with the cleaner. To clean heavier deposits, open the door and lift it straight up and off the stove (take care to save hinge pins and washers for reuse). Lay the door face down on a work bench or table. Apply the cleaner to the glass and allow it to set for a few minutes. By laying the door flat, it will allow the cleaner to penetrate rather than running off the surface of the glass. Wipe the cleaner off with a soft cloth. **Important:** scratching or etching the glass will weaken the integrity of the glass. **Do not** use a razor blade, steel wool, or any other abrasive material to clean the glass.

The front door glass is a ceramic, shock-resistant glass, made specifically for use in woodstoves. **Do not use any replacement glass other than the ceramic glass manufactured and supplied for use in this woodstove.** Replacement glass is available through your local dealer.

The door glass should be replaced immediately if broken. Contact your local dealer for replacement glass which is accompanied with instructions and everything needed for the repair. If you replace the glass yourself, wear work gloves and safety glasses.

The procedure for glass and glass gasket replacement is as follows:

1. Remove the door by lifting it straight up off the hinges with the hinge pins remaining in the door.
2. Place the door face down on a flat, smooth surface.
3. Apply penetrating oil to the screws in the retention frame. Remove the window frame screws to separate the window frame from the door.
4. Carefully lift the damaged glass from the door and discard.
5. Peel the paper backing from the tape gasket. Apply the new gasket to the new glass as illustrated.
6. Place the gasketed glass onto the door.
7. Screw the window frame back on the door.
8. Install the door.

GASKETING THE GLASS: ↘

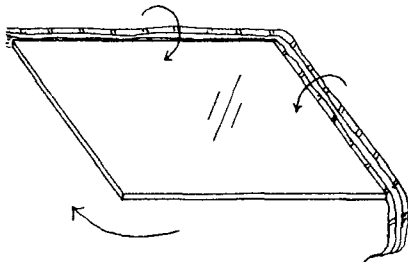

CROSS SECTION: ↘

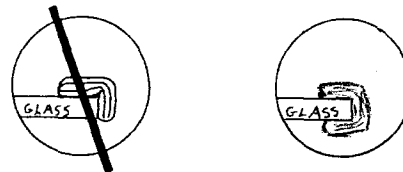

E. STONE

Occasional cleaning is all that should be necessary to maintain the natural beauty of your stove's polished soapstone finish. Clean the soapstone with water, any non-abrasive cleaner and a soft cloth. Wipe dust from the stone with a clean cloth. Do not use chemical agents to wash the stone; do not use waxes or any polishing agents on the stone.

Care must be taken not to scratch or chip the stone. Do not set items which can scratch or chip the stone (or enamel finish) on top of your stove.

Often, with use and over time, subtle earth tones of brown, red, and yellow appear on the soapstone. This is a natural reaction in the soapstone. With normal use, hairline or surface cracks may appear in the stone. Such cracks do not affect the integrity or operation of the stove and do not require replacement.

F. CAST IRON

Exterior cast iron parts are either painted with black, high-temperature stove paint or porcelainized with an enamel finish in various colors.

Use black, high-temperature stove paint to touch up and maintain the original appearance of painted cast iron. Use a damp sponge to wipe clean. Dry the cast iron thoroughly to prevent rusting.

Enamel castings can be cleaned with a standard glass cleaner. With time and use, a very fine, subtle network of crazed lines may appear seemingly beneath the surface of the enamel. Crazing is a natural predictable process and does not represent a flaw.

V OPERATION GUIDELINES

A. SAFETY GUIDELINES

DO THE FOLLOWING:

- Read and understand this Owner's Manual thoroughly before installing this stove.
- Install the stove according to the manufacturer's recommendations.
- Install this stove in accordance with all applicable codes.
- Install this appliance with the proper sized chimney.
- Follow recommended break-in procedure as outlined in this manual.
- Burn natural wood only. Higher efficiencies and lower emissions result when burning air dried, seasoned wood, as compared to green or freshly cut wood.
- Use caution when loading firewood into a hot stove.
- Keep the front door closed at all times except when loading wood.
- Warn children and others unfamiliar with woodstoves of the danger of touching hot, radiating surfaces. Hearth and stove guards may be obtained through your local dealer.
- Inspect the stove pipe, chimney connector and chimney frequently, as recommended.
- Be sure the removable ash lip is in place while burning the stove as it was certified for

operation. Otherwise, the hearth may exceed safe temperatures.

DO NOT DO THE FOLLOWING:

- Modify this product in any way, including the primary air control system.
- Expect the stove to heat more than 50% of the recommended volume if installed in a basement or in any area with a large portion of uninsulated masonry walls.
- Burn kiln dried wood, painted or treated wood, solvents, trash, plywood, colored or glossy paper, artificial logs, cardboard, coal, garbage or driftwood.
- Burn coal in this stove.
- Use gasoline, kerosene or other liquid fuels to start or invigorate the fire.
- Burn the stove with the ash door open or the grate in the open position.
- Use a wood grate or other device to elevate the fire.
- Allow logs to rest against or otherwise come in contact with the glass when the door is closed.
- Slam the door.
- Let the stove burn without the removable ash lip in place while burning the stove as it was certified for operation. Otherwise, the hearth may exceed safe temperatures.

OTHER SAFETY GUIDELINES

1. Always keep all combustible items (furniture, drapes, clothing, etc.) a minimum of 36" (0.92 m) from the stove. (Clearances pages 3 - 6)
2. Do not over-fire your stove. (Over-fire Caution page - 13)
3. Install a smoke alarm.
4. Keep a fire extinguisher handy. We recommend the type rated "A B C."
5. Dispose of ashes properly. (Removal And Disposal Of Ashes page - 13.)
6. **NEVER** use gasoline type fuel, kerosene, charcoal lighter fluid or similar liquids or solid fire starters to start or invigorate a fire. Keep all such materials away from the stove.
7. Keep children and pets away from the stove.
8. **NEVER** put articles of clothing or candles on a hot stove.
9. Do not connect the stove to a flue that is serving another appliance. (Venting System page - 6.)
10. Clean your system as needed. (Creosote Formation And The Need For Removal page -14.)

PERIODIC CHECKLIST

EVERY WEEK

- Empty ashes from the firebox and ash pan.

EVERY TWO WEEKS

- Visually inspect chimney connector and chimney for creosote; clean accordingly.

EVERY EIGHT WEEKS

-Check door seals using the "dollar bill test." When the fire is out and the stove cool, shut the door on a dollar bill. If the bill pulls out without any resistance, the door isn't sealed properly. Change the door gasket.

AT SEASON'S END

- Dismantle chimney connector and clean thoroughly; replace any pieces that show signs of rust or deterioration.
- Inspect and, if necessary, clean your chimney.
- Thoroughly clean out the inside of the stove.
- Inspect all door gasket material and replace if worn, frayed, cracked or extremely hard.

B. EMERGENCY PROCEDURES

In the event of a stovepipe or chimney fire follow these instructions:

1. Close the primary air control.
2. Close the stovepipe damper (if present).
3. Keep the stove door shut.
4. Call the fire department.
5. Keep an eye on the stove, stovepipe, and chimney.

Do NOT attempt to extinguish a stovepipe or chimney fire by throwing water onto the stove, stovepipe or chimney. The extremely high temperatures associated with such fires can cause instantaneous steam and serious bodily harm.

Once the chimney fire has expired, leave the primary air control closed and let the fire in the stove die out completely. The stove should not be fired again until the stove, stovepipe, and chimney are all thoroughly inspected for any sign of damage. Damage must be corrected before resuming use of your stove.

C. FIREWOOD

The quality of your firewood is an important variable which affects heat output, duration of burn and stove performance. Softwoods generally burn hotter and faster, while hardwoods burn longer and produce more coals.

The density of the wood is one critical factor to consider when either purchasing wood or assessing your stove's performance. The following is a list of wood species and their relative BTU content.

HIGH: Apple, Black Birch, Hickory, Hophornbeam, Locust, White Oak, Black Beech, Mesquite

MEDIUM HIGH: White Ash, Beech, Yellow Birch, Sugar Maple, Red Oak

MEDIUM LOW: Black Ash, White Birch, Grey Birch, Elm, Norway Pine, Pitch Pine, Black Cherry, Soft Maple, Tamarack

LOW: White Pine, White Cedar, Balsam Fir, Spruce, Aspen, Basswood, Butternut, Hemlock

Moisture content also plays a key role in the performance of your stove. Wood freshly cut from a living tree (green wood) contains a great deal of moisture. To properly season green wood, it should be split, stacked and allowed to air dry for a period of one year.

Ideally, firewood should be stacked on skids or blocks to keep it off the ground, and only the top of the stack should be covered. Plastic or tarps that cover the sides of the woodpile trap moisture and prevent the wood from drying. As for stacking, an old Vermonter said, "The spaces between the logs should be large enough for a mouse to get through, but not for the cat that's chasing it."

Firewood should not be stored within the stove's specified clearances to combustible materials.

D. OPERATING YOUR STOVE EFFICIENTLY

This stove is designed to burn firewood efficiently. The following operational tips will provide you with information on how to obtain the most heat possible with minimal creosote build-up and emitted pollutants.

HIGH HEAT

For maximum heat output, fully load the stove after the fire has been established and both the stove and chimney are hot. The primary air control should be at or close to the fully open position. When first engaging the stove in the high heat burn mode, monitor the stove temperatures frequently to ensure that the stove is not over-fired. The surface temperature on top of the stove should not exceed 600°F (315°C).

Once familiar with the operational characteristics of the stove in your particular setting you will easily engage the stove in the high burn mode without risk to the stove or chimney.

Once the temperature of the room is at a comfortable level, subsequent loadings of the stove should be of smaller quantities of wood. Burning smaller amounts of wood at a high rate of burn will result in the most efficient burn, the least emissions of pollutants and the least accumulation of creosote in the chimney.

OVERNIGHT BURN

The stove and chimney must be hot with an established fire prior to attempting an overnight burn. For an overnight burn, completely load the firebox with wood and, with the primary air control in the fully open position, allow the fire to burn intensely for 20 to 30 minutes. Now lower the primary air control to close to its lowest setting; the fire should settle into a low burn pattern with a small flame burning at a slow rate. The fire will now burn at a slow, steady rate depending on the primary air control setting, the type of wood being burned, the strength of the chimney draft and other variables which vary from installation to installation. The surface temperature on the top of the stove should not exceed 400°F (200°C) to achieve an overnight burn.

In the morning you should find a bed of hot coals buried within the ashes. The stove should be warm to the touch but not hot. To restart the fire without relighting, simply stir and rake the ashes with a poker until the hot coals have come to the surface. Place a handful of kindling on the coals, close the door and fully open the primary air control. The fire should reignite within 5 to 10 minutes. Place a few logs on the burning kindling, close the door, leave the primary air control fully open and allow the logs to ignite. Once the fire is burning briskly, regulate the primary air control to a medium setting for a moderate burn rate. The surface temperature on the top of the stove will run between 400°F (200°C) and 500°F (260°C) when in a moderate burn rate.

As it is recommended that you burn a hot fire at least once a day to burn off accumulated creosote from within the stove and venting system, it is good practice to burn the stove hot for 20 minutes or so every morning, especially after an overnight burn at a low rate of burn. This practice of a hot fire once a day will not only promote a clean stove and chimney, it will also help keep the glass clean for easy viewing of the fire within.

VI TROUBLESHOOTING

A. YOUR HEATING NEEDS

Virtually all woodstove operators experience basic common problems at one time or another. Most are correctable and generally require only a minor adjustment of the stove, installation, or operating technique. In cases where weather conditions dramatically affect stove performance, the problems are typically temporary and solve themselves once the weather changes.

If you question whether or not your stove is producing adequate heat, the best way to troubleshoot the problem is to monitor the temperature of the stack. A 400 degree F (200 degree C) stovepipe confirms the stove is supplying sufficient heat. Keep in mind that your house itself will regulate room/house temperatures. How well the walls, floors and ceilings are insulated, the number and size of glass windows, the tightness of outside doors, and the construction or style of your house (vaulted ceilings or other open spaces which collect large percentages of heat) all are determining factors of room temperature.

Your stove's performance is also dependant on its installation. One common cause of poor performance is an oversized chimney flue. Oversized chimney flues result in decreased pressure which prevents the smoke from rising out the chimney. Oversized flues are also more difficult to heat effectively, especially when burning a high efficiency stove. Cool flue temperatures inhibit the establishment of a strong draft (and encourage the accumulation of creosote). The lack of a strong draft will cause the fire to die down and may even force the smoke to pour into the room.

If your chimney is the proper size and a strong draft is not easily established, there is the possibility of the chimney being too cold. Again, hot chimneys promote a stronger draft.

Other draft guidelines are as follows:

AN "AIRTIGHT" HOUSE: If your home is super-insulated or especially well sealed, the (infiltration) air supply to the interior of the house may be inadequate. This phenomenon of air starvation within the building can be exacerbated if exhaust fans such as clothes dryers, bathroom fans or cookstove exhaust fans are in operation within the home. Outfitting your stove with the optional outside air supply adaptor connected to an air duct which leads to the outside of the building should correct this problem.

TALL TREES OR BUILDINGS in proximity to the top of the chimney can cause chronic or occasional down-drafts. When selecting a site for a new chimney, take care to consider the placement of other objects in the vicinity of the proposed chimney location.

WIND VELOCITY: Generally, the stronger and steadier a wind, the stronger (better) the draft. However, "gusty" wind conditions may cause erratic down-drafts.

BAROMETRIC PRESSURE: Chimney drafts are typically sluggish on balmy, wet or muggy days. This is a weather-related phenomenon which generally is self-correcting as the weather changes.

BRISKNESS OF FIRE: The hotter the fire in your stove, the hotter your chimney, and so the stronger the draft.

BREAKS IN THE VENTING SYSTEM: An unsealed clean-out door at the bottom of the chimney, leaky stovepipe joints, a poor stovepipe-to-thimble connection, or a leaky chimney may cause inadequate draft.

SEASONAL FACTORS: Early fall and late spring are generally difficult seasons in which to establish proper drafts. The colder the outside air (relative to room temperatures), the stronger the draft.

B. OPERATING THE STOVE

There are days when a draft is not easily established. As outlined above, seasonal factors or a cold chimney may be the cause. Try starting the fire by using small kindling and fuel to obtain a quick, hot fire. Tend the fire frequently with small fuel until the chimney is hot and the draft is well established.

C. TROUBLESHOOTING GUIDE

<u>PROBLEM</u>	<u>POSSIBLE CAUSE</u>	<u>SOLUTIONS</u>
STOVE SMOKES	Operating Technique:	Fully open the primary air control one minute before opening doors.
	Cold Chimney:	Preheat the chimney when first starting a fire.
	Blocked Chimney:	Examine the chimney and stovepipe for blockage or creosote accumulations.
	Oversized Chimney:	Reline the chimney to the appropriate diameter.
	Undersized Chimney:	Install a draft inducer or replace the chimney.
	Chimney Too Short:	Lengthen the chimney.
	Air Infiltration Into The Chimney:	Seal chimney connections and openings in clean-out doors.
BACK-PUFFING OR GAS EXPLOSIONS	More Than One Appliance Connected to the Flue:	Disconnect all other appliances and seal openings.
	Operating Technique:	Fully open the primary air control one minute before opening the door and keep it fully open for a few minutes after reloading.
	Extra Low Burn Rate:	Burn the stove at a higher burn rate.
	Chimney Down-draft:	Install a chimney cap.
UNCONTROLLED OR SHORT BURN	Excessive Ash Build-up:	Empty ash pan daily.
	Unsealed or Open Door:	Close the door tightly or replace the gaskets.
	Open Ash Grate:	Slide ash grate to closed position.
	Excessive Draft:	Check the installation. Operate at LOW BURN. Install stovepipe damper.
<u>PROBLEM</u>	<u>POSSIBLE CAUSE</u>	<u>SOLUTIONS</u>

UNCONTROLLED OR SHORT BURN	Deteriorated Cement Seals:	Reseal the stove with furnace cement.
	Extra Long Chimney:	Shorten the chimney. Install stovepipe damper.
	Oversized Chimney:	Reline the chimney to the proper diameter.
	High Winds or Hilltop Location:	Install a chimney cap.
	Excessive Draft:	Draft in excess of 0.1 wc should be corrected with a stovepipe damper.
INSUFFICIENT HEAT	Poor Quality or Green Wood:	Use only air dried wood, preferably dried <u>at least</u> one year.
	Low Burn Rate:	Operate the stove at a higher burn rate.
	Air Insulated Chimney:	Replace with a pre-fabricated insulated chimney system or a properly sized masonry chimney.
INSUFFICIENT HEAT	Exterior Chimney:	Insulate the chimney.
	Leaky Stovepipe or Chimney:	Check the installation.
	Too Much Heat Loss From House:	
	Leaky Stovepipe or Chimney:	Check the installation.
BLISTERING OF ENAMEL CASTING	Operating Technique:	Do not over-fire the stove. Monitor stove temperatures.
	Excessive Draft:	Check the installation. Operate the stove at a LOW BURN range.

VII REPLACEMENT PARTS

PART NUMBER:	DESCRIPTION:
CASTINGS	
2510-303	BOTTOM LEG
2010-100	BOTTOM
2010-300	SIDE LEG
2010-800	TOP
2010-500	FRONT DOOR
2010-550	GLASS RET FRAME
2010-600	FRONT DOOR FRAME
2010-200	ASH LIP
2610-011	ASH DOOR
2610-012	ASH DOOR FRM
2010-900	FLUE COLLAR
2610-017	GRATE FRAME
2610-018	GRATE
2610-054	AIR CONTROL HANDLE
STONE/ REFRACTORY	
1201-25	SOAPSTONE 8-1/32 X 9-1/2
1201-26	SOAPSTONE 8-1/32 X 9-1/2
1141-201	SOAPSTONE 7-3/64 X 8-7/64
1141-226	SOAPSTONE 6-5/16 X 9-1/2
1141-251	SOAPSTONE 2-3/4 X 9-1/2
1141-252	SOAPSTONE 4 X 9-1/2
1141-253	SOAPSTONE 2-19/32 X 9-1/2
3120-200	13"x 21"x 1" CERAMIC BLANKET 8# 2300DEG
STEEL SET	
5010-200	PRIMARY AIR PLENUM
5010-100	SECONDARY AIR PLENUM
5010-210	SECONDARY AIR PLENUM SUPPORT
5010-220	SECONDARY AIR RISER TUBE
5010-251	SECONDARY AIR TUBE #1
5010-252	SECONDARY AIR TUBE #2
5010-253	SECONDARY AIR TUBE #3
5010-254	SECONDARY AIR TUBE #4
5600-024	ASH PAN
5010-050	PRIMARY AIR INLET/ASH PAN BOX ASSY
5600-038	PRIMARY AIR CONTROL SLIDER
5600-051	PRIMARY AIR CONTROL SLIDER GUIDE UPPER
5600-050	PRIMARY AIR CONTROL SLIDER GUIDE LOWER
5600-039	PRIMARY AIR CONTROL ROD
5010-300	FRONT BAFFLE SUPPORT
5010-350	BAFFLE (2 REQ'D)
5400-2202A	ASH DOOR LATCH
5400-2206	FRONT DOOR LATCH
5400-2203	HANDLE CRANK
5400-2204	DOOR HANDLE ADAPTOR
5930-2010	HEAT SHIELD W/CLIPS (OPTIONAL)

MISCELLANEOUS

3030-026
6400-40411

DOOR GLASS 11-3/16"x17-21/32"x5mm
MANS OWNERS MANUAL

VIII SPECIFICATIONS**SPECIFICATION:**MAXIMUM HEAT OUTPUT¹HEAT-LIFE²

SIZE OF HEATED AREA

FIREBOX CAPACITY³

64 lbs of wood

MAXIMUM LOG LENGTH

HEIGHT (not incl. flue collar)

WIDTH

DEPTH (not incl. ash lip)

FRONT DOOR SIZE

STOVEPIPE SIZE

-METAL CHIMNEY

-MASONRY CHIMNEY

FLUE EXIT

ACTUAL WEIGHT

SHIPPING WEIGHT

CRATED DIMENSIONS

OPTIONAL EQUIPMENT

Outside Air Kit

Optional Blower

SOAPSTONE FINISH⁴

CASTINGS FINISH

MANSFIELD WOODSTOVE:

80,000 BTU/hour (cordwood)

14 hours

2,000 - 2,500 sq. ft.

3.2 CU FT³ (.091 m³)

21" (533 mm) Logs

27" (686 mm)

27" (686 mm)

24" (610 mm)

18" W x 12" H (457 x 305 mm)

6" (152 mm) diameter

6" (152 mm) inside diameter

6" (152 mm) inside diameter (round flue) or 8" x 8" (203 x 203 mm) (square flue)

Top Exit Only

550 lbs

580 lbs

H- 38" (965 mm) W- 32" (813 mm) L- 32" (813 mm)

Rear Heat Shield

Polished grey soapstone

Painted black matte and Porcelain enamel colors

¹ Based on independent laboratory test results.

² Heat-Life is a trademark of NHC, Inc. and is defined as thermal capacitance or quantity of heat stored. Used here, it refers not just to burn time, but also to hours of usable heat obtained from a single load of fuel.

³ The amount and weight of wood contained per cubic foot of firebox volume can vary from 15 to 36 lbs. per cubic foot depending on type of wood, moisture content, packing density and other factors. As a constant for comparison and test purposes, we are assuming 20 lbs. of seasoned hardwood per cubic foot of firebox volume.

⁴ Polished grey soapstone varies from grey to grey-blue, according to natural composition.

IX SAFETY LABEL

CONTACT YOUR LOCAL BUILDING AND INSTALLATION

OFFICIALS ABOUT RESTRICTIONS INSPECTION IN YOUR AREA

Listed Room Heaters, Solid Fuel Type
Also Suitable for Mobile Home Installation Pursuant to (UM)84-HUD

EESPC ENERGY AND ENVIRONMENTAL SYSTEMS PERFORMANCE CORPORATION
Kent, WA 98032
NVLAP LAB CODE 0301

Manufactured by:
NHC, INC.
P.O. Box 1069
Morrisville, VT 05661

"PREVENT HOUSE FIRES"

Install and use only in accordance with manufacturer's installation instructions and your local building codes.

CAUTION: Special methods are required when passing chimney through a wall or ceiling, refer to local building codes. Do not connect this unit to a chimney flue serving another appliance.

NOTE: Replace glass only with 5mm ceramic or NEOCERAM.

SERIAL NO.

MODEL NAME: MANSFIELD

TESTED TO: UL 1482

TEST DATE: June, 1995

REPORT NO. 95-065

TYPE OF FUEL: Solid Wood Only

WARNING: (MOBILE HOME) An outside air inlet must be provided for combustion, and unrestricted while unit is in use.

Minimum Clearances to Combustible Materials

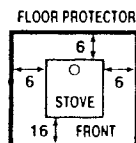
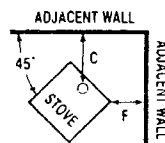
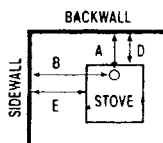

Floor protection must be 3/8" minimum thickness non-combustible material or equivalent, extending beneath heater and to the front / sides / rear as indicated.

Installation	Clearance	Chimney & Connector	Dimensions					
			A	B	C	D	E	F
Residential	Standard	Note: 1,4	24	34	29	23	25	20
Residential	Reduced	Note: 1,2	12	34	24	11	25	15
Residential	Reduced	Note: 2,3	12	34	24	11	25	15
Mobile Home	Standard	Note: 1,4	24	34	29	23	25	20
Mobile Home	Reduced	Note: 2,3	12	34	24	11	25	15

Note 1: 6" diameter, single wall, minimum 24 MSG or 25 MSG blued steel connector pipe with listed factory-built chimney suitable with solid fuels or masonry chimney.

Note 2: Rear heat shield required.

Note 3: 6" diameter DVL-Air insulated connector pipe with listed factory-built Class "A" chimney or masonry chimney. (Mobile Home equipped with spark arrester).

Note 4: Maintain 18" minimum clearance between horizontal chimney connector and ceiling.



CAUTION:

HOT WHILE IN OPERATION. DO NOT TOUCH. KEEP CHILDREN, CLOTHING AND FURNITURE AWAY. CONTACT MAY CAUSE SKIN BURNS. SEE NAMEPLATE AND INSTRUCTIONS. INSPECT AND CLEAN CHIMNEY AND CONNECTOR FREQUENTLY. UNDER CERTAIN CONDITIONS OF USE, CREOSOTE BUILDUP MAY OCCUR RAPIDLY. TYPE OF FUEL: SOLID WOOD ONLY

Date of Manufacture

1995 1996 1997 Jan. Feb. Mar. Apr. May June July Aug. Sept. Oct. Nov. Dec.

DO NOT REMOVE THIS LABEL

Made in U.S.A