

HearthStone I Owner's Manual

Congratulations on your purchase of a HearthStone H-I woodstove. You have made an investment in the finest solid fuel radiant and convection heater available today. To own a HearthStone stove is to make a statement of your appreciation and understanding of a quality handcrafted product.

Please read this manual in its entirety before installing and operating your H-I woodstove. The manual will familiarize you with the proper installation, break-in, operation and maintenance procedures. It contains information that will be useful to you now and in years to come, so keep it handy and refer to it as needed. **Failure to follow these instructions may result in property damage, bodily injury and loss of life.**

The performance of your H-I depends on many variables that make each installation unique. The sections in this manual provide general information, therefore, they can serve only as a useful guideline rather than offering hard and fast rules. Should you have any questions, do not hesitate to contact your dealer or NHC, Inc. for additional information.

Your HearthStone H-I woodstove is covered by a three year limited warranty. Please review the warranty provided with your stove. To activate your warranty, return the completed warranty validation form to N.H.C., Inc. Additional details are outlined on the warranty card.

CONSULT THE REGULATING AUTHORITY HAVING JURISDICTION (SUCH AS MUNICIPAL BUILDING DEPARTMENT, FIRE DEPARTMENT, FIRE PREVENTION BUREAU, ETC.) BEFORE INSTALLING THIS WOODSTOVE TO DETERMINE THE NEED FOR A PERMIT.

N.H.C., INC.
P.O. BOX 1069
MORRISVILLE, VT 05661
(802) 888-5232

SAFETY NOTICE: IF THIS STOVE IS NOT PROPERLY INSTALLED, A HOUSE FIRE MAY RESULT. FOR YOUR SAFETY, FOLLOW THE INSTALLATION DIRECTIONS. CONTACT LOCAL BUILDING OR FIRE OFFICIALS ABOUT RESTRICTIONS AND INSTALLATION INSPECTION IN YOUR AREA.

USE WITH SOLID WOOD FUEL ONLY

PART I. INSTALLATION	1
SECTION A: LOCATE YOUR STOVE FOR OPTIMUM COMFORT	1
SECTION B: CHIMNEYS	1
1. HOW CHIMNEYS WORK	1
2. WHAT IS DRAFT?	1
3. CHIMNEY SELECTION	2
SECTION C: FIREPLACE INSTALLATION	3
SECTION D: CHIMNEY CONNECTOR (STOVEPIPE)	4
1. INSTALLATION	4
2. STOVEPIPE MATERIAL	6
3. STOVEPIPE CLEARANCE	6
SECTION E: HEARTH	6
SECTION F: STOVE CLEARANCES	6
1. COMBUSTIBLE SURFACES	6
2. STANDARD MINIMUM CLEARANCES	7
PART II. OPERATION	7
SECTION A: THE CONTROLS	7
SECTION B: BREAK-IN	8
SECTION C: EVERYDAY USE	8
1. GENERAL GUIDELINES	8
2. OVERFIRING CAUTION	9
PART III. MAINTENANCE	10
SECTION A: DURING THE HEATING SEASON	10
SECTION B: AT SEASON'S END	11
SECTION C: STONE FINISH	12
SECTION D: CASTINGS	12
SECTION E: GLASS	12
1. Cleaning	12
2. Replacement	13
SECTION F: STOVEPIPE AND CHIMNEY	13
1. Inspection	13
2. Creosote	14
PART IV. SAFETY	14
SECTION A: GENERAL PROCEDURES	14
SECTION B: EMERGENCY PROCEDURES	15
PART V. TROUBLESHOOTING	15
SECTION A: SMOKING	16
SECTION B: SHORT BURN	16
SECTION C: INSUFFICIENT HEAT	16
PART VI. FIREWOOD INFORMATION	17
PART VII HEARTHSTONE H-I SPECIFICATIONS	18

PART I. INSTALLATION

SECTION A: LOCATE YOUR STOVE FOR OPTIMUM COMFORT

The useful heat output of your stove is delivered both as infrared radiation and heated air. Radiation directly warms the walls ceilings, furniture and all masses surrounding your stove. The air coming in contact with the stove is also heated and flows up and away from the stove to heat the room.

The H-I's soapstone walls produce an extremely even radiant heat that travels naturally to distant rooms, in most cases, no matter where you place the stove. By locating the stove centrally and providing for the free flow of heated air, you can maximize uniform comfort throughout your house. While not essential, an open floor plan is ideal. Ceiling-level registers and/or fans can help move warm air that collects at the ceilings.

Locating your stove in the basement is a great way to heat your basement, but not the rest of your home. The amount of radiant energy required to heat the basement's concrete walls is so great that most of the usable heat is absorbed by the concrete. In most cases your HearthStone belongs in your living area. Do not directly connect this heater to any air distribution duct.

SECTION B: CHIMNEYS

The performance of your HearthStone stove will largely depend on the chimney system. The stove and chimney should be thought of as one unit; neither is complete without the other. Balancing this system will be critical. Do not connect this stove to a chimney flue serving another stove or appliance.

1. HOW CHIMNEYS WORK

A chimney's function is to vent the smoke and gases safely out of your house and to supply the draft necessary to pull air into the firebox which keeps the fire burning.

2. WHAT IS DRAFT?

Buoyancy, or the tendency for hot air to rise, creates draft. When you start a fire in your stove, the hot exhaust gasses rise into your chimney and are vented outside. As the chimney gets hot, it assists in maintaining the draft. The hotter the chimney, the better the draft. This is why oversized chimney's should not be used, as they are difficult to heat. Often, until the chimney is sufficiently heated, draft is not adequate for optimum performance.

Location, size and height of your chimney all affect the draft. Consider the following:

- 2.1 Chimneys located inside the building stay hotter, so the draft is greater.
- 2.2 Properly sized chimneys maintain proper draft and flow as they are more easily heated.
- 2.3 Chimney height affects draft; the higher the chimney, the stronger the draft. Your chimney should be at least three feet higher than the point where it passes through the roof, or two feet higher than anything within ten horizontal feet.

Other factors that affect draft include:

- 2.4 Airtight, super-insulated homes usually require a supplemental outside air source.
- 2.5 Tall trees or buildings: Chronic or occasional downdrafts are often a result of nearby trees and buildings dampening the draft from outside.
- 2.6 Wind velocity: Generally, the stronger a steady wind, the stronger the draft. But gusty windy conditions may cause downdrafts.
- 2.7 Outside temperature: The colder the outside temperature, the stronger the draft.
- 2.8 Barometric pressure: On balmy, wet or muggy days, draft is generally sluggish.
- 2.9 Briskness of fire: The brisker the fire, the more draft.
- 2.10 Open cracks in the chimney, an unsealed clean-out door, leaky stovepipe joints, or another appliance vented into the same flue will cause poor draft.

3. CHIMNEY SELECTION

If you are planning to provide a new chimney for your HearthStone stove, you have two basic choices: a code-approved masonry chimney with a flue liner or a pre-fabricated metal chimney that comply with requirements.

Whenever possible your chimney should be located inside your house as it will draw better, accumulate less creosote and last longer.

3.1 MASONRY CHIMNEYS

A masonry chimney is made up of four basic parts: the foundation, the liner, the walls, and the clean-out door. Most building codes are based on NFPA 211, however, it is important to check with your local building officials to comply with local codes before the chimney construction begins. If you plan to use an existing chimney, it should be inspected by an authorized chimney sweep before it is used.

Masonry chimneys must be class A and lined. The fireclay flue liner must have a minimum thickness of 5/8-inch (or the equivalent). The liner must have a minimum of 1/2" air space between itself and the chimney walls to allow for heat expansion. See the following diagram for typical chimney construction.

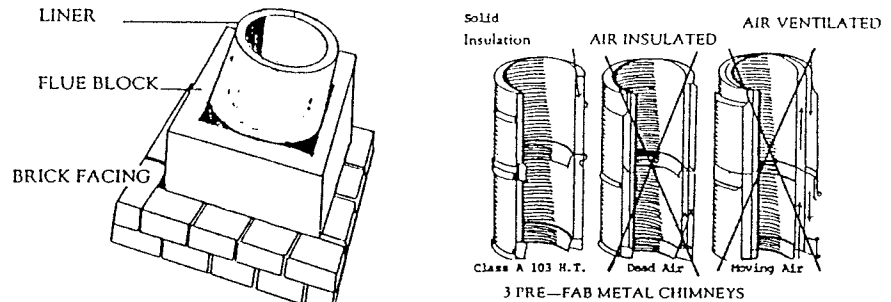

If constructing a chimney specifically for the H-I an 8" round flue is preferred due to its better flow characteristics. An 8" x 12" rectangular flue is acceptable, depending on other construction factors and location of the chimney (see Sections 2 and 3 above).

3.2 PRE-FABRICATED METAL CHIMNEYS

All pre-fabricated, factory-built chimneys for use in residences must be approved and listed in accordance with UL 103 HT. Only Class A, all fuel, factory-built chimneys should be used. Air-insulated, air-ventilated, or thermo-syphon chimneys can cause creosote to accumulate rapidly. When using a factory-built chimney, 8" diameter must be used for the H-I. **Never** use single wall pipe as a chimney.

SECTION C: FIREPLACE INSTALLATION

Existing fireplace flues are often larger than the size recommended for the H-I woodstove. If this is the case, lining the chimney with an 8" stainless steel liner is required. Likewise, any existing flue should be inspected before use. If the flue is not in good condition, it should be lined with an 8" stainless steel liner.

There are two methods for connecting the H-I to an existing fireplace, Method A and Method B. These methods are listed below and illustrated in Figures 1 and 2.

Method A: The stovepipe is connected directly into the existing masonry chimney above the fireplace opening (see Figure 1). Use NFPA 211 to specify wood trim and mantle clearances. A round fire clay liner (5/8-inch thick) or metal thimble should extend through the chimney wall to the inner face of the liner, but not beyond. The thimble should be permanently cemented into position. At least 8" of the flue liner must extend below this opening. Seal the flue below the opening with masonry.

Method B: The stovepipe is installed through the damper area of the fireplace (see Figure 2). The damper is normally replaced with a piece of sheet metal (24 gauge or heavier) fabricated to replace the damper. This new panel must be securely fastened to the damper frame. Refer to NFPA 211 for clearances to combustibles.

If it is not possible to put an adaptor in the existing damper frame, then an adaptor plate, also of 24 gauge or thicker, should be fabricated to fit in the chimney throat. The stovepipe must extend through the smoke chamber and into the tile lined flue. The stovepipe should be secured to the damper plate adaptor with sheet metal screws.

To ensure a good draft, all joints should be made airtight. Oversized chimneys should be lined completely. For additional information, refer to your local building codes or to NFPA 211.

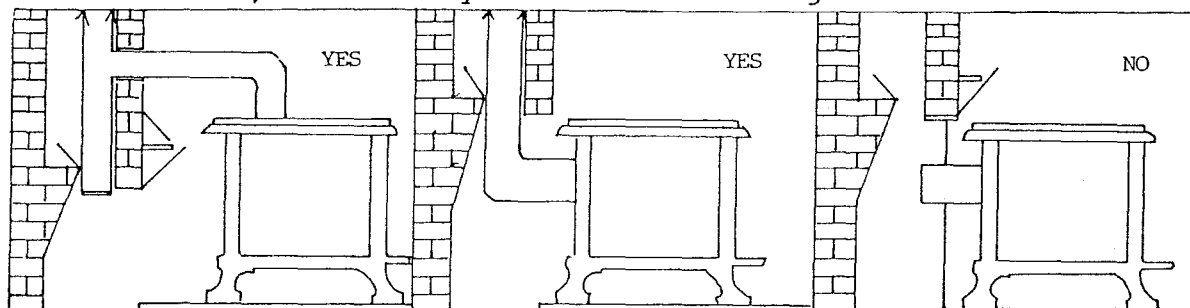

Method A
Figure 1

Method B
Figure 2

DO NOT USE
Figure 3

Do not install your stove as shown in Figure 3. The walls of the fireplace will act as a huge cooling surface. This can adversely affect the draft, promote creosote, and create back-puffing through the ignition of pooled unburned volatile gases.

SECTION D: CHIMNEY CONNECTOR (STOVEPIPE)

1. INSTALLATION

Chimney connector, commonly known as stovepipe, is used to connect the stove to the chimney. Since stovepipe is usually very hot, it must not pass through an attic or roof space, closet or similar concealed space, or a floor, ceiling, wall, or partition of combustible construction. Failure to comply with a proper stovepipe installation could result in a house fire. Follow the manufacturer's installation instructions.

- 1.1 The H-I has an 8" round flue collar which will accept the crimped end of a standard 8" stovepipe. The crimped ends of the stovepipe should always point down, toward the stove, and fit inside the flue collar, thus preventing creosote leakage.

1.2 Each stovepipe connection should be secured with three sheet metal screws. Secure the stovepipe to the flue collar using 3 sheet metal screws in the pre-drilled holes in the flue collar.

1.3 Long runs of single wall stovepipe should be avoided. The stovepipe connection should be between 3 and 7 feet if possible. Multiple elbows, which will restrict the flow, should also be avoided. Any horizontal run of stove-pipe should have a rise away from the stove 1/4" per foot of pipe.

1.4 Single wall stovepipe must never pass-through a wall or ceiling. This penetration should be made with a UL approved wall pass through system or as a part of an insulated chimney package containing the proper accessories. Once past the first wall or ceiling penetration the remainder of the chimney should be insulated pipe only. The stovepipe should extend into the chimney or chimney thimble at least 2", but not so far as to block air flow. Figure 4 shows a typical stovepipe assembly for a woodburning installation. Draw-bands, slip-joints and clean-out tees greatly simplify the connection of stove to chimney and allow for easy inspection and dismantling of the stovepipe without moving the stove.

1.5 The HearthStone H-I is equipped with an internal damper, therefore it is not necessary to install a damper in the stovepipe.

Make sure all stovepipe pieces are well-mated and secured with sheet metal screws. The entire connection should be very sturdy with little or no give or movement. Depending on the quality and

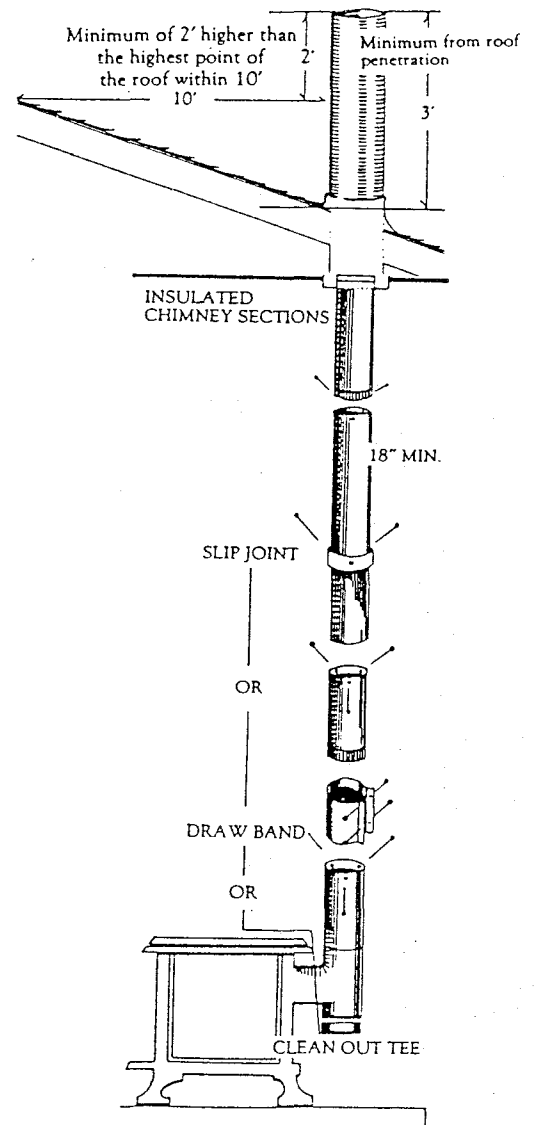

fit of your stovepipe, sealing the joints with furnace cement may or may not be necessary to assure air tight seams.

2. STOVEPIPE MATERIAL

Blue-steel, 24 gauge stovepipe, or heavier, must be used to connect your HearthStone H-I woodstove to the chimney flue. Use of aluminum Type B gas vent is unsafe and prohibited by the National Fire Protection Association code. Galvanized steel stovepipe is not acceptable for use with the H-I.

3. STOVEPIPE CLEARANCE

Stovepipe must be a minimum of 18" from any combustible surface or material (including the ceiling). However, keep in mind that the minimum clearances from combustibles for the stove may determine the overall clearances of the stovepipe.

SECTION E: HEARTH

Any wood or other combustible surface must be protected by a properly constructed hearth. Carpeting must be removed from the area directly under the hearth.

Floor protection must be 3/4" minimum thickness non-combustible material or equivalent with "R" factor = 0.75, extending beneath the stove and to the front, sides, and rear as shown in Figure 5. A bottom heat shield is required (U.S. installations). An acceptable floor protector consists of 4" of masonry mortared onto 28-gauge sheet metal which covers a plywood sub hearth.

FRONT:	24"
LEFT SIDE:	18"
RIGHT SIDE:	8"
REAR:	8"

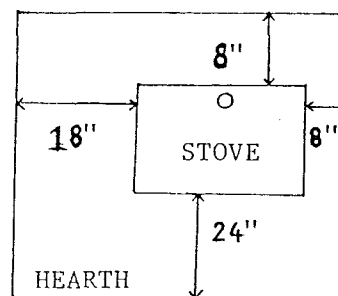

SECTION F: STOVE CLEARANCES

1. COMBUSTIBLE SURFACES

1.1 A combustible surface is one that has any combustible components, regardless of its covering. For example, a standard stud wall covered with sheetrock and further covered with brick is still considered a combustible surface. The brick can rapidly conduct heat to the sheetrock and studs.

1.2 Without adequate clearances, the wall material will dry

out over time and their ignition temperatures will be drastically reduced, therefore increasing the chances of spontaneous combustion.

1.3 Note: In some instances, local building codes may supersede HearthStone's requirements.

2. STANDARD MINIMUM CLEARANCES

2.1 The clearances illustrated in Figures 6 and 7 have been established for the HearthStone H-I woodstove in accordance with NFPA 211, and have been tested by Warnock Hersey International, an independent test laboratory.

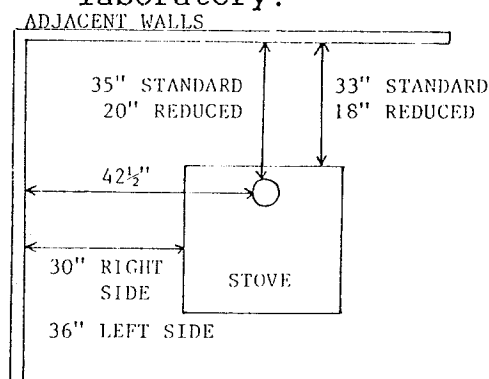

PARALLEL INSTALLATION
Figure 6

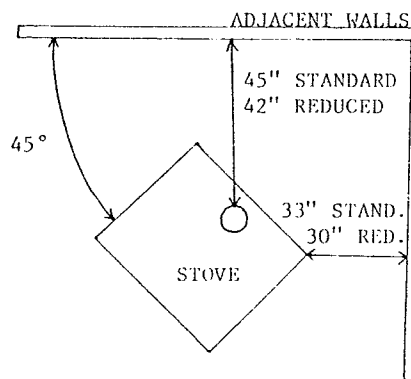

CORNER INSTALLATION
Figure 7

Reduced clearances must comply with NFPA 211 specifications, available from the National Fire Protection Association, 1 Batterymarch Park, P.O. Box 9101, Quincy, MA 02269-9101.

PART II. OPERATION

THIS STOVE IS DESIGNED TO BURN SOLID WOOD. DO NOT BURN COAL.

SECTION A: THE CONTROLS

Before lighting your first fire, familiarize yourself with the controls of your stove. Although operation is relatively easy, woodburning can be a complicated process with a great number of variables. It takes time and experimentation to understand how these variables interact in your particular installation. With a little patience, you will learn how to operate your stove to best suit your needs.

The internal damper is located just above the front door inside the stove. The damper is either in the open or closed position and is controlled by the damper control handle located on the left side of the stove above the side loading door. Rotate the

damper handle clockwise as far as it will go to open the damper; a counter clockwise rotation will close the damper. When closed, the damper slows the exit of smoke and gases when closed, which allows for a maximum heat transfer. When open, the smoke and gases encounter less resistance and are free to move easily up the stovepipe and into the chimney.

WHEN TO OPEN THE DAMPER:

- a. When starting a fire.
- b. For 5-15 minutes after reloading fuel.
- c. To "boost" the draft as necessary.
- d. Before opening either door to prevent a "backflash".

WHEN TO CLOSE THE DAMPER:

- a. Once the fire in your stove is well established to allow for maximum efficiency and heat transfer.

SECTION B: BREAK-IN

It is imperative that your stove be broken in slowly. There are several reasons why this is so:

1. Cast iron must be seasoned...overfiring a new stove may cause the bottom or other cast pieces to crack.
2. Moisture in the soapstone must be driven out slowly to minimize the "shock" to the stone during its first exposure to high temperatures.
3. Moisture in the asbestos-free furnace cement must be driven off slowly to ensure adequate sealing and bond.

To properly break-in the stove, build a small kindling fire on the bottom of the stove (there is no need for log racks or grates to support the fuel). Let this fire go out, completely. Repeat this process two more times.

SECTION C: EVERYDAY USE

1. GENERAL GUIDELINES

Once properly broken in, your HearthStone H-I woodstove is ready for continuous operation. The heat demands of your living area will determine how frequently you will have to load your stove. If the stove is not run continuously, we recommend a relatively low fire when starting a cold stove. Allow all the stone surfaces to become uniformly warm before a vigorous fire is made.

The following is a list of guidelines for everyday use:

- 1.1 Air for combustion must be provided to the stove while it is operating. Air-tight houses or houses having

- numerous exhaust fans may require supplemental air from outside the building to sustain proper combustion.
- 1.2 Do not use chemicals or fluids to start the fire. Do not burn garbage or flammable fluids such as gasoline, naphtha, or engine oil. Burn **only** solid wood fuel in this heater.
 - 1.3 Burn only well-seasoned, dry wood. Hardwood is preferable as it contains more BTUs per pound. Well seasoned firewood is wood which has been stacked and covered for a minimum of one year, and has a 16% to 20% moisture content. Do not store wood within the stove's installation clearances or within the space required for wood loading and ash removal.
 - 1.4 For maximum heat output, use maximum length firewood. The H-I will easily accommodate a 24" logs. Heat output can be lowered by using smaller or shorter pieces of wood. This is an effective way to regulate the stove for Fall and Spring burning.
 - 1.5 Whenever possible, reload onto a bed of hot, red coals. This will reduce smoking and will bring the fresh fuel up to a high temperature rapidly. Avoid hitting the kick plate and stones at the far end of the firebox when loading wood. Damage of this nature will not be covered by the warranty.
 - 1.6 Allow the fire to burn for 5 to 10 minutes after reloading before closing the internal damper.
 - 1.7 Avoid "one stick" fires. A good fire requires several logs in close proximity to maintain adequate temperatures for efficient combustion.
 - 1.8 Remove the ashes on a regular basis. Excessive ash build-up will reduce the heat output of your stove.
 - 1.9 Do not slam the front door or strike the door glass. Do not build a fire too close to the door glass. Do not use abrasive cleaners to clean the glass.

2. OVERFIRING CAUTION

Overfiring means running your stove at excessively high temperatures for extended periods of time. Because overfiring can cause damage to the stove and is extremely dangerous it should be avoided at all times.

Overfiring is a result of excessive draft which may be caused by the following:

- 2.1 Too much fuel in the firebox. Do not reload too often, or when a lot of fuel remains in the firebox. Do not try to see how much wood you can get into the stove as this will result in a fast, high temperature fire. A smaller charge of wood will burn more evenly and use less wood.

- 2.2 Venting the stove into an oversized chimney.
- 2.3 Lack of maintenance. The gasket in the side door should be changed as necessary (every 1-2 years).
- 2.4 Burning kiln dried wood (such as construction lumber), large amounts of kindling, extremely dry wood, or chemical fire starters or cleaners that cause excessively high temperatures.
- 2.5 Examples of damage done by overfiring are:
 - a. blistering or bubbling of enameled pieces
 - b. warpage of the internal firebox components
 - c. black stove paint that turns a whitish grey

ANY SYMPTOMS OF OVERFIRING WILL VOID YOUR WARRANTY.

PART III. MAINTENANCE

Your HearthStone H-I woodstove is subjected to temperature extremes and the corrosive residues of burning wood for long periods of time. Periodic maintenance is essential to keep your stove performing as it should. All parts and special maintenance kits are available through NHC, Inc. or your local dealer.

SECTION A: DURING THE HEATING SEASON

Everyday: Check the ash accumulation and remove the ashes as necessary. A moderate layer of ashes on the bottom of the firebox is useful to protect the bottom casting from the heat of the fire. However, ash should be removed when the depth of ash reaches the level of the door openings.

Every 2 weeks: Visually inspect the stovepipe and chimney for creosote accumulation. Accumulation of 1/8th inch or greater should be removed.

Every 8 weeks:

1. Check the tightness of the door frame bolts. Snug if necessary. Do not over-tighten.
2. Inspect the furnace cement seals between door frames and soapstone on the inside of the stove.
3. Check the door to frame fit of the side door by closing it on a dollar bill while the fire is out. If the dollar bill pulls out easily:
 - a) Tighten the set screw on the inside of the door latches.
 - b) Change the door gasket (side door only as the

- front door is not equipped with a door gasket).
- c) If this does not tighten the door, tighten the latch by removing one of the shim washers from the inside of the latch assembly and placing it on the outside. To do this, tap the pin out of the handle assembly with a 3/16" punch or blunt nail. Separate the inside latch from the outside handle. Take one washer from the catch side and place it on the latch side and reassemble.

Before, during and after the heating season, check the condition of the stovepipe and chimney regularly.

SECTION B: AT SEASON'S END

1. Dismantle the stovepipe and clean thoroughly. Replace any pieces that show any signs of deterioration or rust.
2. Clean the chimney. This should be done in the Spring at the end of the heating season. This will prevent the additional corrosion that can take place when moisture and creosote mix during the off season.
3. Clean and inspect the inside of the firebox.
4. Inspect the gaskets in the side door and around the door glass. Replace the gaskets if they are worn, frayed, cracked or extremely hard. Normally gaskets should be replaced every one to two years. Do not install a gasket around the front door perimeter. This unit is designed to receive combustion air into the firebox from around the edges of the front door.
 - 4.1 To replace the side door gasket start by pulling the worn gasket from the channel. Clean the loose debris from the channel (a wire brush works best). Apply a fine bead of gasket cement to the channel. Pack the replacement gasket into the channel without stretching it.
 - 4.2 To replace the door glass gasket, first remove the glass from the door frame as described elsewhere in this manual. A pre-glued 3/4" flat gasket is then wrapped around the glass. Re-assemble the glass within the door frame. The retention clips should be secure but not over-tightened.
5. Repaint castings, as required.
6. Review the instructions for "Every 8 weeks", above.

NOTE: Gasket kits, cement and high temperature paint are

available from your dealer or NHC, Inc.

SECTION C: STONE FINISH

Occasional cleaning is all that is required to maintain your polished soapstone finish. Care must be taken, however, not to scratch or chip the stone surface. Any liquid, non-abrasive cleaner (a mild detergent diluted in water is fine) is suitable. Any residue left by the cleaner can be removed with standard glass cleaner.

Often, with use, subtle earth stones of brown, red and yellow appear in the soapstone. This is a natural reaction in the soapstone. Also, upon close inspection, surface or hairline cracks may be evident. Hairline cracks are on the surface only and will not affect the integrity or operation of the stove.

NOTE: The stove should be cleaned only when the fire is out and the stove cool. The first fire after a cleaning should be a break-in fire as described elsewhere in this manual to drive off any residual moisture.

SECTION D: CASTINGS

Black Cast Iron: Clean the painted cast iron with a damp sponge. Wipe the castings dry with a soft cloth after cleaning. High temperature stove paint is available from your dealer or NHC, Inc. when repainting is desired. Surface rust and other loose debris should be removed with steel wool or a wire brush before applying the paint.

Porcelain Enamel Finishes: Standard glass cleaner is effective on the enamel finish. Tougher spots can be removed by using a fine steel wool (type 00). If a chip develops in the finish, touch up kits are available for each enamel color. With time and use, a very fine subtle network of craze lines may appear seemingly beneath the surface of the enamel. Crazeing is a natural process and does not represent a flaw. However, overfiring will severely damage the enamel. Evidence of overfiring would include bubbling, blistering or severe cracking in the enamel. This will only occur under extreme conditions. Damage due to overfiring will not be covered by the warranty.

SECTION E: GLASS

WARNING: DO NOT STRIKE THE GLASS, OR SLAM THE FRONT DOOR.

1. Cleaning

Combustion air entering the firebox around the front door will keep the door glass clean. Light deposits of soot or ashes can be cleaned with a standard glass cleaner. If it is necessary to clean the glass, make sure the fire is out

and the glass is cool. Do not use abrasive cleaners. Do not build fire too close to the glass.

2. Replacement

Do not operate the stove with broken glass; replace cracked or broken glass immediately. The glass in the H-I woodstove is a thermal, shock-resistance ceramic glass made specifically for use in woodstoves. **Never** substitute common glass or pyrex as a replacement. Contact your dealer or NHC, Inc. for the proper replacement glass and gasket.

To replace your glass:

- 2.1 Remove the door from the stove by lifting the door off its hinges. Tap the hinge pins with a punch and hammer if necessary.
- 2.2 Place the door face down on a flat, smooth surface.
- 2.3 Remove the screws holding the clips which hold the glass within the door frame.
- 2.4 Carefully remove and discard the damaged glass.
- 2.5 Peel the paper backing off the flat gasket provided with the replacement glass kit. Wrap the gasket around the edge of the glass. Apply the gasket as shown in Figure 8 so that there is a larger amount of gasket on one side of the glass to act as a cushion. This thicker, cushioned edge should be placed against the front door upon reassembly.

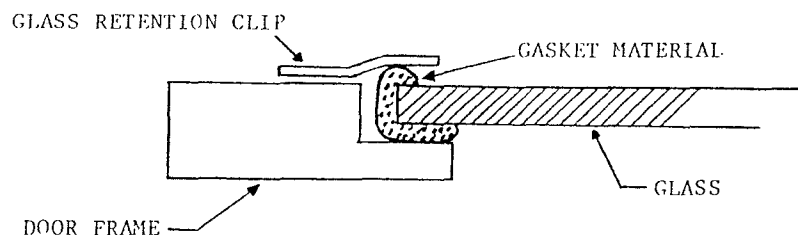

- 2.6 Replace the clips and screws.
- 2.7 Hang the door onto the door frame. Tap the hinge pins back into position if necessary.

SECTION F: STOVEPIPE AND CHIMNEY

The condition of the stovepipe and chimney must be inspected regularly before, during and after the heating season.

1. Inspection

Clean-out tees, slip-joints, and draw-bands are stovepipe components that simplify inspection and cleaning of the stovepipe and chimney. A clean-out tee allows the chimney

to be cleaned without dismantling the stovepipe. A slip-joint or draw-band allows the pipe to be dismantled and cleaned outdoors. A small mirror with an angled handle allows for easy inspection of the chimney once the pipe has been separated.

A masonry chimney can be inspected using a long handled mirror through the clean-out door. If there is no clean-out door, the flue should be inspected through the thimble, the fireplace damper, or from the top.

2. Creosote

When burned slowly, wood can produce tar and other vapors which combine with moisture to form creosote. The creosote vapors can condense in the relatively cool chimney flue of a low burning fire and accumulate on the flue lining. When ignited, this creosote can produce a very hot, potentially damaging fire. A creosote accumulation of 1/8" or greater should be removed immediately. Visual inspections should be performed frequently. On a new installation, the stovepipe should be inspected every two weeks to guard against a creosote buildup. If the pipe stays clean, inspect the system on a monthly basis.

The use of chemical compounds, salt, potato peelings, or other agents designed to eliminate creosote is **not** recommended. The only effective way to clean your chimney is by brushing with the properly sized brushes. This can be done by the homeowner, however, a certified, professional chimney sweep is best equipped to do the job. A hard creosote glaze often requires cleaning by a professional. **Never** attempt to clean a chimney by burning it out.

PART IV. SAFETY

SECTION A: GENERAL PROCEDURES

There are certain risks associated with the use of any solid fuel heater. However, these risks can be minimized if proper installation and sensible operating techniques, as outlined in this manual, are followed. Additionally, we urge your to use common sense.

The following is a list of safety precautions:

1. Always keep combustible items the proper distance from the stove. Review the section on Stove Clearances elsewhere in this manual.
2. Do not overfire the stove. If the stovepipe glows, you are overfiring. If the cast iron begins to creak or

change color, or if the porcelain finish starts to blister, the stove is being overfired.

3. Install a smoke alarm.
4. Keep a fire extinguisher handy. We recommend the type rated A,B,C.
5. Ashes removed from the stove should be placed in a small metal container with a tight fitting lid. The closed container of ashes should be removed from the house immediately. Other waste material should not be placed in the ash removal container. In order to prevent fires at the ash disposal area, ashes must be retained in the closed container until all cinders have cooled **completely**. Use extreme caution in the disposal of ashes as cinders can retain their heat for 24 hours or more within a bed of ashes.
6. **Never** use gasoline, lantern fuel, kerosene, charcoal lighter fluid or similar liquids to start or "freshen-up" a fire. Keep all such liquids well away from the stove while it is in use.
7. Keep children and pets away from the stove.
8. Inspect and clean the stovepipe and chimney frequently to guard against creosote accumulation. Under certain conditions of use, creosote build up may occur rapidly.
9. Remember that heating with a woodstove is a serious responsibility. Failure to do so could result in a house fire. Misuse or abuse can affect you, your family and friends. Follow the procedures and cautions outlined in this manual and warm your home safely.

SECTION B: EMERGENCY PROCEDURES

In the event of a stovepipe or chimney fire:

1. Close the damper.
2. Call the Fire Department or local authorities for information on how to handle a chimney fire. Have a clearly understood plan to handle a chimney fire.
3. Keep an eye on the stove, stovepipe, and chimney.
4. Be prepared to evacuate the house if the situation worsens.

Once the chimney fire is out, let the fire in the stove go out, too. The stove should not be fired again until the stove, stovepipe and chimney are all thoroughly inspected for damage by your fire department or a certified chimney sweep. Damage must be corrected before the stove is used again.

PART V. TROUBLESHOOTING

The following is a list of problems that are common to all wood burners at one time or another. All the problems are

correctable, and, often times, require only a minimal adjustment of the stove or operating technique. Remember that the weather conditions can drastically effect stove performance. Most problems caused by a change in the weather are temporary in nature.

SECTION A: SMOKING

If your stove smokes when you open the loading door, it is usually caused by insufficient draft. Inspect your stovepipe and chimney for creosote accumulation and clean, if necessary. If the insufficient draft is caused by an improperly sized chimney, installation of a draft inducer or raising the height of the chimney may be required. However, the best cure is to rebuild the chimney to the proper specifications for the woodstove in use.

Smoking may also be caused by restrictive airflow in the chimney. If the outside temperature is mild, open the damper for a moment or two before opening the door. This will invigorate draft. If your stove smokes consistently and is vented into a proper chimney, crack open a window in the same room. If this corrects the problem, it is an indication that your house is so airtight that the introduction of a supplemental supply of outside air may be necessary for proper stove operation.

SECTION B: SHORT BURN

The HearthStone H-I is a non-controlled combustion woodstove which operates in a manner similar to an open fireplace. In general, long, slow burns are not possible with this stove. Useful, longterm heat output is obtained from a large fire (full firebox) and "heat life" (thermal capacitance, or quantity of heat stored) of the 750 pound mass of the stove.

Maximum burn time is achieved when the fuel used is hardwood cut to the maximum length. Burning softwoods, and burning pieces that are small in diameter or short, contribute to shorter burns.

Make sure that the internal damper is moved to the closed position once the firebox is loaded and the fire burning briskly.

Normally a new gasket is all that is necessary to repair a leaky side door seal. Contact your dealer or NHC, Inc's Service Department if further assistance is necessary.

SECTION C: INSUFFICIENT HEAT

If your stove is not producing adequate heat (if you can not constantly reach a surface temperature of 450+ F), check the clean-out door, pipe connections and flue to be sure all connections are tight. Any breach in the chimney should be

properly sealed. The stove should not share the flue with another appliance. A large volume of ashes in the firebox will insulate the stove and reduce the heat transfer.

Green wood and wet wood will greatly reduce the heat output of the stove.

PART VI. FIREWOOD INFORMATION

The quality of your firewood is an important variable which impacts both heat output and duration of burn. Softwoods generally burn hotter and faster, while hardwoods burn longer and produce more coals. The density of wood is a critical factor to consider when purchasing wood or assessing your stove's performance. For your reference, the following is a list of wood species and their relative BTU content.

HIGH ENERGY CONTENT

Ash, Black Birch, Hickory, Locust, White Oak, Black Beech

MEDIUM HIGH CONTENT

White Ash, Beech, Yellow Birch, Sugar Maple, Red Oak

MEDIUM LOW ENERGY CONTENT

Black Ash, White Birch, Grey Birch, Elm, Norway Pine, Pitch Pine, Black Cherry, Soft Maple, Tamarack

LOW ENERGY CONTENT

White Pine, White Cedar, Balsam Fir, Spruce, Aspen, Basswood, Butternut, Hemlock

Moisture content also plays a role in the performance of your stove. Wood that is freshly cut from a living tree has a great deal of moisture in it. To properly season green wood, it should be split and stacked for a period of six months to a year. Ideally, it should be stacked on skids or blocks to keep it off the ground, and only the top should be covered. Covering the sides with a tarp or plastic will trap the moisture and prevent wood from drying.

PART VII HEARTHSTONE H-I SPECIFICATIONS

Maximum Heat Output.....	100,000 BTU/hr ¹
Heat-Life ^{2 tm}	Up to 12 hrs maximum
Size of Heated Area.....	Up to 24,000 cu. ft.
Fuel Load.....	5.2 cubic ft.
Log Length.....	24" - 26" logs
Height.....	34"
Width.....	33"
Depth.....	28"
Fireplace Door.....	13-3/4"H x 17-1/2"W
Side Loading Door.....	13-5/8"H x 11-1/4"W
Stovepipe Size.....	8" inside diameter
Flue Exit.....	Reversible, top or rear exit
Rear Flue Exit Center Line.....	25" from the floor
Primary Air.....	Fixed amount; enters firebox around front door
Actual Weight.....	750 lbs
Shipping Weight.....	785 lbs
Soapstone Finishes.....	Polished grey or brown soapstone
Casting Finishes.....	Painted black matte or brown, black, colonial blue, or almond porcelainized enamel

(1) Estimate based on Hearthstone Independent Laboratory combustion efficiency test results.

(2) Heat-Life is a trademark of NHC, Inc., and is defined as thermal capacitance, or the quantity of heat stored. Used here, it refers to hours of usable heat obtainable from a single load of wood. The area heated and duration of burn may vary from installation to installation.

TESTING LAB:



Warnock Hersey

WARNOCK HERSEY INTERNATIONAL, INC.
8431 MURPHY DRIVE, P.O. BOX 735, MIDDLETON, WI 53562
TEL (608) 836-4400 · FAX 608-831-9279