



Castleton I

(Model 8031)
Woodstove

OWNER'S MANUAL

Installation And Operating Instructions



We recommend that our products be installed and serviced by professionals who are certified in the U.S. by NFI (National Fireplace Institute).

www.nficertified.org



**SAVE THIS OWNER'S MANUAL
FOR FUTURE REFERENCE**

**PLEASE READ THIS ENTIRE OWNER'S MANUAL BEFORE YOU INSTALL AND USE YOUR
NEW CASTLETON 8031 WOOD STOVE.**

If this room heater is not properly installed, a house fire may result.

To reduce the risk of fire, follow the installation instructions.

Failure to follow these instructions can result in property damage, bodily injury, or even death.

Conforms to UL Std. 1482

Certified to ULC Std. S627

**CONTACT LOCAL AUTHORITIES WITH JURISDICTION (BUILDING DEPARTMENT or FIRE
OFFICIALS), ABOUT PERMITS REQUIRED, RESTRICTIONS AND INSTALLATION
INSPECTION IN YOUR AREA.**

California Prop 65

⚠ WARNING: This product can expose you to chemicals including glass wool fiber and carbon monoxide which are known to the State of California to cause cancer, birth defects or other reproductive harm. For more information go to www.P65Warnings.ca.gov

Castleton I (Model 8031)

Manual: 6400-41406

R: 02/20/18

NOTES ON STOVE OPERATION AND EFFICIENCY

Rating:

You have purchased a Hearthstone Castleton 8031 tested to EPA Method 28R 40 CFR Part 60 where applicable. This stove is certified to comply with the U.S. Environmental Protection Agency 2020 particulate emissions standard using crib wood. It is certified at 0.7 gr/hr. emission rate and under specific test conditions has been shown to deliver heat at rates ranging from 13,781 to 24,292 Btu (output).

This wood heater has a manufacturer-set minimum allowable low burn rate that must not be altered. It is against federal regulations to alter this setting or otherwise operate this wood heater in a manner inconsistent with operating instructions in this manual.

Please refer to the Warranty section of this manual for registration instructions. In case of warranty claims, please contact the point of original sale or the nearest authorized Hearthstone dealer. Our dealer network processes all warranty claims. Authorized Hearthstone dealers can be located at www.hearthstonestoves.com.

This heater is designed to burn natural wood only. Higher efficiencies and lower emissions generally result when burning air-dried seasoned hardwoods, as compared to softwoods or to green or freshly cut hardwoods. **DO NOT BURN:** *Garbage, lawn clippings, material containing rubber (including tires), materials containing plastic, waste petroleum products paints or paint thinners, asphalt products, materials containing asbestos, construction or demolition debris, railroad ties, pressure treated wood, manure or animal remains, salt water driftwood or other previously salt water saturated materials, unseasoned wood, paper products, cardboard, plywood or particleboard.* This prohibition against burning these materials does not prohibit the use of fire starters made from paper, cardboard, sawdust, wax and similar substances for the purpose of starting a fire in an affected wood heater. Burning these materials may result in a release toxic fumes, render the heater ineffective, cause smoke and may damage catalysts.

Following the maintenance guidelines set forth in this manual will help insure the efficient use of your wood heater and minimize visible emissions. Having your stove inspected by a trained professional on a regular basis will greatly increase the potential for recognizing possible impacts to efficiency.

Proper draft is important to the efficient operation of your heater. Refer to the Normal Operation section of this manual for information regarding adequate draft. Both excessive and sub-minimum draft can affect the efficiency of your wood heater. Excessive draft can lead to over-consumption of fuel, lower overall heating capacity of the stove and potential over firing. Low draft can result in inefficient burns, low heat output, expulsion of smoke into the living area when stove doors are opened and an increased potential for build-up of flammable materials in the flue.

Efficiency:

Efficiency was measured and weighted using EPA Method 28R and CSA B415-10 methodology. A weighted average was used to calculate the overall efficiency across all of the 4 burn rate categories using the higher heating value (HHV). The weighted average efficiency is 77% (HHV).

To maximize the efficiency of your wood stove make sure it is sized properly for the space you plan to heat. An oversized stove will often be forced to burn at a lower and dirtier burn rate. Consult with your dealer for sizing and correctly placing the stove in your home. An incorrectly placed stove can greatly reduce efficiency. Maximizing the efficiency of your stove will heat your house quickly, burn cleaner and use less wood.

Refer to the Choosing Firewood section of this manual for appropriate fuel selection. Seasoned firewood is typically at or near 20% moisture content. This can be measured with any number of hand-held moisture meters available through your local hearth shop. Follow instructions included with the meter you purchase to measure fuel wood moisture content. Burn only dry, seasoned wood as using wet wood will greatly reduce your efficiency.

CO Emissions:

The Castleton 8031 has the following CO emission rates by burn level: Category 1 (low) – .57 g/min., Category 2 (med. low) – .47 g/min., Category 3 (med. high) – .60 g/min. and Category 4 – 1.55 g/min. Wet wood or unapproved fuel described above can greatly affect the emissions of a wood burning stove.

Smoke/Fire/CO Detectors:

It is highly recommended that smoke and CO detectors be installed throughout the heated space when a wood burning heater is installed. Be certain to install these devices not only in the area where the wood appliance is located, but also in bedrooms, hallways leading to other areas of the house and all common areas of the heated space. Check the batteries in these devices and assure operation by performing whatever test operations are recommended by the manufacturer.

TABLE OF CONTENTS

INTRODUCTION	3
CODES.....	3
SAFETY INFORMATION	3
PERIODIC CHECKLIST	4
EMERGENCY PROCEDURES	5
SPECIFICATIONS	6
INSTALLATION	7
UNPACKING.....	7
PACK LIST.....	7
INSTALLING YOUR STOVE.....	7
HEARTH REQUIREMENTS & FLOOR PROTECTION.....	8
COMBUSTIBLE SURFACE REQUIRED CLEARANCES	9
CHIMNEY CONNECTOR SYSTEMS AND CLEARANCES FROM COMBUSTIBLE WALLS.....	11
OUTSIDE AIR SUPPLY	12
VENTING COMPONENTS & CONFIGURATION REQUIREMENTS	13
INSTALLING IN A MOBILE HOME.....	17
OPERATION	18
CONTROLS AND FEATURES	18
BUILDING A FIRE	20
BREAKING IN YOUR WOOD STOVE	20
NORMAL OPERATION	21
CATALYTIC COMBUSTOR OPERATION	22
MAINTENANCE	23
CATALYTIC COMBUSTOR INSPECTION AND REPLACEMENT PROCEDURES	23
INSPECTING THE CATALYST	24
REPLACING THE CATALYST	25
REPLACING THE BAFFLE.....	26
GLASS REPLACEMENT PROCEDURES	27
CREOSOTE FORMATION & REMOVAL	27
GASKETS	27
GLASS	28
TROUBLESHOOTING	28
TROUBLESHOOTING GUIDE	30
REPLACEMENT PARTS & OPTIONAL ACCESSORIES.....	32
SAFETY LABEL	33
WARRANTY	34

INTRODUCTION

Thank you for purchasing a Castleton 8031 woodstove from Hearthstone Quality Home Heating Products. This stove will provide years of comfortable heat. This stove combines the warmth and comfort of soapstone and cast iron with the efficiency of advanced catalytic technology. The Castleton 8031 blends modern technology with the unique beauty and qualities of cast iron. We trust that you will appreciate the quality of this handcrafted product.

Your Castleton 8031 woodstove burns very efficiently, and produces a large amount of heat. However, you should not consider your Castleton 8031 the primary heat source for your home. The Castleton 8031's large glass window allows you to enjoy the fire from a variety of locations in the room.

Please read this manual in its entirety. Its purpose is to familiarize you with your stove's safe installation, proper break-in, operation and maintenance. It contains extremely important information so keep it handy and refer to it often.

A qualified heating technician may need this owner's manual as a reference when installing this stove in your home. There are national, state, and local building codes that direct the technician on how to install your stove. These codes stipulate the dimension of stovepipe and clearances to walls, ceilings, hearth, and other combustible surfaces. The codes exist to reduce the risk of fire. Failure to follow these instructions can result in fire, property damage, bodily injury, and even death.

Install the stove in a safe, open area, away from traffic flow, doors, and hallways. If possible, try to install the stove near an existing chimney and chimney connector. It is extremely important to install this stove with the proper clearance from combustible surfaces. You can purchase specific connector pipe and special wall coverings as specified by this manual and the NFPA 211 code to protect combustible surfaces. As a general rule, keep furniture, drapes, curtains, wood, paper, and other combustibles at least 36 inches (92 cm) away from the stove. Never install the stove in or near a storage location for gasoline, kerosene, charcoal lighter fluid or any other flammable liquids.

Install the stove in your central living area to allow heat to radiate naturally to distant rooms. Do not install your stove in a poorly insulated area. This is inefficient and would likely result in higher fuel usage.

- **SAFETY NOTICE:**

AN IMPROPERLY INSTALLED STOVE CAN RESULT IN A HOUSE FIRE. FOR YOUR SAFETY, CAREFULLY FOLLOW THE INSTALLATION DIRECTIONS. CONTACT LOCAL BUILDING OR FIRE OFFICIALS ABOUT RESTRICTIONS AND INSTALLATION INSPECTION IN YOUR AREA.

The safety of your stove will depend on many factors, some of which include: distance to combustible objects, correct venting, and adequate chimney maintenance. Should you have any questions, do not hesitate to contact your dealer for additional information.

Contact your dealer for any necessary warranty service.

This Castleton 8031 stove is warranted by:

Hearthstone Quality Home Heating Products, Inc®
317 Stafford Ave.
Morrisville, Vermont 05661, USA
www.Hearthstonestoves.com

CODES

When you install your Castleton 8031 woodstove, it is imperative that you adhere to all Federal and local codes. Obtain these codes from either of the following sources:

American National Standards Institute, Inc. (ANSI)
1430 Broadway
New York, NY 10018
www.ansi.org

National Fire Protection Association, Inc. (NFPA)
Battery March Park
Quincy, MA 02269
www.nfpa.org

If you are installing your Castleton 8031 in a mobile or manufactured home, follow the guidelines described in the Manufactured Home Construction and Safety Standard, Title 24 CFR, Part 3280 (United States).

SAFETY INFORMATION

Read and understand this Owner's Manual thoroughly before installing and using this stove.

Make sure to install your stove:

- According to the manufacturer's recommendations
- In accordance with all applicable codes
- With the proper sized chimney

When using your stove, follow these safety precautions:

- **Never** modify this stove in any way.
- **Never** burn kiln dried, painted or treated wood in this stove.
- **DO NOT BURN GARBAGE.** **Never** burn garbage or trash, colored or glossy paper, solvents, plywood, artificial logs, cardboard, or driftwood, in this stove.
- **Never** burn coal in this stove.
- **DO NOT BURN FLAMMABLE FLUIDS.**
- **DO NOT USE CHEMICALS OR FLUIDS TO START THE FIRE.** **Never** use gasoline, kerosene, charcoal lighter fluid, or other flammable fluids to start or invigorate the fire. These fuels will cause dangerous burning conditions in the stove. Keep all such materials away from the stove.
- **Never** use a wood grate or other device to elevate the fire.
- **Never** allow logs in the firebox to hit the glass when the door is closed.
- **Never** slam the door or use the door to force wood in to the stove.
- **Never** over-fire your stove. (See page 22)
- **Never** put articles of clothing or candles on a hot stove.
- **Never** connect the stove to a flue used by another appliance.

Other safety guidelines:

- Keep all combustible items such as furniture, drapes, clothing, and other items, at least 36" (0.92 m) from the stove (See page 8)
- Install a smoke detector, preferably in an area away from your wood stove.
- Keep a fire extinguisher handy. We recommend the type rated "A B C."
- Dispose of ashes properly (See page 23).

- Keep children and pets away from the stove when it is burning; they could be seriously injured by touching a hot stove.
- Clean your chimney system as needed. (See page 28)
- Outside combustion air may be required if:
 1. This solid-fuel-fired appliance does not draw steadily, smoke rollout occurs, fuel burns poorly, or back-drafts occur whether or not there is combustion present.
 2. Existing fuel-fired equipment in the house, such as fireplaces or other heating appliances, smell, do not operate properly, suffer smoke roll-out when opened, or back-draft whether or not there is combustion present.
 3. Opening a window slightly on a calm (windless) day alleviates any of the above symptoms.
 4. The house is equipped with a well-sealed vapor barrier and tight fitting windows and/or has any powered devices that exhaust house air.
 5. There is excessive condensation on windows in the winter.
 6. A ventilation system is installed in the house.

If these or other indications suggest that infiltration air is inadequate, additional combustion air should be provided from the outdoors. Outside combustion air can be provided to the appliance by using the optional outside air kit #90-53300

PERIODIC CHECKLIST

Perform each of these tasks at the specified intervals.

At the End of Every Week:

- Empty ashes from the firebox, sooner if the firebox is full.

At the Beginning of Every Other Month:

- Depending upon your use of the stove, visually inspect the chimney connector and chimney for creosote. (see page 28)
- Check door seals using the "dollar bill test." - When the stove is cool, shut the door on a dollar bill. If the bill pulls out without any resistance, then your stove's door is not sealing properly. To tighten the seal, adjust the door latch mechanism or change the door gasket. (Refer to page 28.)

- Inspect the face of the catalytic combustor for fly ash and soot. Use a soft-bristled brush to remove if present. It is recommended to visually inspect the catalytic combustor at least 3 times during the heating season, or every 2-3 months.

At the End of Every Season:

- Dismantle the chimney connector and clean it thoroughly. Replace any pieces that show signs of rust or deterioration.
- Inspect and, if necessary, clean your chimney.
- Clean out the inside of the stove thoroughly.
- Check and clean the catalytic combustor, if necessary
- Inspect all door gasket material and replace if worn, frayed, cracked or extremely hard.

EMERGENCY PROCEDURES

Establish a routine for the fuel, wood burner and firing technique. Check daily for creosote build-up until experience shows how often you need to clean to be safe. Be aware that the hotter the fire the less creosote is deposited, and weekly cleaning may be necessary in mild weather even though monthly cleaning may be enough in the coldest months. Contact your local municipal or provincial fire authority for information on how to handle a chimney fire. Have a clearly understood plan to handle a chimney fire

If you have a stovepipe or chimney fire, follow these instructions:

1. If the fire is too threatening, leave the area and call the fire department immediately! If not, perform the next three steps.
 2. Close the primary air control.
 3. Close the stovepipe damper (if present).
 4. Close the bypass damper
 5. Keep the stove front door closed!
- **WARNING: DO NOT ATTEMPT TO PUT OUT A STOVEPIPE OR CHIMNEY FIRE BY THROWING WATER ONTO THE STOVE, STOVEPIPE, OR CHIMNEY. THE EXTREMELY HIGH TEMPERATURE OF SUCH FIRES CAN CAUSE INSTANTANEOUS STEAM AND SERIOUS BODILY HARM.**

Once the chimney fire expires, leave the primary air control and bypass handle closed and let the fire in the stove die out completely. Inspect the stove, stovepipe, and chimney thoroughly for any sign of damage before firing the stove again. You must correct any damage before using your stove again.

SPECIFICATIONS

Maximum Heat Output:

45,000 BTUs per hour of cordwood (based on independent laboratory test results).

Floor Size of Heated Area:

Up to a maximum of 1,500 square feet. Factors unique to your home can reduce the square footage the stove will heat. Home insulation value, number and efficiency of windows, floor plan, stove placement, quality of the fuel and other conditions may limit the heating ability of the stove.

Firebox Capacity:

1.9 cubic feet.

Maximum Log Length: Up To 18" (45.7cm).

Emissions: 0.7 g/hr.

Burn Time: Up to 20+ hrs. (*Heat Life™*: Up to 24 hours) Note: The amount and weight of wood contained per cubic foot of firebox volume can vary from 10 to 25 lbs. per cubic foot depending on type of wood, moisture content, packing density and other factors.

Stove Dimensions:

Height: 27 1/2" (69.8cm)
Width: 25 1/2" (64.7cm)
Depth: 21 7/8" (55.5cm)
Weight: 464 lbs. (210 kg)

Connector Size: 6" (152 mm) diameter
Metal Chimney: 6" (152 mm) inside diameter
Masonry Chimney: 6" (152 mm) inside diameter (round flue), 8" x 8" (203 x 203 mm) (square flue)

Crate Dimensions: H-39" W-29" L-36" or 99x73.7x 91.5cm (add 4" or 10.2cm for pallet).

Optional Equipment:

Outside Air Kit	90-53300
Blower	90-57210
Spark Screen	90-69300
Rear Heat Shield	90-68300

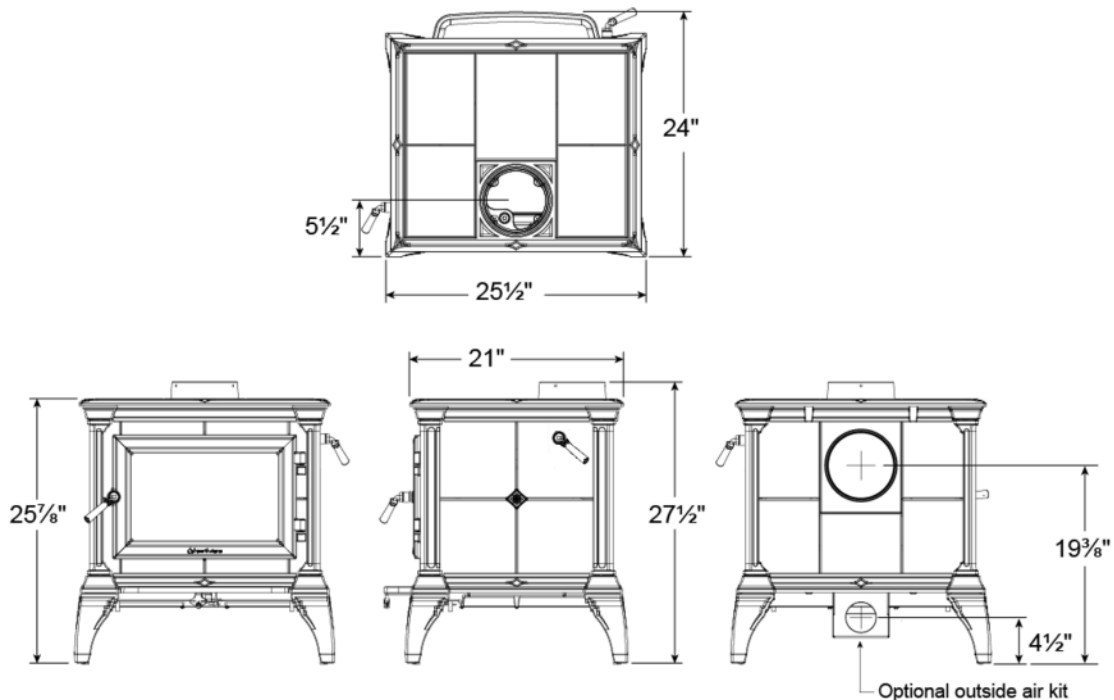

Figure 1 – Castleton 8031 Dimensions

INSTALLATION

UNPACKING

Hearthstone packages your Castleton 8031 woodstove with the greatest care so that it ships safely. Under certain circumstances, however, damage may occur during transit and handling. When you receive the Castleton 8031, carefully unpack and inspect the stove and all accompanying parts. Ensure that all parts are included in the ash pan. If any parts are damaged or missing, please contact your authorized Hearthstone dealer immediately.

The catalysts are secured in the stove with packaging material for shipping. This material does not need to be removed and will burn off during your first fire.

PACK LIST

Castleton 8031 Woodstove
Owner's Manual Wood Handles, Screws, And Washers (See Illustration 1 on page 8 for installation)
Canadian Handle Kit 90-71310 (Where Applicable)

The door and bypass handles are shipped inside the stove to protect them during shipping and installation. It is best not to install them until after stove is moved into its final location. **For US installations**, the handles can be installed directly on the stove. **For Canadian installations**, use the removable Canadian Handle Kit 90-71310 supplied with stove and DO NOT permanently install handles directly to stove.

The label is attached by a cable to the bottom of the stove. Take care when lifting the stove not to damage the label or cable. After final positioning of the stove, the label may be stored in the holding clip on the bottom shield of the stove.

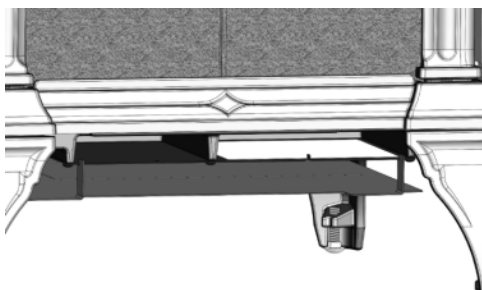

Figure 2 - Label Location

Installing Your Stove

Choose a place to install your Castleton 8031 woodstove. Consider the location of your stove for optimum heating efficiency. In general, it is better to place your stove in a main living area, rather than in a basement or other confined space.

Inspect this location to make sure that the stove and stovepipes will have the required clearance from combustible materials that are near the stove. Combustibles include walls, floor, ceiling, and chimney chase. You must carefully consider the clearances to all of these combustibles before actually connecting your stove.

If the floor is made of combustible material, then a non-combustible floor protector is required between the floor and the stove. An example of a non-combustible floor protector is a hearth constructed with a continuous layer of tile, brick, slate, glass or another non-combustible facing. There is no R-value requirement.

If you lift your stove from underneath, **be sure to temporarily remove the lower heat shield to avoid damage. Once the stove is installed in position, replace the lower heat shield.** The lower heat shield is required for safe operation.

If you use a rear connector pipe, ensure it is listed with Underwriter's Laboratories. Check the listing of your pipe with UL for the correct clearances.

The diagrams in this manual represent typical installations, but are specific to the Simpson Dura-Vent DVL brand.

Clearances to NFPA Code 211 Protected Surfaces

You can reduce the clearances to combustible surfaces by using any National Fire Protection Agency (NFPA) approved wall protection system with additional approval of the regulatory authority having jurisdiction in your area.. Please refer to NFPA Code 211 for specifications and complete details. You can obtain this information directly from the NFPA

National Fire Protection Agency

Batterymarch Park
Quincy, MA 02269
1-800-344-3555
1-617-770-3000
www.nfpa.org

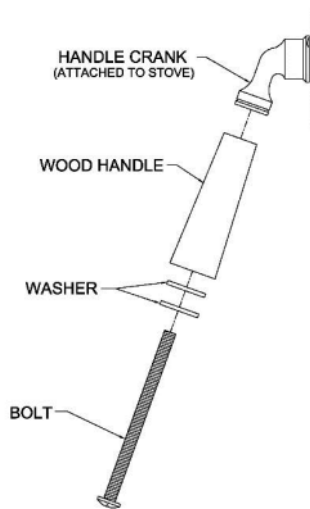
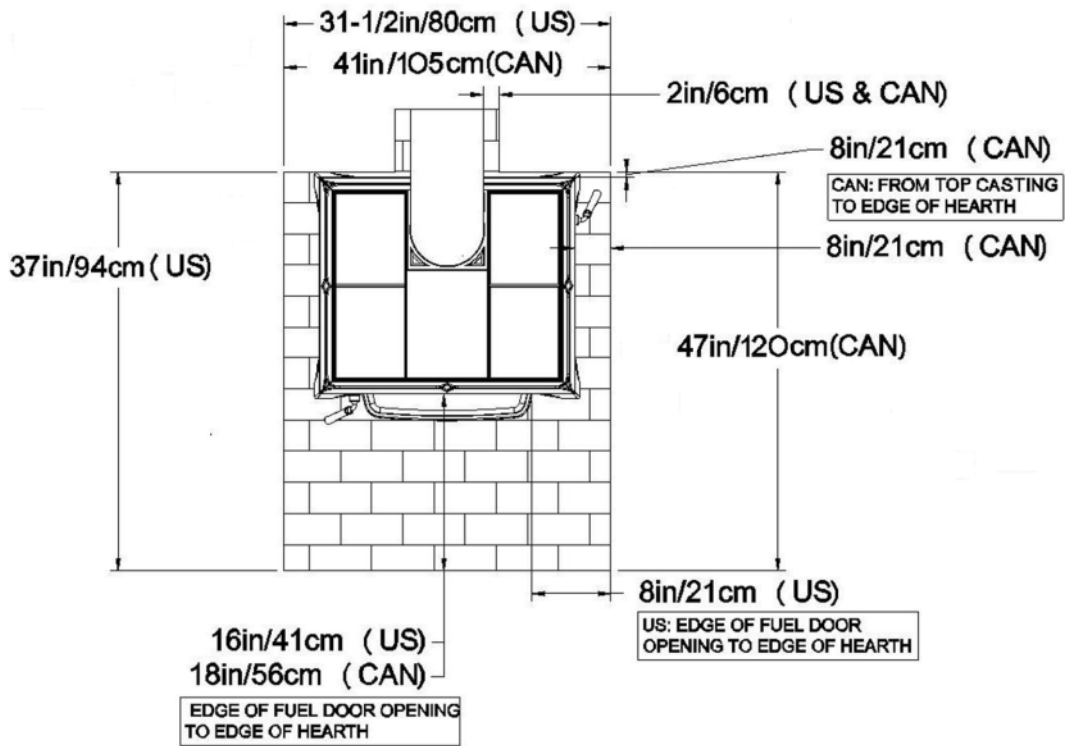

Illustration 1 – Handle Installation (US)

HEARTH REQUIREMENTS & FLOOR PROTECTION

Ensure you protect combustible flooring with a covering of noncombustible material. The Castleton 8031 does not require an insulated hearth pad. The minimum floor protection must be met under the stove and extend beyond the stove as follows:

The minimum floor protection for US installations is 37in x 31-1/2in.
 The minimum floor protection for installations in Canada is 47in x 41in.



COMBUSTIBLE SURFACE REQUIRED CLEARANCES

Note: Dimensions shown in the following figures are from the top casting of the stove unless otherwise indicated.

It is very important to follow minimum clearances for chimney connectors to combustibles such as walls and ceilings when installing the stove near combustible surfaces.

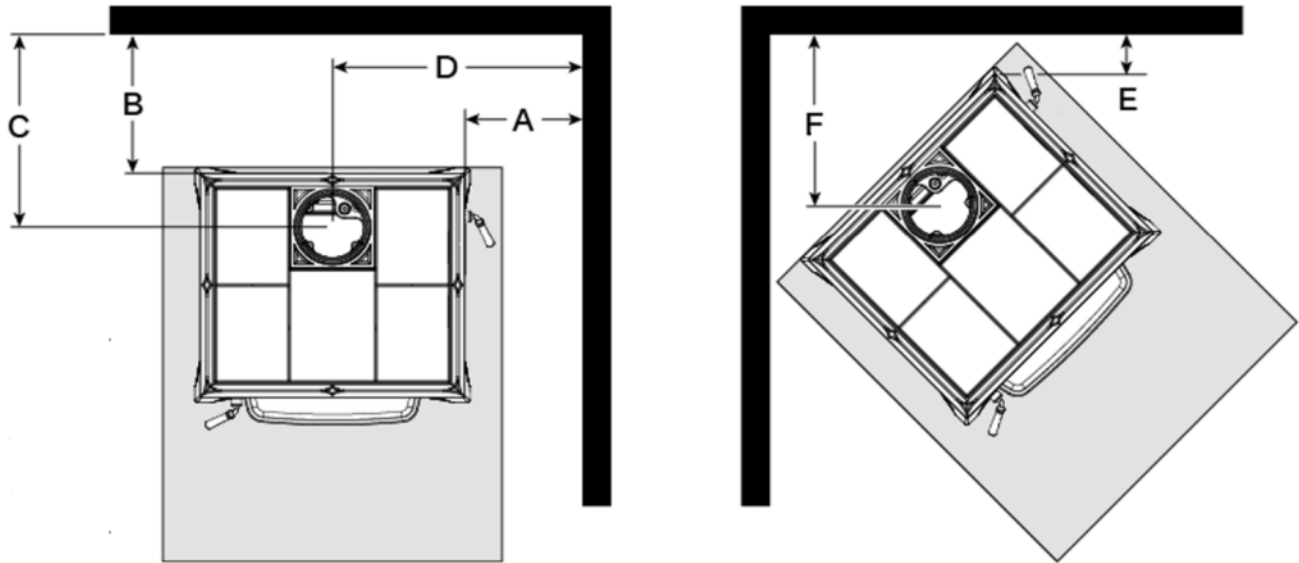

Figure 4 – Clearance to Combustibles

Clearances	Parallel				Corner	Corner
	A	B	C	D	E	F
Single wall Connector – No Rear Heat Shield	17"-44cm	15"-39cm	20"-51cm	29.25"-75cm	8"-21cm	20.5"-53cm
Single Wall Connector – With Rear Heat Shield	17"-44cm	9"-23cm	14"-36cm	29.25"-75cm	8"-21cm	20.5"-53cm
Double Wall Connector – No Rear Heat Shield	17"-44cm	15"-39cm	20"-51cm	29.25"-75cm	8"-21cm	20.5"-53cm
Double Wall Connector – With Rear Heat Shield	17"-44cm	8"-21cm	13"-33cm	29.25"-75cm	8"-21cm	20.5"-53cm
Alcove W/Single Wall Conn – No Rear Heat Shield	17"-44cm	16"-41cm	21"-54cm	29.25"-75cm	8"-21cm	20.5"-53cm
Alcove W/Single Wall Conn – With Rear Heat Shield	17"-44cm	16"-41cm	21"-54cm	29.25"-75cm	8"-21cm	20.5"-53cm
Alcove W/DbI Wall Conn – No Rear Heat Shield	17"-44cm	16"-41cm	21"-54cm	29.25"-75cm	8"-21cm	20.5"-53cm
Alcove W/DbI Wall Conn – With Rear Heat Shield	17"-44cm	16"-41cm	21"-54cm	29.25"-75cm	8"-21cm	20.5"-53cm

Alcove Clearances (inches)	Unprotected Surfaces	Protected Surfaces (NFPA-211)
Minimum alcove width	59" – 149.9cm	See NFPA-211
Maximum alcove depth	52" – 132.0cm	See NFPA-211
Min. Alcove ceiling from floor with single wall connector	60" – 152.4cm	See NFPA-211
Min. Alcove ceiling from floor with double wall connector	60" – 152.4cm	See NFPA-211

FOR REAR HEAT SHIELD, USE KIT #90-68300

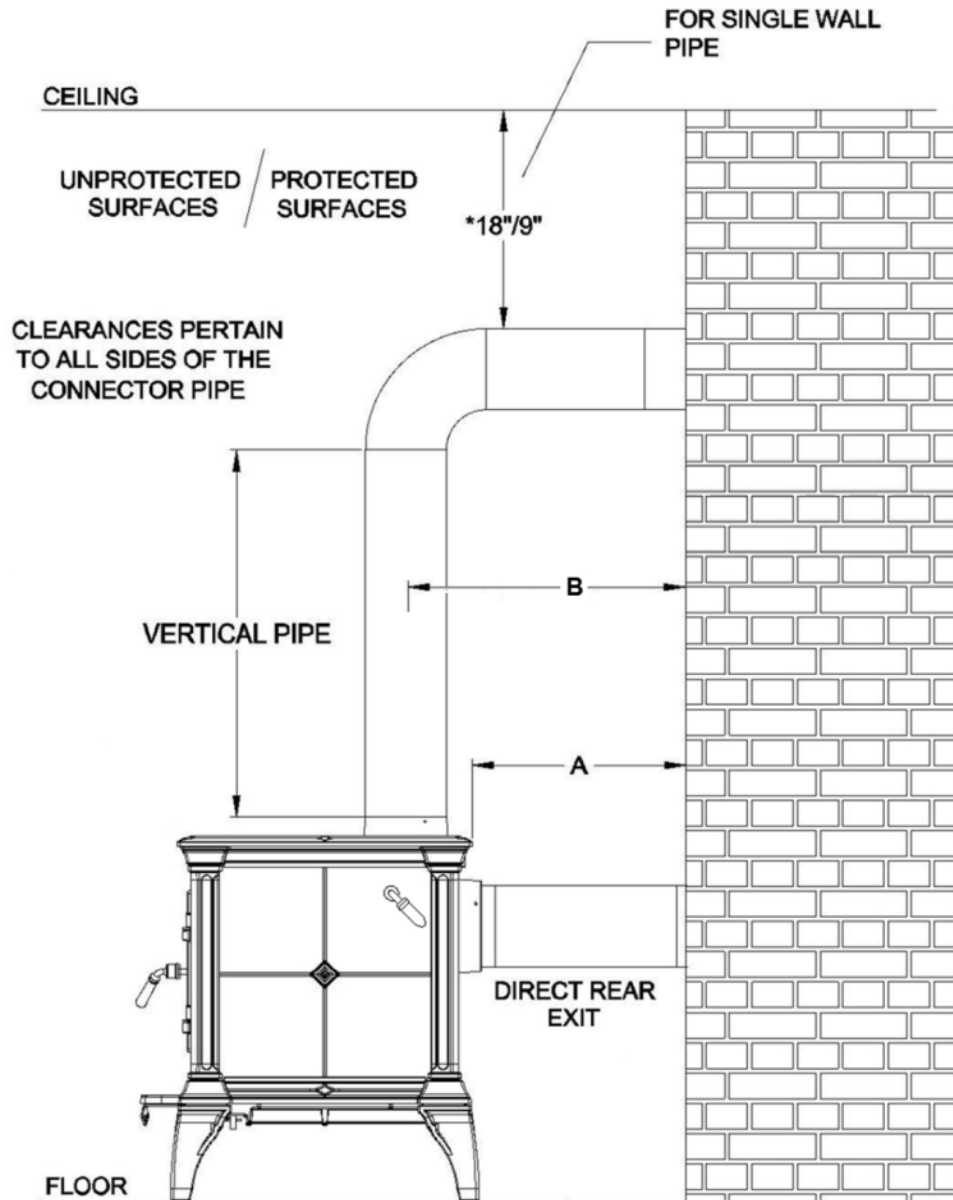

Figure 5 Chimney Connector Clearances

Through the wall top flue or direct rear exit	Single Wall Pipe		Double Wall Pipe	
	With Heat Shield**	Without Heat Shield**	With Heat Shield**	Without Heat Shield**
A	11" (27.94cm)	17" (43.2cm)	10" (25.4cm)	17" (43.2cm)
B	16" (40.6cm)	22" (55.9cm)	15" (38.1cm)	22" (55.9cm)

*For double wall pipe clearance to ceiling, refer to pipe manufacturer specifications.

** Rear Heatshield, kit #90-68300

See Parallel Clearance to Combustibles for clearances to the sides of the stove.

CHIMNEY CONNECTOR SYSTEMS AND CLEARANCES FROM COMBUSTIBLE WALLS FOR RESIDENTIAL HEATING APPLIANCES

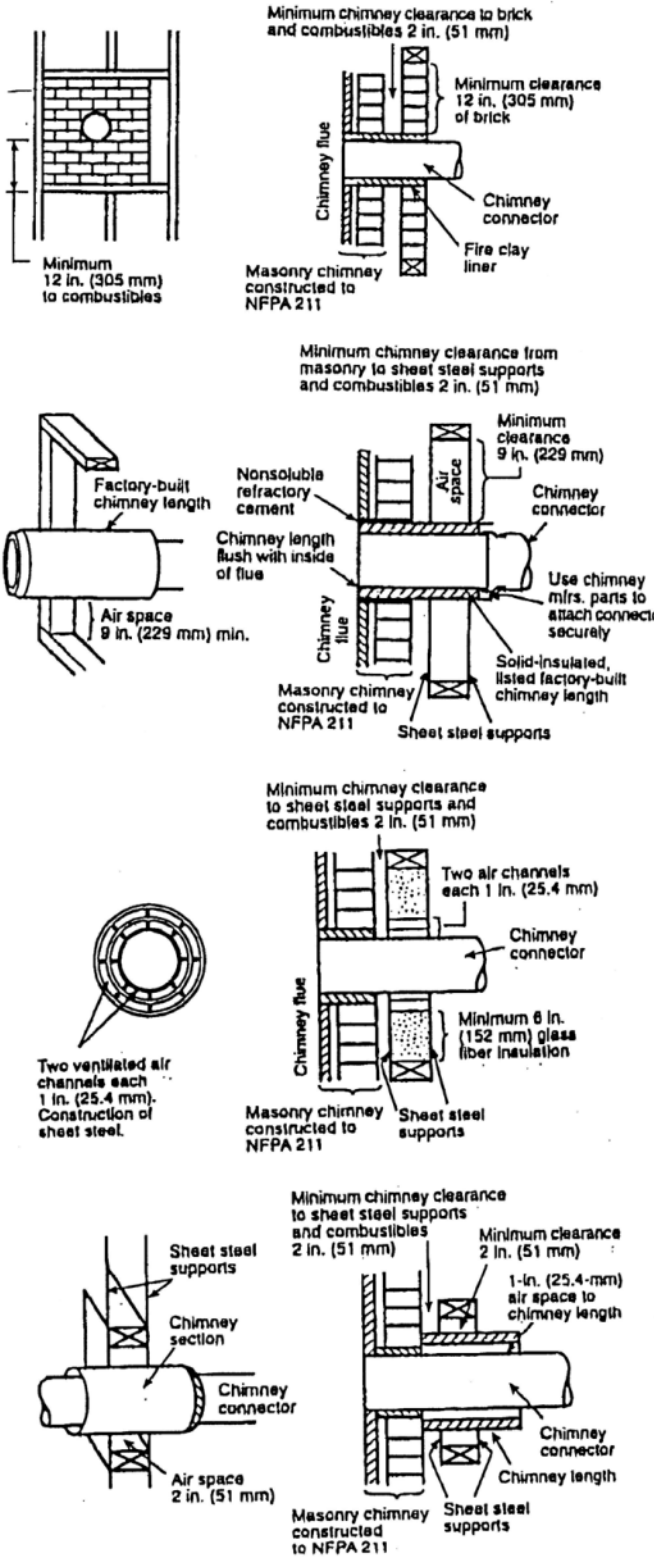

- A. Minimum 3.5in thick brick masonry all framed into combustible wall with a minimum of 12in. brick separation from clay liner to combustibles. The fire clay liner shall run from outer surface of brick wall to, but not beyond, the inner surface of chimney flue liner and shall be firmly cemented in place.
- B. Solid-insulated, listed factory-built chimney length of the same inside diameter as the chimney connector and having 1in. or more of insulation with a minimum 9in. air space between the outer wall of the chimney length and combustibles.
- C. Sheet steel chimney connector, minimum 24 gauge in thickness, with a ventilated thimble, minimum 24 gauge in thickness, having two 1in. air channels, separated from combustibles by a minimum of 6in of glass fiber insulation. Opening shall be covered, and thimble supported with a sheet steel support, minimum 24 gauge in thickness.
- D. Solid insulated, listed factory-built chimney length with an inside diameter 2in. larger than the chimney connector and having 1in. or more of insulation, serving as a pass-through for a single wall sheet steel chimney connector of minimum 24 gauge thickness, with a minimum 2in. air space between the outer wall of chimney section and combustibles. Minimum length of chimney section shall be 12in. chimney section spaced 1in. away from connector using sheet steel support plates on both ends of chimney section. Opening shall be covered, and chimney section supported on both sides with sheet steel supports securely fastened to wall surfaces of minimum 24-gauge thickness. Fasteners used to secure chimney section shall not penetrate chimney flue liner.

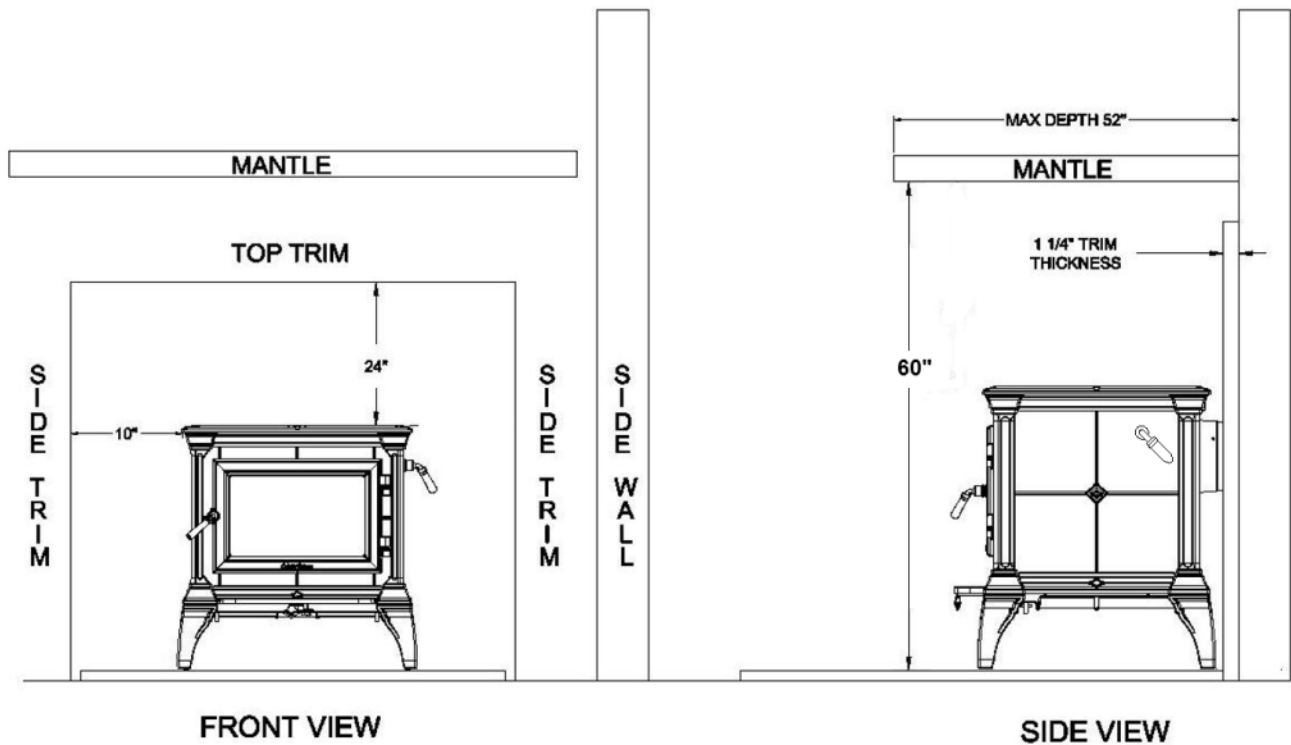

Figure 6 Trim and Mantle Clearances

OUTSIDE AIR SUPPLY

(Optional Kit #90-53300)

You can connect an outside air source directly to this stove using an optional outside air kit. The advantage of providing outside air directly to the stove is that the air used by the stove for combustion is taken from outside the residence rather than from within the room where the stove is located.

The outside air kit for this stove allows for the direct connection of the stove's air intake to a minimum 3" (76 mm) diameter duct (supplied by others)* which leads to the outside of the house. When considering placement of the duct from the outside of the house to the hearth, keep in mind the need to avoid structural members of the house. The outside air kit attaches to the underside of the stove. Refer to the instructions provided with the kit for installation.

*An adaptor for 4" duct is available if needed. KIT #90-53308

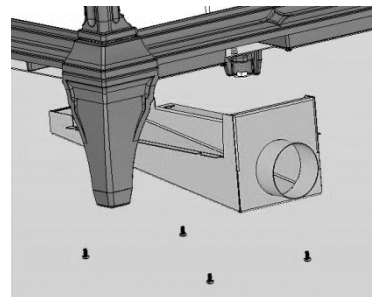

Figure 7 – Outside Air Kit Detail

The International Residential Code (IRC) does not allow the outside air duct to terminate higher than the appliance. Some building officials restrict vertical rise in the duct's termination. Hearthstone recommends the termination be at the same level, or lower than the air intake on the stove.

Locate the termination of the duct on the outside wall of the home in such a manner to avoid the possibility of obstruction by snow, leaves or other material. Screen the termination using 1/4" x 1/4" mesh rodent screen and cover it with a rain/wind proof hood (flex pipe, outside termination, mesh, and hood supplied by others) Contact your dealer for availability.

VENTING COMPONENTS & CONFIGURATION REQUIREMENTS

- **DO NOT CONNECT THIS UNIT TO A CHIMNEY FLUE USED BY ANOTHER APPLIANCE**
- Single wall connector that is at least 24 MSG or 25 MSG blued steel stovepipe.
- Double wall connector (Rear pipe) which is used with a listed, factory-built "Type HT" chimney or with a masonry chimney to reduce clearances, is available from several manufacturers, your dealer can help you choose. Some air insulated connector pipe models available are Simpson Dura Vent DVL and Metalbestos DS. Security, GSW and Ameritec also have acceptable Rear connector pipe.
- When used in a mobile home, a spark arrester is required. (See page 18)
- The chimney connector cannot pass through a floor or ceiling, nor any attic or roof space, closet or similar concealed space. Where venting requires passage through a wall or partition of combustible construction, the installation must conform to NFPA Code 211 or CAN/CSA - B365.
- It is very important to follow minimum clearances for chimney connectors to combustibles such as walls and ceilings when installing the stove. Typical chimney connector clearances are outlined below. The single wall clearances are generic; the double wall clearances shown are specifically for Simpson DuraVent DVL and may vary with other brands. **Check the specifications from the manufacturer of your connector.**

COMPONENTS OF A VENTING SYSTEM

The complete venting system consists of several components: chimney connector, wall thimble, wall pass-through, chimney, and liner. It is *absolutely necessary* that you install all of these components and maintain the clearances to combustibles discussed earlier to ensure a safe stove installation. Failure to follow these instructions and specified components or using make-shift compromises can result in fire, property damage, bodily injury, and even death. Be sure to follow the manufacturer's instructions to maintain an effective vapor barrier at the location where the chimney or other component penetrates the exterior of the structure.

To protect against the possibility of a house fire, you *must properly install and constantly maintain the venting system in good condition*. Be sure to inspect

the chimney connector and keep it clean. Upon inspection, immediately replace rusted, cracked, or broken components.

- The *chimney connector* is the stovepipe from the woodstove to the chimney. The chimney connector stovepipe is 6" (152 mm) diameter, 24 MSG or 25 MSG blued steel connector pipe. *Do not use aluminum or galvanized steel pipe* - they cannot withstand the extreme temperatures of a wood fire.
- The *thimble* is a manufactured (or site-constructed) device installed in combustible walls through which the chimney connector passes to the chimney. It keeps the walls from igniting. You must use a wall thimble when installing a chimney connector through a combustible wall to the chimney.
- A *wall pass-through* (or chimney support package) also keeps the walls from igniting. You must use one when connecting through a wall or ceiling to a prefabricated chimney.
- Only install this stove to a *lined masonry chimney* or an *approved high temperature prefabricated residential* type building heating appliance chimney. *Do not* connect this stove to a chimney serving another appliance; you will compromise the safe operation of both the wood stove and the connected appliance.
- A *liner* is the UL 1777 or ULC S635 (for factory built fireplace or masonry) chimney.

You must connect your stove to a chimney comparable to those recommended in this manual. *Do not use stovepipe as a chimney*. Use stovepipe for freestanding installations only to connect the stove to a proper chimney.

- **WARNING: DO NOT CONNECT THIS APPLIANCE TO ANY AIR DISTRIBUTION DUCT OR SYSTEM.**

INSTALLING A VENTING SYSTEM

Attach stovepipe sections to the flue collar and to each other with the crimped end toward the stove. If creosote builds up, this allows the creosote to run into the stove and not on the outside of the stovepipe or onto the stove.

Secure all joints, including attaching the stovepipe to the stove's flue collar, with three sheet metal screws. Install #10 x 1/2" (3 mm x 13 mm) sheet metal screws into the holes pre-drilled in the flue collar. Disregarding the screws can cause joints to

separate from the vibrations that result from a creosote chimney fire.

You can simplify connecting stovepipe by using additional accessories such as telescoping pipes, slip-connectors or clean-out tees. These accessories ease the periodic inspection of your chimney, as well as allow you to dismantle the stovepipe easily (without moving the stove).

Install the stove as close as practical to the chimney, while maintaining all proper clearances. Install stovepipe that is as short and as straight as possible. Horizontal runs of stovepipe must always rise away from the stove at a minimum of 1/4" per foot (21mm/m).

We do not recommend long runs of stovepipe to increase heat dispersal. Longer lengths of stovepipe, or more connecting elbows, than necessary increase the chances of draft resistance and the accumulation of creosote buildup.

In general, you do not need to install a stovepipe damper with the Castleton 8031. Some installations, however, could benefit from a stovepipe damper, such as a tall chimney which can create a higher than normal draft. In such cases, a damper can help regulate the draft. The Castleton 8031 requires a draft between 0.06" and 0.1" WC. For drafts above 0.1" WC, install a stovepipe damper. Check the draft at stove installation time.

Remember, the NFPA recommends minimum clearances for chimney connectors to combustibles such as walls and ceilings. Once the stove is installed at safe distances from these combustible surfaces, it is also important to maintain these connector clearances for the remainder of the installation.

CONNECTING THE STOVE TO A CHIMNEY

You can install your Castleton 8031 to a prefabricated metal chimney, or to a masonry chimney.

This room heater must be connected to (1) a listed Type HT (2100° F) chimney per UL 103 or ULC S629, or (2) a code-approved masonry chimney with a flue liner. The chimney size should not be less than the flue collar, or more than three times greater than the cross-sectional area of the flue collar.

We recommend installing a cleanout tee where possible to simplify chimney cleaning and maintenance.

Connecting to a Prefabricated Metal Chimney

There are two ways to install a prefabricated metal chimney:

- An *interior* installation where the chimney passes inside the residence through the ceiling and roof.
- An *exterior* installation where the chimney passes through the wall behind the stove then up the outside of the residence.

Whenever possible, choose an interior chimney. An interior chimney heats up quickly and retains its heat; thus promotes a better draft and discourages the formation of creosote. An exterior chimney does not benefit from the warmth of the building, so it typically operates at lower flue temperatures than an interior chimney and may experience increased creosote accumulation.

When connecting the Castleton 8031 to a prefabricated metal chimney, you must follow, precisely, the manufacturer's installation instructions. Use only Type HT (2100° F), prefabricated metal chimneys listed per UL 103 or ULC S629 standards.

Ensure the size of the prefabricated chimney's flue is appropriate for the Castleton 8031. The Castleton 8031 requires a 6" (152 mm) inside diameter flue for new installations. A 6" diameter flue provides adequate draft and performance. You can use an 8" (203 mm) diameter existing flue with a reducer. An oversized flue contributes to creosote accumulation. (In this case, bigger is NOT better.)

When purchasing a prefabricated chimney to install with your stove, Ensure you also purchase from the same manufacturer the wall pass-through (or ceiling support package), "T" section package, fire-stops (when needed), insulation shield, roof flashing, chimney cap, and any other required accessories. Follow the manufacturer's instructions when installing the chimney and accessories. In addition, ensure you maintain all manufacturers' recommendations for the proper clearances to the chimney.

Connection to a Masonry Chimney

Consider two primary elements when connecting your stove to a masonry chimney: the chimney itself and the thimble where the stovepipe connects to the chimney. **Use only code approved masonry chimneys containing a proper flue liner.**

Before connecting to a masonry chimney, hire a professional to examine the chimney for cracks, loose mortar, and other signs of deterioration and blockage. If the chimney needs repair, complete

them before installing and using your stove. Do not install your stove until the chimney is safe for use.

Ensure the chimney's cleanout is complete and working properly. To avoid a loss of draft, the cleanout door must close completely and provide a tight seal. If the cleanout door leaks, the chimney will cool, your stove will perform poorly, and creosote can form.

Ensure the size of the chimney's flue is appropriate for this stove and that it is not too large. Use a masonry chimney with a maximum 6" Diameter or 8" x 8" (203 mm x 203 mm) tile size for best results. An oversized flue contributes to the accumulation of creosote.

Use the following checklist to ensure that your masonry chimney meets these minimum requirements:

MASONRY CHIMNEY WALL CONSTRUCTION:

- Mortared brick or modular block at least 4" (102 mm) thick – must use liner
- A mortared rubble or stone wall – must use liner

FLUE LINER OPTIONS:

- Tile - minimum wall thickness of 5/8" (16 mm), installed with refractory mortar, and with at least 1" (25 mm) air space around the liner
- Stainless steel - UL listed 6" diameter, insulated or wrapped liner, or the space around the liner

filled with vermiculite or suitable material (these keep the liner warmer for better performance)

- Ensure any equivalent flue liner is a listed chimney liner system meeting type HT requirements or other approved material.

INTERIOR CHIMNEY REQUIREMENTS:

- Must have at least 2" (51 mm) clearance to combustible materials
- Must install fire stops at the spaces where the chimney passes through floors and/or ceiling
- Any insulation material must be at least 2" (51 mm) from the chimney

EXTERIOR CHIMNEY REQUIREMENTS:

- At least 1" (25 mm) clearance to combustible materials

CHIMNEY HEIGHT REQUIREMENTS (SEE FIGURE 9):

- At least 3 feet (0.9 m) higher than the highest part of the roof opening through which it passes.
- At least 2 feet (0.6 m) higher than any part of the roof within 10 feet (3 m) measured horizontally from the top of the chimney.

The recommended minimum chimney height is 10 feet (3 m) off the floor. The recommended maximum chimney height is 30 feet (9m). The Castleton 8031 requires a draft between 0.06" and 0.1" water column. Ensure your chimney is long enough to provide the minimum draft, and use a damper if your installation has a required chimney height that provides too much draft.

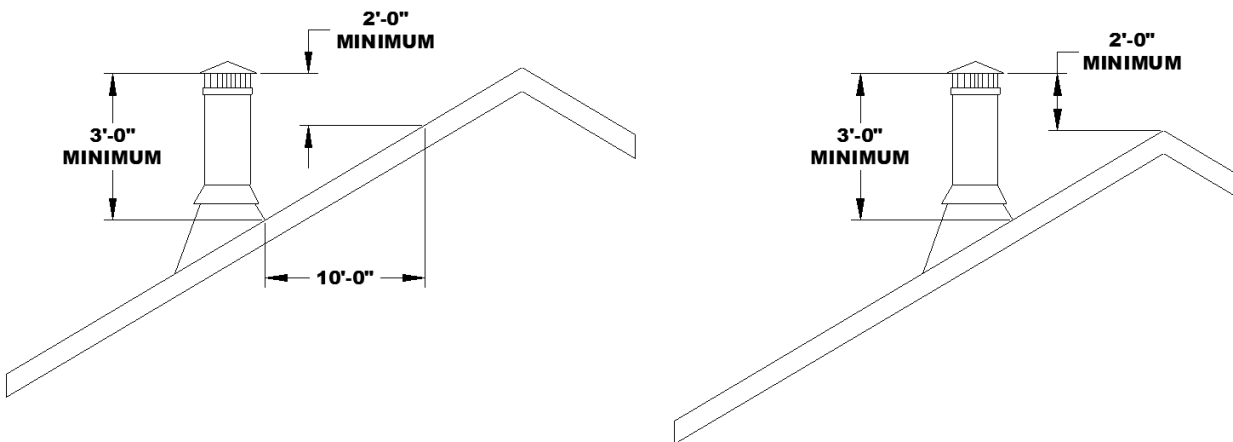
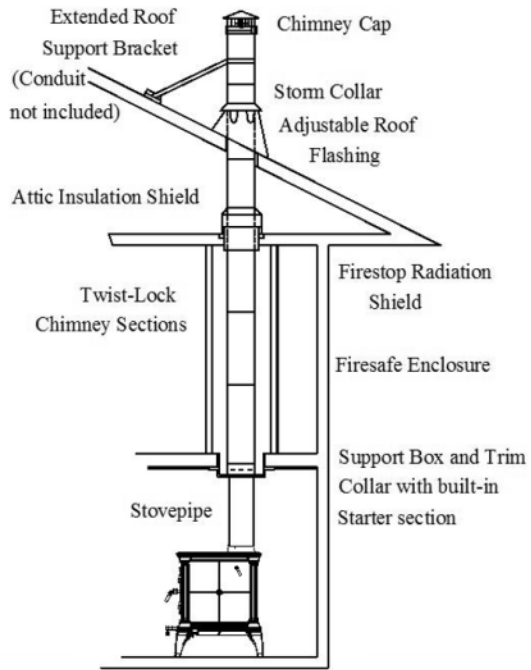
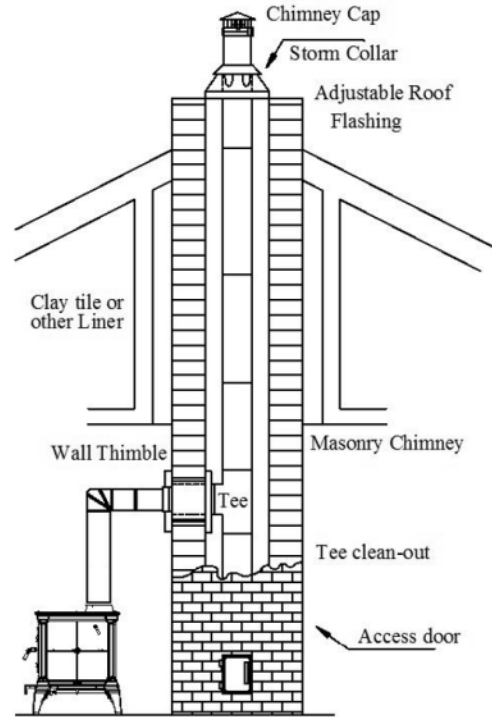

Figure 8 – Chimney Height Requirements



Two story house installation with attic.



Chimney pipe through Clay tile or other Lined Masonry Chimney

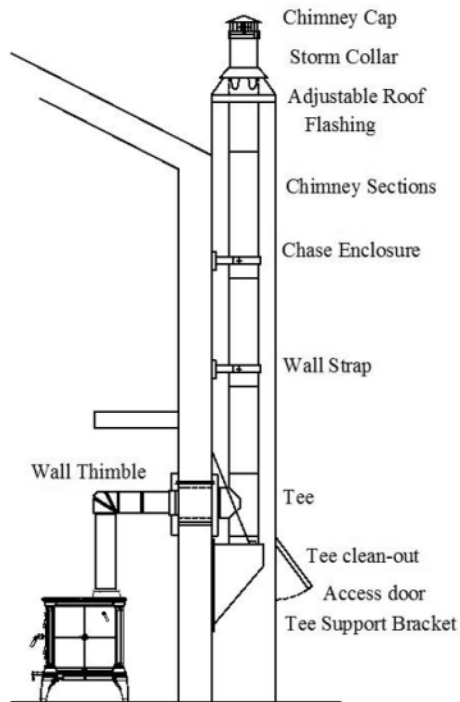

Chimney through outer wall with enclosed chase. Chimney is supported by Tee Support Bracket.

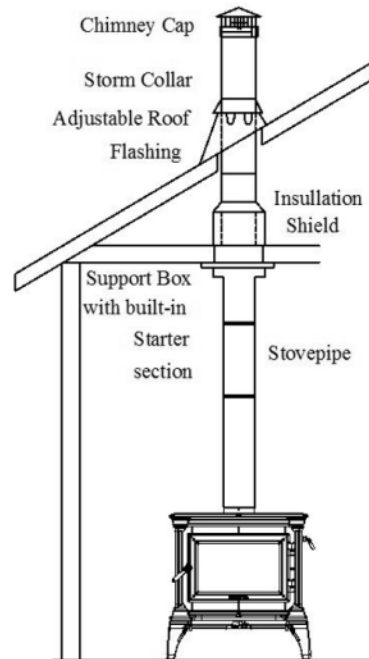

One story house installation with attic. Chimney is supported by Ceiling.

Figure 9 – Typical Chimney Configuration

INSTALLING IN A MOBILE HOME

Follow these special requirements for installing your stove in a mobile home.

- Install the stove in accordance with 24 CFR, Part 3280 (HUD)
- An outside air kit must be used in all mobile home installations. See page 12 for details.
- Permanently attach the stove to your mobile home's floor. Use the shipping clips that came with the stove and fasteners long enough to attach securely to the subfloor. (The clips and fastener heads may be painted to minimize visibility).

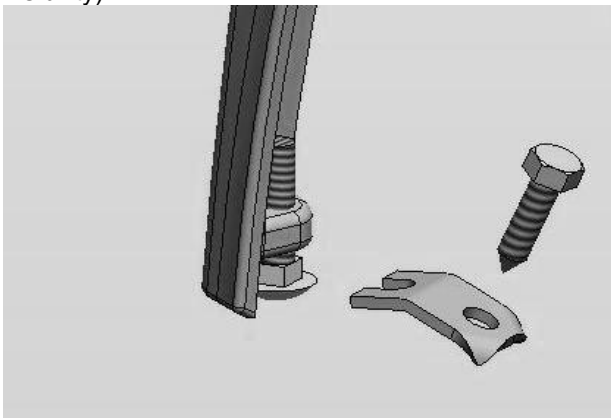

Figure 10 - Lock Down Detail

- Install a Mobile Home Chimney & Connector Kit conforming to US/UL103 or CAN/ULC-S629, Standard for Factory-Built Chimneys. The system must be removable for transportation and meet all applicable local and federal guidelines for termination height.

Each kit must include:

Stainless spark arrester cap, storm collar, Adjustable vented flashing – 0/12 – 6/12, Two 24" chimney pipes, 24" support box with built-in starter section and trim.

- Failure to follow these instructions and specified components or using make-shift compromises can result in fire, property damage, bodily injury, and even death.
- **WARNING: DO NOT INSTALL IN A SLEEPING ROOM IN A MOBILE HOME.**
- **CAUTION: MAINTAIN THE STRUCTURAL INTEGRITY OF THE MOBILE HOME WALLS, FLOOR, CEILING, AND ROOF WHEN INSTALLING AND USING YOUR STOVE.**
- **Burning any fuel other than wood in this unit could generate dangerous levels of carbon monoxide within the living space.**

- **THE FRONT DOOR MUST REMAIN CLOSED WHEN IN OPERATION EXCEPT FOR START UP AND LOADING.** Leaving the door open during use could cause any smoke or fire detectors in the home to be set off or a fire could escape the firebox and start the room on fire.
- **If this unit is installed in a mobile home, care must be taken to ensure adequate air is available. If not enough air is available it could starve the room of all the oxygen. (See page 27 for more details)**
- **CAUTION: REMOVE THE CHIMNEY WHEN TRANSPORTING THE MOBILE HOME!**
- Be sure to follow the manufacturer's instructions to maintain an effective vapor barrier at the location where the chimney of other component penetrates the exterior of the structure.

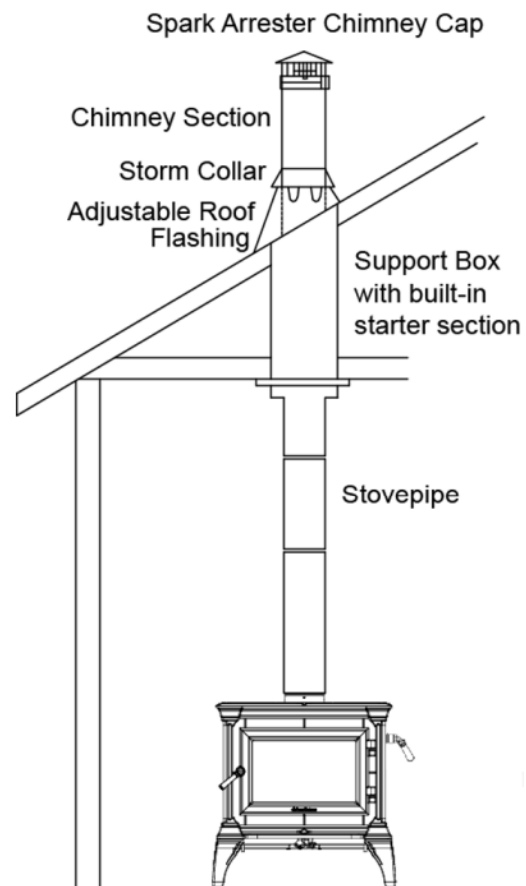

Mobile home installation.
One story house installation with attic.
Chimney is supported by Ceiling.

Figure 11 – Mobile Home Installation

OPERATION

Once your Castleton 8031 is installed, you are ready to light a fire.

Every installation, season's firewood, and operator's technique varies. Learn how to use your stove most efficiently for your installation. We can give you the basic principles, but only you can ensure maximizing the potential of your stove while also operating it safely.

- **WARNING: HOT WHILE IN OPERATION! KEEP CHILDREN, PETS, CLOTHING AND FURNITURE AWAY. CONTACT MAY CAUSE SKIN BURNS.**

Read this entire chapter before lighting your first fire. It explains the controls and features of your wood stove, how to choose firewood, and how to use your stove on a daily basis.

CONTROLS AND FEATURES

Before lighting any fires, become familiar with the location and operation of your stove's controls and features and learn how to use them (See Figure 12). For your own safety, do not modify these features in any way. We recommend you use fireplace gloves when the stove is in operation and hot.

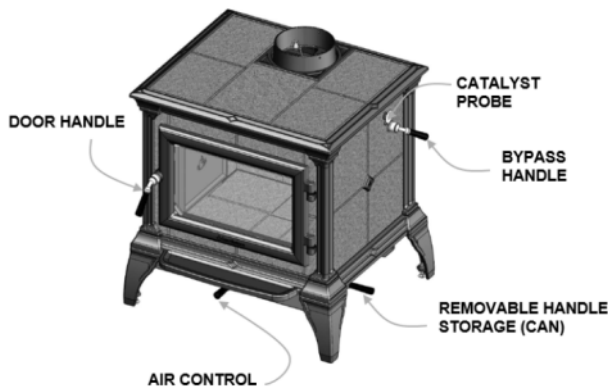

Figure 8 - Controls & Features

FRONT DOOR HANDLE: The firebox door allows you to load wood into your stove; a wood handle operates the door. To open the door, pull up on the handle and swing the door away from the stove. To latch the door, push the door tightly towards the firebox then continue to push the handle in and down until it latches shut. Gently pull on the door handle to make sure it is properly latched.

PRIMARY AIR CONTROL: The primary air control lever is located under the ash lip. The primary air control allows you to regulate the amount of air

entering the firebox. Generally, the more air allowed into the firebox, the faster the rate of burn and the higher the heat output; conversely, less air creates a slower burn, with lower heat output. For maximum airflow, move the lever left as far as possible; move the lever right as far as possible for minimum airflow (does not close completely).

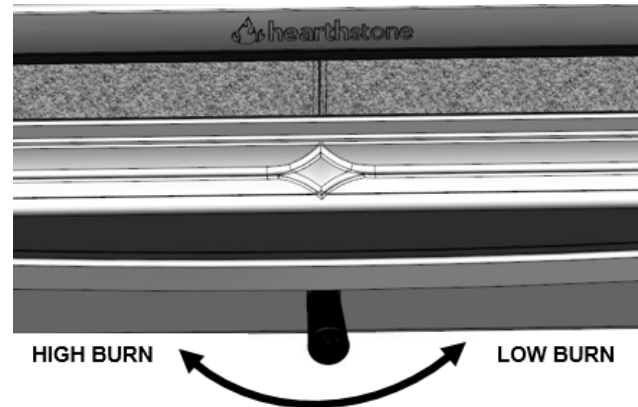

Figure 9 – Air Control

BYPASS HANDLE: The bypass handle controls the bypass door inside the stove. When the handle is pointed towards the front of the stove, the bypass door is open, and when the handle is pointed towards the rear of the stove, the bypass door is closed. The bypass door directs the flow of combustion products through or around the catalytic combustor. When the bypass handle is open, combustion products are directed around the catalytic combustor. The bypass handle should be open when first starting a fire until the catalytic combustor heats up to activation temperature, and whenever opening the front door to load the stove. When the bypass handle is closed, combustion products are directed through the catalytic combustor. The bypass handle should be closed once the catalytic combustor heats up to activation temperature, and remain closed whenever the stove is burning and in the active temperature range.

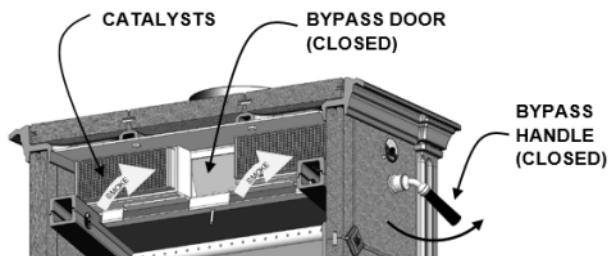

Figure 14 – Bypass Closed

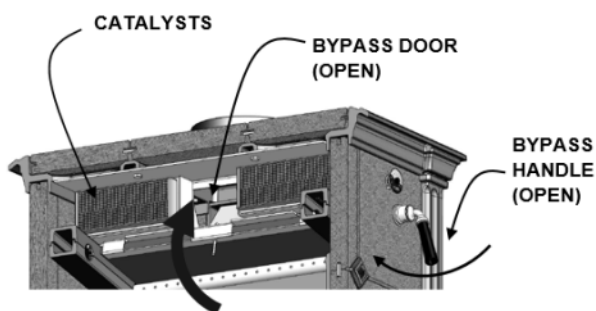

Figure 15 – Bypass Open

CATALYST PROBE: The catalyst probe monitors the downstream temperature of the catalyst, and indicates when the stove is in the active range for the catalyst. When the stove is in the “active” range, the bypass handle should be closed. When the stove is in the “Inactive” range, the bypass handle should be opened until the stove heats up. If the probe is in the “Too Hot” range, keep the door closed, fully close the air control, and allow the stove to cool down until the probe falls into the “Active” Range. Once the catalyst probe has reached the active range, heat generated from burning smoke keeps the catalyst warm and active as long as fuel remains in the stove. The Castleton 8031 typically operates in the 800 °F to 1300 °F range.



Figure 16 – Catalyst Probe

CHOOSING FIREWOOD

Burn only natural firewood (known as cordwood) in the Castleton 8031 Model 8640 Wood Heater. This stove is not designed to burn other fuels.

- **CAUTION: DO NOT USE CHEMICALS OR FLAMMABLE FLUIDS TO START THE FIRE. DO NOT USE CHARCOAL, PELLETS, COAL, ARTIFICIAL LOGS OR ANY OTHER MATERIALS AS FUEL; THEY ARE NOT SAFE. DO NOT BURN GARBAGE OR FLAMMABLE FLUIDS.**
- **THE USE OF UNAUTHORIZED FUEL SUCH AS COAL COULD PRODUCE HIGH LEVELS OF CARBON DIOXIDE IN THE LIVING SPACE. AT HIGH LEVELS CARBON DIOXIDE COULD RESULT IN PERSONAL INJURY OR DEATH.**

The quality of your firewood directly affects heat output, duration of burn and performance of your stove. Softwoods generally burn hotter and faster, while hardwoods burn longer and produce better coals. Density and moisture content are two critical factors to consider when purchasing wood for your stove.

The following is a list of some wood species and their relative BTU (British Thermal Unit) content. The higher the BTU content, the longer the burn. Firewood with higher BTUs is generally ideal for a wood stove

Wood Heat Value: Sorted By Btu Content		
Common Name	Lb/ cord	MBTU/ cord
High		
Osage Orange (Hedge)	4,728	32.9
Hickory, Shagbark	4,327	27.7
Hop Hornbeam (Ironwood)	4,267	27.3
Beech, Blue (Ironwood)	3,890	26.8
Birch, Black	3,890	26.8
Locust, Black	3,890	26.8
Hickory, Bitternut	3,832	26.7
Locust, Honey	3,832	26.7
Apple	4,100	26.5
Mulberry	3,712	25.8
Oak, White	4,012	25.7
Medium High		
Beech, European	3,757	24
Maple, Sugar	3,757	24
Oak, Red	3,757	24
Ash, White	3,689	23.6
Birch, Yellow	3,689	23.6

Medium		
Juniper, Rocky Mtn	3,150	21.8
Elm, Red	3,112	21.6
Coffee tree, Kentucky	3,112	21.6
Hackberry	3,247	20.8
Tamarack	3,247	20.8
Birch, Gray	3,179	20.3
Birch, White (Paper)	3,179	20.3
Walnut, Black	3,192	20.2
Cherry	3,120	20
Ash, Green	2,880	19.9
Cherry, Black	2,880	19.9
Elm, American	3,052	19.5
Elm, White	3,052	19.5
Sycamore	2,808	19.5
Ash, Black	2,992	19.1
Maple, Red	2,924	18.7
Fir, Douglas	2,900	18.1
Medium Low		
Boxelder	2,797	17.9
Alder, Red	2,710	17.2
Pine, Jack	2,669	17.1
Pine, Norway (Red Pine)	2,669	17.1
Pine, Pitch	2,669	17.1
Catalpa	2,360	16.4
Hemlock	2,482	15.9
Spruce, Black	2,482	15.9
Pine, Ponderosa	2,380	15.2
Low		
Aspen, American	2,290	14.7
Butternut (Walnut, White)	2,100	14.5
Spruce	2,100	14.5
Willow	2,100	14.5
Fir, Balsam	2,236	14.3
Pine, White (Eastern, Western)	2,236	14.3
Fir, Concolor (White)	2,104	14.1
Basswood (Linden)	2,108	13.8
Buckeye, Ohio	1,984	13.8
Cottonwood	2,108	13.5
Cedar, White	1,913	12.2

Moisture content also plays a key role in the performance of your stove. Wood freshly cut from a

living tree (green wood) contains a great deal of moisture. As you might expect, green wood burns poorly. You must season green wood before using it in your wood stove. To season green wood properly, split, stack, and allow it to air dry for a period of one year. Green wood may provide less than 2000 Btu per pound, whereas dry wood can provide up to 7000 Btu per pound.

Stack the firewood on skids or blocks to keep it off the ground, cover only the top of the stack. Plastic or tarps that cover the sides of the woodpile trap moisture and prevent the wood from drying. As for stacking, an old Vermonter said, "The spaces between the logs should be large enough for a mouse to get through, but not for the cat that's chasing it."

- **CAUTION: DO NOT STORE FIREWOOD WITHIN THE STOVE'S SPECIFIED CLEARANCES TO COMBUSTIBLE MATERIALS.**

BUILDING A FIRE

Once you understand the controls of your wood stove and have the appropriate firewood, you are ready to start a fire.

- **WARNING: NEVER USE GASOLINE, GASOLINE-TYPE LANTERN FUEL, KEROSENE, CHARCOAL LIGHTER FLUID, OR SIMILAR LIQUIDS TO START OR 'FRESHEN UP' A FIRE IN THIS HEATER. KEEP ALL SUCH LIQUIDS WELL AWAY FROM THE HEATER WHILE IT IS IN USE.**

BREAKING IN YOUR WOOD STOVE

It is imperative that your stove is "broken in" gradually. Soapstone must be "seasoned"; over-firing a new stove may cause soapstone to crack or may damage other stove parts. Natural moisture in the freshly quarried soapstone must be driven out slowly to minimize the "shock" to the stone of its first exposure to high firebox temperatures. In addition, the asbestos-free furnace cement must be cured slowly to ensure adequate sealing and bonding.

When you light your first fires, the woodstove will emit some smoke and fumes. This is normal "off-gassing" of the paints and oils used when manufacturing the woodstove. If you find it necessary, open a few windows to vent your room. The smoke and fumes will usually subside after 10 to 20 minutes of operation. The odor and smoke will end once the stove is "cured".

The first few fires of the season may produce other odors from impurities that exist in the area immediately surrounding the stove. Some potential impurities are cleaning solvents, paint solvents,

cigarette smoke, and soot from scented candles, pet hair, dust, adhesives, a new carpet, and new textiles. These odors will dissipate over time. You can alleviate these odors by opening a few windows or otherwise creating additional ventilation around your stove. If any odor persists, contact your dealer or an authorized service technician.

If you adhere to the operating procedures in this manual, the steel, cast iron, and soapstone components of your stove will give you many years of trouble-free use. With use, the color of the soapstone may change and small fractures may appear on the surface. These changes do not affect the function of the stove. If a panel breaks completely, it must be replaced

Avoid the following conditions that can cause the glass, soapstone, steel or cast iron pieces to break:

- Do not throw wood into the stove.
- Do not use the door as a lever to force wood into the stove.
- Do not load wood encrusted with ice into a burning stove - the thermal shock can cause damage.
- Do not use a manufactured log grate or otherwise support the fuel. Burn the fire directly on the floor of the firebox.

BUILDING A BREAK IN FIRE

- 1) Open the bypass handle. Open the front door and place five or six double sheets of tightly twisted newspaper in the center of the firebox. Arrange kindling in a crisscross pattern over the newspaper. Kindling should be approximately ten pieces, 1/2" (13 mm) in diameter and 10" to 16" (254 mm to 457 mm) long.
- 2) Fully open the primary air control by pulling the control handle fully to the left stop.
- 3) Light the paper under the kindling. Leave the door slightly ajar momentarily until the kindling has started to burn and draft begins to pull.
- 4) Close the door and allow the fire to burn. Keep the door closed while the stove is in use.
- 5) **KEEP A WATCHFUL EYE ON YOUR STOVE** to maintain a steady, low-heat fire. Your first fire should make the stove warm but **not hot to the touch**. Visible steam, or boiling moisture and hissing indicate the soapstone is too hot. At most, a few small chunks of wood should be added to the fire to reach safe break-in temperatures.
- 6) Once the stove is warm but **not hot to the touch**, close the primary air control by pushing it

fully inward toward the stove to allow the fire to die out completely.

- 7) Let the stove return to room temperature.

Your first fire and first fire each season thereafter should be built and maintained as outlined above. Your patience will be rewarded by a properly seasoned stove.

- **NOTE:** The cool flue gas temperatures present during the break-in procedure may cause rapid creosote build-up. The door glass may also get dirty. A good hot fire will clean it. We recommend a visual inspection (and cleaning if necessary) of your stovepipe and chimney once the break-in procedure is completed.

NORMAL OPERATION

BUILDING A FIRE FOR EVERYDAY USE

- 1) Open the bypass handle. Open the front door and place five or six double sheets of tightly twisted newspaper in the center of the firebox. Arrange kindling in a tee-pee configuration over the newspaper. Use approximately 10 pieces of kindling, 1/2" (13 mm) in diameter and 10" to 16" (254 mm to 406 mm) long.
- 2) Fully open the primary air control by sliding it fully to the left.
- 3) Light the paper under the kindling. Leave the front door slightly ajar momentarily until the kindling begins to burn and draft begins to pull.
- 4) Close the door and allow the fire to burn.
- 5) Once the kindling is burning, open the front door and add logs, small at first, to build the fire up. Ensure you keep the logs away from the glass in front in order for the air-wash system to work properly. Keep the front door closed while the stove is in use.

CAUTION: DO NOT BUILD THE FIRE TOO CLOSE TO THE GLASS. KEEPING THE FIRE TOWARDS THE CENTER OF THE FIRE BOX WILL KEEP COALS FROM BUILDING UP AGAINST THE GLASS DURING RELOADING.

- 6) Once the fire is burning well, and the catalyst probe indicates that the stove is in the active range, close the bypass handle. Now the combustion products are passing through the catalytic combustor, and your stove will be burning at its optimal efficiency.
- 7) After closing the bypass door, allow the stove to run on a high setting for around 20 minutes to ensure the catalytic combustor stays in the active range. This will also allow the fire to burn off any residue on the door glass from any previous low-burn fires

- 8) Use the primary air control to regulate the desired rate of burn. Pull the handle towards you for a higher burn rate, and push the handle towards the stove for a lower burn rate. The air control does not close completely.

Note: Always remember to open the bypass handle before opening the front door. When opening the front door to reload or re-arrange logs, it is advisable to open the door just a crack, pause for a moment then open the door completely. This procedure allows the firebox to clear of smoke before the door is open fully. In addition, reloading on a bed of hot, red coals reduces smoking time and brings fresh fuel up to a high temperature rapidly. During the refueling and rekindling of a cool fire, or a fire that has burned down to the charcoal phase, operate the stove at a medium to high firing rate for about 10 minutes to ensure that the catalyst reaches approximately 600 °F. Once catalyst reaches operating temperature, the bypass handle can be closed. When reloading the stove, try to keep an open path behind the Lower Primary Air Opening (LPAO). It is helpful to leave a small valley in the coal bed behind the LPAO to insure faster re-lighting.

CATALYTIC COMBUSTOR OPERATION

The Castleton 8031 uses a catalytic combustor to ensure highly clean and efficient burns. The catalytic combustor is made from a stainless steel corrugation that is coated with a catalytic material. The catalytic combustor becomes active around 500 °F (260°C), helping to burn up smoke and any remaining particles that were not fully burned in the firebox. During the startup of a cold stove, a medium to high firing rate must be maintained for about 20 minutes. This ensures that the stove, catalyst, and fuel are all stabilized and at proper operating temperatures. Even though it is possible to have gas temperatures reach 500 °F (260°C) within 2 to 3 minutes after a fire is started, if the fire is allowed to die down immediately, it may go out or the combustor may stop working. Once the stove and catalytic combustor heat up, heat generated from burning smoke keeps the catalyst warm and active as long as fuel remains in the stove. You stove will burn the cleanest and most efficiently when the catalyst is in the active range. There should be little to no visible smoke from your chimney when the catalyst is in the active zone and fully functional.

Burn Rate

This wood heater has a manufacturer-set minimum low burn rate that must not be altered.

It is against federal regulations to alter this setting or otherwise operate this wood heater in a manner inconsistent with operating instructions in this manual

LOW BURN: Move the air control lever all the way to the right. (see figure 17). This closes the air shutter to its minimum opening. A low burn rate over extended periods is not advisable as it can promote the accumulation of creosote. Inspect the venting system frequently if using low burn rates consistently.

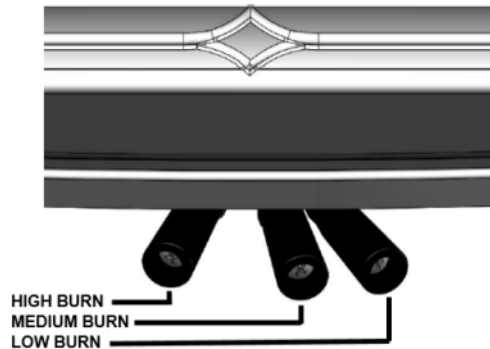

Figure 17 – Air Control Settings

MEDIUM BURN: Any setting from low to high will deliver varying rates of burn depending on the chimney setup, fuel and other local conditions. It is best to experiment to find the most comfortable setting for your situation.

HIGH BURN: Completely open the primary air control by moving it all the way to the left. Fully load the firebox with wood on a bed of hot coals or on an actively flaming fire. To minimize creosote accumulation, run the stove on high once or twice daily for 35 to 45 minutes to fully heat the stovepipe and chimney.

OPEN DOOR BURNING: Before using the optional screen (90-69300) a fire should be built to warm the stove and establish a good draft. Burning the stove with a screen will need additional makeup air. Be sure to provide adequate ventilation for the stove such as an open window. Air may be pulled through other vents and appliances in the house causing them to ice up or malfunction. Open door burning is intended for short periods only. The Castleton 8031 burns cleanest with the door closed.

CAUTION: Do not burn fuel other than cord wood in your stove.

OVER-FIRE CAUTION

Over-firing means the stove is operating at temperatures above normal temperatures reached

during High Burns outlined in the *BURN RATE* section. Carefully avoid over-firing, as it will damage the stove. Symptoms of chronic over-firing can include warped components, short burn times, a roaring sound in the stove or stovepipe, and discoloration of the stovepipe. A properly installed stove using fuel and following operating procedures as outlined in this manual should not over-fire.

Excessive draft, inappropriate fuel, and operator error can cause over-firing. Correct an over-fire situation as follows:

- **EXCESSIVE DRAFT:** Contact your local dealer to have a draft reading taken. Any draft in excess of 0.1 WC requires a damper in the stovepipe. Some installations may require more than one damper.
- **INAPPROPRIATE FUEL:** Do not burn coal; kiln dried lumber, wax logs, compressed wood, highly volatile fuel and combustible material or anything other than natural cordwood.

OPERATOR ERROR: Ensure all the gaskets are in good condition. Replace worn out or compressed gaskets. Only burn the stove with the firing and ash doors in the closed position.

If you suspect your stove is over-firing, discontinue use and contact your dealer immediately. **Damage caused by over-firing is not covered by your warranty.** Results of over-firing can include warped or burned out internal parts, cracked refractory panels, discolored or warped external parts, and damaged finish.

- **ANY SIGNS OF OVER-FIRING WILL VOID YOUR WARRANTY!**
- **THE FRONT DOOR MUST REMAIN CLOSED WHEN IN OPERATION**

REMOVAL AND DISPOSAL OF ASHES

You can leave a thin layer of ashes in the firebox if preferred. Allow fire to die down or go out completely. It is important to prevent ashes from building up around the front door opening or they will spill out, or they can pack into the gasket channel and prevent proper sealing. To remove ashes, use a fireplace shovel. Avoid removing large live coals by pushing them to the side and removing only the finer ash with a shovel.

Disposal of ashes - Ashes should be placed directly into a **metal** container with a tight fitting lid. Do not place any other items or trash into the metal container. Do not pour water into the container. Replace the container's lid and allow the ashes to cool. Never place the ash disposal container on a

combustible surface or vinyl flooring, as the container could be **hot!**

Pending disposal, place the closed ash container on a noncombustible floor or on the ground outside, well away from all combustible materials, liquid fuels, or vehicles. Retain ashes in the closed container until all coals thoroughly cool.

If the ashes are disposed of by burial in soil or otherwise locally dispersed, they should be retained in the closed container until all cinders have thoroughly cooled.

NEVER place ashes in wooden or plastic containers, in trashcans with other trash, or in paper or plastic bags, no matter how long the fire has been out. Coals within a bed of ashes can remain hot for several days once removed from the firebox.

MAINTENANCE

CATALYTIC COMBUSTOR INSPECTION AND REPLACEMENT PROCEDURES

- **WARNING: THIS WOOD HEATER CONTAINS CATALYTIC COMBUSTORS, WHICH NEED PERIODIC INSPECTION AND REPLACEMENT FOR PROPER OPERATION. IT IS AGAINST FEDERAL REGULATIONS TO OPERATE THIS WOOD HEATER IN A MANNER INCONSISTENT WITH OPERATING INSTRUCTIONS IN THIS MANUAL, OR IF THE CATALYTIC ELEMENTS ARE DEACTIVATED OR REMOVED. DO NOT OPERATE YOUR STOVE WITH THE CATALYTIC ELEMENTS REMOVED.**

It is important to periodically monitor the operation of the catalytic combustors to ensure that they are functioning properly and to determine when they need to be replaced. A non-functioning combustor will result in a loss of heating efficiency, and an increase in creosote and emissions. Following is a list of items that should be checked on a periodic basis

-Combustors should be visually inspected at least three times during the heating season to determine if physical degradation has occurred. Actual removal of the combustors is not recommended unless more detailed inspection is warranted because of decreased performance. If any of these conditions exists, refer to Catalyst Troubleshooting section of this owner's manual.

-This catalytic (or hybrid) heater is equipped with a temperature probe to monitor catalyst operation. Properly functioning combustors typically maintain temperatures in excess of 500 °F, and often reach

temperatures in excess of 1,000 °F. If catalyst temperatures are not in excess of 500 °F, refer to Catalyst Troubleshooting section of this owner's manual.

-You can get an indication of whether the catalysts are working by comparing the amount of smoke leaving the chimney when the smoke is going through the combustor and catalyst light-off has been achieved, to the amount of smoke leaving the chimney when the smoke is not routed through the combustors (bypass mode).

1. Light stove in accordance with instructions in section 3.3.5.
2. With smoke routed through the catalyst, go outside and observe the emissions leaving the chimney.
3. Engage the bypass mechanism and again observe the emissions leaving the chimney. Significantly more smoke will be seen when the exhaust is not routed through the combustor (bypass mode)

INSPECTING THE CATALYST AND REMOVING/REPLACING THE BAFFLE

1. Allow the stove and ashes to fully cool.
2. Remove the metal baffle retainer by removing the cotter pin (A) through the front air tube, and lifting the retainer upwards (B) away from the baffle.
3. Gently pull the front baffle towards the front of the stove (C), over the front tube, and out of the stove.

CAUTION - Do not force the baffle out of the stove. Gently adjust the baffle orientation until it can be removed freely from the stove.

4. The middle air tube may be removed for easier access to the catalysts, but it is not required
5. To remove the middle tube, remove the cotter pin on the right-hand side of the middle air tube, and push the tube to the right until the left end is free. Tip the left side of the tube downwards and pull the tube out of the stove
6. Use a small vacuum nozzle or soft bristled brush to remove any accumulated ash or soot on the face of the catalyst.

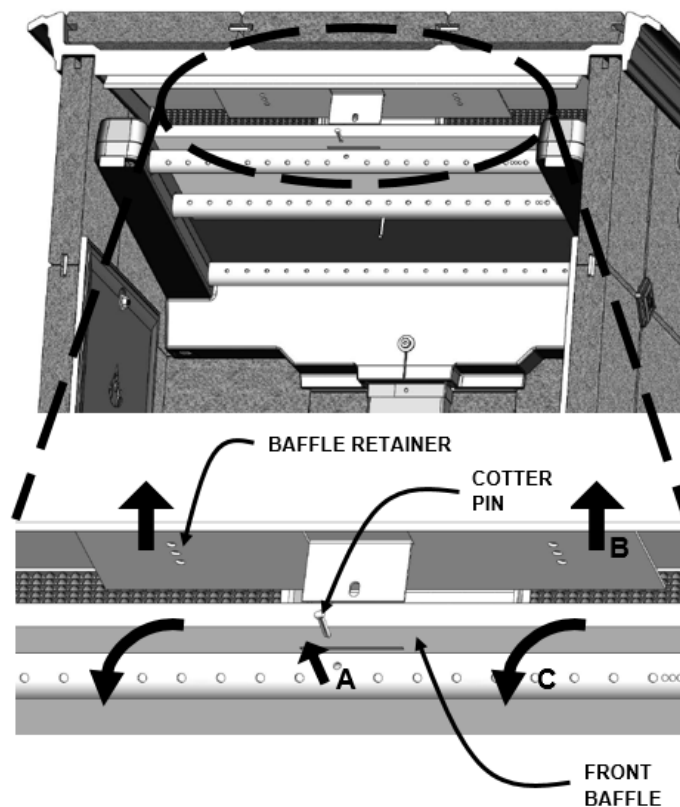

Figure 18 – Removing the Front Baffle

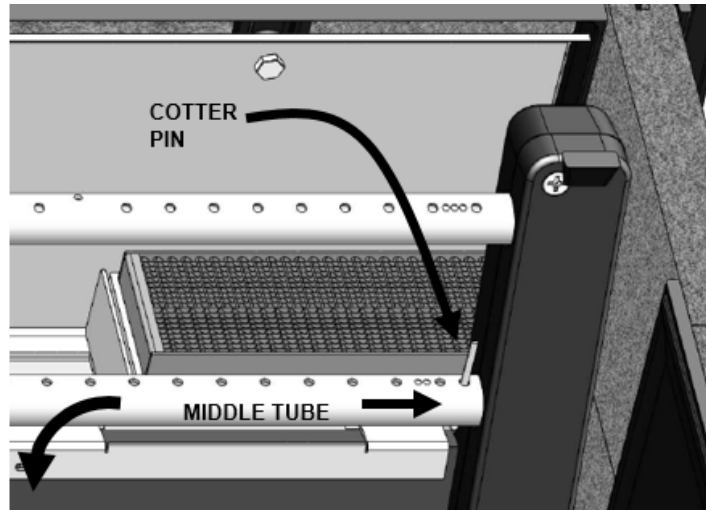

Figure 19 – Removing the Middle Air Tube

7. Inspect the catalyst for any unusual warping, corrosion, or plugged openings.
8. If any unusual conditions are found, remove the catalyst blocks – See replacing the catalysts.
9. Once the catalysts are inspected and cleaned, replace the middle air tube, baffle, and baffle retainer. Installation is the reverse of removal.

REMOVING OR REPLACING THE CATALYST

Refer to the Catalytic combustor warranty on page 35 for additional catalyst replacement information.

1. Allow the stove and ashes to fully cool.
2. Follow the procedures from “INSPECTING THE CATALYSTS AND REMOVING/REPLACING THE FRONT BAFFLE” to gain access to the catalysts.
3. Inspect the catalysts for visible damage or fly ash. If fly ash exists, gently brush the catalyst off with a narrow soft-bristle brush, or vacuum with a crevice tool.

4. If excessive fly ash exists, or if there is suspected catalyst performance issues, fully remove the catalysts by gently pulling the catalysts outwards towards the front of the stove. It may be necessary to gently rock the catalysts from side to side and top to bottom while pulling outwards to free the catalysts from the opening.
5. Remove any remaining gasket material from the openings and from the catalysts.
6. Inspect the catalysts for any fly ash or clogging, and remove with a soft bristled brush or vacuum crevice tool. If extra cleaning is needed, follow the guidelines below:
 - You may use compressed air under 35 psi, air only, no chemicals.
 - You may soak the catalysts in a hot water mix (not boiling), 4 parts water, 1 part vinegar. Rinse with cold water until vinegar smell is mostly gone.

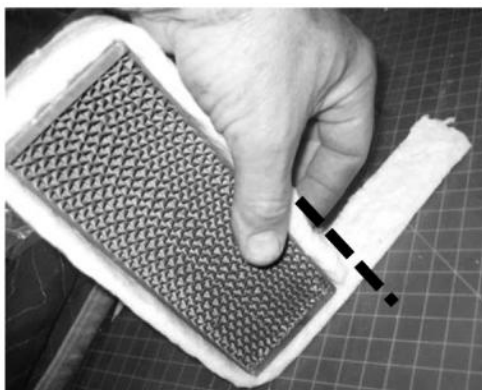

Figure 20 - Installing Gasket on Catalyst

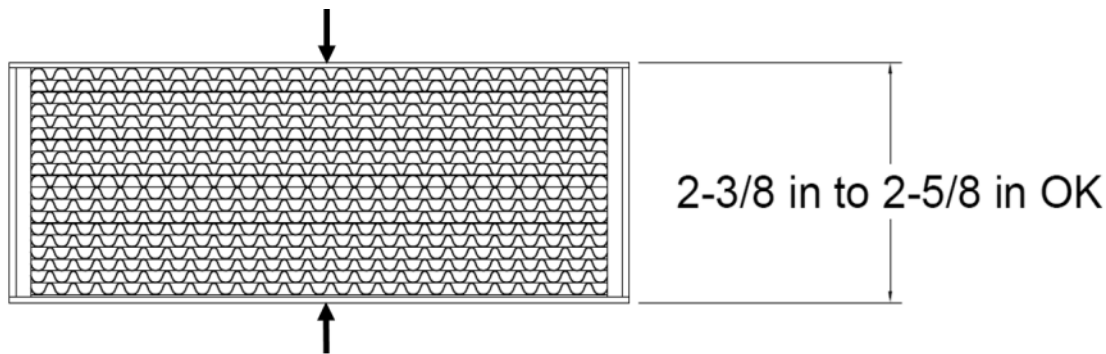

Figure 21 - Acceptable Catalytic Distortion

-No metal tools such as gun cleaners should be used.

-No detergents or chemicals.

7. Re-install ceramic wool gasket material on the catalysts. Keep the gasket material flush with one side of the catalyst. Masking tape can be used to hold the gasket in place on the catalyst. It will burn away when the stove gets hot. Wrap the tape around the gasket and catalyst so it is reasonably tight and some of the tape side is hanging over the edge of the catalyst, all around. Fold the edges of the tape in over the catalyst face. Finally add 3 smaller strips of tape as shown to hold gasket snug at ends and in the middle. This will reduce snagging and make it easier to reinstall the catalyst.
8. Only remove the catalysts if required. In general, the less you handle the catalysts, the better. If any unusual conditions are found, remove the catalyst blocks – See replacing the catalysts.
9. Some warping or bowing of the catalysts over time is acceptable, as long as the catalyst gasket continues to seal. Measure the catalyst in the middle section – if the dimensions are outside the range shown in Figure 21 above, replace the catalyst.
10. Once the gasket is installed on the catalysts, gently push the catalyst into the catalyst opening until the catalyst hits against the back wall of the cavity. Take care to ensure the gasket is not damaged.

4. Support the rear baffle while pulling the rear baffle support outwards towards the front of the stove (B)
5. Remove the rear baffle.
6. Installation is the reverse of removal.
7. Allow the stove and ashes to fully cool.
8. Follow the procedures from “INSPECTING THE CATALYSTS AND REMOVING/REPLACING THE FRONT BAFFLE” to remove the front baffle.
9. Remove the cotter pin securing the rear baffle support to the catalyst housing (A)
10. Support the rear baffle while pulling the rear baffle support outwards towards the front of the stove (B)
11. Remove the rear baffle.
12. Installation is the reverse of removal.
13. Allow the stove and ashes to fully cool.
14. Follow the procedures from “INSPECTING THE CATALYSTS AND REMOVING/REPLACING THE FRONT BAFFLE” to remove the front baffle.
15. Remove the cotter pin securing the rear baffle support to the catalyst housing (A)
16. Support the rear baffle while pulling the rear baffle support outwards towards the front of the stove (B)
17. Remove the rear baffle.
18. Installation is the reverse of removal.

REMOVING/REPLACING THE REAR BAFFLE

1. Allow the stove and ashes to fully cool.
2. Follow the procedures from “INSPECTING THE CATALYSTS AND REMOVING/REPLACING THE FRONT BAFFLE” to remove the front baffle.
3. Remove the cotter pin securing the rear baffle support to the catalyst housing (A). See Figure 22.

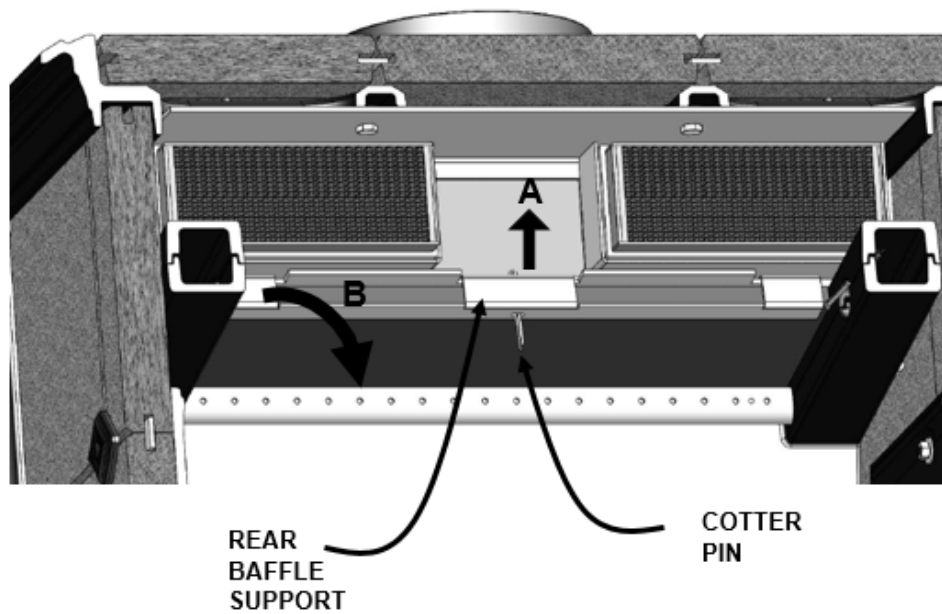
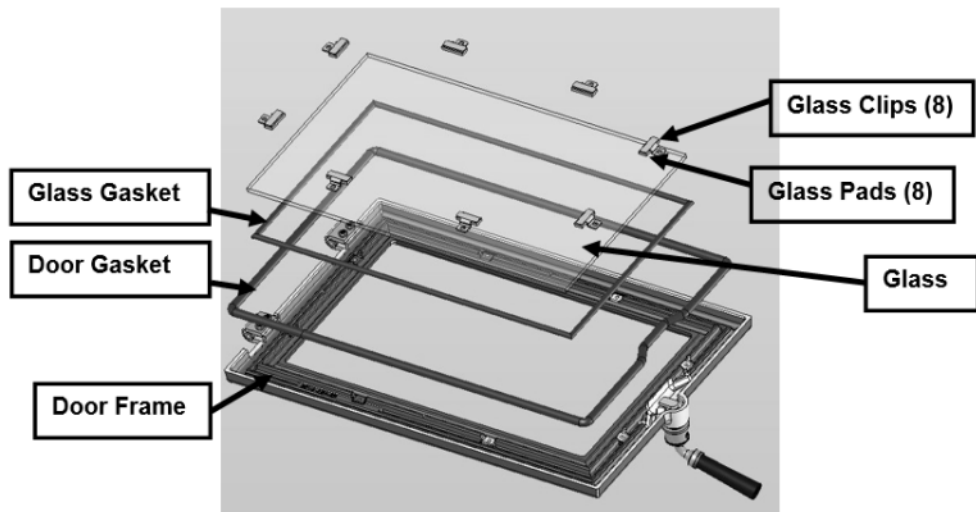

Figure 22 - Removing the Rear Baffle



GLASS REPLACEMENT PROCEDURES

- **WARNING: DO NOT OPERATE THIS APPLIANCE WITH THE GLASS PANEL REMOVED, CRACKED, OR BROKEN. DO NOT SUBJECT THE DOOR TO ABUSE, SUCH AS STRIKING OR SLAMMING SHUT. ONLY A QUALIFIED SERVICE PERSON SHOULD REPLACE THE GLASS PANEL.**
1. Follow the instructions included with the replacement glass kit.
 2. Remove the door.
 3. Remove the screws from the glass retainer (use penetrating oil if necessary) – lift the retainer off the glass. Set aside for reinstallation.
 4. Carefully lift the damaged glass out of the door and discard.
 5. Remove any remaining glass and old gasket material.
 6. Clean the screw holes and place a small amount of anti-seize compound in each one.
 7. Place the new glass onto the door. **Ensure sticker indicating the coated side is on the exterior face of the glass.**
 8. **Important! Center the glass** and ensure that the edges of the glass are parallel with the edges of the opening.
 9. Check glass position again (centered, and parallel), then screw the glass retainer clips with the glass pads back on the door using a crisscross pattern. Tighten the screws no more

than 1/8th of a turn after they seat. The glass will break at this point if not positioned correctly.

10. Apply a light film of anti-seize lubricant on the door's hinge pins if needed.
11. Install the door.
12. After 5 or 6 fires, check the glass retainer screws, and retighten if necessary.

Required Glass Kit: Part Number: 90-58300. Use only 5mm x 241mm x 390mm Ceramic IR, or Neoceram IR glass. Contact your Hearthstone dealer.

CREOSOTE FORMATION & REMOVAL

When wood burns slowly at low temperatures, it may produce tar and other organic vapors, which combine with expelled moisture to form creosote. These creosote vapors condense in the relatively cool chimney flue of a slow-burning fire. As a result, creosote residue accumulates on the flue lining. When ignited, this creosote makes an extremely hot fire, which may damage the chimney or even destroy the house. When burning wood, inspect the chimney connector and chimney at least once every two months during the heating season to determine if there is a creosote buildup.

If a creosote build-up occurs, inspect the stovepipe connector and chimney more often, at least monthly during the heating season to monitor the accumulation. If a creosote residue greater than 1/4" (6 mm) accumulates, remove it to reduce the risk of a chimney fire.

PREVENTION

Burn the stove with the primary air control fully open for 35 - 45 minutes daily to burn out creosote deposits from within the stove and the venting system.

After reloading with wood, burn the stove with the primary air control fully open for 15 to 20 minutes. This manner of operation ensures early engagement of the secondary combustion system that minimizes creosote buildup in the chimney.

If your glass always remains dirty, your operating temperatures are too low or your wood is wet; therefore, there is a higher risk of creosote buildup.

Inspect the venting system at the stove connection *and* at the chimney top. Cooler surfaces tend to build creosote deposits faster, so it is important to check the chimney at the top (where it is coolest) as well as from the bottom near the stove.

CLEANING

Remove accumulated creosote with a cleaning brush specifically designed for the type of chimney in use. We recommend you use a certified chimney sweep to perform this service. Contact your dealer for the name of a certified chimney sweep in your area (your dealer may be a certified sweep!).

We recommend that before each heating season you have the entire system professionally inspected, cleaned and repaired, if necessary.

GASKETS

Replace door gasket material every two to three seasons, or whenever it becomes deteriorated or loose, depending on stove use. If the door seal leaks, a new gasket will ensure a tight seal and improve stove performance.

We recommend you only use Hearthstone replacement gaskets when you need to replace your door gasket. Contact your dealer for a gasket kit that includes instructions, and the gasket for your stove.

GLASS

The glass used in our stoves is actually not plain glass, but a tough, clear ceramic material capable of operating at temperatures up to 2300° F. Do not operate the stove with a broken door glass. Do not abuse the front door by striking or slamming.

When necessary, clean the glass. For the inside surface of the glass, we recommend using a damp paper towel dipped in gray ash. Rub the inside of the glass with a circular motion. When all the deposits are removed, clean up with window cleaner or with commercial stove glass cleaners, which are available from your local dealer. Use this type of cleaner for the outside surface as well. Never attempt to clean the glass while the fire is burning or while the glass is hot. Remove deposits by following the instructions provided with the cleaner. Wipe the cleaner off with a soft cloth, or black & white newsprint.

Important: scratching or etching the glass will weaken the integrity of the glass. Do not use a razor blade, steel wool, or any other abrasive material to clean the glass. Use a cleaner specifically manufactured for woodstoves only.

The front door glass is a ceramic, thermal shock-resistant glass, made specifically for use in woodstoves. Do not use any replacement glass other than the ceramic glass manufactured and

supplied for use in this woodstove. Replacement glass is available through your local dealer.

Replace the door glass immediately if broken or chipped. Contact your local dealer for replacement glass. The glass kit includes instructions and everything needed for the repair. If you replace the glass yourself, wear work gloves and safety glasses.

Required Glass Kit: PN: 90-58300.

Troubleshooting

COMMON ISSUES

Virtually all woodstove operators experience basic common problems at one time or another. Most are correctable and generally require only a minor adjustment of the stove, installation, or operating technique. In cases where weather conditions dramatically affect stove performance, the problems are typically temporary and solve themselves once the weather changes.

If you question whether your stove is producing adequate heat, the best way to troubleshoot the problem is to monitor the temperature of the stack no more than 12 inches (30 cm) above the flue collar. A 400° F (200° C) stovepipe confirms the stove is supplying sufficient heat. Keep in mind that your house itself will regulate room/house temperatures. How well the walls, floors and ceilings are insulated, the number and size of windows, the tightness of outside doors, and the construction or style of your house (vaulted ceilings or other open spaces which collect large percentages of heat, ceiling fans, etc.) all are determining factors of room temperature.

Your stove's performance is also dependent on its installation. One common cause of poor performance is an oversized chimney flue. Oversized chimney flues result in decreased draft, which prevents the smoke from rising out the chimney. Oversized flues are also more difficult to heat effectively, especially when burning a high efficiency stove. Cool flue temperatures inhibit the establishment of a strong draft (and encourage the accumulation of creosote). The lack of a strong draft will cause the fire to die down and may even force smoke to pour into the room.

If your chimney is the proper size and a strong draft is not easily established, there is the possibility that the chimney is too cold. Again, hot chimneys promote stronger drafts. Opening a window briefly in the room while lighting the stove may help.

Other draft guidelines are as follows:

An **"AIRTIGHT" HOUSE:** The air supply (infiltration) to the interior of the house may be inadequate if your home is super-insulated or especially well sealed. This phenomenon of air starvation within the building is exacerbated if exhaust fans, such as clothes dryers, bathroom fans or cook stove exhaust fans, are in operation within the home. Outfitting your stove with the optional outside air adaptor connected to an air duct, which leads to the outside of the building, can correct this problem.

Tall Trees or Buildings: These obstructions, when located close to the top of the chimney can cause chronic or occasional downdrafts. When selecting a site for a new chimney, consider the placement of other objects near the proposed chimney location.

Wind Velocity: Generally, the stronger and steadier a wind, the stronger (better) the draft. However, "gusty" wind conditions can cause erratic downdrafts. For consistent problems, consider a high wind cap, such as the Vacu-Stack.

Barometric Pressure: Chimney drafts are typically sluggish on balmy, wet or muggy days (low barometric pressure). This is a weather-related phenomenon, which generally is self-correcting as the weather changes.

Briskness of Fire: The hotter the fire in your stove, the hotter your chimney and, therefore, the stronger the draft.

Breaks in the Venting System: An unsealed clean-out door at the bottom of the chimney, leaky stovepipe joints, a poor stovepipe-to-thimble connection, missing caps, or a leaky chimney all can cause inadequate draft.

Seasonal Factors: Early fall and late spring are generally difficult seasons in which to establish proper drafts. The colder the outside air is relative to room temperature, the stronger the draft.

OPERATING THE STOVE

As outlined above, there are days when a good draft is just not easy to establish. The causes are usually seasonal factors or a cold chimney. Try starting the fire by using small kindling and fuel to obtain a quick, hot fire. Tend the fire frequently with small fuel until the chimney is hot and the draft is well established. Sometimes, partially opening a first floor window briefly will help quickly get draft established.

TROUBLESHOOTING GUIDE

PROBLEM	POSSIBLE CAUSE	SOLUTIONS
STOVE SMOKES	Operating Technique	Fully open the primary air control one minute before opening doors, and ensure the bypass is open before opening door.
	Cold Chimney or reverse draft	Preheat the chimney when first starting a fire. Briefly open a window in the room containing the stove.
	Blocked Chimney	Examine the chimney and stovepipe for blockage or creosote accumulations.
	Oversized Chimney	Reline the chimney to the appropriate diameter
	Undersized Chimney	Install a draft inducer or replace the chimney.
	Chimney Too Short	Lengthen the chimney.
	Air Infiltration Into The Chimney	Seal chimney connections and openings. Check clean-out doors.
	Bypass not closed	Ensure that the bypass door is closed when the catalyst is in the active range.
	Catalyst not functioning	Inspect catalyst for damage, ash build-up, or plugging. Brush catalyst with a soft-bristled brush, or vacuum lightly. Replace if required. Follow instructions to ensure catalyst light-off.
	Not burning proper fuel	Ensure cordwood is seasoned and dry.
More Than One Appliance Connected to the Flue	Disconnect all other appliances and seal openings.	
BACK-PUFFING OR GAS EXPLOSIONS	Operating Technique	Fully open the primary air control one minute before opening the door and keep it fully open for a few minutes after reloading. Ensure the bypass door is open before opening the door
	Extra Low Burn Rate	Burn the stove at a higher burn rate.
	Chimney Down-draft	Install a chimney cap.
	Excessive Ash Build-up	Empty the ash pan more frequently. Increase efficiency of burns, and avoid using poor quality or green wood.
UNCONTROLL- ED OR SHORT BURN	Unsealed or Open Door	Close the door tightly or replace the gaskets. Air leakage around glass gasket – replace gasket
	Excessive Draft	Check the installation. Operate at LOW BURN. Install stovepipe damper. Draft in excess of 0.1 wc should be corrected with a stovepipe damper(s)
	Extra Long Chimney	Shorten the chimney. Install stovepipe damper(s).
	Oversized Chimney	Reline the chimney to the proper diameter.
	High Winds or Hilltop Location:	Install a chimney cap.
INSUFFICIENT HEAT	Poor Quality, low Btu content, or Green Wood	Use only air-dried wood, preferably dried <u>at least</u> one year. Use a wood with a high Btu content if available.
	Low Burn Rate	Operate the stove at a higher burn rate.
	Cold Exterior Chimney	Reline or insulate the chimney.
	Leaky Stovepipe or Chimney	Check the installation. Replace with a pre-fabricated insulated chimney system or a properly sized masonry chimney.
	Too Much Heat Loss From House	Add insulation, use energy efficient windows, or caulk windows, and seal openings in home.
	Excessive Ash Build-up	Empty the ash pan more frequently. Increase efficiency of burns, and avoid using poor quality or green wood.
BLISTERING OF FINISH	Operating Technique	Do not over-fire the stove. Monitor stove temperatures. Use seasoned wood only.
	Excessive Draft	Check the DRAFT. A damper may be required. Operate the stove at a LOW BURN range.

ADDITIONAL CATALYST TROUBLESHOOTING GUIDE

PROBLEM	POSSIBLE CAUSE	SOLUTIONS
FLY ASH BUILD UP ON CATALYST	Catalyst has not maintained light-off temperature	Brush cold combustor with soft-bristled brush or vacuum lightly. Follow instructions in the manual for a proper catalyst light-off
	Burning materials that cause a lot of char and fly-ash	Don't burn cardboard, gift wrap paper, or garbage. Burn only dry, seasoned wood, per the owner's manual.
	Bypass closed too soon	Follow instructions in the manual for a proper catalyst light-off
CATALYST PLUGGING OR MASKING (SOOT/CREOSOTE)	Burning wet, pitchy woods, or burning large loads of small diameter wood with the combustor in the operating position without catalyst light off occurring	Burn dry seasoned wood. Follow instructions in the manual for a proper catalyst light-off, and ensure catalyst light-off as occurred before closing bypass damper. It may be possible to burn the soot or creosote off by building a hot fire, and allowing the stove to run until the catalyst is well within the operating range before closing the bypass. Continue to run the stove at a high temperature for one hour, while ensuring the catalyst stays in the upper operating range, but not too hot.
WARPING OR BOWING OF THE CATALYST	Excessive catalyst temperatures for long periods of time.	Ensure that the catalyst remains in the operating zone, and does not get too hot. Reduce air control settings for a lower burn rate to ensure catalyst temperatures do not exceed the operating range.

SAFETY LABEL (FRONT)

CONTACT YOUR LOCAL BUILDING OFFICIALS ABOUT
RESTRICTIONS AND INSTALLATION INSPECTION IN YOUR AREA

Listed Room Heater, Solid Fuel Type
Also Suitable for Mobile Home Installation Pursuant to (UM)84-HUD



Conforms to UL STD 1482
Certified to ULC STD S627

Manufactured by:



317 Stafford Ave.
Morrisville, VT 05661

MODEL NAME:
CASTLETON 1
MODEL NUMBER: 8031
SERIAL NUMBER:
[REDACTED]



CAUTION: HOT WHILE IN OPERATION.
DO NOT TOUCH. KEEP
CHILDREN, CLOTHING, AND FURNITURE AWAY.
CONTACT MAY CAUSE SKIN BURNS. SEE NAMEPLATE
AND INSTRUCTIONS. INSPECT AND CLEAN CHIMNEY
AND CONNECTOR FREQUENTLY. UNDER CERTAIN
CONDITIONS OF USE, CREOSOTE BUILDUP MAY
OCCUR RAPIDLY.

WARNINGS

Do not use grate or elevate fire. Build wood fire directly on hearth. Do not overfire. If the heater or chimney connector glows, you are overfiring.
(See Operator's Manual)

OPERATE ONLY WITH DOORS CLOSED. DO NOT OBSTRUCT SPACE UNDER HEATER.
TYPE OF FUEL: CORD WOOD ONLY - BURNING FUELS OTHER THAN CORDWOOD MAY DAMAGE THE APPLIANCE

"PREVENT HOUSE FIRES"

Install and use only in accordance with manufacturer's installation instructions and your local building codes.

CAUTION: Special methods are required when passing chimney through a wall or ceiling, refer to local building codes. Do not connect this unit to a chimney flue serving another appliance.

NOTE: Replace glass only with 5mm ceramic glass.

This wood heater needs periodic inspection and repair for proper operation. Consult the owner's manual for further information.
It is against federal regulations to operate this wood heater in a manner inconsistent with the operating instructions in the owner's manual.

WARNING: (Mobile Home) An outside air inlet must be provided for combustion and be unrestricted while the unit is in use.

THIS APPLIANCE USES A CATALYTIC COMBUSTOR (P/N P/N WF-4150001076)
The performance of the catalytic device or its durability has not been evaluated as part of the certification
CAUTION: Burning materials other than the specified fuels may make the catalyst inactive

3300-721

SAFETY LABEL (REAR)

Minimum Clearance to Combustible Materials*

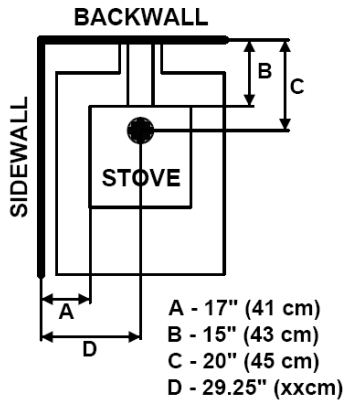

Floor Protection*

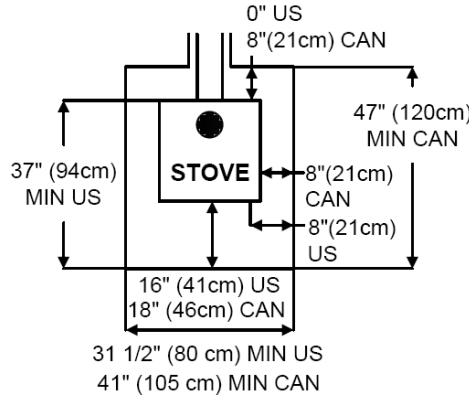

When installed on a combustibles floor, non-combustibles floor protection is required to cover the area beneath the heater, and extend at least 16" (41cm) [18" (46cm) CAN] to the front and 8" (21cm) beyond each side of the fuel loading and ash removal openings [side of stove in CAN], the floor protection must extend under the flue connector and extend 2" beyond each side of pipe.

VENT REQUIREMENTS: 6" diameter, single wall, minimum 24 MSG blue steel connector with listed factory-built Type HT chimney or masonry chimney.

OPTIONAL COMPONENTS:

Rear Heatshield	Part #90-68300
Blower Kit	Part #90-57210
Outside Air Kit	Part #90-53300
Spark Screen	Part #90-69300

*Refer to the installation Manual for additional clearance information, installation instructions, and operating instructions.

U.S. ENVIRONMENTAL PROTECTION AGENCY
 Particulate Emissions: 0.7 g/hr. Tested to: EPA Method 28R
 Certified to comply with 2020 crib wood particulate emission standards.

Date of Manufacture

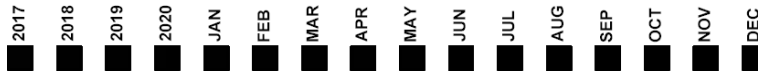

DO NOT REMOVE OR COVER THIS LABEL

MADE IN USA

3300-721



LIMITED WARRANTY

These warranties give you specific legal rights. You may also have other rights, which vary from State to State.

Hearthstone Quality Home Heating Products, Inc. (Hearthstone) warrants to the original retail purchaser only (the "Original Purchaser") the new appliance manufactured by Hearthstone, purchased by the Original Purchaser and installed by an authorized Hearthstone dealer or their designated representative against any of the occurrences listed in this document that result from defects in material or workmanship. This warranty is not transferrable. All obligations of Hearthstone under this document commence on the date of the Original Invoice (the "Purchase Date"). The term "Limited Lifetime" is defined as 10 years from the beginning of warranty coverage.

Hearthstone appliances are designed to be operated only with the fuels listed in your owner's manual.

Catalytic combustor LIMITED LIFETIME WARRANTY: The catalytic combustors are covered directly by the combustor manufacturer, Applied Ceramics. Included with your stove you will find the LIMITED LIFETIME WARRANTY for the catalyst, as well as a warranty card.

Catalyst Model Number: ACI-6M2 Catalyst Manufacturer: APPLIED CERAMICS

APPLIED CERAMICS warrants to the consumer who purchases a FIRECAT STEEL COMBUSTOR as a component in an EPA certified solid fuel appliance, to replace at no charge to the consumer the FIRECAT STEEL COMBUSTOR that ceases to function with two (2) years from the date of purchase by the original consumer, provided that the following conditions are met:

- (1) A copy of the original bill of sale that includes place and date of purchase must be submitted with the warranty claim.
- (2) The original FIRECAT STEEL COMBUSTOR must be returned to APPLIED CERAMICS
- (3) The FIRECAT STEEL COMBUSTOR must not have been mechanically abused, nor must the wrong fuels have been used in the appliance.

If after two years the FIRECAT STEEL COMBUSTOR fails to function, the prorated warranty will allow replacement at the following special price schedule:

Year 3	\$130.00
Year 4	\$140.00
Year 5	\$150.00
Year 6	\$160.00
Year 7 and after	at current retail price

Conditions 1, 2, and 3 also apply to the Prorated portion of the warranty. Any EPA certified solid fuel appliance will receive one replacement catalyst for each defective catalyst returned during the three year period. The consumer will be responsible for any removal, any servicing, and return of any items required for filing the warranty claim. This warranty is APPLIED CERAMIC'S exclusive warranty, and APPLIED CERAMICS, disclaims any other express or implied warranty for the FIRECAT STEEL COMBUSTOR, including any warranty or merchantability fitness for a particular use.

Ensure the catalyst is well wrapped and padded for shipment in bubble wrap, or similar material. Ship the catalyst with padding inside of a cardboard box.

All warranty claims must include \$12.50 for postage and handling within the continental U.S. Alaska and Canada claims must include \$35.00.
 Please allow 2-3 weeks for delivery. Order online @ www.firecatcombustors.com

Please read and understand the full warranty. Please return the completed warranty card promptly to Applied Ceramics. The warranty card, and any warranty claims can be shipped to:

Applied Ceramics
55555 Pleasantdale Road
Doraville, GA, 30340

Stove components Limited Warranty

Warranty Period	Wood	Gas	Pellet	Covered Components
Limited Lifetime	X	X	X	Stone
	X	X	X	Cast iron not listed elsewhere
	X			Clean burning air supply system*
5 Year	X	X	X	Door handles and latches
	X	X	X	Steel Components and Firebox
		X		Burner and logs
3 Year			X	Burn Pot and Baffles
2 Year	X	X	X	Appliance Electrical and Gas Components
	X	X		Refractory, Vermiculite Panels, Baffles
1 Year	X	X	X	Enamel finish against peeling or fading
	X	X	X	Accessories
	X	X	X	Glass
	X			Ash Grate
	X	X	X	All components not listed elsewhere

Any parts repaired or replaced during the limited warranty period will be warranted under the terms of the limited warranty for a period not to exceed the remaining term of the original limited warranty or one year, whichever is longer.

Parts: Hearthstone will replace through an authorized dealer, defective parts covered by the foregoing warranty at no charge.

Labor: Within the first (1st) year after the Purchase Date, Hearthstone will pay for warranty labor performed by an authorized Dealer at Hearthstone’s published labor rates in effect at the time the labor is performed only if the appliance is installed by an authorized dealer or their designated representative. Otherwise or thereafter, the Original Purchaser is responsible for the cost of labor.

Shipping cost for parts: Within the first ninety (90) days after the Purchase Date, Hearthstone will pay for the shipping of appliance parts covered by any of the foregoing warranties to and from Hearthstone or an authorized Dealer, as the case may be. Thereafter, the Original Purchaser is responsible for all shipping costs related to shipping appliance parts to and from Hearthstone or an authorized Dealer, as the case may be.

Shipping cost for the appliance: Within the first (1st) year after the Purchase Date, if the Original Purchaser is instructed to return the appliance to Hearthstone or an authorized Dealer for repair, Hearthstone will pay fifty percent (50%) and the Original Purchaser will pay fifty percent (50%) of the shipping costs related to shipping the appliance to and from Hearthstone or an authorized Dealer, as the case may be. Thereafter, the Original Purchaser is responsible for one hundred percent (100%) of all of the shipping costs related to shipping the appliance to and from Hearthstone or an authorized Dealer, as the case may be. Notwithstanding any other provision of this document, in no event will Hearthstone pay for any Dealer fees or other fees for pick up or delivery of the appliance returned for repair; the Original Purchaser shall be responsible for any such fees.

EXCLUSIONS & CONDITIONS

The warranties contained in this document do not cover, nor is Hearthstone responsible for:

1. Damages resulting from:
 - a. Failure to install, operate, or maintain the appliance in accordance with the owner's manual, operating instructions, installation instructions, or safety rating label provided with the appliance.
 - b. Over-firing the appliance. Over-firing can be identified by, but not limited to, warped cast iron or steel, rust colored cast iron, bubbling, cracking and discoloration of steel or enamel finishes.
 - c. Failure to install the appliance in accordance with all national or local building codes.
 - d. Shipping or improper handling.
 - e. Improper operation, abuse, misuse, continued operation with damaged, corroded, or failed components, accident, or improper/incorrect service or repairs.
 - f. Environmental conditions, inadequate ventilation, negative pressure, or improper drafting caused by tightly sealed constructions, insufficient make-up air supply, or air handling devices such as exhaust fans, forced air furnaces, or other such causes.
 - g. Damage caused by direct exposure to water.
 - h. Use of fuels other than those specified in the owner's manual.
 - i. Installation or use of components not supplied with the appliance, or any other components not expressly authorized and approved by Hearthstone.
 - j. Modifications of the appliance not expressly authorized and approved by Hearthstone in writing
 - k. Interruptions or fluctuations of electrical power supplied to the appliance.
2. All stones are warranted against cracking or breakage due to thermal stress, excluding surface and hairline cracks and scratches that do not affect the operation, or safety of the appliance.
3. Repair or replacement of wear parts. Such parts that are subject to normal wear and tear during the warranty period such as paint, gaskets, baffles, refractory materials, ash grates, and glass.
4. Damage resulting from installation, modification, alteration, repair or service of the appliance by any party other than an authorized Hearthstone dealer (a "Dealer") or their designated representative, or Hearthstone.
5. Damage due to water or condensation due to installation of the appliance in a high moisture area.
6. Damage due to installation of the appliance in an atmosphere contaminated by damaging chemicals, including but not limited to chlorine, fluorine or salts.
7. Scratches on glass, enameled surfaces or stones due to mechanical abrasion.
8. Noise caused by expansion or contraction caused by the heating and cooling of the appliance.
9. Odors caused by the heating of the appliance, or surrounding materials
10. Consequential damage caused by leaking of condensate during startup
11. A defect in any part of the appliance if the Original Purchaser fails to comply with Hearthstone's or a Dealer's request to ship the part or the appliance to Hearthstone or a Dealer, as the case may be.
12. Replacement stones and enameled parts are taken from current stock, and may not match originals in color, grain, or pattern. Hearthstone will supply replacement parts for discontinued parts in finishes or colors as available, or at their discretion.
13. Hearthstone's obligation under this warranty does not extend to the appliance's ability to heat the desired space. Information is provided to assist the customer and the dealer in selecting the appropriate appliance for the application. Consideration must be given to appliance location and configuration, environmental conditions, insulation and air tightness of the structure.

THE WARRANTIES CONTAINED IN THIS DOCUMENT ARE EXCLUSIVE AND ARE GIVEN BY HEARTHSTONE AND ACCEPTED BY THE ORIGINAL PURCHASER IN LIEU OF ALL OTHER EXPRESS WARRANTIES AND ANY OBLIGATIONS, LIABILITIES, RIGHTS, CLAIMS, OR REMEDIES IN CONTRACT OR TORT, WHETHER OR NOT ARISING FROM HEARTHSTONE'S NEGLIGENCE, ACTUAL OR IMPUTED. ALL IMPLIED WARRANTIES, INCLUDING THE WARRANTIES OF MERCHANTABILITY AND FITNESS FOR A PARTICULAR PURPOSE, ARE GIVEN ONLY TO THE EXTENT REQUIRED BY FEDERAL OR STATE LAW. EXCEPT AS OTHERWISE REQUIRED BY STATE LAW, UPON THE EXPIRATION OF THE EXPRESS LIMITED WARRANTIES CONTAINED HEREIN, NO IMPLIED WARRANTIES, INCLUDING THE IMPLIED WARRANTIES OF MERCHANTABILITY OR FITNESS FOR A PARTICULAR PURPOSE, SHALL APPLY TO THE SUBJECT APPLIANCE. SOME STATES DO NOT ALLOW LIMITATIONS ON HOW LONG AN IMPLIED WARRANTY LASTS, SO THE ABOVE LIMITATION MAY NOT APPLY TO YOU.

THE WARRANTIES CONTAINED IN THIS DOCUMENT EXTEND ONLY TO THE ORIGINAL PURCHASER OF THE APPLIANCE WARRANTED HEREUNDER. THEY ARE NOT TRANSFERRABLE AND DO NOT EXTEND TO ANY SUBSEQUENT OWNERS.

UNDER NO CIRCUMSTANCES SHALL HEARTHSTONE BE LIABLE TO THE ORIGINAL PURCHASER OR ANY OTHER PERSON FOR ANY INCIDENTAL OR CONSEQUENTIAL DAMAGES, INCLUDING BUT NOT LIMITED TO DAMAGE TO PROPERTY OR PERSONAL INJURIES, WHETHER ARISING OUT OF LOSS OF USE, BREACH OF WARRANTY, TORT, OR OTHERWISE, EVEN IF HEARTHSTONE HAS BEEN APPRAISED OF THE POSSIBILITY OF SUCH DAMAGES. SOME STATES DO NOT ALLOW THE EXCLUSION OR LIMITATION OF INCIDENTAL OR CONSEQUENTIAL DAMAGES, SO THE ABOVE LIMITATION OR EXCLUSION MAY NOT APPLY TO YOU.

QUALIFYING FOR WARRANTY COVERAGE

To obtain performance of any obligation under this document, the Original Purchaser must, within the applicable warranty time period, contact their original Hearthstone dealer, or the current responsible local Hearthstone dealer, for instructions regarding the return of defective parts for repair, the return of the appliance for repair, or to schedule a Dealer service call. The Original Purchaser should refer to the Dealer Network search engine contained on Hearthstone's Web site (www.hearthstonestoves.com) if the original dealer is not available, to find a Hearthstone dealer nearest to the Original Purchaser's location.

REMEDY

The remedy for any breach of the foregoing warranties will consist of repair or replacement, at Hearthstone's option, of any covered defect in the appliance. When the Original Purchaser contacts a Hearthstone Dealer, the Dealer on behalf of Hearthstone, as the case may be, will instruct the Original Purchaser to either return the defective part, or the entire appliance (if requested), to the Dealer or Hearthstone or allow a Dealer to make a service call at the place where the appliance is located. Hearthstone may require that a digital picture be provided to support the claim. Notwithstanding any other provision of this document, the Original Purchaser shall pay for any fees and service charges related to a Dealer's service call or the shipping charges associated with the return.

WARRANTY REGISTRATION

The Original Purchaser can complete their warranty registration on our website at www.hearthstonestoves.com, or send a completed and signed Warranty Registration Form, which is enclosed in the appliance document packet, to the following address:

Hearthstone Quality Home Heating Products, Inc.
Warranty Department
317 Stafford Avenue
Morrisville, VT 05661

NOTE: SENDING IN THE SIGNED WARRANTY REGISTRATION FORM IS *NOT REQUIRED* AS A CONDITION OF WARRANTY COVERAGE OR HEARTHSTONE'S PERFORMANCE.