

Owner's Manual

Installation and Appliance Setup - Care and Operation

INSTALLER: Leave this manual with party responsible for use and operation.

OWNER: Retain this manual for future reference.

Call your dealer for questions on Installation, Operation, or Service.

This unit has been retired. Service parts pages within have been removed. For replacement parts, please refer to the individual service parts list located on the brand website.

NOTICE: SAVE THESE INSTRUCTIONS

HARMAN®

BUILT TO A STANDARD, NOT A PRICE

Model(s):
Oakwood Wood Stove

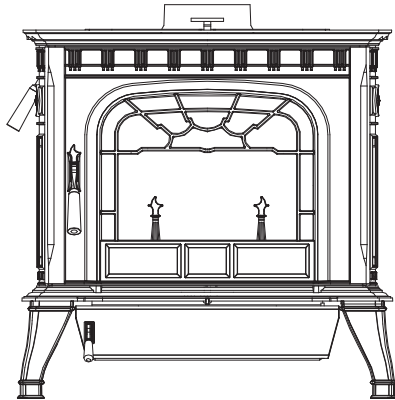

Wood Stove
Use & Care Video

Tested & Listed By **OMNI** US
OMNI-Test Laboratories, Inc. Portland Oregon USA

We suggest that our hearth products be installed and serviced by professionals who are certified in the U.S. by the National Fireplace Institute (NFI) as NFI Specialists.

⚠ WARNING



Please read this entire manual before installation and use of this wood-burning room heater.

Failure to follow these instructions could result in property damage, bodily injury or even death.

- Do not store or use gasoline or other flammable vapors and liquids in the vicinity of this or any other appliance.
- Do not overfire - If any external part starts to glow, you are overfiring. Close air controls. Overfiring will void your warranty.
- Comply with all minimum clearances to combustibles as specified. Failure to comply may cause a house fire.

⚠ WARNING



HOT SURFACES!

Glass and other surfaces are hot during operation and cool down.

Hot glass will cause burns.

- Do not touch glass until it is cooled
 - NEVER allow children to touch glass
 - Keep children away
 - CAREFULLY SUPERVISE children in same room as stove.
 - Alert children and adults to hazards of high temperatures.
- High temperatures may ignite clothing or other flammable materials.**
- Keep clothing, furniture, draperies and other flammable materials away.

⚠ CAUTION

Tested and approved for use with dry, seasoned cordwood only. Do Not Burn Wet or Green Wood. Burning any other type of fuel will void your warranty.

⚠ CAUTION

Check building codes prior to installation.

- Installation MUST comply with local, regional, state and national codes and regulations.
- Contact local building or fire officials about restrictions and installation inspection requirements in your area.

NOTICE

To obtain a French translation of this manual, please contact your dealer or visit www.harmanstoves.com.

Pour obtenir une traduction française de ce manuel, s'il vous plaît contacter votre revendeur ou visitez www.harmanstoves.com.

Hearth & Home Technologies welcomes you to our tradition of excellence! By choosing a Harman appliance, you have become part of our commitment to meeting the heating needs of consumers with the most distinctive, powerful and responsible home heating products available.

The Oakwood has huge features in an elegantly small package, the Oakwood takes advantage of Harman's 30+ years of stove design, technology and manufacturing. The Firedome secondary combustion system provides for super-clean burning and minimal maintenance. The top-loading feature makes for more convenient loading, with enough fuel for an all day burn.

We wish you and your family many years of enjoyment in the warmth and comfort of your hearth appliance.

Thank you for choosing Harman.

This Label is located on the rear of the appliance. It contains important safety test information as well as the clearances to combustible materials. The label also contains the appliance serial number. For your records, copy your serial number and purchase date here.

Date of Purchase: _____

Serial #: _____



MODEL / MODÈLE: "Oakwood" Woodburning Stove
Room Heater Solid Fuel Burning Type
NOT SUITABLE FOR MOBILE-HOME INSTALLATION

Serial No.
N° de série: **HF**

BARCODE LABEL

Report #/Rapport #135-S-11-2
Tested to/Testé selon: UL 1482-1996, UL 737-1996, ULC-S627-00, EPA Method 28 & 5G
 Not approved for Use in Mobile/Manufactured Homes
"PREVENT HOUSE FIRES" Install and use only in accordance with manufacturer's installation and operation instructions and local codes. In absence of local codes, installation must meet minimum requirements of NFPA 211 in USA. Refer to manufacturer's instructions and local codes for precautions required for passing chimney through a combustible wall or ceiling.
 This wood heater needs periodic inspection and repair for proper operation. Consult the owner's manual for further information. It is against federal regulations to operate this wood heater in a manner inconsistent with the operating instructions in the owner's manual.
 Flue connector pipe must be 6" diameter, minimum 24 MSG blue steel. Chimney must be factory built 103HT or masonry construction. Contact Local Building or Fire Officials about restrictions and installation inspection in your area.
DO NOT CONNECT THIS APPLIANCE TO A CHIMNEY SERVING ANOTHER APPLIANCE.
FOR USE WITH SOLID WOOD FUEL ONLY, DO NOT BURN COAL.
 EPA Certified Emissions: 2.3 g/hr
 Fuel Type: Cord Wood
DO NOT Overfire - If Heater or chimney connector glows, you are overfiring.
Route power cord away from unit.
OPERATE ONLY WITH DOORS CLOSED
 Replace glass only with 5mm ceramic, available from your dealer.
 Do not obstruct airflow under the appliance.
DANGER: Risk of Fire or Explosion - Do not burn garbage, gasoline, drain oil or other flammable liquids.
WARNING: Risk of Fire, Do not operate with fuel loading or ash removal doors open.
 Do not store fuel or combustibles within marked clearances. Inspect and clean chimney and connector regularly - Under certain conditions of use, creosote buildup may occur rapidly.
 The Bypass Damper must be opened prior to opening any load or ash door.
 Do not install a grate or otherwise elevate the fire.
DO NOT REMOVE THIS LABEL / Ne pas enlever cette étiquette

CLEARANCE TO COMBUSTIBLE SURFACE	ESPACES LIBRES AUX COMBUSTIBLES	Floor protection must be a 3/4" min. thickness, non-combustible material having an equal or better insulating value (lower k value) of k=.84 BTU/in F ² Hr °F, extending beneath heater and to front/sides/rear as indicated. In Canada, required floor protection must be 18" (450mm) in front.
A - Unit to Side Wall 26" (660mm)	A - Du mur de côté à l'appareil 26" (660mm)	Le protecteur de plancher doit être d'une épaisseur minimum de 3/4" d'un matériau incombustible ayant une valeur d'isolation de k=.84 BTU/in F ² Hr °F. Il doit s'étendre et à l'arrière de l'appareil comme indiqué. 'Au Canada, la protection du plancher doit s'étendre de 18" (450mm) en avant.
B - Unit to Back Wall 28" (711mm)	B - Du mur arrière à l'appareil 28" (711mm)	
C - Chimney Connector to Side Wall 38" (965mm)	C - Du tuyau de cheminée au mur de côté 38" (965mm)	
D - Chimney Connector to Back Wall 32" (813mm)	D - Du tuyau de cheminée au mur arrière 32" (813mm)	
E - Unit to Adjacent wall 24" (610mm)	E - Entre le mur adjacent et l'appareil 24" (610mm)	
F - Chimney Connector to Adjacent wall 32" (813mm)	F - Entre le tuyau et le mur adjacent 32" (813mm)	



BACKWALL



ADJACENT WALL



US ENVIRONMENTAL PROTECTION AGENCY
 Certified to comply with 2015 particulate emission standards. Not approved for sale after May 15, 2020.
 Certifié conforme aux normes 2015 d'émission de particules. Non approuvé pour la vente après le 15 mai 2020.

Date of Manufacture / Date de fabrication:

2016	2017	2018	JAN	FEB	MAR	APR	MAY	JUN	JUL	AUG	SEP	OCT	NOV	DEC
■	■	■	■	■	■	■	■	■	■	■	■	■	■	■

Manufactured by / Fabriqué par: Hearth and Home Technologies 352 Mountain House Road, Halifax PA 17032



Made in U.S.A. of US and imported parts. / Fabriqué aux États-Unis-d'Amérique par des pièces d'origine américaine et pièces importées.

CAUTION: HOT WHILE IN OPERATION- DO NOT TOUCH- KEEP CHILDREN AND CLOTHING AWAY- CONTACT MAY CAUSE SKIN BURNS- SEE NAMEPLATE AND INSTRUCTIONS. KEEP FURNISHINGS AND OTHER COMBUSTIBLE MATERIALS A CONSIDERABLE DISTANCE AWAY FROM THE APPLIANCE



ATTENTION: CHAUD LORS DU FONCTIONNEMENT- NE TOUCHEZ PAS L'APPAREIL- GARDEZ LES ENFANTS ET LES VÊTEMENTS ÉLOIGNÉS- TOUT CONTACT PEUT ENTRAÎNER DES BRÛLURES DE LA PEAU. RÉFÉREZ-VOUS À LA PLAQUE SIGNALÉTIQUE ET AU MODE D'EMPLOI. GARDEZ LE MOBILIER ET LES AUTRES MATÉRIEAUX COMBUSTIBLES BIEN À L'ÉCART DE L'APPAREIL.

3-90-249_R6

TABLE OF CONTENTS

1 Listing and Code Approvals

A. Appliance Certification	4
B. Mobile Home Approval	4
C. Glass Specifications	4
D. BTU & Efficiency Specifications	4

2 Special Warnings and Notes

A. Carbon Monoxide Warnings & Considerations	5
--	---

3 Getting Started

A. Design, Installation and Location	6
B. Fire Safety	6
C. Component Locator	7
D. Flue Direction Conversion	7
E. Pre-Use Checklist	8

4 Dimensions & Clearances

A. Appliance Dimensions	9
B. Clearances to Combustibles	10
C. Floor Protection	14

5 Chimneys and Venting

A. Draft	15
B. Chimney Connectors	15
C. Wall Pass-throughs	15
D. The Chimney	16

6 Appliance Set-Up

A. Outside Air Attachment	23
B. Leveling the Appliance	23
C. Optional Cooking Grill	23
D. Optional Rear Vent Shield	24
E. Bottom Heat Shield	24
F. Optional Cozy Screen	24

7 Operating Instructions

A. Fuel Specifications	25
B. General Operating Information	25
C. Combustion Process	26
D. User Controls	27
E. Before Your First Fire	27
F. Building and Maintaining a Fire	27

8 Service & Maintenance

A. Soot Formation (Removal)	29
B. General Maintenance Procedures	30

9 Reference Materials

A. Warranty Policy	32
B. Service & Maintenance Log	34

This room heater must be connected to:

1. A chimney complying with the requirements for Type HT chimneys in the standard for Chimneys, Factory-Built, Residential Type and Building Heating Appliance, UL 103

OR

2. A Code Approved Masonry Chimney with a Flue Liner.

→ = Contains updated information

1 Listing and Code Approvals

A. Appliance Certification

MODEL:	Oakwood Woodburning Stove
LABORATORY:	OMNI Test Laboratories, Inc
REPORT NO.	135-S-11-2
TYPE:	Solid Fuel Room Heater / Wood Burning Type
STANDARD(s):	UL 1482-1996, UL 737-1996, ULC-S627-00, EPA Method 28 & 5G

The Oakwood Woodburning Stove is Certified to comply with 2015 particulate emission standards. Not approved for sale after May 15, 2020.



B. Mobile Home Approved

This appliance is NOT approved for installation in mobile/manufactured homes.

C. Glass Specifications

This appliance is equipped with 5mm ceramic glass. Replace glass only with 5mm ceramic glass. Please contact your dealer for replacement glass if needed.

D. BTU & Efficiency Specifications

EPA Certification Number:	558
EPA Certified Emissions:	2.3 g/hr
*EPA Default Efficiency:	63%
**Actual tested Efficiency:	Not Tested
***EPA BTU Output:	10,900 - 30,500
****Peak BTU/Hour Output:	51,600
Other Important Information	
Vent Size:	6 Inch (152 mm)
Firebox Size:	2.3 cu. ft.
Max. Wood Length:	21" Maximum
Fuel	Seasoned Cordwood (20% moisture)

Note: When using the top loading feature some pieces of wood may need to be shorter to maximize loading.

**An efficiency based on EPA historical data: 63% for non-catalytic stoves.*

***Maximum calculated efficiency using Douglas Fire dimensional lumber and data collected during EPA emissions test.*

****A range of BTU outputs based on EPA Default Efficiency and the burn rates from the low and high EPA tests, using Douglas Fir dimensional lumber.*

*****A peak BTU out of the unit calculated using the maximum first hour burn rate from the High EPA Test and BTU content of seasoned cordwood (8600) times the efficiency.*

This wood heater needs periodic inspection and repair for proper operation. It is against federal regulations to operate this wood heater in a manner inconsistent with operating instructions in this manual.

2 Special Warnings and Notes

A. Carbon Monoxide Warnings & Considerations

Carbon monoxide, referred to as CO, is a colorless, odorless gas that is produced during combustion of wood and other fuels. **CO fumes are toxic and can be fatal.**

The Oakwood is a natural draft system which relies on a properly designed chimney to remove CO and other combustion by-products from the stove.

Even though this stove is designed to be as safe as possible, it is important that you **install a CO detector**. This is true for oil, gas, or coal burning products as well.

CO is not specifically heavier or lighter than air. Therefore, it is best to install the detector at table top level rather than on the ceiling like a smoke detector.

CO detectors are very sensitive and may sound an alarm for fumes other than CO or CO from sources other than the stove such as car or lawn mower exhaust.

If the alarm sounds

1. Increase ventilation by opening windows or doors.
2. Make sure the stove doors and lid are closed and latched.
3. Check stove for smoking or puffing condition. Open by-pass and increase air-flow to firebox, if needed.
4. Check chimney for possible blockage or down-draft.
5. Check for false alarm.

SAFETY NOTICE: IF THIS APPLIANCE IS NOT PROPERLY INSTALLED, OPERATED AND MAINTAINED, A HOUSE FIRE MAY RESULT. FOR YOUR SAFETY, FOLLOW INSTALLATION DIRECTIONS. CONTACT LOCAL BUILDING OR FIRE OFFICIALS ABOUT RESTRICTIONS AND INSTALLATION INSPECTION REQUIREMENTS IN YOUR AREA.

CAUTION

WHEN THIS ROOM HEATER IS NOT PROPERLY INSTALLED, A HOUSE FIRE MAY RESULT. TO REDUCE THE RISK OF FIRE, FOLLOW THE INSTALLATION INSTRUCTIONS. CONTACT LOCAL BUILDING OR FIRE OFFICIALS ABOUT RESTRICTIONS AND INSTALLATION INSPECTION REQUIREMENTS IN YOUR AREA.

WARNING

NEVER USE GASOLINE, LANTERN FUEL, KEROSENE, CHARCOAL LIGHTER FLUID, OR SIMILAR LIQUIDS TO START OR "FRESHEN UP" A FIRE IN THIS HEATER. KEEP ALL SUCH LIQUIDS WELL AWAY FROM THE HEATER WHILE IT IS IN USE.

WARNING

NEVER CONNECT THIS UNIT TO A CHIMNEY FLUE SERVING ANOTHER APPLIANCE.

WARNING

DO NOT CONNECT TO ANY AIR DISTRIBUTION DUCT OR SYSTEM.

WARNING

THIS WOOD HEATER HAS A MANUFACTURER-SET MINIMUM LOW BURN RATE THAT MUST NOT BE ALTERED. IT IS AGAINST FEDERAL REGULATIONS TO ALTER THIS SETTING OR OTHERWISE OPERATE THIS WOOD HEATER IN A MANNER INCONSISTENT WITH OPERATING INSTRUCTIONS IN THIS MANUAL.

WARNING

BURNING COLORED PAPER, CARDBOARD, SOLVENTS, TRASH AND GARBAGE OR ALTERING THE STOVE FOR HIGHER HEAT OUTPUT MAY CAUSE DAMAGE TO THE STOVE AND COULD RESULT IN A HOUSE FIRE. USE ONLY APPROVED FUELS AND FOLLOW ONLY THESE OPERATION GUIDELINES.

NOTICE

Due to ash buildup, it is strongly recommended to have your stove professionally cleaned and serviced annually. This includes all parts of the stove, and the venting system.

Installation and repair of this stove should be done by a qualified service person. We recommend that the stove be inspected before use and at least annually by a qualified service person. Periodic cleaning is required throughout the heating season and at the end of each winter for the stove to work efficiently.

3 Getting Started

A. Design, Installation & Location Considerations

1. Appliance Location

Consideration must be given to safety, convenience, traffic flow, and the fact that the appliance will need a chimney and chimney connector. It is a good idea to plan your installation on paper, using exact measurements for clearances and floor protection, before actually beginning the installation. When installing on a combustible floor, the bottom heat shield must be installed along with using proper floor protection material. See Section 4C for details.

Maintain specified vent clearance to combustible requirements listed by the vent manufacturers instructions and all clearance to combustibles listed in this manual.

Check with your local building code agency before you begin your installation. Be sure local codes do not supersede UL specifications and always obtain the required permit so that insurance protection benefits cannot be unexpectedly cancelled. If any assistance is required during installation, please contact your dealer.

We recommend that a qualified building inspector and your insurance company representative review your plans before and after the installation.

Be sure to provide a source of fresh air to the room or directly to the appliance. Make-up air is needed to replace what the chimney draws away through the appliance.

 CAUTION
DO NOT CONNECT THIS UNIT TO A CHIMNEY FLUE SERVICING ANOTHER APPLIANCE.
DO NOT CONNECT TO ANY FORCED AIR DISTRIBUTION DUCT OR SYSTEM.

	Installation and service of this appliance should be performed by qualified personnel. Hearth & Home Technologies recommends HHT Factory Trained or NFI Certified professionals.
---	--

B. Fire Safety

Maintain the designated clearances to combustibles. Insulation must not touch the chimney. You must maintain the designated air space around the chimney. This space around a chimney is necessary to allow natural heat removal from the area. Insulation in this space will cause a heat buildup, which may ignite wood framing.



NOTE: Clearances may only be reduced by means approved by the regulatory authority having jurisdiction.

To provide reasonable fire safety, the following should be given serious consideration:

1. Install at least one smoke detector on each floor of your home. Detectors should be located away from the heating appliance and close to sleeping areas. Follow the smoke detector manufacturer's placement and installation instructions, and be sure to maintain regularly.
2. A conveniently located Class A fire extinguisher to contend with small fires resulting from burning embers.
3. A practiced evacuation plan, consisting of at least two escape routes.
4. A plan to deal with a chimney fire as follows:

In the event of a chimney fire:

- a. Evacuate the house immediately.
- b. Notify Fire Department.
- c. Never apply water to a suspected chimney fire. Serious damage could occur.

 WARNING	
	FIRE HAZARD
	DO NOT OPERATE APPLIANCE BEFORE READING AND UNDERSTANDING THE OPERATING INSTRUCTIONS.
	FAILURE TO OPERATE PROPERLY MAY CAUSE A HOUSE FIRE.

C. Component Locations

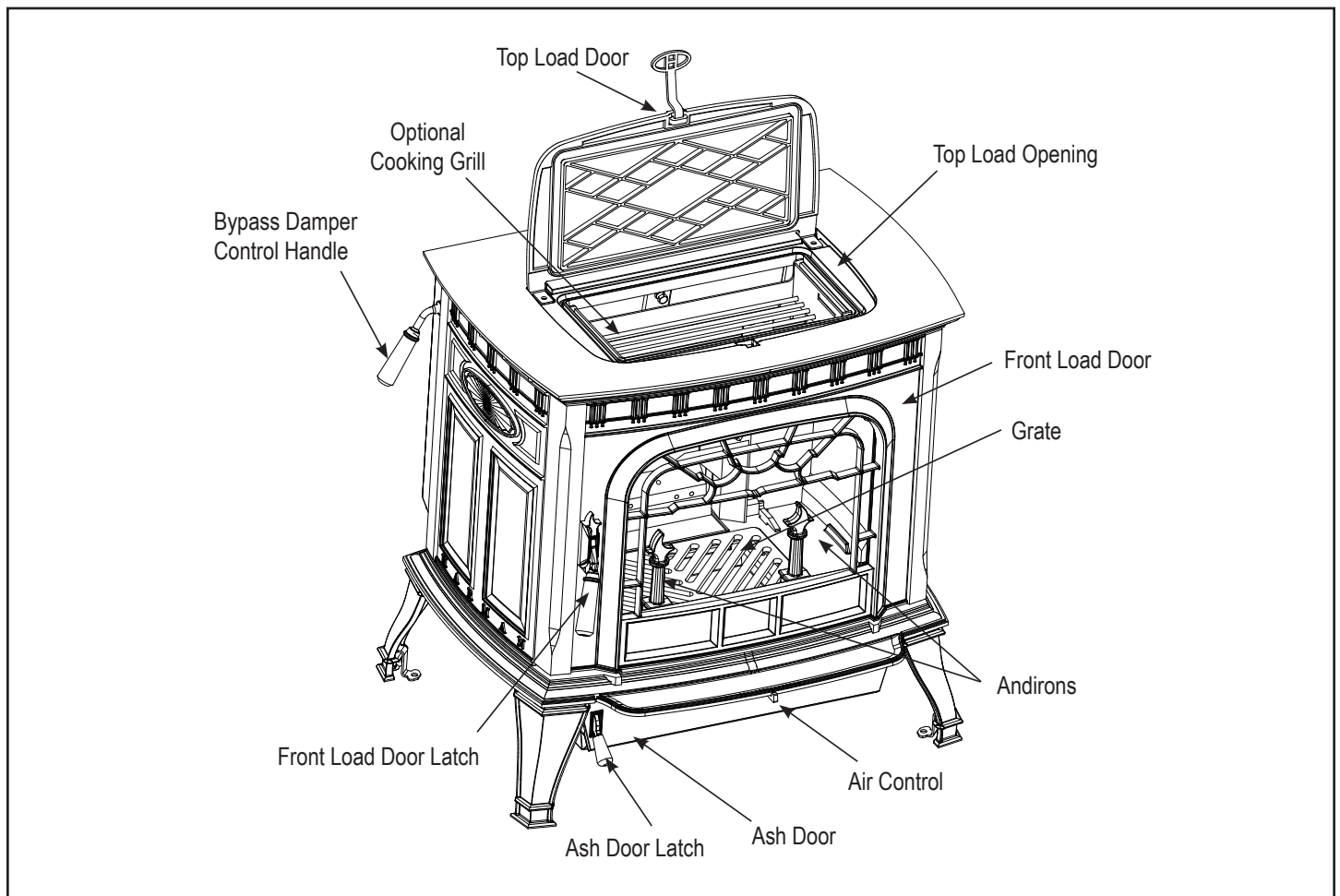

D. Flue Direction Conversion

The Oakwood features an adjustable flue collar for rear or top exit. Follow these instructions for changing the direction. First, remove the upper rear heat shield by removing 8 Tek screws that secure it. Reaching upward through the firebox and the open bypass damper, loosen the retainer bolts on each of the flue collar and the cast iron plate. With the bolts loosened, turn the retainer to allow the piece to come free of the stove body. Reposition the flue collar and the cast iron plate and secure them with the retainers by tightening the bolts. You will now need to install a different upper rear heat shield. (See Section 7E).

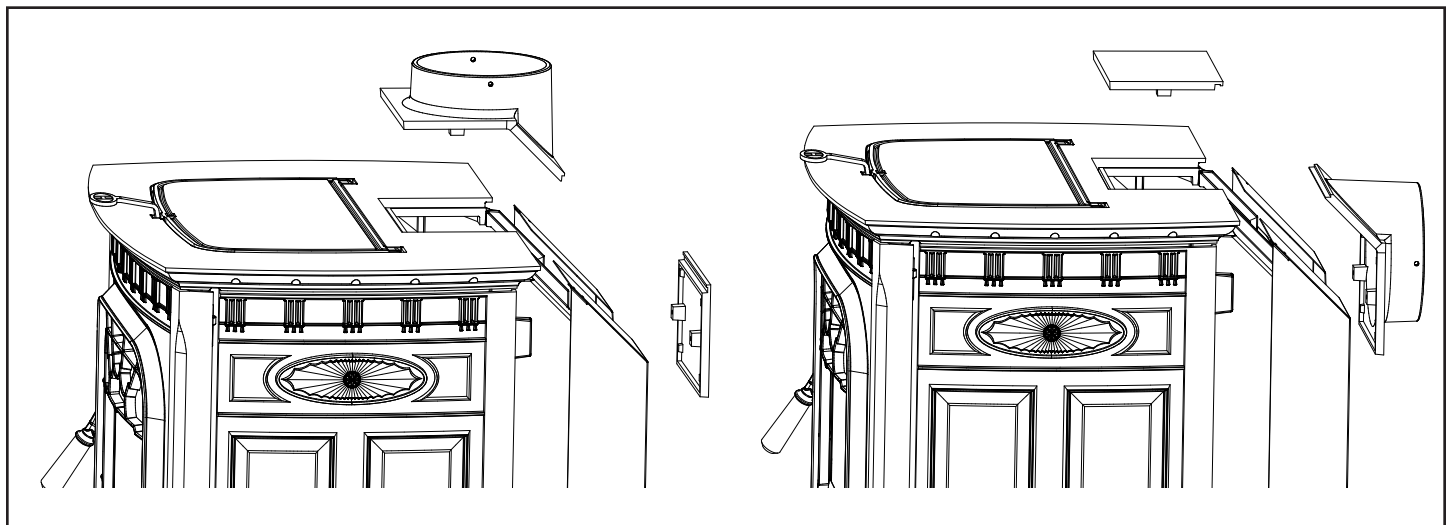

E. Pre- Use Check List

1	Place the appliance in a location near the final installation and follow the procedures below:
2	Open the appliance and remove all articles packed inside. Inspect all items for shipping damage. Notify dealer of any missing or damaged goods.
3	All safety warnings have been read and followed precisely.
4	This Owner's Manual has been read in it's entirety.
5	Floor protection requirements have been read and followed.
6	The flue connector has been installed in accordance with the instructions herein.
7	The proper clearances from the appliance and chimney connector to combustibles have been met.
8	The masonry chimney has been cleaned and inspected by a professional, or the factory built metal chimney is installed according to the manufacturers instructions.
9	The chimney meets the minimum height requirements.
10	All labels and hang tags have been removed from the glass.
11	All plated surfaces have been wiped clean, if applicable.

⚠ WARNING

INSPECT APPLIANCE AND COMPONENTS FOR DAMAGE. DAMAGED PARTS MAY IMPAIR SAFE OPERATION.

- DO NOT INSTALL DAMAGED COMPONENTS.
- DO NOT INSTALL INCOMPLETE COMPONENTS.
- DO NOT INSTALL SUBSTITUTE COMPONENTS.

REPORT DAMAGED PARTS TO DEALER.

⚠ WARNING

FIRE RISK.
HEARTH & HOME TECHNOLOGIES DISCLAIMS ANY RESPONSIBILITY FOR, AND THE WARRANTY WILL BE VOIDED BY, THE FOLLOWING ACTIONS:

- INSTALLATION AND USE OF ANY DAMAGED APPLIANCE.
- MODIFICATION OF THE APPLIANCE.
- INSTALLATION OTHER THAN AS INSTRUCTED BY HEARTH & HOME TECHNOLOGIES.
- INSTALLATION OF PARTS OR COMPONENTS NOT SUPPLIED OR APPROVED BY HEARTH & HOME TECHNOLOGIES.
- OPERATING APPLIANCE WITHOUT THE LEGS ATTACHED.
- OPERATING APPLIANCE WITHOUT FULLY ASSEMBLING ALL COMPONENTS.
- DO NOT OVERFIRE.

OR ANY SUCH ACTION THAT MAY CAUSE A FIRE HAZARD.

There are two brick clips located in the Owner's manual bag. With the bricks in place, install the clips in the front corners as shown. The long portion of the clip will fit between the brick and the wall of the stove, with the short hook over-hanging to the inside of the firebox.

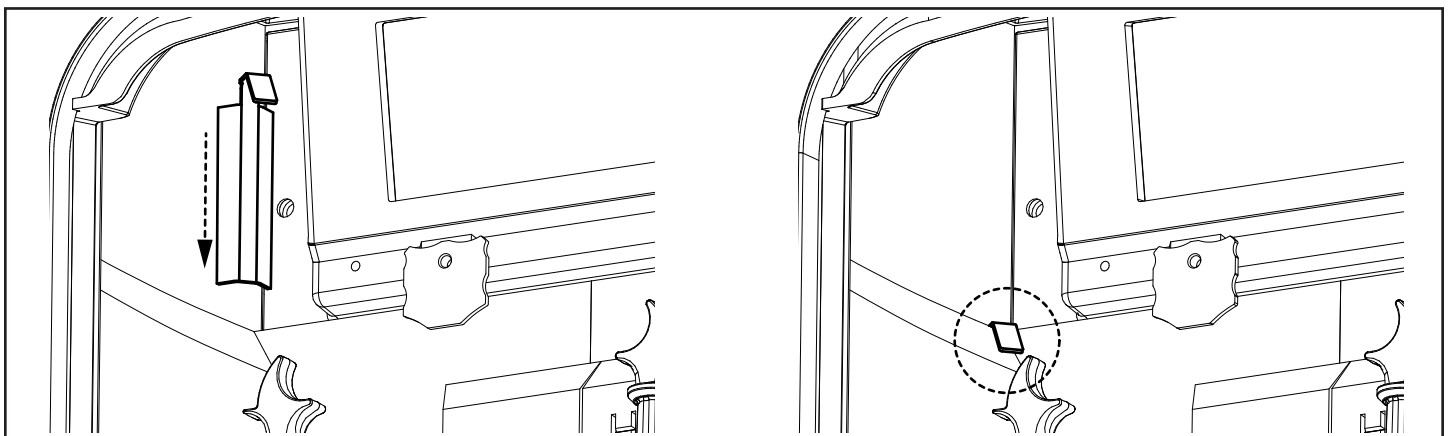

4 Dimensions & Clearances

A. Appliance Dimensions

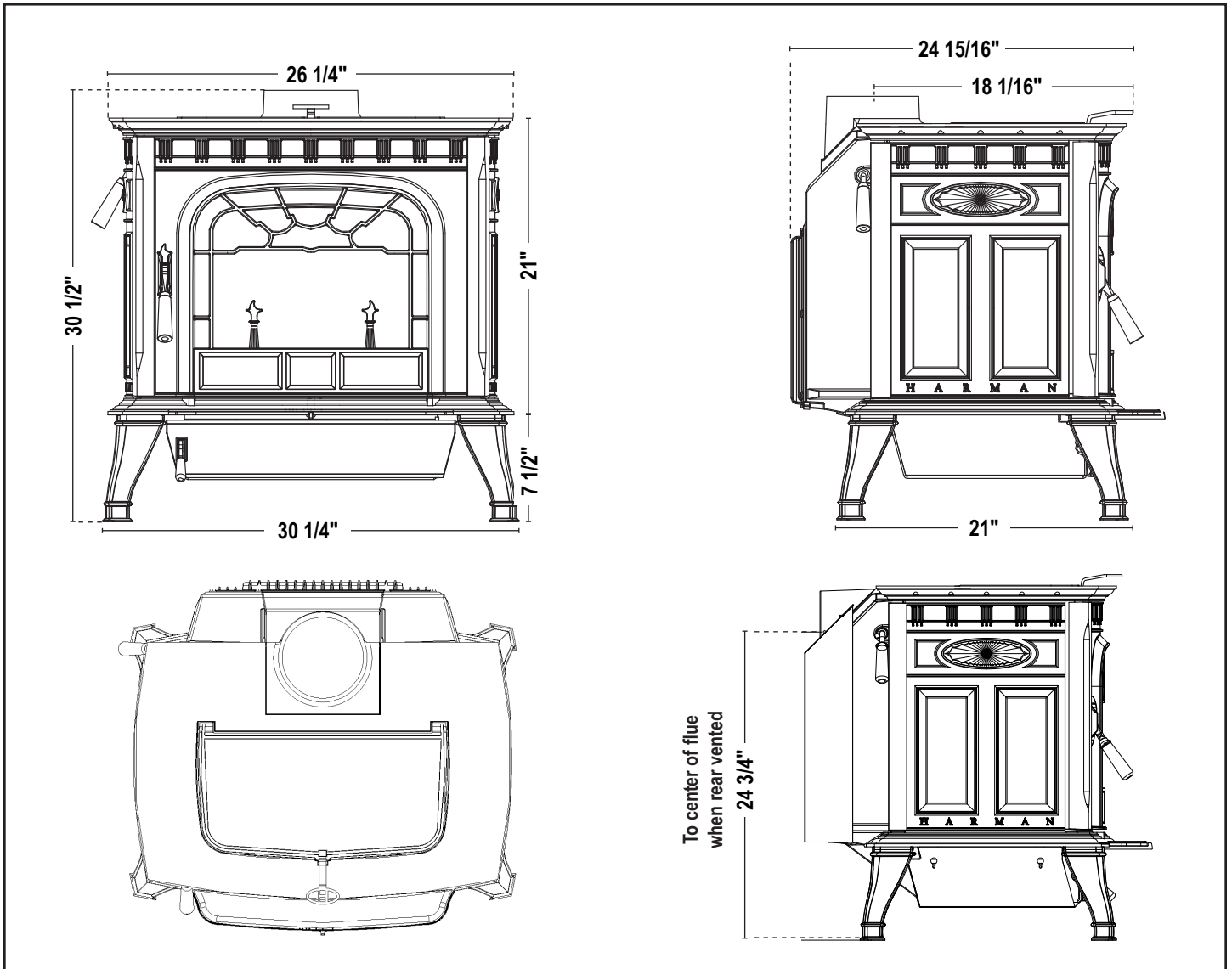

B. Clearances To Combustibles

Top Vent Installations - Without Rear Heat Shield			
Location		Single-Wall Chimney Connector	
Parallel Installation			
		Inches	Millimeters
A	Unit to Side Wall (Top Vent Through Ceiling)	26	660
B	Unit to Back Wall (Top Vent Through Ceiling)	28	711
C^{CL}	Chimney Connector Centerline to Side Wall	40	1016
D^{CL}	Chimney Connector Centerline to Back Wall	33	838
E	Unit to Side Wall (Horizontal Flue Exit From Room)	24	610
F	Unit to Back Wall (Horizontal Flue Exit From Room)	28	711
G	Chimney Connector to Ceiling	18	457
H	Minimum Vertical Run	24	610
I	Unit to Back Wall (Top Vent Out Back Wall with 90° Elbow)	28	711
J	Unit to Side Wall (Top Vent Out Back Wall with 90° Elbow)	24	610
Rear Shielding MUST BE Installed in order to use Double-Wall Chimney Connector			
Corner Installation			
K	Corner to Adjacent Wall	24	610
L	Chimney Connector Centerline to Adjacent Wall	34	864

Note: It is recommended that you have the unit in place for proper measurements and installation.

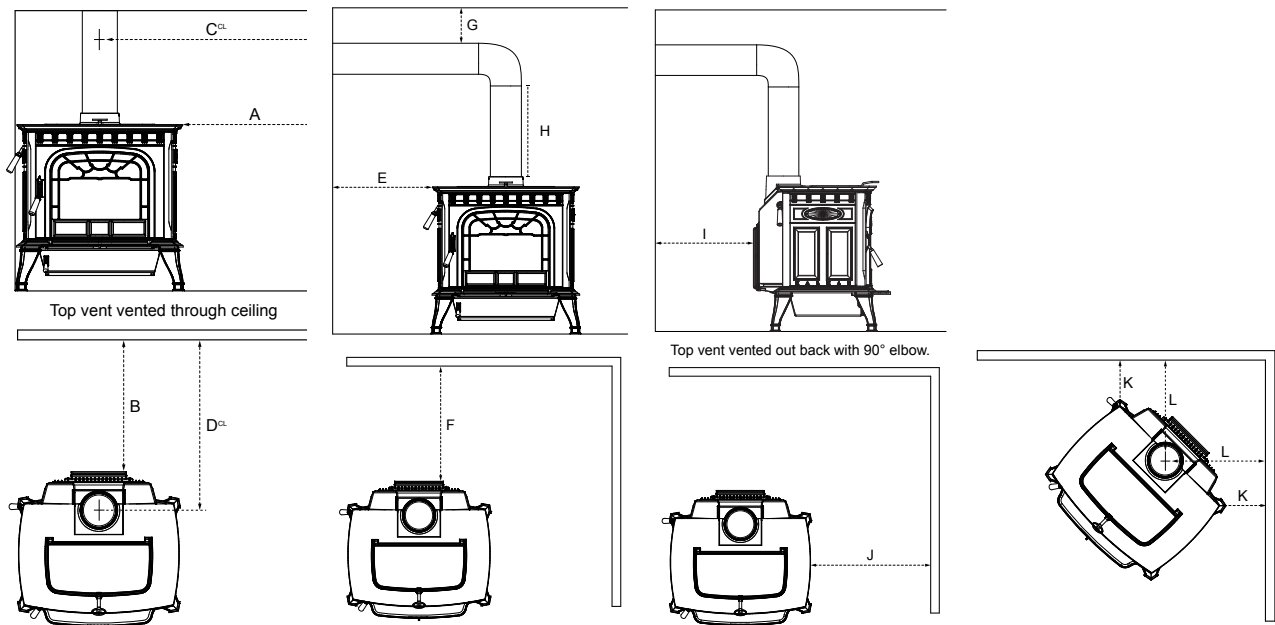

For clearance reduction methods, refer to NFPA 211 or Local Codes

Follow NFPA 211 Table 13.6.1 "Clearances for Solid Fuel-Burning Appliances" for clearance from the top of the unit to ceiling.

This unit was not tested for installation into an Alcove. Follow NFPA 211 Table 13.6.1 "Clearances for Solid Fuel-Burning Appliances".

Top Vent Installations - With Rear Heat Shield					
Location		Single-Wall Chimney Connector		Listed Double-Wall Chimney Connector	
Parallel Installation					
		Inches	Millimeters	Inches	Millimeters
A	Unit to Side Wall (Top Vent Through Ceiling)	26	660	22	559
B	Unit to Back Wall (Top Vent Through Ceiling)	19	483	13	330
C^{CL}	Chimney Connector Centerline to Side Wall	40	1016	36	914
D^{CL}	Chimney Connector Centerline to Back Wall	26	660	20	508
E	Unit to Side Wall (Horizontal Flue Exit From Room)	21	533	22	559
F	Unit to Back Wall (Horizontal Flue Exit From Room)	21	533	13	330
G	Chimney Connector to Ceiling	18	457	7	178
H	Minimum Vertical Run	24	610	24	610
I	Unit to Back Wall (Top Vent Out Back Wall with 90° Elbow)	21	533	13	330
J	Unit to Side Wall (Top Vent Out Back Wall with 90° Elbow)	21	533	22	559
Corner Installation					
K	Corner to Adjacent Wall	22	483	19	483
L	Chimney Connector Centerline to Adjacent Wall	32	813	29	737

Clearances will vary depending on the brand vent pipe being used.

Note: It is recommended that the unit be in place for proper measurements and installation.

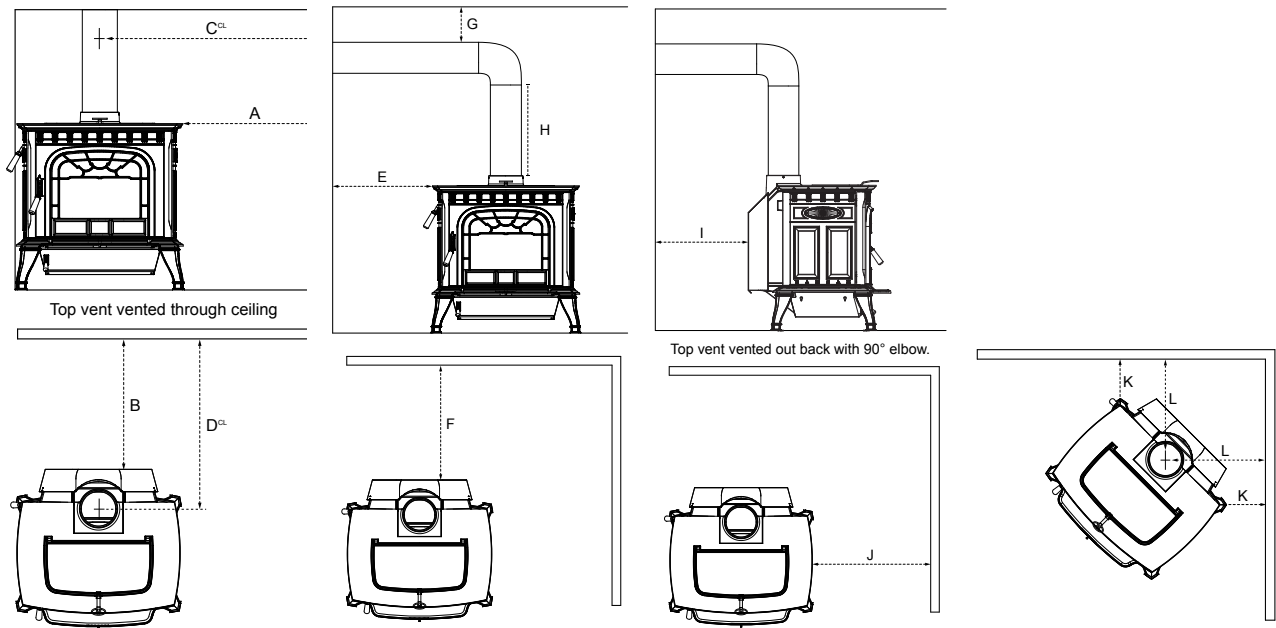

For clearance reduction methods, refer to NFPA 211 or Local Codes

Follow NFPA 211 Table 13.6.1 "Clearances for Solid Fuel-Burning Appliances" for clearance from the top of the unit to ceiling.

This unit was not tested for installation into an Alcove. Follow NFPA 211 Table 13.6.1 "Clearances for Solid Fuel-Burning Appliances".

Rear Vent Installations - With Rear Heat Shield			
	Location	Listed Double-Wall Chimney Connector	
Parallel Installation - With Rear Heat Shield			
		Inches	Millimeters
A	Unit to Side Wall (Vented out Ceiling with (1) 90° Elbow)	22	559
A	Unit to Side Wall (Vented out Back Wall with (2) 90° Elbows)	20	508
B	Unit to Back Wall (Vented Straight out Back Wall)	10	254
B	Unit to Back Wall	26	660
*C^{CL}	Chimney Connector Centerline to Side Wall	N/A	N/A
*D^{CL}	Chimney Connector Centerline to Back Wall	N/A	N/A
E	Chimney Connector to Ceiling	7	178
F	Minimum Vertical Run	24	610
Rear Shielding MUST BE Installed in order to use Double-Wall Chimney Connector			
Corner Installation - With Rear Heat Shield			
G	Corner to Adjacent Wall (Vented with 45° Elbow out Side Wall)	16	406

*Clearances will vary depending on the brand vent pipe being used.

Note: It is recommended that the unit be in place for proper measurements and installation.

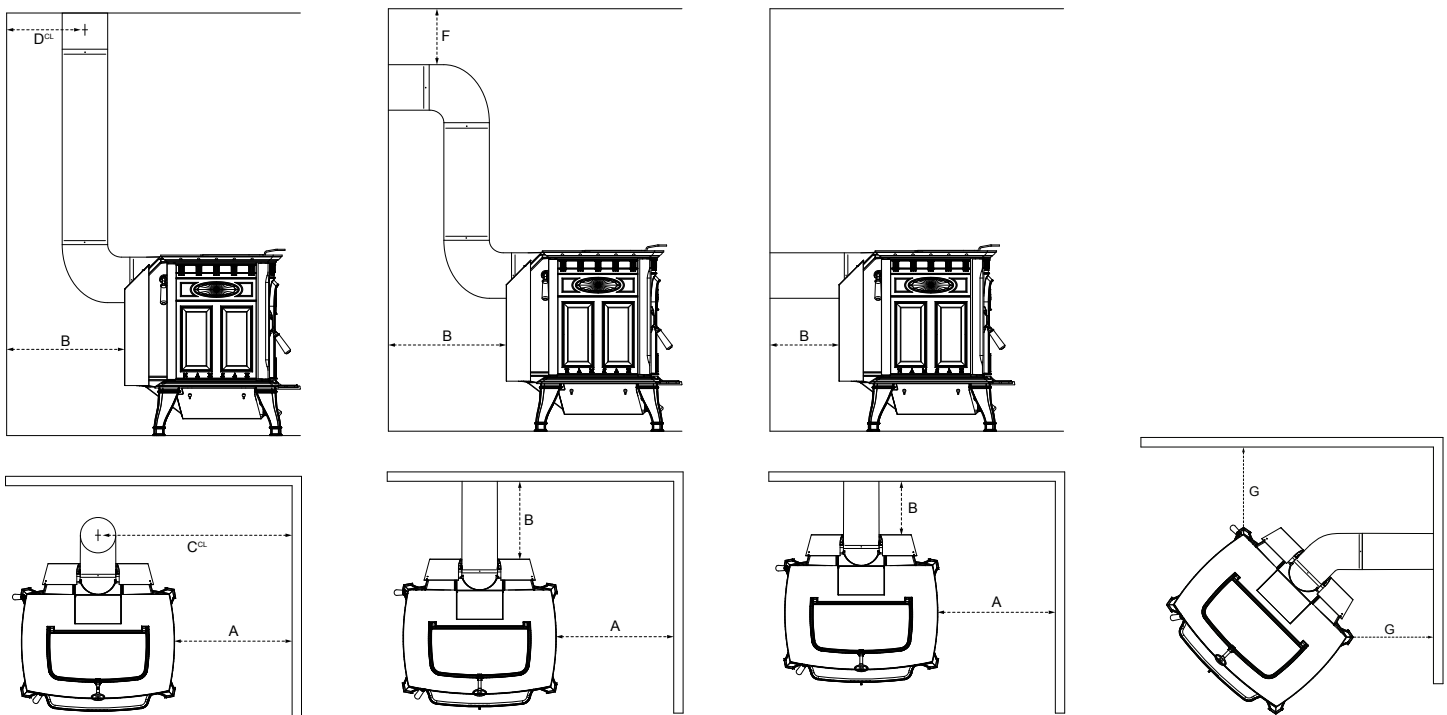

For clearance reduction methods, refer to NFPA 211 or Local Codes

Follow NFPA 211 Table 13.6.1 "Clearances for Solid Fuel-Burning Appliances" for clearance from the top of the unit to ceiling.

This unit was not tested for installation into an Alcove. Follow NFPA 211 Table 13.6.1 "Clearances for Solid Fuel-Burning Appliances".

Fireplace Insert Installation - Rear Flue - 6" Single Wall Pipe

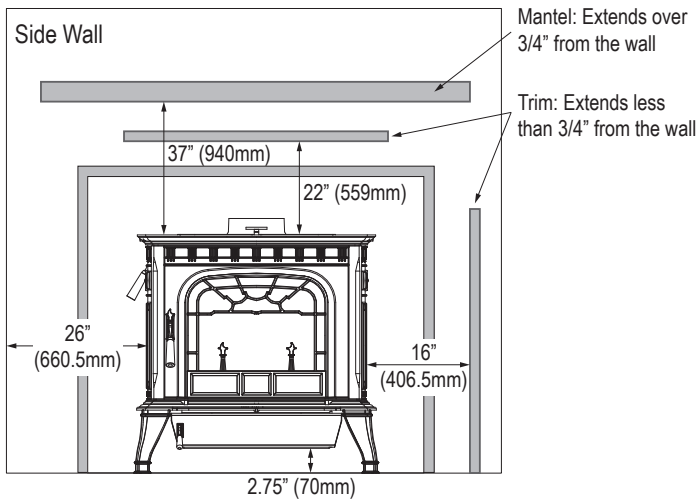

NOTICE: Not for use in factory built fireplaces with hearth weight limitations.

The Oakwood should not be installed into a factory built fireplace unless the hearth area is designed to take the maximum weight of the stove. The Oakwood, loaded with wood weighs approximately 500 pounds (250kg).

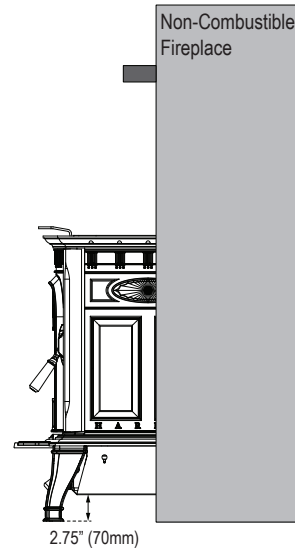

If the fireplace floor can hold the 500 lb. (250 kg) Oakwood, the stove should only be placed into the fireplace opening to the point that operation of the damper bypass control and the top load door operation is not compromised or unsafe. (See above illustration.)

Installing in front of a fireplace with Mantel

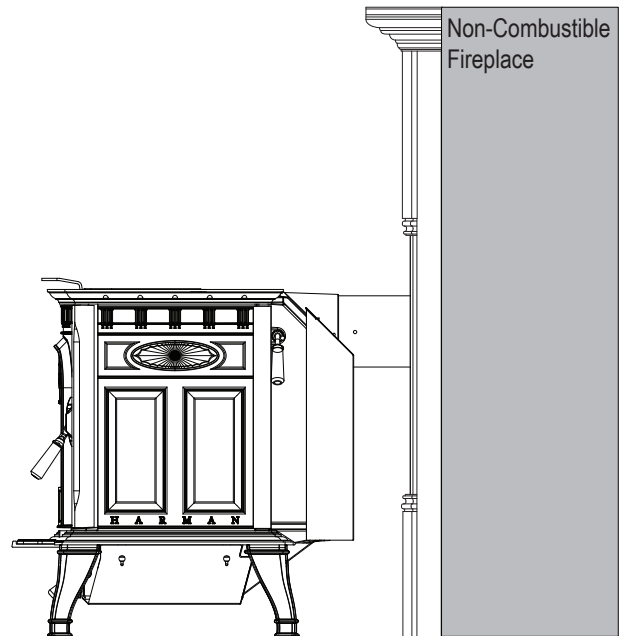
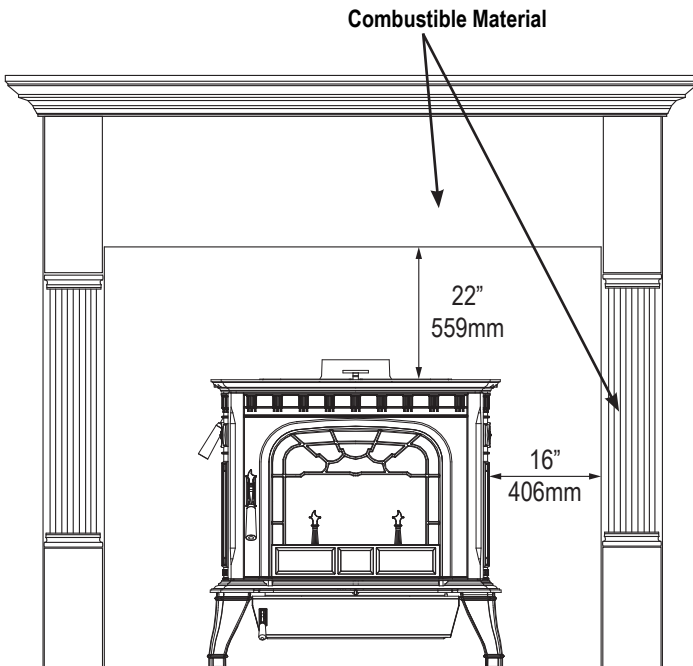

C. Floor Protection Requirements

Floor Protection Requirements

The Oakwood must be installed on a non-combustible surface or a protective non-combustible floor. It is recommended that the heat shield provided be installed. Using the provided heat shield will allow for installation of floor protection without a "R" or "K" value. If you do not use the bottom heat shield floor must be at least 3/4 "(19 mm) thickness of insulating material having a value equal to or greater than 0.84k/in. (More the value of k, the better the protection.)

Another method for calculating floor protection is in R value. This requirement would be for an R value of 0.89 or higher. (The higher the R value, the better the protection.)

In all installations, the area under and around the stove must be protected from falling ash and live coals. *The area under a horizontal run of chimney connector must also be protected, extending two (2) inches beyond the measurement of the horizontal connector.*

Further guidelines for floor protection are as follows:

In the U.S. the floor protector must be completely under the stove, and extending 18" in front of the door opening, 8" to each side and 8" to the back.

In Canada, the floor protection must extend 18" (457mm) in front of the door opening, 8" (203mm) to each side and extend to the wall behind the stove.

Minimum Size floor protection (USA) is 49-7/16" Deep by 34-11/16" Wide.

Floor protection touching the wall: 69-7/16" Deep x 58-3/8" Wide.

Floor Protection Requirements		US	Canada
J	Sides	8"	203mm
K	Front	18"	457mm
L	Rear	8"	203mm

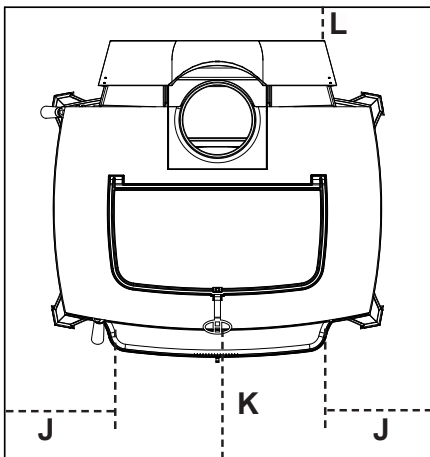

Type II floor protection must be used.

*Floor protection for the front and sides as measured from the appliance door opening.

DANGER: The appliance legs may not be removed for installation.

Parallel versus Corner Installations

A parallel installation is one in which the back and sides of the stove are parallel to the walls behind and to the side of the stove. A corner installation is one in which the back of the stove is positioned diagonally across a corner of the room. Each installation requires its own set of clearances.

For parallel installations, the required clearance distances from the stove are: (see next pages for more details, including the use of double walled pipe and optional heat shields)

1. to the side wall, 26" (661 mm);
2. to the back wall, 28" (712 mm).
3. From the flue connector to the wall, 33" (839mm)
4. Horizontal pipe to the ceiling, 15"(381 mm).

NOTE: For a vertical chimney connector in a parallel installation the distance of the connector to the side wall must be 32" (813 mm), due to the required side clearance of the stove itself. Fireplace installations must meet these same clearance requirements; specifically follow these guidelines for mantel and trim clearances.

For corner installations, the clearance distances are 24"(609 mm) from each corner of the stove measured straight back to the nearest combustible material, and 32" (813 mm) from the chimney connector to the walls. To stay within these clearances and have the floor protector touch the interior wall it must be a hearth pad size of 65" x 65" (USA ONLY).

From the front of the stove, clearance to combustible materials such as furniture, curtains, fuel, etc., is: 48" (1220 mm) in the U.S. and 60" (1524 mm) in Canada.

Alternate floor protector dimension may be used as long as they satisfy the measurement requirements shown.

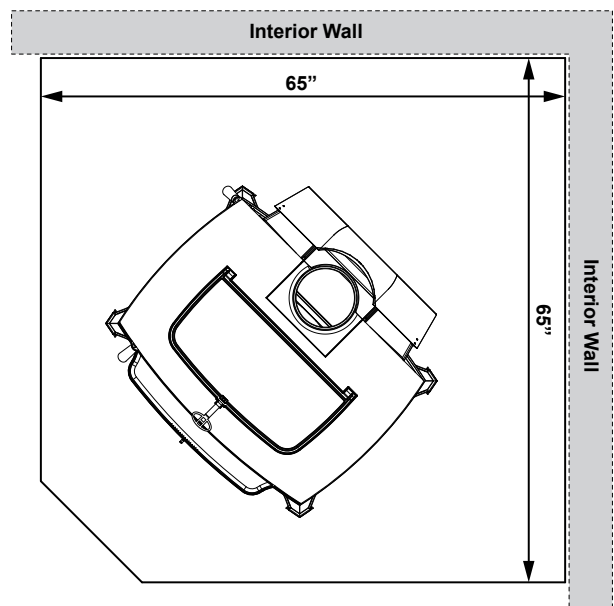

A. Draft

Draft is widely misunderstood. It is important that you, the stove operator, realize that draft is a variable *effect*, not a given quantity. Stoves and chimneys do not *have* draft, yet draft is the key to your stove's performance.

Draft is a *force*, produced by an operating stove and the chimney to which it is attached. It is created by hot gases rising up the chimney, creating a pressure difference between the inside of your home and the outside air. It continually moves fresh combustion air into the stove, and hot exhaust gases out of the stove; without this constant flow, the fire will go out.

Other factors, such as barometric pressure, winds, the airtightness of the home, the total inside chimney volume, chimney height and the presence of venting devices such as exhaust fans also play a role in maintaining an adequate draft. Low barometric pressures, super insulated homes and exhaust fans can reduce draft; winds can play havoc with draft; and too large or too small a chimney volume can cause reduced draft due to the excessive cooling or not enough room to vent exhaust gases. Introducing outside air directly to the stove may help remedy a low draft problem. Some signs of inadequate draft are smoking, odor, difficulty in maintaining the fire, and low heat output. Overdraft can be caused by a very tall chimney even if it is the recommended size, and can cause overfiring of your stove. Signs of an overdraft include rapid fuel consumption, inability to slow the fire, and parts of the stove or chimney connector glowing red. It is important that you follow the chimney guidelines in this manual, including size, type, and height to avoid draft problems.

When installed and operated according to this manual, the Oakwood will produce enough hot gases to keep the chimney warm so that adequate draft is maintained throughout the burn cycle.

B. Chimney Connectors

In general, following these guidelines will ensure compliance with all national and provincial codes; prior to beginning your installation, check with your local building code official to check on additional local regulations which may influence the design and placement of your venting system.

The Harman Oakwood may be installed with a minimum (.6mm) 24 gauge chimney connector pipe. The size of the connector should correspond to the size of the flue collar opening. Do not use makeshift compromises. No part of the chimney connector may pass through an attic or roof space, closet or other concealed space, or through a floor or ceiling. Whenever possible, avoid passing the connector through a combustible wall; if you must, use an approved wall pass-through, described later in this section.

Assemble the connector beginning at the flue collar, with the crimped ends pointing towards the stove (to keep debris or residue inside the system). Each joint, including the one to the stove's flue collar and the one to the chimney itself should be secured with at least three sheet metal screws. Screws may be a maximum of 3 inches apart. A 1-1/4" (30mm) overlap is required at each joint, including the flue collar attachment. No more than two 90° elbows should be used, and the total length of connector should not exceed 10 feet (3m). All horizontal runs of connector must have a minimum upward slope of 1/4" (6mm) per foot (20mm per meter).

The chimney connector diameter should correspond to the size of the flue collar opening. Do not use makeshift compromises. No part of the chimney connector may pass through an attic or roof cemented in place with refractory cement.

C. Wall Pass-throughs

Depending on your local building codes, and the pertinent provincial or national codes, there are several choices for passing the chimney connector safely through a wall. Before beginning your installation, contact local officials, and also the chimney connector and chimney manufacturer for specific requirements.

Canada. Three methods are approved by the Canadian Standards Association. The diagram on the next page shows one method requiring an 18" (450mm) air space between the connector and the wall. It allows use of one or two covers as described in the diagram. The two other methods are described in detail in the current issue of CAN/CSA B365, the national standard.

United States In the U.S., the national code is NFPA 211. While many localities adopt this standard, be sure to check with local authorities before beginning your installation.

The NFPA (National Fire Protection Agency) permits four methods for passing through a combustible wall. A commonly used method to pass through a wall directly to a masonry chimney is to clear a minimum 12" (300mm) around the entire chimney connector, and fill it with brick masonry which is at least 3.5" (90mm) thick. A fireclay liner, minimum 3/8" (9mm) wall thickness must run through the brick wall to the chimney liner (but not beyond the inner surface of the liner). It must be cemented in place with refractory cement. This method is illustrated on the next page. For details on the other three options, refer to the most recent edition of the NFPA 211 code.

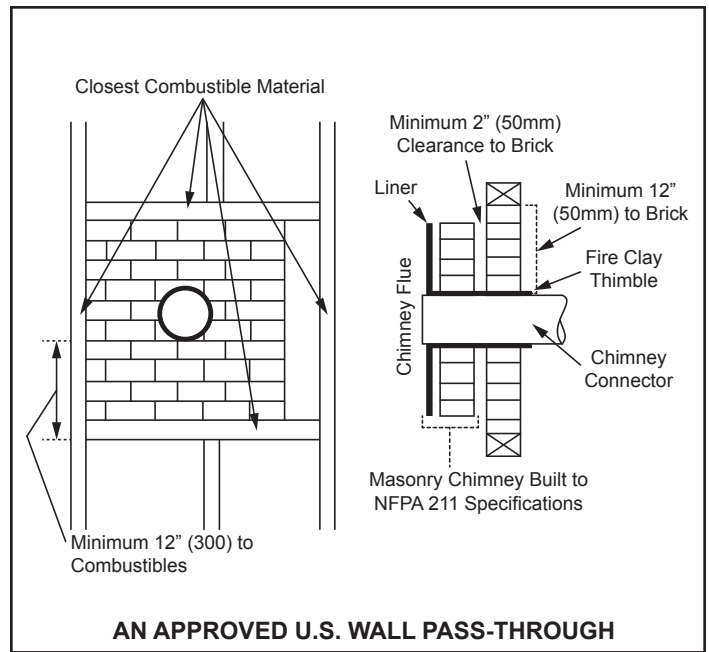
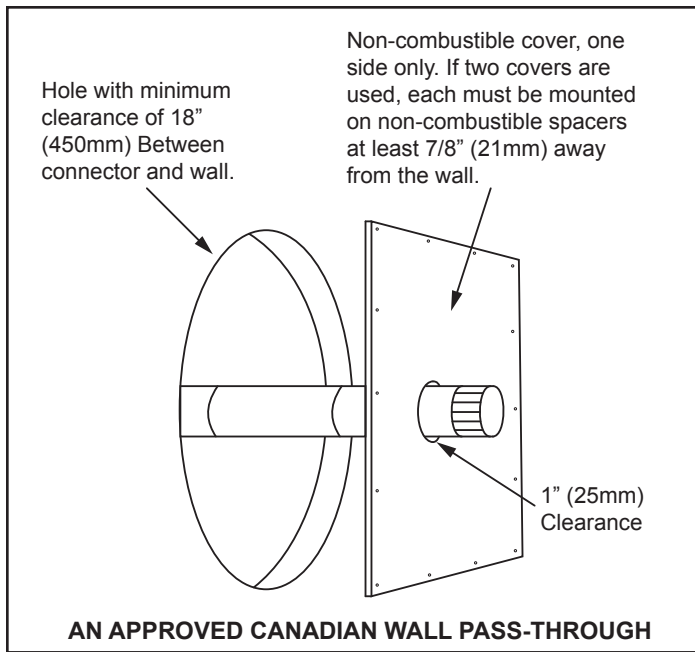

D. The Chimney

This unit must be installed into a chimney approved for use with solid-fuel appliances. In the U.S., it must be connected to (1) a prefabricated chimney complying with the requirements for Type HT chimneys in the Standard for Chimneys, Factory-Built, Residential Type and Building Heating Appliances, UL 103, or (2) a code-approved masonry chimney with a flue liner.

In Canada, this unit is listed for use with prefabricated chimneys tested and listed to the high temperature (650°C) chimney standard, ULC S-629, or with a code approved masonry chimney.

The minimum recommended height for any chimney is 16 ft. (4.8m) above flue collar height. For non-mobile home installations, a round flue (either masonry or approved prefabricated), of either 6" (150mm), 7" (180mm) or 8" (200 mm) may be used. For square or rectangular masonry chimneys, nominal sizes of 8" x 8" or 7" x 12" (200mm x 200mm, 180mm x 300mm) may be used.

Codes require that solid-fuel chimneys extend 3 ft. (0.9m) above the highest point at which they exit from the roof. Then, the chimney must extend 2 ft. (0.6m) above the highest point within a 10 ft (3m) radius. Thus, the 3 foot, 2 foot, 10 foot rule:

- 3ft.** - Above roof exit point
- 2ft.** - Higher than anything within-
- 10ft.** of the chimney.

Do not connect this unit to a chimney flue servicing another appliance.

NOTE: The restriction of not venting more than one appliance to the same flue applies to the U.S. specifically. While it is not recommended that you use the same chimney for more than one appliance, in *Canada* certain exceptions may be made. Be sure to contact your building code inspection official to see if this option is allowed in your area, and to find out the specific requirements for such an installation.

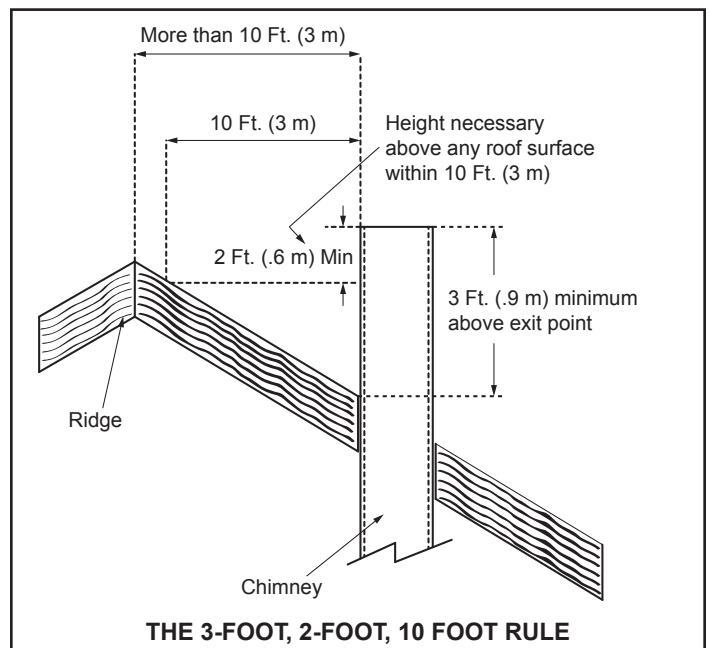

Existing Masonry Chimneys

If you plan on using a pre-existing masonry chimney, have it thoroughly inspected and cleaned. Any faults which make the chimney unsafe and unusable must be repaired prior to use. These can include improper height, structural defects, blockages, inadequate clearance to combustibles, unsealed openings into other rooms of the house, signs of creosote or smoke leakage, a loose or absent clean-out door, or absence of a liner.

Venting to a Masonry Chimney

When connecting to a masonry chimney, several provisions are standard. First, whether the chimney connector is vented to the chimney through a thimble or a breech pipe, neither must pass beyond the inner surface of the chimney liner, and both must be firmly cemented in place with refractory cement. (A thimble is a masonry pipe which is inserted through the chimney wall, and is frequently the preferred method; a breech pipe is a piece of steel pipe used the same way.) In Canada, a breech pipe has ridges or protrusions to lock it firmly into the refractory cement. In either case, the chimney connector vents to the chimney through the thimble or breech pipe.

Using a thimble, the connector slides completely inside the masonry to the inner edge of the flue liner, and may be easily removed for chimney and connector inspection. A breech pipe must extend at least 2" (50mm) into the room, so the connector can be attached with sheet metal screws.

Venting to a Masonry Fireplace Chimney

In some situations, a code compliant chimney originally used for a masonry fireplace may be used. In addition to the requirements found in the previous paragraphs, it is important to be aware that all clearances must be met, including those from the chimney connector to combustibles. Do not forget to include floor protection in your plans. (See Clearances and Floor Protection in this section.) Since many fireplaces have exposed wooden mantels and trim, pay special attention to the clearances necessary to these materials.

If your fireplace chimney is behind a combustible wall, you must use an approved wall pass-through system to gain access to the masonry chimney. The chimney connector must enter the chimney at a place where it is lined, and the fireplace must be made inoperable. For example, you might remove the damper, replacing it with a secure, airtight, noncombustible seal (removable for inspection); this also satisfies the requirement that no room air must be allowed to enter the chimney.

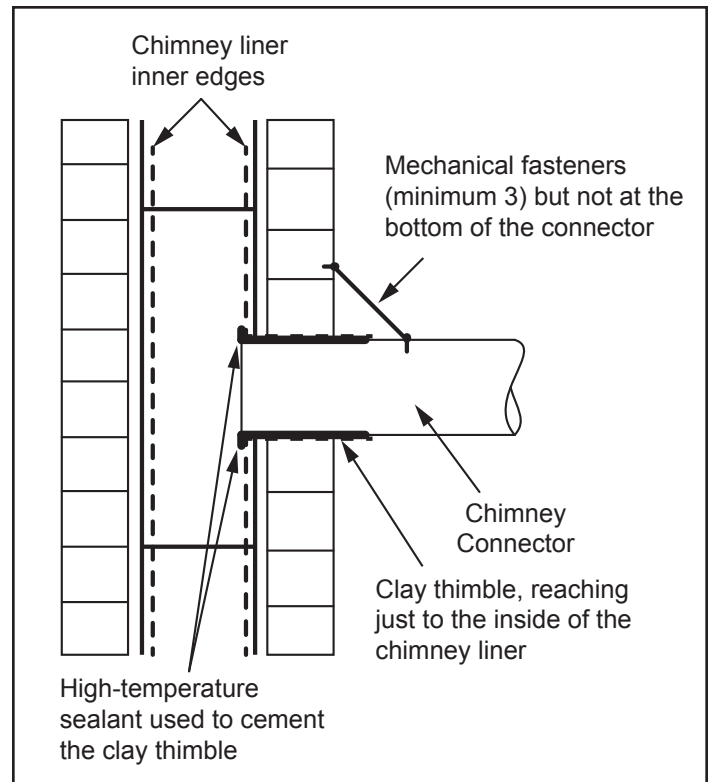

Installing to a Prefabricated Chimney

When venting using a prefabricated chimney, be sure to contact local building code authorities, and to follow the manufacturer's instructions *exactly*. Use only the manufacturer's parts; do not use makeshift installation techniques. All prefabricated chimneys must be tested to either the U.S. or Canadian high-temperature standards, UL 103 or ULC S629.

Other Considerations

Do not burn any fuel other than dry cordwood. Never use highly volatile substances in your stove, such as gasoline, which could cause an explosion.

When solid fuels are burned completely, they produce water and carbon dioxide. However, in long slow burns, a substantial amount of carbon monoxide may be produced. If allowed to build up, carbon monoxide (which is odorless) can prove fatally poisonous. Proper ventilation and draft will prevent this from happening. If you smell smoke, thoroughly ventilate your dwelling, and contact your dealer for service.

Other causes of poor ventilation or draft are icing, exhaust fans, a blocked outside air inlet, and room air starvation. If your stove is sluggish and you get occasional odor, check these possibilities and increase the air flow in your home.

**Standard Ceiling Installation with
Factory Built Chimney**

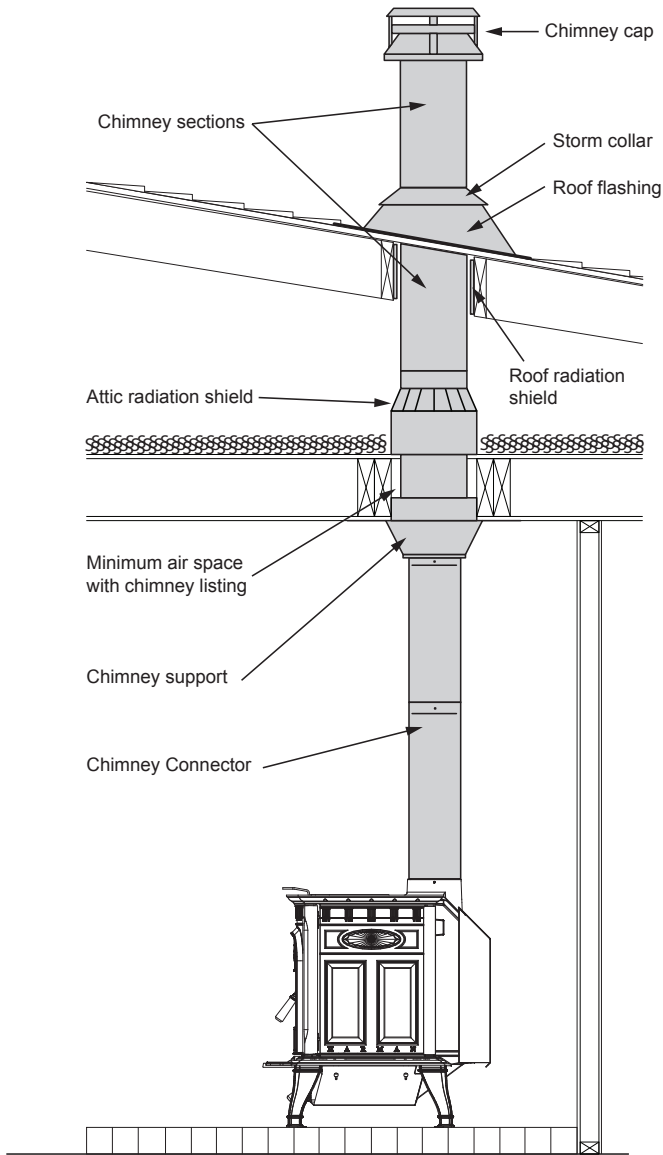

**Cathedral Ceiling Installation with
Factory Built Chimney**

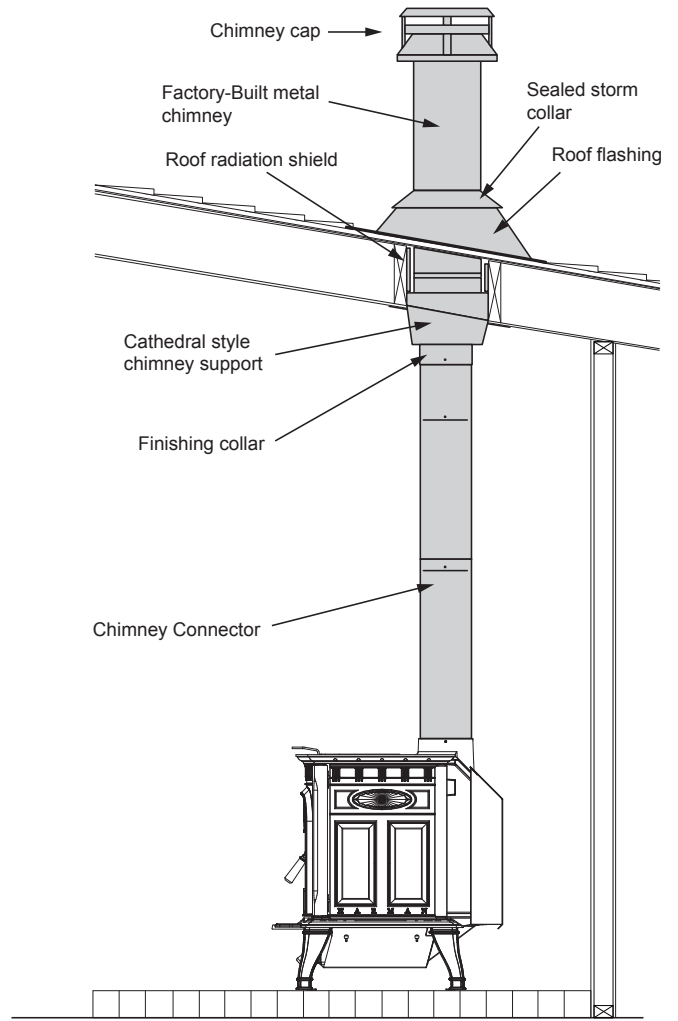

The Chimney Connector Shall Not Pass Through an Attic or Roof Space, Closet or Similar Concealed Space, a Floor or Ceiling.

Chimney Breach Fireplace Conversion with Non-Combustible Wall

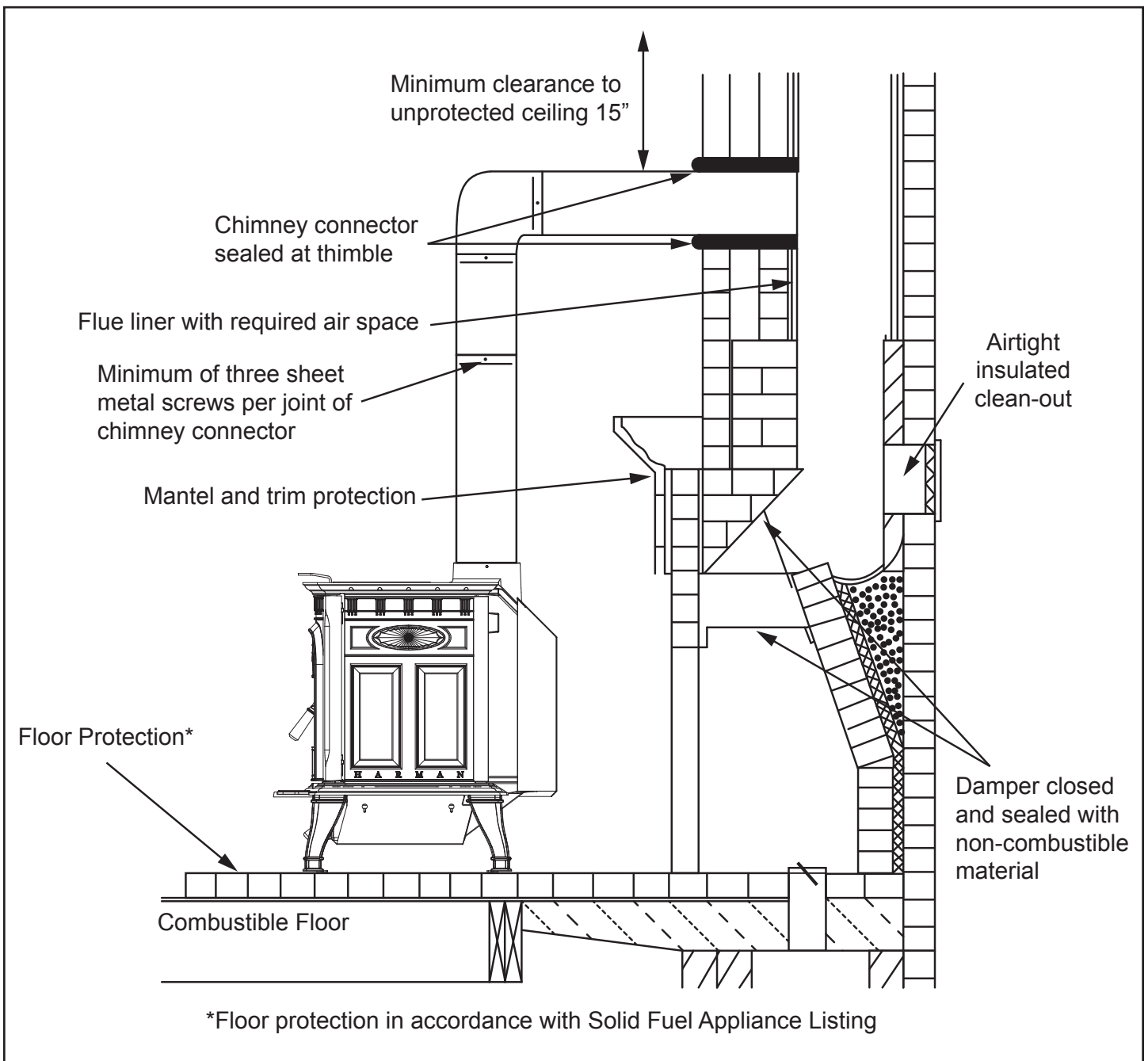

The Chimney Connector Shall Not Pass Through an Attic or Roof Space, Closet or Similar Concealed Space, a Floor or Ceiling.

Oakwood to Flue Fireplace Conversion (Minimum NFPA 211 Liner Connection)

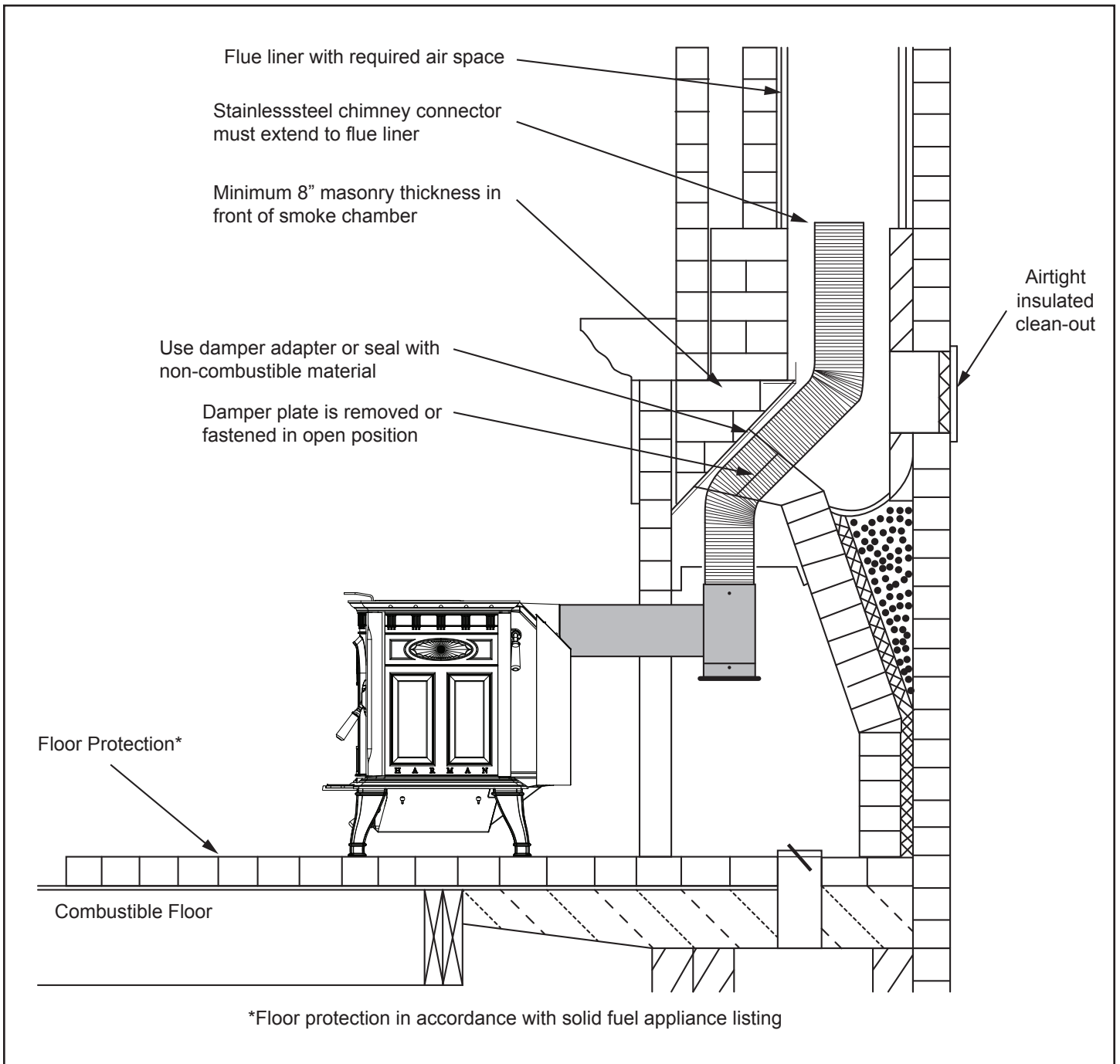

Full Relining Fireplace Conversion: Freestanding Appliance

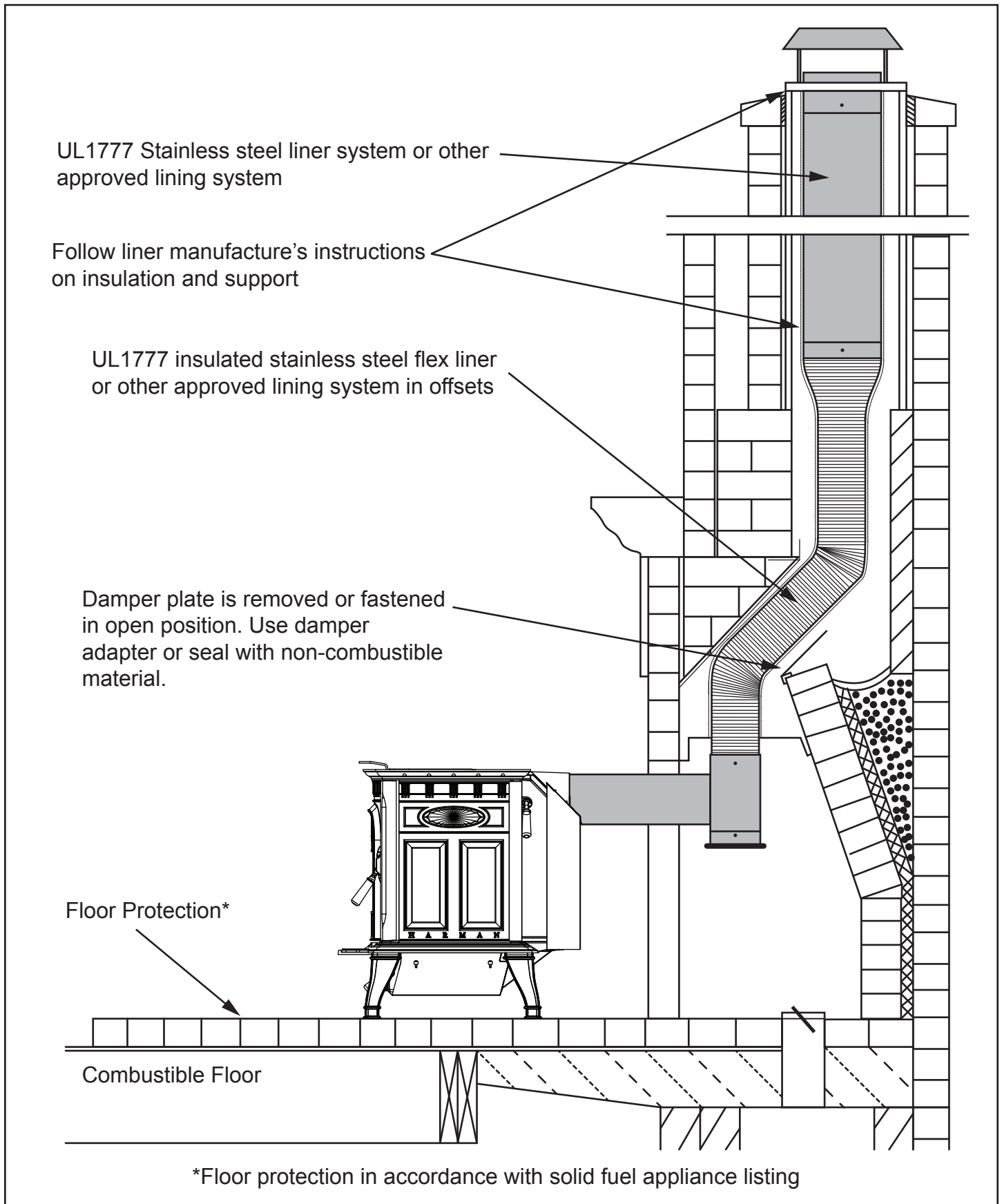

Chimney Breach Fireplace Conversion with Combustible Wall

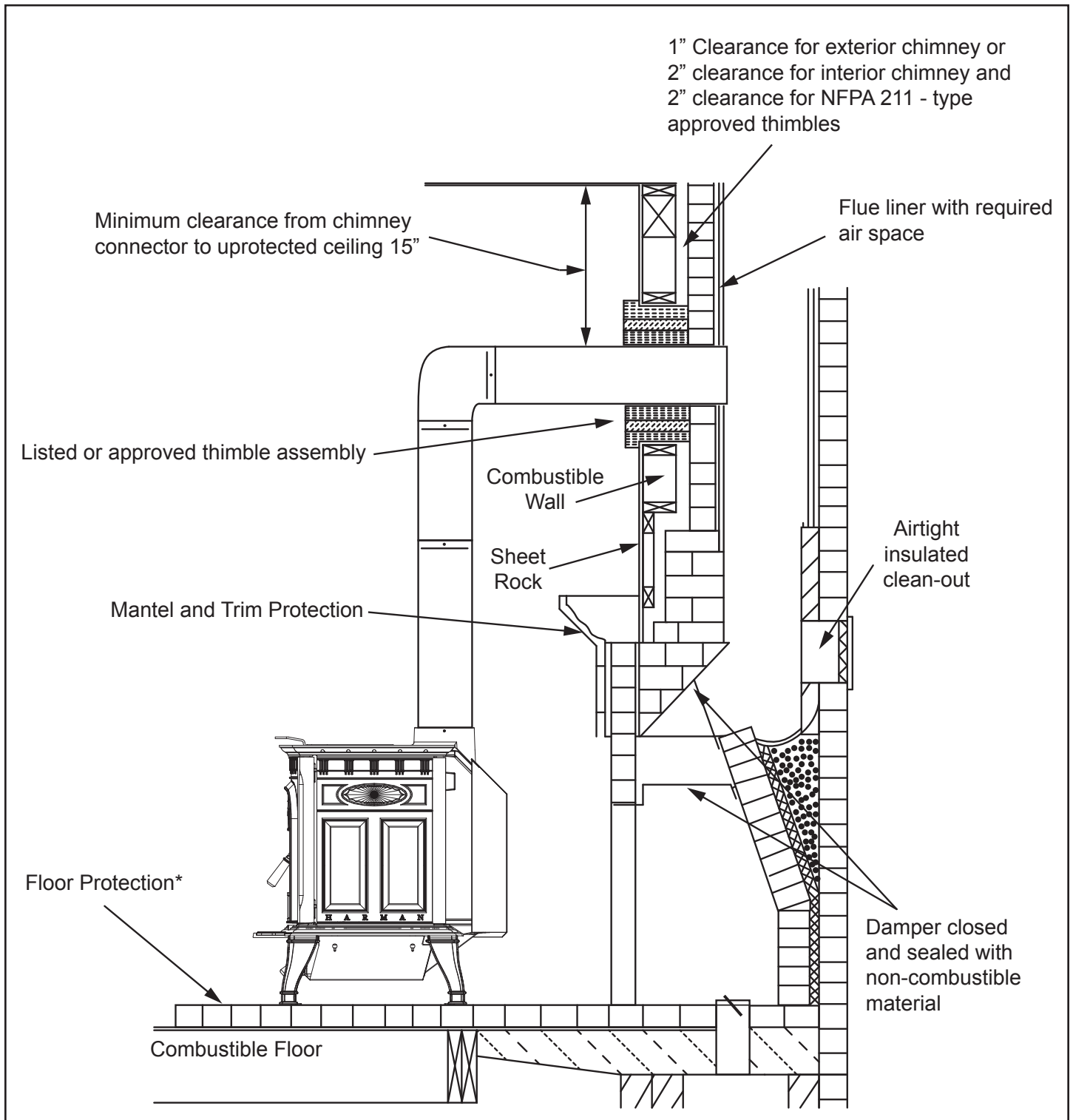

* Floor Protection in Accordance with Solid Fuel Appliance Listing

** Check with your local building codes for clearance.

7 Appliance Set-Up

A. Outside Air Attachment

Parts and Supplies Needed from Local Hardware Store: 1 piece of 4 in. (4.5 in. OD) aluminum flex dryer vent (4 in. rigid aluminum duct is not a suitable substitute and will not work) x needed length, 1 rodent screen, aluminum tape and a trim ring for finished around the outside air pipe inside the home.

1. Determine an appropriate hole location, through the wall. Be sure there are no studs or other supporting members. Also ensure there are no electrical wires or plumbing contained within the wall.
2. Make the hole through the exterior wall using a hole saw or reciprocating saw. You'll want the hole to be just slightly larger than the metal flex pipe.
3. Attach the rodent screen to one end of the flex pipe, and insert it through the wall until the back of the screen cover is against the outside surface.
4. Hold the flex pipe in place to make an accurate determination of the length needed. Cut the flex pipe to length.
5. Slide the trim ring onto the flex for the inside wall portion.
6. Slide the other end of the metal intake flex pipe into the stub on the rear of the Oakwood and secure it with aluminum tape. This air intake will supply outside air for the secondary combustion within the FireDome.
7. Secure the trim ring in place for finishing the inside wall area.
8. Seal around the rodent screen on the exterior wall, using silicone caulking.



CAUTION

NEVER DRAW OUTSIDE COMBUSTION AIR FROM:

- WALL, FLOOR OR CEILING CAVITY.
- ENCLOSED SPACE SUCH AS AN ATTIC OR GARAGE

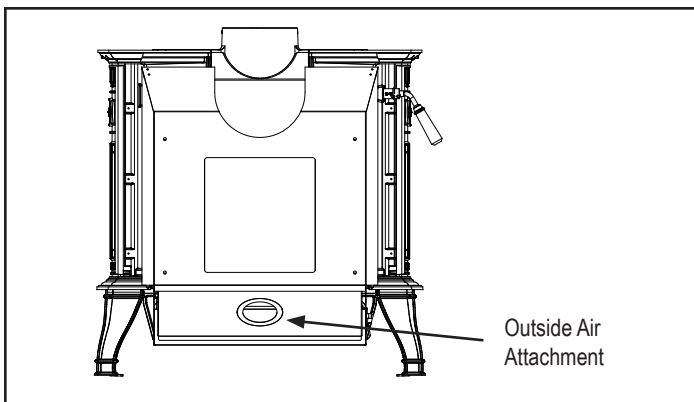

B. Leveling the Appliance

To adjust the leveling bolts, you must first loosen the locking nut. Turn the leveling bolt to the desired position, and tighten the locking nut against the cast iron leg.

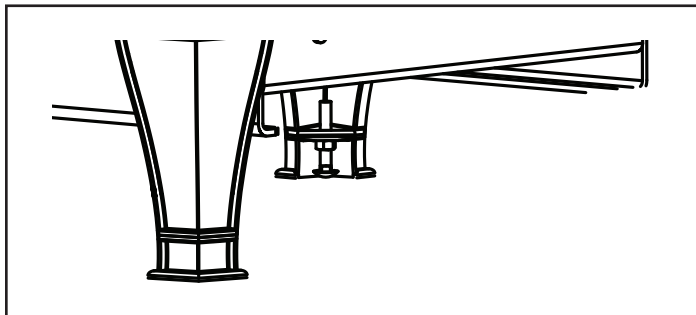

C. Optional Cooking Grill

The optional cooking grill #1-00-08121 installs easily in the top load opening of the Oakwood.

The grill handle (B) fits in the slots (C) on each side. To remove the handle, lower and turn.

When installed, the grill hangs in the opening by the hooks (A).

When grilling, you'll want to keep the fire size small and the bypass damper in the open position. Depending on the grilling being done, you may get grease dripping on the glass causing it to become dirty and obstructed. When you burn your next hot fire, the glass will likely clean itself.

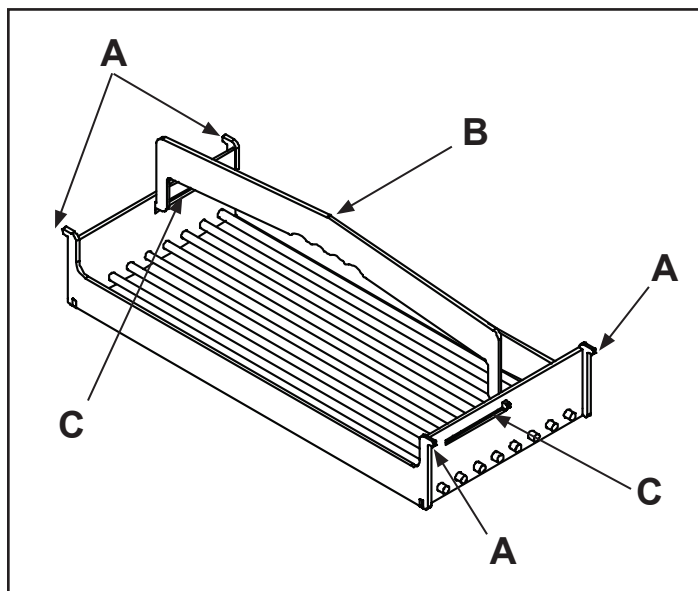

D. Optional Rear Shield

The rear heat shield, (Top Vent #1-00-02492 - Rear Vent #1-00-02493), will allow you to install your Oakwood closer to the wall. Please note there are two different shields based on whether the unit is rear or top vented.

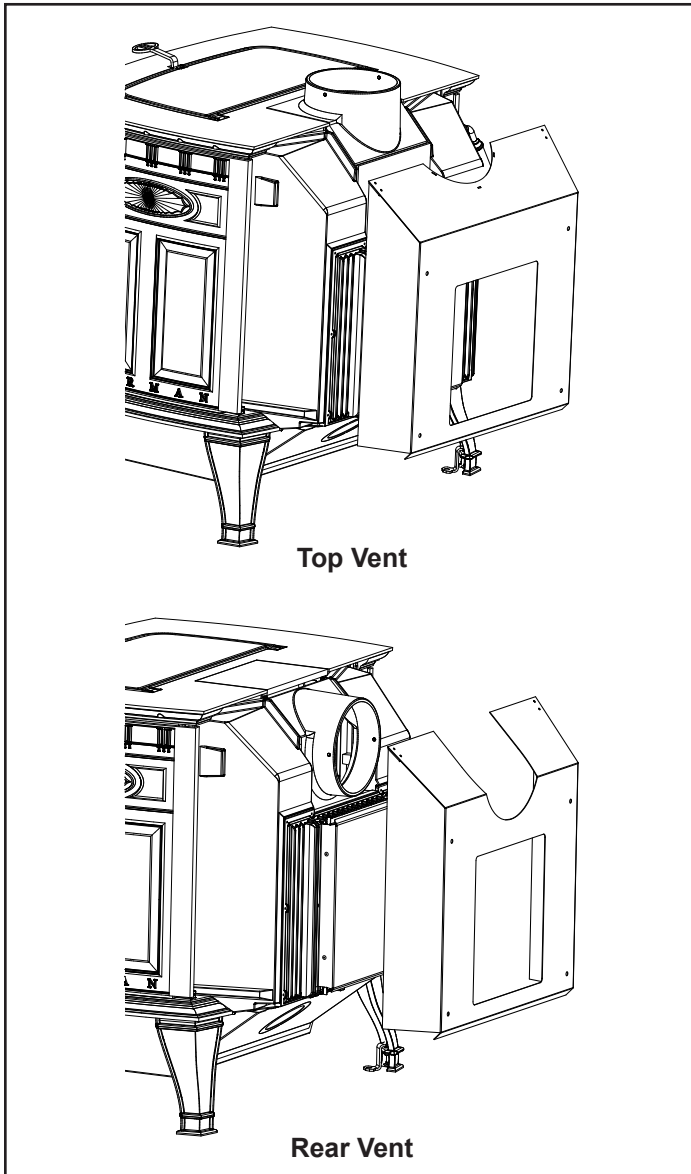

E. Bottom Heat Shield - Part #1-00-797058

Unless installed on unpainted concrete over bare earth, the bottom heat SHIELD MUST BE INSTALLED.

The heat shield installs on four tek screws that would be located at each side of the stove body. Start the tek screws into the wings loosely. From the rear, slide the heat shield under the stove and position over the tek screws and tighten.

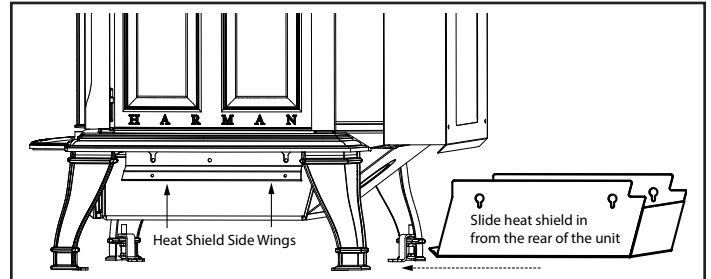

F. Optional Cozy Screen

This appliance has been tested and approved for burning as an open fireplace. To do so, a spark screen (Harman part# 1-00-249173; Cozy Screen) must be installed over the front door opening. The by-pass damper must be kept in the open position.

The Cozy Screen can be used from the start of a fire or can be used with an existing one. When starting a fire with the Cozy Screen, smoke spillage may occur until it develops a draft strong enough to pull all smoke back into the flue.

DO NOT LEAVE THE APPLIANCE UNATTENDED WITH THE DOOR OPEN!

Load only small amounts of wood at a time.

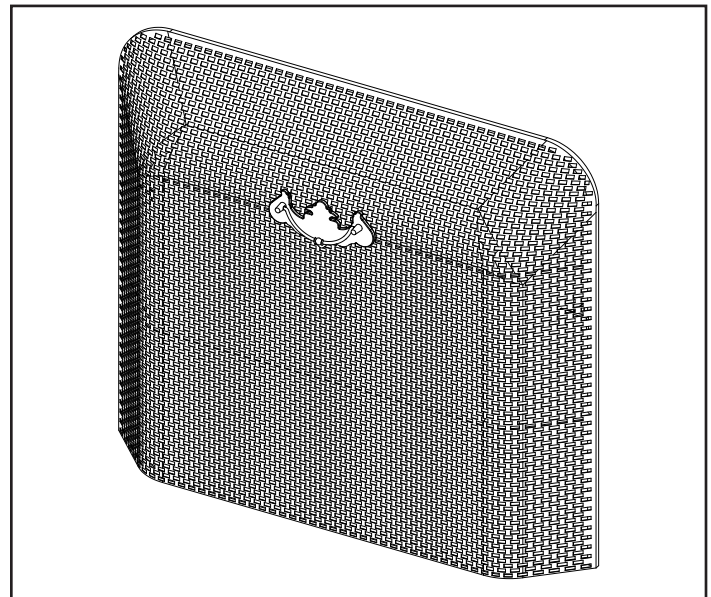

7 Operating Instructions



CAUTION

Approved for use with wood fuel only. The use of any other fuel will void the product warranty and may cause damage to the appliance and/or your home.



WARNING

"NEVER USE GASOLINE, GASOLINE-TYPE LANTERN FUEL, KEROSENE, CHARCOAL LIGHTER FLUID, OR SIMILAR LIQUIDS TO START OR "FRESHEN UP " A FIRE IN THIS HEATER. KEEP ALL SUCH LIQUIDS WELL AWAY FROM THE HEATER WHILE IN USE".

A. Fuel Specifications

Select only **dry, seasoned wood**. Wood for burning should never be exposed to rain or extremely damp conditions. Hardwoods are favored because they are heavier and contain more heating capacity (BTU's) per load than do softwoods. Fuel wood should be split and stored under cover for "seasoning" - at least a year is recommended. Your stove is not an incinerator - do not burn garbage, painted or treated wood, plastic, or other debris.

Keep the area around the stove free from clutter. Keep all combustibles, including fuel, beyond the code-required clearance distance (48" or 1215mm in the U.S., 1525mm or 60" in Canada). Never store fuel in front of the stove where it could interfere with door operation, safe loading, and ash removal.



WARNING

BURNING COLORED PAPER, CARDBOARD, SOLVENTS, TRASH AND GARBAGE OR ALTERING THE STOVE FOR HIGHER HEAT OUTPUT MAY CAUSE DAMAGE TO THE STOVE AND COULD RESULT IN A HOUSE FIRE. USE ONLY APPROVED FUELS AND FOLLOW ONLY THESE OPERATION GUIDELINES.



CAUTION

ALWAYS WEAR FIRE RETARDANT GLOVES WHEN OPERATING THE STOVE.

SAFETY NOTICE

IF THIS APPLIANCE IS NOT PROPERLY INSTALLED, OPERATED AND MAINTAINED, A HOUSE FIRE MAY RESULT. FOR YOUR SAFETY, FOLLOW INSTALLATION DIRECTIONS. CONTACT LOCAL BUILDING OR FIRE OFFICIALS ABOUT RESTRICTIONS AND INSTALLATION INSPECTION REQUIREMENTS IN YOUR AREA.

B. General Operating Information

Draft

Before you install and operate your Oakwood wood stove, please read the entire contents of this manual. Pay particular attention to the explanation of draft and its effect on stove performance in the Installation section. By following the installation and operating guidelines, you will ensure proper draft and gain maximum efficiency and enjoyment from your stove.

Do not alter the position of the andirons. Building a fire too close to the glass may cause damage to the glass, creating a serious risk of fire and property damage.



WARNING

DO NOT BURN GARBAGE OR FLAMMABLE LIQUIDS SUCH AS GASOLINE, NAPHTHA, OR ENGINE OIL.

Doors

Your stove has a large glass-paneled door for loading and fire viewing, a separate smaller door for removing ashes and a top loading door.

Front Door

Before opening, always check for wood, embers, or ash that may be ready to fall out of the door.

To open the glass door, open the bypass damper first, then turn the handle clockwise and pull out; to close the door, push the door closed with the handle in the open position, then turn, counter-clockwise, to engage the latch.

Ash Door

To open the ash door, lift up the handle and pull out. Close the door by pushing in and pushing the handle all the way down.

Top Load Door

To open the top load door, open the bypass damper and then lift to open the top load door.

All doors must be closed while the stove is in normal operation, and the gaskets routinely examined for wear and replaced when necessary. Good door seals are important for maintaining control of the stove. Never operate with the ash door open. Operating the stove with the ash door open, or with a door inadequately sealed, could create a serious overfiring condition (discussed later in this section).

The glass used in your Oakwood is manufactured to exact standards to withstand the high heat of the fire, but like all glass, it must be treated with common sense and care. Never abuse the glass by slamming the door shut or striking the glass with a heavy object. If the glass is broken or damaged, do not operate the stove until it has been replaced

(See instructions in the Maintenance section.)

Grates

The Harman Oakwood's unique grate system consists of one flat bottom grate, and two front andirons. The bottom grate has slots which allow the ash to fall into the ash pan by passing a poker back and forth across the grate. The andirons keep the fuel from coming into direct contact with the glass, and keep hot coals and embers from spilling out while reloading. Never build a fire directly against the glass.

The grates and andirons must remain in place at all times. Do not tamper with or change the configuration of this grate system.

C. The Combustion Process

Combustion in the Harman Oakwood is precisely controlled and is best explained in two parts.

During a wood fire, combustion air enters at the bottom front of the stove where it travels upward through channels at either side of the front door. From the manifold located above the front door, it is directed into the firebox as a sheet of air flowing between the glass and the wood. This concept helps to keep the glass clean, while providing the oxygen needed to sustain burning. This is what is known as "Primary Combustion".

Additional air enters at the bottom rear of the stove body. Some of this air enters through holes in the rear bricks where it is used to revitalize the fire at the rear of the firebox. The remainder is delivered into the "Firedome" combustion package where the "Secondary Combustion", or re-burning of the smoke, occurs.

During combustion, the burning of wood proceeds through several stages. The initial or evaporation stage is where the moisture in the wood is driven off in the form of steam. A second stage is where the volatile gases contained in the wood are released and burned. This represents most of the wood's heating capacity. The final stage is the charcoal stage where the charcoal burns the remaining heat content in the wood fuel. Ash remains after the burning is complete. Within the primary firebox two or more of these stages of combustion are occurring at once.

Always be sure to provide adequate ventilation to the room where the appliance is located, to prevent air starvation. In tight construction, consider installing outside air to the appliance.

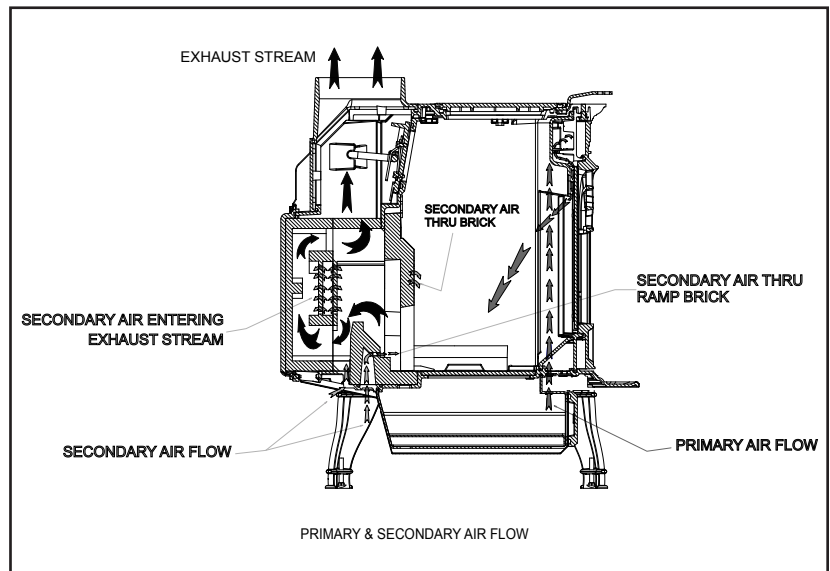

D. User Controls

Two important controls - the damper bypass handle and the air control lever regulate the operation and output of the stove.

To open the top or front loading door, you must open the damper bypass, or smoke will come in the room. In this mode of operation the combustion gases go directly from the main combustion chamber to the flue collar and exit into the chimney.

NOTE: The bypass damper must be open for smokeless loading. Open the bypass damper by turning the handle clockwise while facing handle.

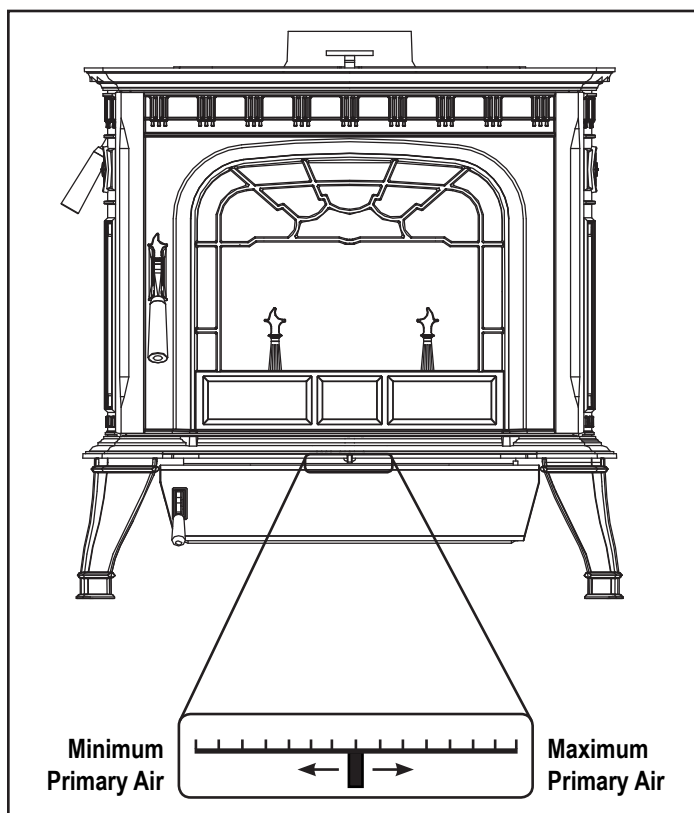
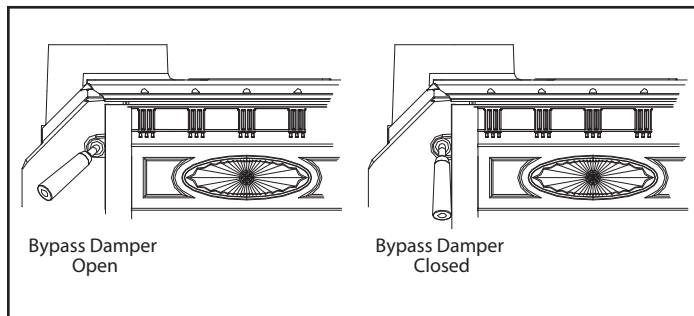

The air control lever is located directly below the load door. Sliding this lever allows you to vary the amount of air to the fire, creating a range of heat outputs. The lowest heat output setting is to the left, and the highest is to the right. The notches are provided as a reference for your comfortable heat settings. Do not, under any circumstances, alter the configuration or operation of the air control lever.

For low burn, slide the air control to the left. For medium burns, use notches 1 to 2. Maximum heat is attained with the air control all the way to the right. Do not burn the stove continuously at the maximum setting. If maximum heat is required day after day, the stove is too small for the area you are trying to heat.

If your wood is not seasoned long enough or is high in moisture content, you may need to adjust the primary air slightly higher to sustain a low burn rate with the cleanest possible exhaust.

E. Before Your First Fire

- Be sure the appliance is installed properly and that all safety requirements have been met. Pay particular attention to the clearances to combustibles, floor protection and the venting instructions.
- Test your smoke detector(s) and CO detector(s) to the specifications of the manufacturer.
- Double check that the ash pan and internal firebox are empty.
- Be sure to read this entire manual.

DO NOT OVERLOAD THE APPLIANCE. DOORS MUST BE CLOSED WHEN IN OPERATION

F. Building and Maintaining a Fire

Begin with the bypass damper open, and the air control lever at the maximum setting, all the way to the right. Be sure the ash pan door is closed and latched.

Start with a bed of crumpled paper and kindling sized about finger width; place several 1" - 2" (25 - 50mm) split pieces of dry wood on top of the kindling, followed by a few 2" - 3" (50 - 80mm) split pieces. Lay the wood in a crossed pattern to allow maximum air flow. Ignite the paper and close the loading door(s). Allow this start-up fire to burn for a few minutes, keeping the bypass damper open. Add about five more pieces of wood in the 2 to 3 inch (50 - 80mm) size range, making sure that the fuel bed is all the way across the firebox and staggered to allow airflow. Close the door and allow this loading to burn a few minutes.

Add increasingly larger pieces of wood to the fire until you have a thick bed of hot embers, approximately 2 to 3 inches deep at the back of the grate and at least an inch deep at the front. **You must have this charcoal bed established before you close the bypass damper.**

Providing you have the charcoal bed described, close the bypass damper by pulling the handle toward the front of the stove.

This will begin the highly efficient mode of operation where the exhaust gases get re-burned in the secondary combustion package. If you cannot achieve a charcoal bed within the first 15 to 20 minutes, your wood is likely too wet, and you may need to burn the fire longer and/or hotter to compensate for the extra energy needed to drive out the moisture. If, after five minutes of burning with the damper closed, smoke is visible coming from the chimney, you probably do not have the proper coal bed. Open the bypass damper and continue with the process until a significant coal bed is formed.

Install a magnetic probe stack thermometer 24" above the flue collar of the unit. With the thermometer at this location, the following guidelines can be helpful if followed; however, remember these are only rough guidelines and a myriad of other factors contribute to the operation of the Harman® Oakwood wood stove. While establishing a coal bed, prior to engaging the Firedome, a 2-3" coal bed and a stack temperature of 900°F - 1100°F indicate that the stove is normally ready for Firedome mode. With the Firedome engaged, temperatures of 500°F – 800°F indicate the unit is burning properly and no adjustment is necessary. Temperatures below 400°F with wood remaining in the firebox indicate the Firedome system is not working and the stove is likely smoking. Open the damper, and allow the unit to burn with the damper open for 10-15 minutes to reheat before attempting to reengage the Firedome system. Lastly, temperatures above 1000°F with the Firedome engaged indicate the unit is being over-fired. Unit damage may occur from operating the unit at stack temperatures above 1000°F.

If, after five minutes of burning with the damper closed, smoke is visible coming from the chimney, you probably do not have the proper coal bed. Open the bypass damper and continue with the process until a significant coal bed is formed.

Always remember to open the bypass damper when you are loading, this allows the exhaust gases to pass directly into the flue outlet and reduces the chance of smoke spillage into the room.

Reloading: Once you have prepared and maintained a thick charcoal bed, and the secondary combustion is established, you should be able to reload the stove at any time by simply opening the bypass damper, then the load door, adding fuel and closing the door then the damper. This depends on coal bed size, load size and moisture content of fuel.

Removing Ashes: Before reloading, empty the ash pan (remember to close the ash door while emptying the pan). The ashes should be the coolest at this time. Remove ashes from the fire chamber periodically by raking a poker across the bottom grates.

Excessive ash buildup can prevent proper venting of exhaust gases. Do not allow the ash pan to over-fill. Ash buildup between the ash pan and the bottom of the grate can cause the grate to overheat and wear out prematurely.

The Oakwood is designed to provide access to the ash pan without the need for opening the main door. Before opening the ash door and removing the ash pan, open the bypass damper. Wearing heavy protective gloves, open the ash door and remove the ash pan by pulling it forward by the handle. Close the ash door and damper bypass before taking the ashes outside for safe disposal.

Ashes should be placed in a metal container with a tight fitting lid. The closed container of ashes should be placed on a noncombustible floor or on the ground, well away from all combustible materials, pending final disposal. If the ashes are disposed of by burial in soil or otherwise locally dispersed, they should be retained in the closed container until all cinders have thoroughly cooled.

Never use the ash disposal container for other trash. Wood ash can be added to your garden or compost.

 CAUTION
THE STOVE IS HOT WHILE IN OPERATION. KEEP CHILDREN, CLOTHING AND FURNITURE AWAY. CONTACT MAY CAUSE SKIN BURNS.
NEVER LEAVE THE STOVE UNATTENDED IF EITHER THE ASH OR LOAD DOOR IS OPEN. OVERFIRING MAY RESULT.
RISK OF EXCESSIVE TEMPERATURES. KEEP ASH DOOR CLOSED DURING FIRING OF THE HEATER.

Avoid overfiring your stove. Overfiring is a potentially hazardous situation which can lead to overheating of combustible materials nearby, damage to the stove, and in extreme cases, cause a fire. Overfiring is caused by: 1. Too much air flowing through the stove too quickly. 2. You may have positioned the primary air control lever too far to the right. 3. Inadvertently leaving the damper open or 4. Not keeping up with routine maintenance, such as checking door gaskets for wear.

Overfiring results in excessive fuel consumption, and may cause parts of the stove or chimney connector to glow red. If you notice signs of overfiring, reduce the air supply to the fire, and review the Maintenance section in this manual.

In the event of a chimney fire, call your local fire department; make sure everyone is safely out of the house. Reduce the air intake of the stove as much as possible using the air control lever; close the bypass damper to further restrict air flow. Do not throw water on the fire; this can cause stove damage and create an even more dangerous situation. Have your chimney professionally cleaned and inspected before resuming burning in your stove.

As you begin to operate your stove at higher temperatures, you will notice a "hot" or unpleasant smell; this is just the paint going through the curing process, and will disappear after a few fires.

8 Service & Maintenance

Solid fuel burning space heaters must be cleaned regularly, as soot, ash and creosote may accumulate.

When properly maintained, your wood stove will give you many years of trouble-free service. **Contact your dealer** to answer questions regarding proper operation, trouble-shooting and service for your appliance. Visit www.harmanstoves.com to find a dealer. We recommend annual service by a qualified service technician.

A. Creosote - Formation and Need For Removal;

When wood is burned slowly, it produces tar and other organic vapors which combine with expelled moisture to form creosote. The creosote vapors condense in the relatively cool chimney flue of a slow burning fire. As a result, creosote residue accumulates on the flue lining. When ignited, this creosote makes an extremely hot fire. The chimney and chimney connector should be inspected at least once every two months during the heating season to determine if a creosote buildup has occurred. If creosote has accumulated, it should be removed to reduce the risk of a chimney fire.

If you experience a chimney fire; Close the air control and bypass damper and notify the fire department. Do NOT apply water to the fire, in the firebox or in the chimney. Do not operate the appliance until the chimney and connector have been inspected and approved by a chimney professional.

Do not burn any fuel other than wood, such as charcoal, which can cause increased carbon monoxide production or overfiring. Never use highly volatile substances in your stove, such as gasoline, which could cause an explosion.

When solid fuels are burned completely, they produce water and carbon dioxide. However, in long slow burns, a substantial amount of carbon monoxide may be produced. If allowed to build up, carbon monoxide (which is odorless) can prove fatally poisonous. Proper ventilation and draft will prevent this from happening. If you smell smoke, turn up the air control lever setting, and thoroughly ventilate your dwelling. During future burns, be careful not to overload the stove with fuel, so you will not be tempted to constantly operate at a low air control setting.

Other causes of poor ventilation or draft are icing, exhaust fans, a blocked outside air inlet, and room air starvation. If your stove is sluggish and you get occasional odor, check these possibilities and increase the air flow in your home.

Seasonal cleaning

At least once per year, the stove, venting connectors and chimney should be thoroughly cleaned. If the areas are found to have an excessive build up of ash or creosote, it is recommended to increase the frequency of the cleaning. This will extend the life of the appliance and its components. A vacuum specifically designed for ash is preferred, however a standard shop-style vacuum with a HEPA filter may also work just fine.

During cleaning, caution must be taken not to damage the white / gray colored ceramic combustion package in the rear of the firebox. When using a brush in the chimney or venting connector, the by-pass damper should be placed in the open position to help prevent ash, creosote or other debris from falling down onto and around the combustion package. This also protects the top of the combustion package from tool or brush damage and diverts most of the removed materials into the firebox for easy clean-up and removal. Once the venting system has been cleaned, remove the first section of connector pipe from the appliance flue collar. Carefully vacuum the ash and debris from around the sides and top of the combustion package.

The shoe brick must be removed to allow vacuum access for cleaning the front portion of the combustion package.

Always use caution when refueling or when vacuuming the firebox and combustion package. Some users have damaged their combustion package with vacuum cleaner tools, and fire pokers.



CAUTION

ALWAYS WEAR FIRE-RESISTANT GLOVES TO OPERATE THE STOVE. THE AIR CONTROL IS HOT WHILE IN OPERATION.

IMPORTANT NOTE

The only suitable method for removing creosote from the venting system is a chimney brush. Creosote sweeping logs, powders and other products have the potential to damage the Firedome combustion system, and are not recommended for use in Harman wood stoves. Use of chemical creosote removal products will void the warranty of the Firedome combustion system.

B. General Maintenance Procedures

Ash Removal

- **Frequency:** As needed / Every day or two
- **By:** User

Wear Leather Gloves To Prevent Skin Burns!

Open the ash removal door by lifting upward on the latch handle, then swing the door open. Pull the ash pan out of the firebox, using the lip on the front of the pan. Once the ash pan is removed from the stove, you can flip the carry handle up for convenience.

If removing ashes while a fire is burning, close and latch the ash door while disposing of the ashes.

DO NOT leave the appliance unattended with the ash door open.

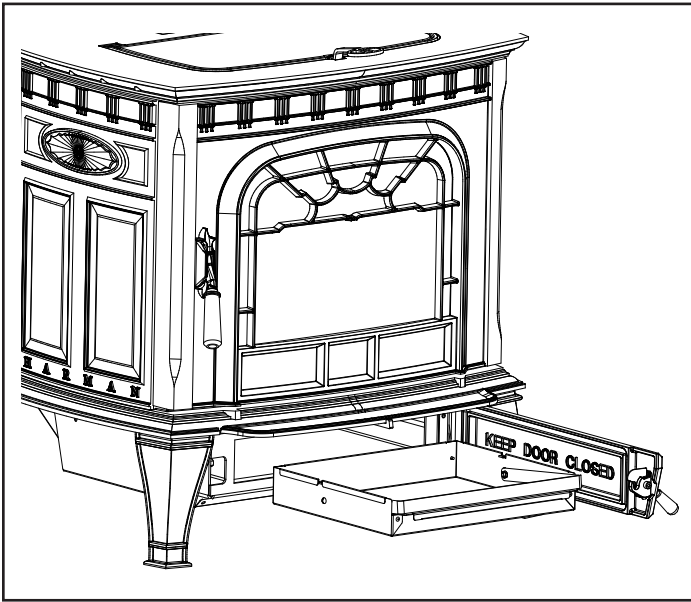

Ashes must be placed in a metal container with a tight fitting lid. The closed container of ashes should be placed on a non-combustible floor or on the ground, well away from all combustible materials, pending final disposal. If the ashes are disposed of by burial in soil or otherwise locally dispersed, they should be retained in the closed container until all cinders have thoroughly cooled. Do not use the ash container for other debris or yard waste.

Door Glass

- **Frequency:** As needed / Weekly
- **By:** User

Whenever the view of the fire is obstructed, or weekly, clean the glass using a soft cloth dampened with standard household glass cleaner.

Never spray glass cleaner directly onto hot glass. Apply the cleaner to the cloth then wipe the glass.

Fly-ash allowed to accumulate on the glass may lead to permanent fogging or "crazing" of the glass.

Inspect the glass and sealing gasket. Replace gasket as needed. Do not operate the stove with a broken glass. Replacement glass, which is ceramic glass, should be obtained only through your Harman dealer.

To replace a broken glass; first be sure to carefully remove the broken glass and any remaining shards or pieces. With the door laying on a flat surface, lay the gasketed glass panel onto the door and be sure it is properly fitted into the channel. Lay the glass retainer clips in place near each corner, and secure them using the 3/8" screws. Be sure to tighten each screw equally so you don't create a pressure point on the glass.



CAUTION

NEVER USE ABRASIVE MATERIALS ON THE GLASS.

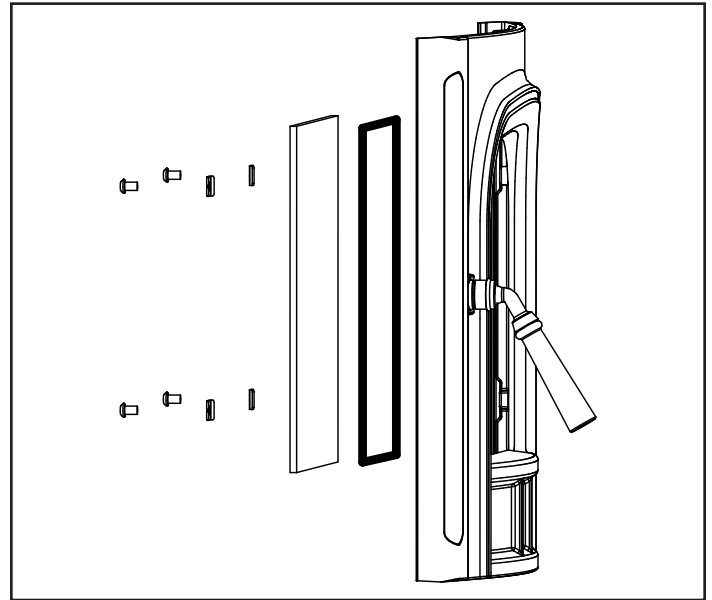

WARNING

DO NOT ABUSE GLASS BY STRIKING OR SLAMMING THE DOOR CLOSED. THIS TYPE OF BREAKAGE IS NOT COVERED BY THE PRODUCT WARRANTY.

Firebox

- **Frequency:** As necessary / Yearly
- **By:** User

Cleaning the firebox and internal heat exchange surfaces is recommended to maintain thermal efficiency. Depending on the quality and quantity of fuel being used, you may want to perform this cleaning monthly.

Be sure to clean these areas thoroughly at the end of the heating season.

Brush and vacuum all internal surfaces at the end of the heating season. Ashes will draw moisture and may promote rust formation.

Chimney / Chimney Connector

- **Frequency:** As necessary / Yearly
- **By:** Qualified Service Technician / Chimney Sweep

Disassemble the chimney connector and take it outdoors for inspection and cleaning. Replace weak sections of connector.

Inspect chimney for signs of deterioration. Repairs to a masonry chimney should be made by a professional mason. Replace damaged sections of prefabricated chimney. Your local dealer or chimney sweep can help determine when replacement is necessary.

Thoroughly clean the chimney.

Note: When cleaning the chimney connector above the appliance, keep the bypass damper in the open position. This will keep any loosened material from falling into the Firedome Plus combustion chamber.

FireDome Technology

- **Frequency:** Yearly
- **By:** Qualified Service Technician / Chimney Sweep

Inspect and clean ash accumulation from around the Firedome Combustion System being careful not to damage the Firedome.

- Remove chimney connector from unit and pull unit away from the wall.

- Carefully vacuum the ash and debris from around the sides and top of the Firedome combustion package.

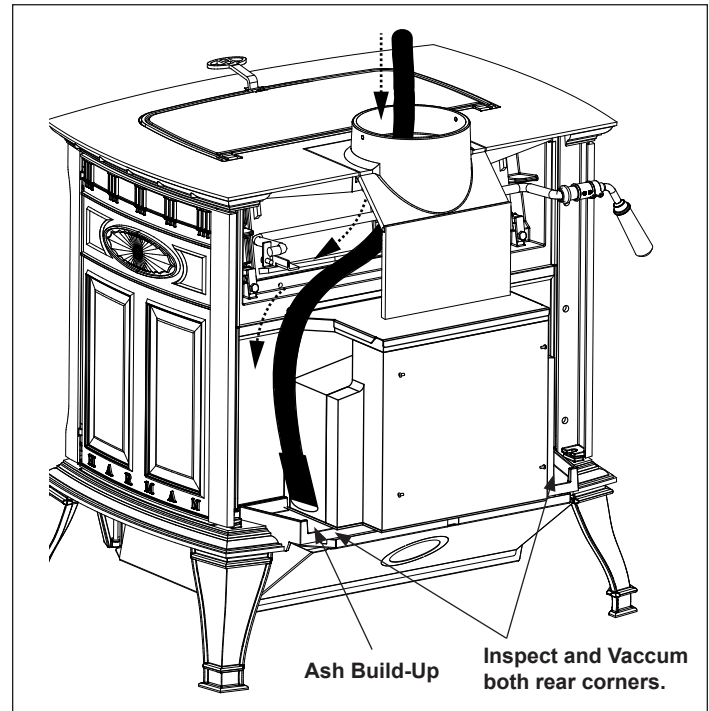

9 Reference Materials

B. Warranty Policy

Hearth & Home Technologies LIMITED LIFETIME WARRANTY

Hearth & Home Technologies, on behalf of its hearth brands ("HHT"), extends the following warranty for HHT gas, wood, pellet, coal and electric hearth appliances that are purchased from an HHT authorized dealer.

WARRANTY COVERAGE:

HHT warrants to the original owner of the HHT appliance at the site of installation, and to any transferee taking ownership of the appliance at the site of installation within two years following the date of original purchase, that the HHT appliance will be free from defects in materials and workmanship at the time of manufacture. After installation, if covered components manufactured by HHT are found to be defective in materials or workmanship during the applicable warranty period, HHT will, at its option, repair or replace the covered components. HHT, at its own discretion, may fully discharge all of its obligations under such warranties by replacing the product itself or refunding the verified purchase price of the product itself. The maximum amount recoverable under this warranty is limited to the purchase price of the product. This warranty is subject to conditions, exclusions and limitations as described below.

WARRANTY PERIOD:

Warranty coverage begins on the date of original purchase. In the case of new home construction, warranty coverage begins on the date of first occupancy of the dwelling or six months after the sale of the product by an independent, authorized HHT dealer/ distributor, whichever occurs earlier. The warranty shall commence no later than 24 months following the date of product shipment from HHT, regardless of the installation or occupancy date. The warranty period for parts and labor for covered components is produced in the following table.

The term "Limited Lifetime" in the table below is defined as: 20 years from the beginning date of warranty coverage for gas appliances, and 10 years from the beginning date of warranty coverage for wood, pellet, and coal appliances. These time periods reflect the minimum expected useful lives of the designated components under normal operating conditions.

Warranty Period		HHT Manufactured Appliances and Venting							Components Covered
Parts	Labor	Gas	Wood	Pellet	EPA Wood	Coal	Electric	Venting	
1 Year		X	X	X	X	X	X	X	All parts and material except as covered by Conditions, Exclusions, and Limitations listed
2 years				X	X	X			Igniters, electronic components, and glass
		X	X	X	X	X			Factory-installed blowers
				X					Molded refractory panels
3 years				X					Firepots and burnpots
5 years	1 year			X	X				Castings and baffles
7 years	3 years		X	X	X				Manifold tubes, HHT chimney and termination
10 years	1 year	X							Burners, logs and refractory
Limited Lifetime	3 years	X	X	X	X	X			Firebox and heat exchanger
90 Days		X	X	X	X	X	X	X	All replacement parts beyond warranty period

See conditions, exclusions, and limitations on next page.

WARRANTY CONDITIONS:

- This warranty only covers HHT appliances that are purchased through an HHT authorized dealer or distributor. A list of HHT authorized dealers is available on the HHT branded websites.
- This warranty is only valid while the HHT appliance remains at the site of original installation.
- This warranty is only valid in the country in which the HHT authorized dealer or distributor that sold the appliance resides.
- Contact your installing dealer for warranty service. If the installing dealer is unable to provide necessary parts, contact the nearest HHT authorized dealer or supplier. Additional service fees may apply if you are seeking warranty service from a dealer other than the dealer from whom you originally purchased the product.
- Check with your dealer in advance for any costs to you when arranging a warranty call. Travel and shipping charges for parts are not covered by this warranty.

WARRANTY EXCLUSIONS:

This warranty does not cover the following:

- Changes in surface finishes as a result of normal use. As a heating appliance, some changes in color of interior and exterior surface finishes may occur. This is not a flaw and is not covered under warranty.
- Damage to printed, plated, or enameled surfaces caused by fingerprints, accidents, misuse, scratches, melted items, or other external sources and residues left on the plated surfaces from the use of abrasive cleaners or polishes.
- Repair or replacement of parts that are subject to normal wear and tear during the warranty period. These parts include: paint, wood, pellet and coal gaskets, firebricks, grates, flame guides, batteries and the discoloration of glass.
- Minor expansion, contraction, or movement of certain parts causing noise. These conditions are normal and complaints related to this noise are not covered by this warranty.
- Damages resulting from: (1) failure to install, operate, or maintain the appliance in accordance with the installation instructions, operating instructions, and listing agent identification label furnished with the appliance; (2) failure to install the appliance in accordance with local building codes; (3) shipping or improper handling; (4) improper operation, abuse, misuse, continued operation with damaged, corroded or failed components, accident, or improperly/incorrectly performed repairs; (5) environmental conditions, inadequate ventilation, negative pressure, or drafting caused by tightly sealed constructions, insufficient make-up air supply, or handling devices such as exhaust fans or forced air furnaces or other such causes; (6) use of fuels other than those specified in the operating instructions; (7) installation or use of components not supplied with the appliance or any other components not expressly authorized and approved by HHT; (8) modification of the appliance not expressly authorized and approved by HHT in writing; and/or (9) interruptions or fluctuations of electrical power supply to the appliance.
- Non-HHT venting components, hearth components or other accessories used in conjunction with the appliance.
- Any part of a pre-existing fireplace system in which an insert or a decorative gas appliance is installed.
- HHT's obligation under this warranty does not extend to the appliance's capability to heat the desired space. Information is provided to assist the consumer and the dealer in selecting the proper appliance for the application. Consideration must be given to appliance location and configuration, environmental conditions, insulation and air tightness of the structure.

This warranty is void if:

- The appliance has been over-fired or operated in atmospheres contaminated by chlorine, fluorine, or other damaging chemicals. Over-firing can be identified by, but not limited to, warped plates or tubes, rust colored cast iron, bubbling, cracking and discoloration of steel or enamel finishes.
- The appliance is subjected to prolonged periods of dampness or condensation.
- There is any damage to the appliance or other components due to water or weather damage which is the result of, but not limited to, improper chimney or venting installation.

LIMITATIONS OF LIABILITY:

- The owner's exclusive remedy and HHT's sole obligation under this warranty, under any other warranty, express or implied, or in contract, tort or otherwise, shall be limited to replacement, repair, or refund, as specified above. In no event will HHT be liable for any incidental or consequential damages caused by defects in the appliance. Some states do not allow exclusions or limitation of incidental or consequential damages, so these limitations may not apply to you. This warranty gives you specific rights; you may also have other rights, which vary from state to state. EXCEPT TO THE EXTENT PROVIDED BY LAW, HHT MAKES NO EXPRESS WARRANTIES OTHER THAN THE WARRANTY SPECIFIED HEREIN. THE DURATION OF ANY IMPLIED WARRANTY IS LIMITED TO DURATION OF THE EXPRESSED WARRANTY SPECIFIED ABOVE.

