

Installation & Operating Manual

NOTICE: SAVE THESE INSTRUCTIONS



Model(s):

Magnafire Elite Coal Fireplace Insert



WARNING

HOT SURFACES!



Glass and other surfaces are hot during operation and cool down.

Hot glass will cause burns.

- Do not touch glass until it is cooled
- NEVER allow children to touch glass
- Keep children away
- CAREFULLY SUPERVISE children in same room as stove.
- Alert children and adults to hazards of high temperatures.

High temperatures may ignite clothing or other flammable materials.

- Keep clothing, furniture, draperies and other flammable materials away.

This unit has been retired.
Service parts pages within have
been removed.
For replacement parts, please
refer to the individual service parts
list located on the brand websites

SAFETY NOTICE

PLEASE READ THIS ENTIRE MANUAL BEFORE YOU INSTALL AND USE YOUR NEW ROOM HEATER. FAILURE TO FOLLOW INSTRUCTIONS MAY RESULT IN PROPERTY DAMAGE, BODILY INJURY, OR EVEN DEATH.

LISTED FOR USE IN THE U.S. ONLY. NOT SUITABLE FOR INSTALLATION IN MOBILE HOMES

IF THIS FIREPLACE INSERT IS NOT PROPERLY INSTALLED, A HOUSE FIRE MAY RESULT. FOR YOUR SAFETY, FOLLOW INSTALLATION DIRECTIONS.

CONTACT LOCAL BUILDING OR FIRE OFFICIALS ABOUT RESTRICTIONS AND INSTALLATION INSPECTION REQUIREMENTS IN YOUR AREA.

CONTACT YOUR LOCAL AUTHORITY (SUCH AS MUNICIPAL BUILDING DEPARTMENT, FIRE DEPARTMENT, FIRE PREVENTION BUREAU, ETC.) TO DETERMINE THE NEED FOR A PERMIT.

CETTE GUIDE D'UTILISATION EST DISPONIBLE EN FRANCAIS. CHEZ VOTRE CONCESSIONNAIRE DE HARMAN® HOME HEATING.

SAVE THESE INSTRUCTIONS.

Table Of Contents

Safety Considerations	4
Assembly & Installation	5
Venting & Chimneys	8
Wiring Diagram	10
Grate System	11
Warnings & Special Instructions	11
Operation & Maintenance	12
Warranty	15
Service & Maintenance Log	17

→ = Contains updated information

Manufactured By:

HARMAN®

BUILT TO A STANDARD, NOT A PRICE

a Division of Hearth and Home Technologies
352 Mountain House Road
Halifax, PA 17032
www.harmanstoves.com

SAFETY

1.1 KEEP CHILDREN AWAY -- MAY CAUSE SERIOUS BURNS

CAUTION: ALL SURFACES OF STOVE ARE HOT, DO NOT TOUCH. KEEP CHILDREN AWAY. SERIOUS BURNS WILL RESULT IF TOUCHED. THIS IS A HEAT PRODUCING APPLIANCE. SERIOUS BURNS MAY RESULT IF THE STOVE IS TOUCHED DURING FIRING.

CAUTION: Maintain at least a 36" clearance from insert to all combustibles materials. Clearance to a mantel is 18" from the insert, If mantel is less the 18", install a metal shield between insert and mantel.

If the hearth is built on a combustible floor, a protective material must be installed under the insert. This material must be a minimum 3/8" of .84k per inch.

1.2 FUEL/FIRING WARNINGS

DANGER! FIRE HAZARD! DO NOT USE CHEMICALS OR FLUIDS TO START OR "FRESHEN UP" A FIRE. SEVERE BODY BURNS OR A FIRE IN YOUR HOME COULD RESULT. DO NOT BURN GARBAGE, GASOLINE, THINNERS, DRAIN OR ENGINE OIL, KEROSENE, OR FUEL OIL, ETC. AN EXPLOSION, A HOUSE FIRE, OR PERSONAL INJURY COULD RESULT. KEEP ALL SUCH LIQUIDS WELL AWAY FROM THE STOVE.

This heater is for burning coal only. Use of any other fuel except for coal ignition is a violation of Federal Law.

When and if the insert reaches **500 degrees Fahrenheit (maximum temperature)**, the insert is being overfired. We recommend the purchase of a Magnetic Temperature Gauge to monitor the Insert temperatures relative to the amount of draft at which the customer permits the stove to operate.

It has been verified that creosote will ignite at 650 degrees Fahrenheit. It is the owner's responsibility to follow these recommendations.

This insert consumes air when it is burning. It is advisable that a window in the vicinity be opened slightly while stove is burning if your house is tightly sealed and insulated. (Information contained in this manual is manufacturer's recommendations and if there is any difference between our recommendations and local code requirements, we suggest following local code requirements.

1.3 CURING PAINT

During the first few hours of burning, a blue smoke will be observed rising from the painted surface of the stove. It is advisable to increase the amount of fresh air in the room during this breaking-in period. This may be achieved by opening the doors, windows, etc. Don't be alarmed, this is normal.

1.4 MOBILE HOMES

This unit is not approved for installation in mobile homes.

NOTE: Many municipalities have special codes relating to fireplace inserts, it is strongly suggested that you check with local Fire and Code officials before installing an insert.

IT IS YOUR RESPONSIBILITY TO MAKE SURE THAT YOUR INSTALLATION MEETS ALL LOCAL AND STATE REGULATIONS.

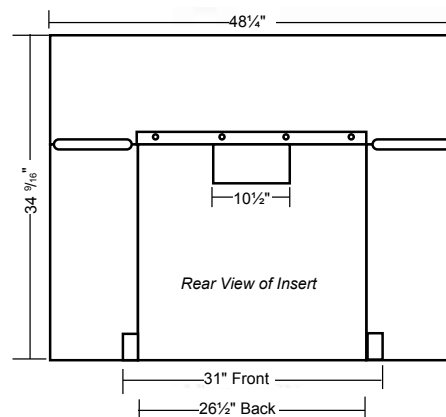
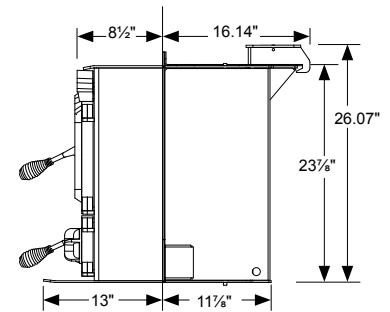
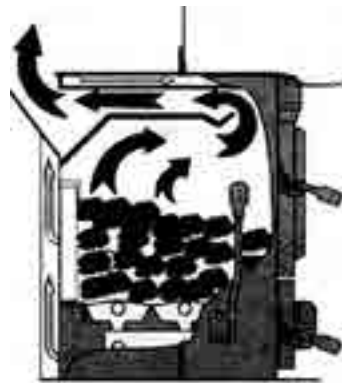

ASSEMBLY & INSTALLATION

2.1 PARTS INSPECTION

Upon receipt of your Harman® Insert, please be sure you have all of the pieces. You should find the following:

1. Ash Pan
2. Shaker Handle
3. Manual and Warranty
4. Steel Flue Plate (see illustration in section 2.2)
5. Door Kit - Separate carton
 - a. Glass Frame
 - b. Glass, Door Top Trim, Draft Control, (3) Spring handles, And Hardware Pack.
6. Wing Kit - 2 separate cartons
 - a. Top Wing and Brass Trim
 - b. Side Wings with Blowers, Power Cord, and a package containing the blower box covers and hardware.

2.2 INSTALLATION INSTRUCTIONS

The minimum fireplace size that your Harman® Insert will fit into is 24" high by 31" wide. A critical dimension for fit in the fireplace is that you must have 16 1/8" depth minimum at 24" height minimum.

The first step in installing your new insert is to locate the damper in the top of the fireplace. At a minimum, the damper must be secured in the open position with wire or other non-combustible material. If possible, it is best to totally remove the damper to prevent accidental closing.

Before proceeding with installation, it is recommended that you have your chimney cleaned and inspected by a professional to determine that your chimney is in safe condition.

IT IS YOUR RESPONSIBILITY TO MAKE CERTAIN YOUR CHIMNEY IS IN THE PROPER CONDITION TO SAFELY FUNCTION WITH A SOLID FUEL BURNING APPLIANCE. IT IS ALSO YOUR RESPONSIBILITY TO COMPLY WITH ALL STATE AND LOCAL CODES PERTAINING TO INSTALLATION AND BURNING OF SOLID FUELS.

There are two acceptable means for connecting the exhaust of the insert to the chimney.

1. **Direct connect method;** This method employs a short section of stainless steel flex pipe which attaches to the insert and runs through the damper and into the chimney base. This must be run at least as high as the first flue tile. The chimney must be sealed around the flex pipe. this is usually best accomplished with a steel plate or non-combustible packing material around the original damper location.

2. **Positive connect method;** Similarly, this method employs the use of a stainless steel liner, however the liner is run the entire length of the chimney. It is not necessary to seal around the venting at the damper, however the proper flashing must be used at the top of the chimney to ensure that rain and other elements do not enter the chimney.

An oval to round transition such as Simpson Dura-Vent® Item #6DLO-36FR works well for passing through the narrow damper area. In some cases, this piece which is 36 inches long will reach the first flue tile. If more connector is needed, or for a full liner installation, it provides the anchor point for 6inch dura-liner® to be used.

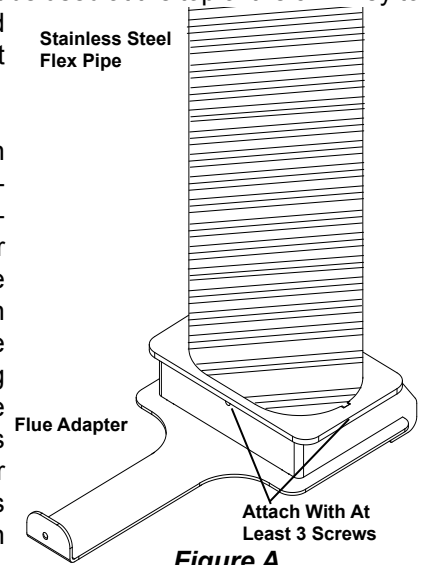

Figure A

See more on chimney requirements later in this manual.

With the liner or connector inserted into the chimney, install the flue adapter to the pipe using a minimum of three screws. Position the adapter at a height of just under 24 inches from the floor of the fireplace. (See Fig. B).

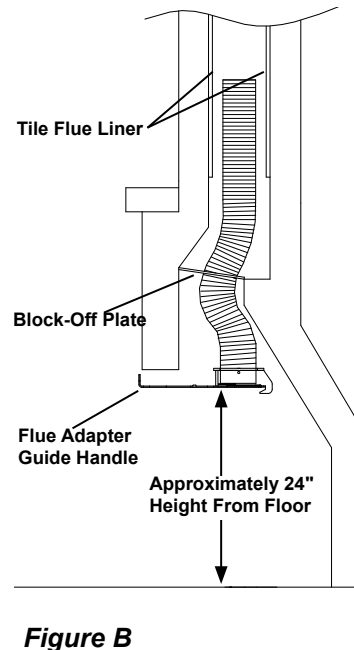

Figure B

ASSEMBLY & INSTALLATION

Next, slide the insert into the fireplace making sure that the front tab of the flue adapter is resting on top of the insert. This tab may now be used as a guide to help locate the connector base on the flue opening of the insert. Begin sliding the insert in place while guiding the connector base into its proper location. With the adapter close to centered on the top of the insert body, the hooks at the back side of the adapter should pull the adapter into position as the insert slides back.

If needed, you can reach up through the hole in the baffle to guide the flue adapter into place.

Open the loading door and look into the rear of the firebox. Notice the hole left in the baffle of the insert. This hole is to allow you to reach into the flue and grab the cross-member in the flue adapter.

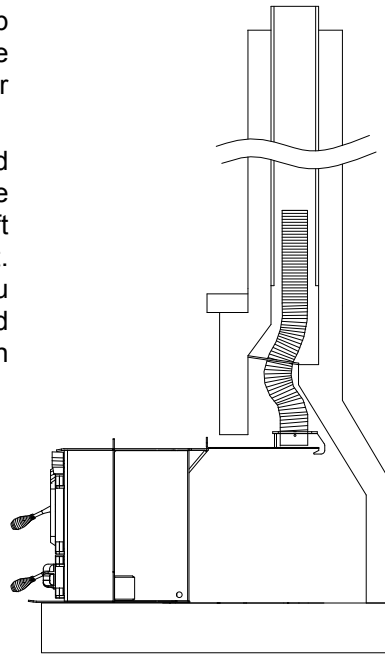
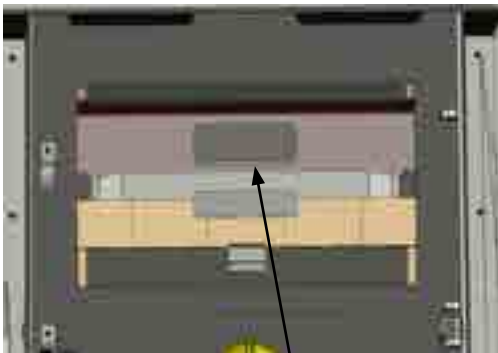

Figure C



Looking through front door

Once the flue adapter is in place on the insert, install one button head screw through the wing mounting flange and into the hole on the flue adapter guide handle. Tighten the screw to secure the flue adapter during the completion of the installation.

After final adjustment, place the flue plate behind the baffle and cover the access hole.

With the insert sitting on the hearth, installation of the insert wings is accomplished by first removing the screws that are around the perimeter of the insert front. Once these screws are removed, the side wing sections should be installed.

Align the holes in the wings with the holes in the insert and begin inserting the screws. Note that there is a right wing and a left wing.

After the side wings are installed, the top wing can be installed. The tabs on the top wing slide behind the bottom wing and the tabs on the bottom wing slide behind the tabs on the top wing.

One step remains before you are ready to slide the insert into its final position in the fireplace. The area between the wing and the fireplace front must be packed with fiberglass insulation to provide a good air seal at the face of the fireplace. This step is very important because a poor seal at this point will cause a loss of draft and could cause poor performance of the insert.

With the insulation in place, go ahead and slide the insert tightly back into the fireplace.

The floor of the insert has adjusting bolts. The adjusting bolts can be reached through the ash door. The bolts can be used to adjust the level of the stove by turning clockwise to raise the corner of the stove, and counter-clockwise to lower the corner of the stove.

The blowers are already installed in the side wings, but you'll need to complete the wiring. First, determine which side the power cord needs to be routed from. Follow the wiring diagram to attach the power cord. Then, link the two blowers together with the high temperature wire that is looped through the back of the insert body.

Place the blower cover retainer in the blower box as shown below. Keep the retainer centered to allow for easier hole location.

Next, using the corner clips provided in the hardware package, install the brass trim onto the lid. Place the lid onto the blower box and slip the flat-head screw downward through the lid and tighten it into the retainer. (Repeat for both sides)

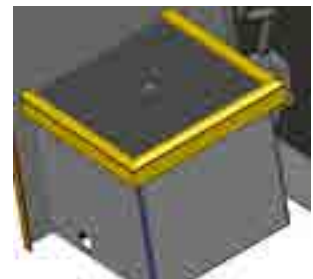

ASSEMBLY & INSTALLATION

Next, install the draft control onto the ash door. Thread the bolt through the knob and install one of the nuts. Slip the remaining end of the bolt through the door and install the second nut. Adjust the nut locations so that the draft control stops open at about 3/8" from the door surface, while still being able to close against the door.

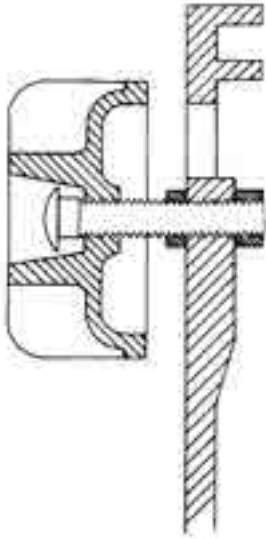

The last step in assembly is the shaker handle. The shaker handle is mounted on the lower left front of the insert with the two hex-head bolts and lock-washers already in the shaker handle mount. If you removed the grates for installation, make sure they are installed properly. Refer to the illustration below.

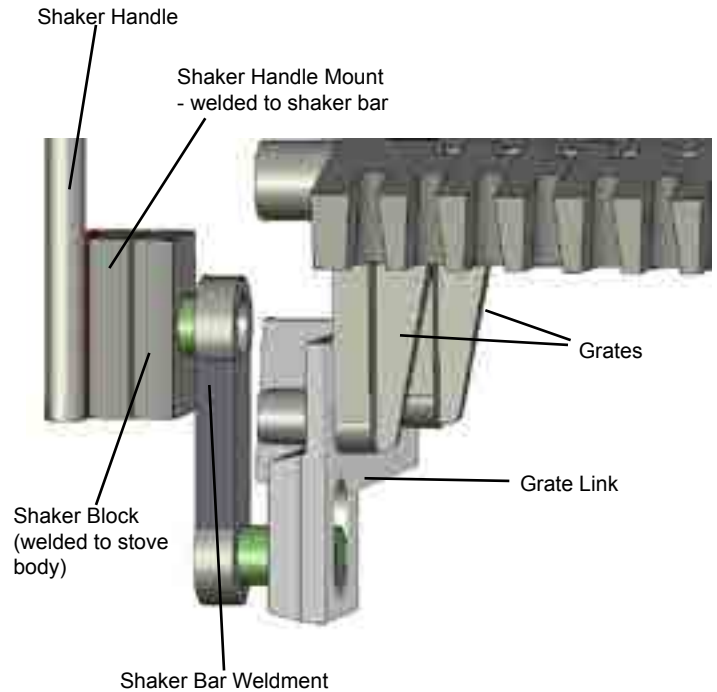

The next step is to install the glass and trim. Start by placing the glass frame face-down on a flat surface. Be sure the glass itself has the gasketing installed on the shorter ends only. The non gasketed top and bottom allow for air-wash and secondary air. Lay the glass into the frame, Now lift the load door off of the stove and lay it down onto the glass frame. Secure the frame to the door using (4) Flange-head bolts provided. While the door is still laying flat, install the top trim onto the door with (2) Hex-head bolts.



The coil spring handles slip onto the latches and the shaker handle. Push while turning to install.

VENTING

3.1 TYPES OF CHIMNEYS

The chimney is one of the most important, yet most neglected and misunderstood portion of any solid fuel burning installation.

We do not recommend that the stove be connected to a chimney shared by other heating devices.

THE STOVE MUST BE CONNECTED TO ITS OWN TILE-LINED FLUE. A MINIMUM FLUE SIZE OF 8" X 8" IS NECESSARY FOR PROPER OPERATION AND APPROVED FOR ALL FUELS.

NO OTHER APPLIANCES SHOULD BE VENTED TO THIS FLUE!

CAUTION: THE CHIMNEY MUST BE A CLASS 'A' CHIMNEY IN GOOD OPERATIONAL CONDITION.

NOTE; THE USE OF ALUMINUM TYPE 'B' GAS VENT FOR SOLID FUELS IS UNSAFE AND PROHIBITED BY THE NATIONAL FIRE PROTECTION ASSOCIATION CODE.

There are three types of Class "A" Chimneys:

- A. Masonry with tile liner to include brick or stone. It must be supported on grade level foundation.
- B. Insulated Class "A" manufactured chimney, listed or certified by a national test agency.
- C. Triple Wall Metal Class "A" chimney, listed or certified by a national test agency.

If your masonry chimney has not been used for some time, have it inspected by a qualified person (building inspector, fire department personnel, etc.). If a listed or certified manufactured chimney is to be used, make certain it is installed in accordance with the manufacturer's instructions and all local and state codes. (See Fig. F & G, note roof clearance.)

3.2 COMMON CHIMNEY PROBLEMS

In order to have a proper operating solid fuel heating system, the chimney must be capable of providing the draft required.

The minimum required draft is .06 inches w.c. (water column). This must be measured using a draft gauge.

If the chimney cannot supply this constant draft, the unit will not operate properly.

In some installations, a barometric draft regulator may be used and properly adjusted to compensate for excessive draft.

REASONS FOR INSUFFICIENT DRAFT READINGS:

- A. Leaky Chimney - Air leaking in around a loose fitting clean-out door, flue pipes not tight at the joints, improper plug openings or defective masonry.
- B. Chimney Improper Height - Chimney does not extend through the roof high enough to promote sufficient draft or causes a down drafting condition to take place. Chimney should be 2 feet higher than anything 10 feet around it! (See Fig. H)
- C. Obstruction In The Chimney - Check prior to use by holding a mirror in chimney clean-out door. This will give a view of the chimney.
- D. Trees or Other Topographical Barriers - Impeding the chimney's operation or causing a down draft condition to exist. This can also be caused by adjacent buildings or the roof of the same structure where the chimney is not high enough. (See Fig. H.)

NOTE: THE CHIMNEY ON THE HOUSE ILLUSTRATED IS TOO LOW. IT SHOULD BE RAISED TO COMPENSATE FOR DRAFTS.

- E. Chimney Size - Chimney is not properly sized to adequately vent the appliance. It is either too small or too large.
- F. Chimney Offsets - Chimneys with offsets should not be used. They cause an obstruction to draft as well as a place for debris to collect.

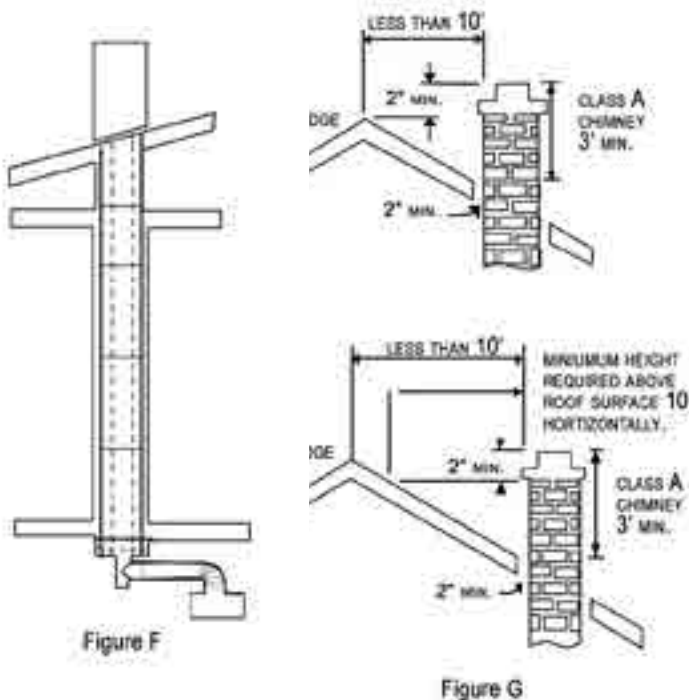

Figure H

VENTING

G. Elbow Restrictions - The flue pipe is connected to the chimney with too many elbows, reducing the draft the chimney can provide.

H. Multiple Venting - No more than one device shall vent into the same chimney flue.

THE MOST IMPORTANT THING TO REMEMBER ABOUT CHIMNEYS IS THEIR NEED FOR MAINTENANCE AND CLEANING. IF CHIMNEYS ARE NOT CLEANED ON A FREQUENT BASIS, IT WILL AFFECT THE DRAFT, AS WELL AS BEING A CONTRIBUTING CAUSE TO A CHIMNEY FIRE.

CAUTION! ANYTIME YOU HAVE A CHIMNEY FIRE, THE FOLLOWING POINTS SHOULD BE OBSERVED:

- Be sure everyone is out of the house.
- Call the fire department.
- Close down draft control on the stove.

AFTER THE FIRE IS EXTINGUISHED, DO NOT USE THE CHIMNEY UNTIL A QUALIFIED PERSON HAS INSPECTED YOUR CHIMNEY.

3.3 WHAT TO DO WHEN YOU HAVE A PROBLEM.

A. Smoke Puffs From Your Stove.

1. Check the chimney draft. With a good fire burning, the chimney should supply .06 " updraft.
2. Check draft controls for proper operation.
3. Check the chimney and be sure it is clean.
4. Chimney may be too low. Increase the height. Make sure the chimney is structurally sound.
5. Add more air to the room. Your home may be so airtight that not enough oxygen is reaching the fire.
6. **REMEMBER**, open the draft controls and open the fire door slightly before recharging the fire chamber or checking the fire.

SPECIAL WARNING: NEVER OPERATE YOUR STOVE WITH THE FIRE OR ASH DOOR OPEN!

7. Check the insert wings to be certain that there is an air tight seal between the wings and the fireplace front.
8. Check the ashes. Ash pan and ash compartment may be overloaded with ashes.
9. Check your chimney for down drafts. This is caused by air currents being deflected down the chimney from higher objects, such as trees, buildings and hills. This problem can usually be corrected with an open-vented chimney cap.
10. Make sure the chimney clean-out door is tightly closed and sealed.
11. If other fuel burning devices are connected to the chimney, they may be causing draft problems. This must be corrected by your heating contractor.

3.4 CHIMNEY DETAILS

Chimney Liners - Most of the customer inquiries received are problems caused by poor, or in some cases, excessive draft. A result of poor draft could be creosote, back-puffing, and smoky firebox when loading. Indications of excessive draft are burning too much fuel and high stack temperatures.

The most common cause of poor draft is an improperly sized flue liner. We recommend that the chimney liner's inside dimensions be at least as large as the appliance's collar size.

TO SUMMARIZE --A HEATING UNIT CAN PERFORM ONLY AS WELL AS ITS VENTING SYSTEM WILL ALLOW IT.

ELECTRICAL - WIRING DIAGRAM

4.1 WARNINGS

Turn off electric power at fuse box or circuit breaker panel before making any line voltage connections. Follow local electrical codes. Be sure to route power so that it doesn't come in contact with the stove.

IMPORTANT! ALL WIRING SHOULD BE DONE IN ACCORDANCE WITH LOCAL AND STATE CODES.

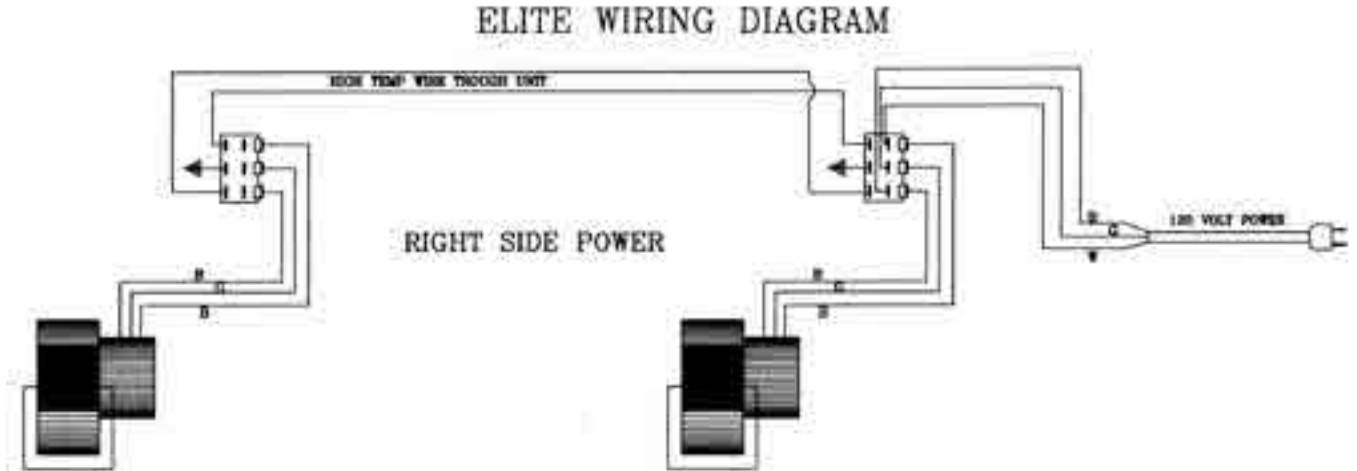

NOTE - THE MIDDLE HORIZONTAL ROW OF TERMINALS SHOULD HAVE ONLY GREEN (GROUND) WIRES

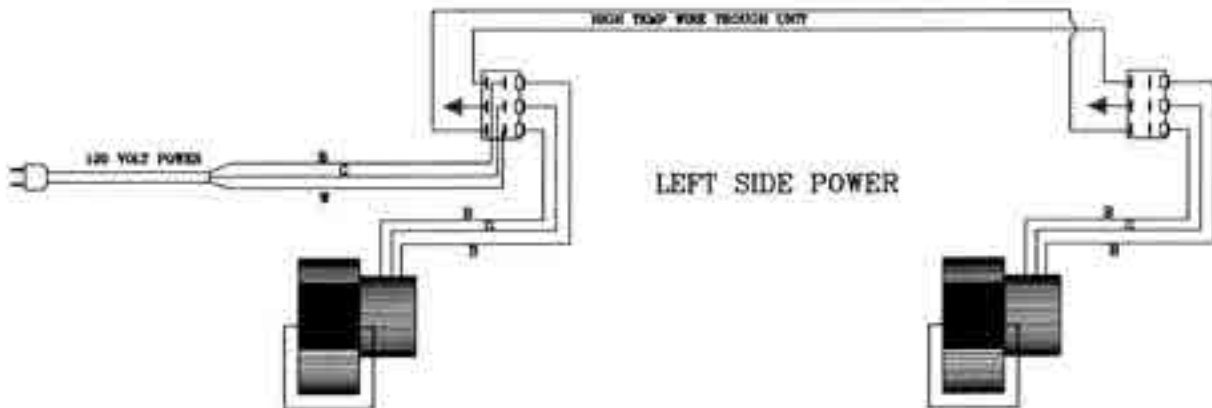

GRATES & WARNINGS

Section 5

5.1 GRATE SYSTEM

A. Heavy-duty cast iron grate system - The functions of a grate system are to support the coal and at the same time provide air flow through the grates to the coal. Harman® grates have a maximum amount of air flow to produce an even burning fire. Another function is to remove the ash from the coal bed by grinding, breaking, or shaking them through the grates. Harman® grates provide a variable amount of grinding action, this action is controlled by the movement of a long shaker lever located on the left side of the stove.

B. Burns three sizes of anthracite coal - You can burn pea, nut, or stove coal on these grates with no changes necessary.

C. Warnings

1. IMPORTANT! When shaking is complete, turn the shaker until the grates are flat and horizontal.

2. Keep the ash drawer empty! Ash buildup can damage your grates. If ash builds under and against the grates, it will cause the air flow to be stopped or lessened. This condition will cause warping of the grates.

NOTE: Grates damaged in this way are easily detected by the great amount of damage caused to them. Please read your warranty to see limits of liability in cases of abuse.

3. Fresh ashes are hot! Never put hot ashes in contact with any flammable material. Store hot ashes in a metal container outside of your home. Allow the ashes to cool then dispose of properly.

Section 6:

WARNINGS & SPECIAL INSTRUCTIONS

6.1 Blower:

Your Harman® insert is provided with a blower system. This system is not only designed to distribute heat throughout your home but serves a critical need in the design system of the insert. Extremely high heats are generated inside the insert and can do much damage to the heat exchanger and baffle system. Surface temperatures of 500 degrees F. can be associated with internal temperatures as high as 1000 degrees F. or more. Temperatures at these levels for extended periods of time, can damage internal parts of the insert. Inserts, unlike free standing stoves, have no way to release built up heat into your home except through its internal passages. Free standing stoves radiate their heat freely into the air.

Use of the blowers is not only critical to the life of the insert, but much heat efficiency is lost if the design of the system is defeated by not using the blowers. The heat which is trapped in the fireplace may amount to as much as 75% of the total output of the insert. This should make it easy to see that fuel is being wasted if the blowers are not used.

Harman® has gone to great lengths to design this insert to have the best balance of features, looks, and price available in the market place today. We also stand strongly behind our warranty as long as the warranty claim falls within the stated liability of that warranty. Abuse and neglect are terms outside the liability of Hearth & Home Technologies in matters of warranty repair or replacement. To clarify, overfiring is considered abuse and will not be eligible for warranty repair. Non-use of the blower system is one of the major causes of overfiring in insert use. An overfire situation is considered to exist when the surface temperature of the insert exceeds 500 degrees F..

6.2 NOTE: It is your responsibility to follow all state and local codes when installing your insert.

6.3 It is suggested that you have a qualified stove installer install your insert.

6.4 It is your responsibility to make sure that proper clearances to combustible materials is maintained when installing your insert.

NOTE: Safe clearance to combustibles is 36 inches. If you have a flammable mantel and proper clearance cannot be maintained, a metal shield must be installed to protect the mantel.

6.5 Have your fireplace and chimney inspected by a qualified chimney sweep to make sure your fireplace and chimney are safe and in good operating condition.

6.6 Make sure your chimney has an adequate draft of 0.06 inches of water column on a draft meter.

MAINTENANCE & OPERATION

Section 7: PREVENTIVE MAINTENANCE INSTRUCTIONS

7.1 PERIODIC AND NORMAL EVERYDAY MAINTENANCE

Grates- Keep ash drawer emptied. Failure to do this will cause grates to warp.

CAUTION! Before cleaning the chimney and smoke pipe, be sure the fire is out and the inside of the stove is cool.

Avoid chimney fires! On a regular schedule, check for creosote and soot buildup in the chimney, it must be kept clean. Keep a professional chimney sweep in mind if you have access to one.

Steel brushes are the safest for cleaning metal surfaces. Salt solutions and some chemicals may damage metal surfaces. Do not overfire your stove. Do not burn anything that combusts in seconds. Excessive flue temperatures may result thereby igniting creosote.

To clean the chimney, obtain a stiff brush with an extendable handle and insert the brush into the chimney from the top. Continue the brushing and sweeping downward until the entire length of the chimney is cleaned.

After cleaning the chimney, the debris will be at the bottom of the chimney at the clean-out door, sweep the debris out into a metal container.

Section 8: OPERATING INSTRUCTIONS

8.1 STARTING A COAL FIRE

Take about eight sheets of newspaper, crumble them into balls and place on top of the grates. Next, lay fine kindling on top of the paper. This kindling must be dry and no larger than 3/4" in diameter. Layer the kindling in a criss-cross fashion to allow good air flow. Open the draft control fully and light the paper just inside the door. Now, close the loading door and allow the kindling to catch fire. After a few minutes, open the loading door an inch or two for a few seconds before opening completely. This method will allow smoke to clear away from the door opening before the loading door is completely opened.

Add small, compact pieces of hardwood when the kindling is burning hot. Keep the draft controls fully open to establish a hot fire quickly. The ash door also may be opened during start-up to accelerate the initial burn, but must be closed again after a fire has been established to prevent overfiring the insert.

When a substantial bed of red wood coals are built-up, start adding coal (pea or nut is preferred to stove coal for starting) in small amounts at a time. Keep the draft control open.

Continue adding small amounts of coal until there is a solid bed of burning coal. Do not add too much at one time. Allow sufficient time between each small loading (at least 5-10 minutes), so that each loading has time to ignite thoroughly before the next load is put in. When a substantial bed of burning coals has been established, fill the stove to the top of the firebrick. A deep bed of coal always will burn more satisfactorily than a shallow bed.

When most of the wood is burned and the coal is completely ignited (usually 5-10 minutes or less after filling the stove), the draft control should be turned down to the proper operating level. **(If the ash door has been opened, it must be closed to prevent overfiring, which can cause dangerously high temperatures.)**

8.2 LOADING

Coal should never be added unless there is a reasonably hot fire. The coal bed should be bright and vigorous.

If the fire is burning hot and there is a deep bed of coals, full loads of coal can be added at anytime. However, if there is not a deep bed of coals, it is best to add small amounts of coal at first.

OPERATION

8.3 INCREASING HEAT FROM A LOW FIRE

Every effort should be made not to let a coal fire burn too long so that the fire has started to die. This will cause the reloading process to be much longer, and there is a good possibility of losing the fire.

Do not shake or stir with a low fire.

Open the draft control wide or open the ash cleanout door to get the maximum draft, but make sure you close the ash door as soon as a reasonable fire has been established.

Start adding small amounts of coal, and follow the same procedures as in paragraphs 3 and 4 in section 8.1.

When the new coal is thoroughly ignited or there is a substantial bed of hot coals, the stove may be shaken thoroughly. Be sure to shake down all dead ashes (**but do not overshake**). As soon as you see a sprinkle of red coal ash **STOP!**

After shaking, keep the bottom draft control open until you are sure the fire is continuing to burn hot, then turn the draft control down to the proper operating level. If the ash door has been opened, be sure to shut it (serious damage can result if the stove is run for extended periods with the ash door open).

NEVER LEAVE THE ROOM WITH THE BOTTOM DOOR OPEN.

NEVER LEAVE THE INSERT BURN FOR EXTENDED PERIODS WITH BOTTOM DOOR OPEN.

A SERIOUS OVERHEAT COULD OCCUR AND VOID YOUR WARRANTY. IT IS YOUR RESPONSIBILITY TO NEVER ALLOW THE TEMPERATURE OF YOUR INSERT TO EXCEED 500 DEGREES F. OPERATION ABOVE THIS TEMPERATURE WILL VOID YOUR WARRANTY.

Count the exact number of turns from fully shut to the normal operating positions so that you can adjust the stove to the exact level of heat output and length of burn you desire.

8.4 SHAKING

Shaking should be done only when there is a hot fire.

The frequency of shaking will depend on the type of stove and degree of burning. Shaking should be done at least once a day, and preferably twice a day.

Best results from shaking with Harman® grates will occur if short "choppy" strokes are used rather than long, even strokes.

The amount of shaking is critical. Too little or too much, either can result in the extinguishing of a fire due to blocked air flow. The proper amount normally occurs when red coals first start to drop through onto the bed of ashes.

8.5 DRAFT CONTROLS

The heat output of the coal is controlled by the primary draft control on the bottom door. Experience will dictate the proper settings for heat requirements.

Coal responds very slowly to changes in the draft settings. Because of this slow response time, over-correcting is a common problem. When changes in heat output are needed, make only small changes in the draft setting and wait for the temperature to stabilize.

8.6 ASHES

Ashes should never be allowed to accumulate in the ash pan so that they in any way impede the flow of combustion air to the fire. Excess ash accumulation can cause the fire to go out and also can cause severe damage to the grates because of absence of a cooling flow of air beneath them.

Ashes should be placed in a metal container with a tight fitting lid. The closed container of ashes should be placed on a non-combustible floor or on the ground, well away from all combustible materials, pending final disposal. If the ashes are disposed of by burial in soil or otherwise locally dispersed, they should be retained in the closed container until all cinders have thoroughly cooled.

CAUTION!

ASHES SHOULD NEVER BE ALLOWED TO ACCUMULATE ABOVE THE TOP OF THE ASH PAN. ASHES IN CONTACT WITH THE BOTTOM OF THE GRATES ACT AS AN INSULATOR, INTENSIFYING THE HEAT ON THE GRATES AND COULD CAUSE THEIR WARPAGE. WITH AN EXCESSIVE ASH BUILDUP, PRIMARY COMBUSTION AIR IS RESTRICTED, THUS, THE UNIT'S OUTPUT COULD BE REDUCED.

GRATES DAMAGED IN THIS WAY ARE EASILY RECOGNIZED BY THE EXTREME DAMAGE CAUSED TO THE GRATES.

PLEASE REFER TO YOUR WARRANTY TO SEE THE LIMITS OF LIABILITY IN CASES OF ABUSE OR NEGLECT.

SAFETY

8.7 SAFETY

Whenever a loading door is opened, it should always be cracked slightly to allow oxygen to enter and burn any combustion gases that are present before fully opening. Failure to do this could result in sudden ignition of the unburned gases when the door is opened.

A stove should never be filled with excess coal so that the flue gas exit is blocked or impeded in any way. Burning coal generates carbon monoxide. **If the flue gas exit is blocked, the carbon monoxide can be forced out of the stove into the room, with possibly fatal consequences.**

NOTE: A STOVE SHOULD NEVER BE LEFT UNATTENDED WITH THE ASH DOOR OPEN.

WITH THE EXCEPTION OF THE START-UP PERIOD, THE ASH PAN DOOR SHOULD NEVER BE LEFT OPEN.

Serious damage to the stove can occur from overheating.

Coal stoves should not be installed in any chimney that has had a history of back-drafting or flow reversal. These conditions can cause improper draft, resulting in carbon monoxide entering the house rather than being drawn up the chimney.

REMEMBER! COAL GASES ARE TOXIC!

Sulfur dioxide, sulfur trioxide and other ions released from coal burning may corrode stainless and masonry chimneys, and even terra cotta chimney liners. Coal with high sulfur content will destroy chimneys especially fast if soot sits in the flue for extended lengths of time. It is important to clean chimneys regularly.

Hearth & Home Technologies LIMITED LIFETIME WARRANTY

Hearth & Home Technologies, on behalf of its hearth brands ("HHT"), extends the following warranty for HHT gas, wood, pellet, coal and electric hearth appliances that are purchased from an HHT authorized dealer.

WARRANTY COVERAGE:

HHT warrants to the original owner of the HHT appliance at the site of installation, and to any transferee taking ownership of the appliance at the site of installation within two years following the date of original purchase, that the HHT appliance will be free from defects in materials and workmanship at the time of manufacture. After installation, if covered components manufactured by HHT are found to be defective in materials or workmanship during the applicable warranty period, HHT will, at its option, repair or replace the covered components. HHT, at its own discretion, may fully discharge all of its obligations under such warranties by replacing the product itself or refunding the verified purchase price of the product itself. The maximum amount recoverable under this warranty is limited to the purchase price of the product. This warranty is subject to conditions, exclusions and limitations as described below.

WARRANTY PERIOD:

Warranty coverage begins on the date of original purchase. In the case of new home construction, warranty coverage begins on the date of first occupancy of the dwelling or six months after the sale of the product by an independent, authorized HHT dealer/ distributor, whichever occurs earlier. The warranty shall commence no later than 24 months following the date of product shipment from HHT, regardless of the installation or occupancy date. The warranty period for parts and labor for covered components is produced in the following table.

The term "Limited Lifetime" in the table below is defined as: 20 years from the beginning date of warranty coverage for gas appliances, and 10 years from the beginning date of warranty coverage for wood, pellet, and coal appliances. These time periods reflect the minimum expected useful lives of the designated components under normal operating conditions.

Warranty Period		HHT Manufactured Appliances and Venting							Components Covered
Parts	Labor	Gas	Wood	Pellet	EPA Wood	Coal	Electric	Venting	
1 Year		X	X	X	X	X	X	X	All parts and material except as covered by Conditions, Exclusions, and Limitations listed
2 years				X	X	X			Igniters, electronic components, and glass
		X	X	X	X	X			Factory-installed blowers
				X					Molded refractory panels
3 years				X					Firepots and burnpots
5 years	1 year			X	X				Castings and baffles
7 years	3 years		X	X	X				Manifold tubes, HHT chimney and termination
10 years	1 year	X							Burners, logs and refractory
Limited Lifetime	3 years	X	X	X	X	X			Firebox and heat exchanger
90 Days		X	X	X	X	X	X	X	All replacement parts beyond warranty period

See conditions, exclusions, and limitations on next page.

WARRANTY CONDITIONS:

- This warranty only covers HHT appliances that are purchased through an HHT authorized dealer or distributor. A list of HHT authorized dealers is available on the HHT branded websites.
- This warranty is only valid while the HHT appliance remains at the site of original installation.
- This warranty is only valid in the country in which the HHT authorized dealer or distributor that sold the appliance resides.
- Contact your installing dealer for warranty service. If the installing dealer is unable to provide necessary parts, contact the nearest HHT authorized dealer or supplier. Additional service fees may apply if you are seeking warranty service from a dealer other than the dealer from whom you originally purchased the product.
- Check with your dealer in advance for any costs to you when arranging a warranty call. Travel and shipping charges for parts are not covered by this warranty.

WARRANTY EXCLUSIONS:

This warranty does not cover the following:

- Changes in surface finishes as a result of normal use. As a heating appliance, some changes in color of interior and exterior surface finishes may occur. This is not a flaw and is not covered under warranty.
- Damage to printed, plated, or enameled surfaces caused by fingerprints, accidents, misuse, scratches, melted items, or other external sources and residues left on the plated surfaces from the use of abrasive cleaners or polishes.
- Repair or replacement of parts that are subject to normal wear and tear during the warranty period. These parts include: paint, wood, pellet and coal gaskets, firebricks, grates, flame guides, batteries and the discoloration of glass.
- Minor expansion, contraction, or movement of certain parts causing noise. These conditions are normal and complaints related to this noise are not covered by this warranty.
- Damages resulting from: (1) failure to install, operate, or maintain the appliance in accordance with the installation instructions, operating instructions, and listing agent identification label furnished with the appliance; (2) failure to install the appliance in accordance with local building codes; (3) shipping or improper handling; (4) improper operation, abuse, misuse, continued operation with damaged, corroded or failed components, accident, or improperly/incorrectly performed repairs; (5) environmental conditions, inadequate ventilation, negative pressure, or drafting caused by tightly sealed constructions, insufficient make-up air supply, or handling devices such as exhaust fans or forced air furnaces or other such causes; (6) use of fuels other than those specified in the operating instructions; (7) installation or use of components not supplied with the appliance or any other components not expressly authorized and approved by HHT; (8) modification of the appliance not expressly authorized and approved by HHT in writing; and/or (9) interruptions or fluctuations of electrical power supply to the appliance.
- Non-HHT venting components, hearth components or other accessories used in conjunction with the appliance.
- Any part of a pre-existing fireplace system in which an insert or a decorative gas appliance is installed.
- HHT's obligation under this warranty does not extend to the appliance's capability to heat the desired space. Information is provided to assist the consumer and the dealer in selecting the proper appliance for the application. Consideration must be given to appliance location and configuration, environmental conditions, insulation and air tightness of the structure.

This warranty is void if:

- The appliance has been over-fired or operated in atmospheres contaminated by chlorine, fluorine, or other damaging chemicals. Over-firing can be identified by, but not limited to, warped plates or tubes, rust colored cast iron, bubbling, cracking and discoloration of steel or enamel finishes.
- The appliance is subjected to prolonged periods of dampness or condensation.
- There is any damage to the appliance or other components due to water or weather damage which is the result of, but not limited to, improper chimney or venting installation.

LIMITATIONS OF LIABILITY:

- The owner's exclusive remedy and HHT's sole obligation under this warranty, under any other warranty, express or implied, or in contract, tort or otherwise, shall be limited to replacement, repair, or refund, as specified above. In no event will HHT be liable for any incidental or consequential damages caused by defects in the appliance. Some states do not allow exclusions or limitation of incidental or consequential damages, so these limitations may not apply to you. This warranty gives you specific rights; you may also have other rights, which vary from state to state. EXCEPT TO THE EXTENT PROVIDED BY LAW, HHT MAKES NO EXPRESS WARRANTIES OTHER THAN THE WARRANTY SPECIFIED HEREIN. THE DURATION OF ANY IMPLIED WARRANTY IS LIMITED TO DURATION OF THE EXPRESSED WARRANTY SPECIFIED ABOVE.

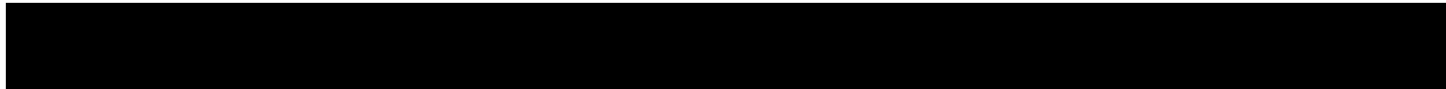

At Harman®, we build each product to a standard, not a price.



(Signature of Boxer)

Your premium quality hearth product designed and assembled by the experienced and skilled members at Harman® in Halifax, PA, USA.

HARMAN®

BUILT TO A STANDARD, NOT A PRICE

Proudly Printed On 100% Recycled Paper

