

CH-400-A

**OPERATION
MANUAL**

chimp®

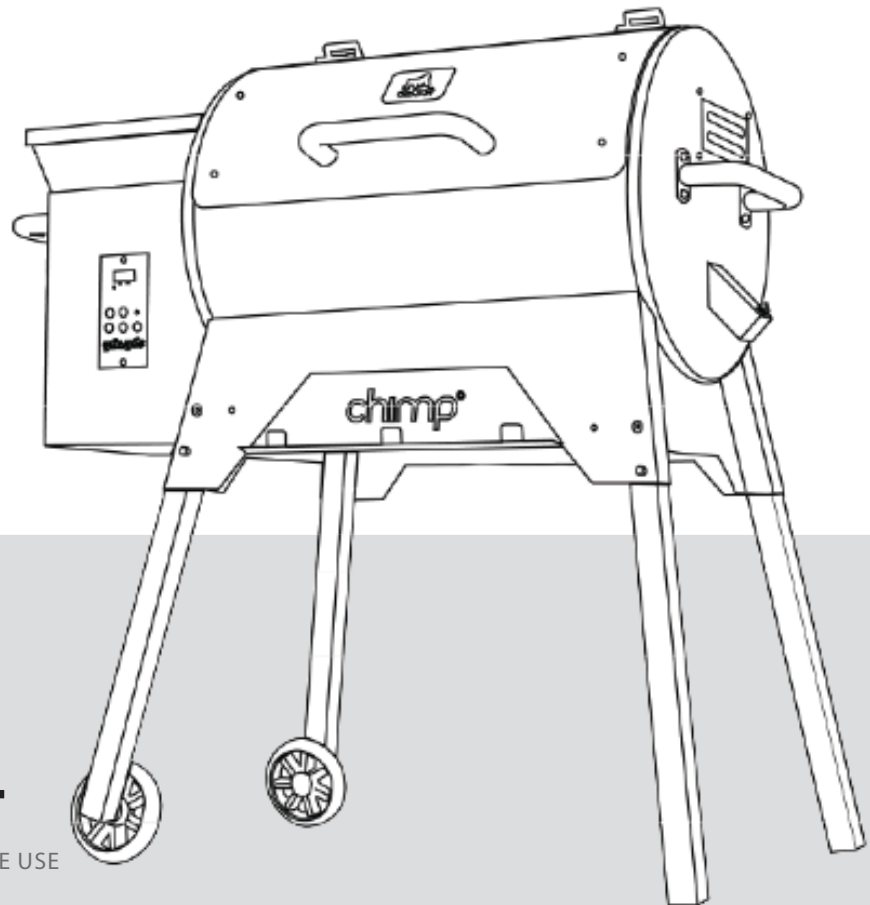

WOOD PELLET GRILL

SAVE THIS MANUAL FOR FUTURE USE

SAFETY PRECAUTIONS



SAFETY NOTICE: FOR OUTDOOR USE ONLY!

WARNING: Electric shock can kill or result in serious injury. Precautions should always be followed to reduce the risk of fire, electric shock, and injury.

OUR STORY

True story: Two men on a fishing trip, chowin' down at camp on a plate of ribs. One looks over at the grill (he's the industrial designer) and says, "Why do all those grills look the same, big ole barrel cut in half?" The other, a metalsmith by trade, answers, "Because we haven't built one." That's when the lightbulb went off. Why not design and build a smoker-grill that stands apart, literally, from the crowd? Hundreds of design hours later, the Grilla was born.

Fast forward a few successful years: same two guys, same idea. Only this time, bring a rock-solid, proven smoker-grill to the market using the same streamlined business model that delivers savings to the consumer. Design the grill to efficiently feed you and your friends or the entire neighborhood. Make it easy to use and good looking. Hundreds of design hours later, the Chimp was born.

Just like a silverback is the proven and respected leader in a family of mountain gorillas, so too is Chimp the patriarch of the Grilla family of smoker-grills. No confusing Chimp with any of these flimsy me-too grills. Been there, done that.

All Grilla products, including pellets, sauces and accessories, are available direct to the hungry consumer. No fat in this business model, just pure value meal after delicious meal. Not bad for two fishing buddies. Enjoy!



TABLE OF CONTENTS

INTRODUCTION

Safety Information	4
About Your New Chimp	5
Assembly	6

OPERATION

Chimp 101: How to Operate Your Chimp Getting Started Operating Your Chimp	9
Controller Operation	10
Maintenance and Care	12
Approved Fuel: Food Grade Wood Pellets	13
Parts Diagram	14
Troubleshooting and FAQ	16
Limited Warranty Information	17

FAILURE TO FOLLOW THIS OPERATIONAL MANUAL
IN ITS ENTIRETY WILL VOID ALL WARRANTIES.

SAFETY INFORMATION

Congratulations on your purchase of a Chimp grill! Used and cared for properly, this grill will give you years of enjoyment and trouble-free operation. Before assembling and using your new grill, please review the information in this manual thoroughly. In it, you'll find many useful tips to help maximize your Silverbac's long list of benefits and features.

Your Chimp is much more than just a traditional grill. In fact, you can cook almost anything on this grill. Try pizza, marinated vegetables, casseroles, or bread — or, stick to the basics like steaks, roasts, hams, pork chops or tenderloins, wild game, and poultry.

Using advanced technology, the unit adjusts the rate at which pellets are introduced into the fire pot in order to keep the temperature consistent and predictable. Because of this, the Chimp is the easiest and most convenient way to grill, cook, bake, slow smoke and roast food while also adding flavors that can only be generated by a wood fire. Set your grill's temperature and let it do the rest.

Thank you for choosing a Chimp Grill!

It's important that you read all of the safety information in this manual before operating your new Chimp grill.

- The unit is for outdoor use only. Never use the Chimp in an enclosed area.
- For safe assembly, use at least two people to unpack and assemble the grill.
- Keep young children and pets away from the grill while it's in use.
- Always use heat-resistant hand wear when touching or handling the grill while it's in use.
- Keep the grill at least two feet away from any combustible surface.
- Never use flammable liquids such as gasoline, charcoal lighter fluid, kerosene, or similar liquids to start or freshen the fire in your grill. Keep all such liquids well away from the unit while it is in use.
- Clean the grill on a regular basis. Clean the unit's drip tray and ensure that the grease drain is able to function properly (i.e., not on an uphill slope on a deck or patio). Should a grease fire occur, turn the grill off, unplug it, and then close the lid until the fire extinguishes.
- Never place flammable items in the grill's storage area.
- Install the service access panels (under the grill's pre-installed shelf and on the rear) before plugging the unit in. Always keep the unit's shelf-side louvers clear of any obstructions.
- Never put your hand in the pellet hopper or attempt to service any part of your Chimp while the unit is plugged in.
- Check your Chimp for fire pot obstructions occasionally. This will help maintain proper airflow.
- Position your grill on level ground. The grill should be kept as level as possible so that the grease flows into the trough and out into the can and also to ensure that the sensor reads grease catch evenly, as hot air displaced to one side or the other will cause irregular operation.
- Never move the unit while it is hot and/or in operation. Make sure the fire is completely out and that the grill is completely cold before being transported.
- Never move the Chimp when the pellet hopper is full. The unit can become top-heavy and may tip over if moved.
- Clean temperature sensor occasionally to ensure proper temperature readout.

ABOUT YOUR NEW CHIMP

Your Chimp grill is state-of-the-art and built with many innovative features, including:

- Alpha Smoke Controller
- Automatic lighting feature
- 180°F to 500°F in 5-degree increments

Exterior

- High-temperature durable textured powder coat.
- 15-pound hopper capacity.

Interior

- 340- sq. in. area in the lower rack and 121-sq. in. area in the upper rack. Grill grates made from .19-inch stainless steel rod.

Construction Features

- Seams are welded, powder coated, and caulked for triple redundant weather protection.
- Modular construction allows for individual component replacement. Component access panels for easy repairs.

Carton Contents

During shipping, some movement of parts and components may have taken place. Visually inspect all of the contents before assembling and inspect the entire grill once you remove it from the shipping carton. Be cautious of any sharp surfaces and use gloves during assembly. Never plug the grill in until it's completely assembled and ready to use.

- 1– pre-assembled grill body
- 2– stainless steel cooking grates
- 1– flame deflector
- 1– drip pan
- 1– drip grease can holder

ASSEMBLY

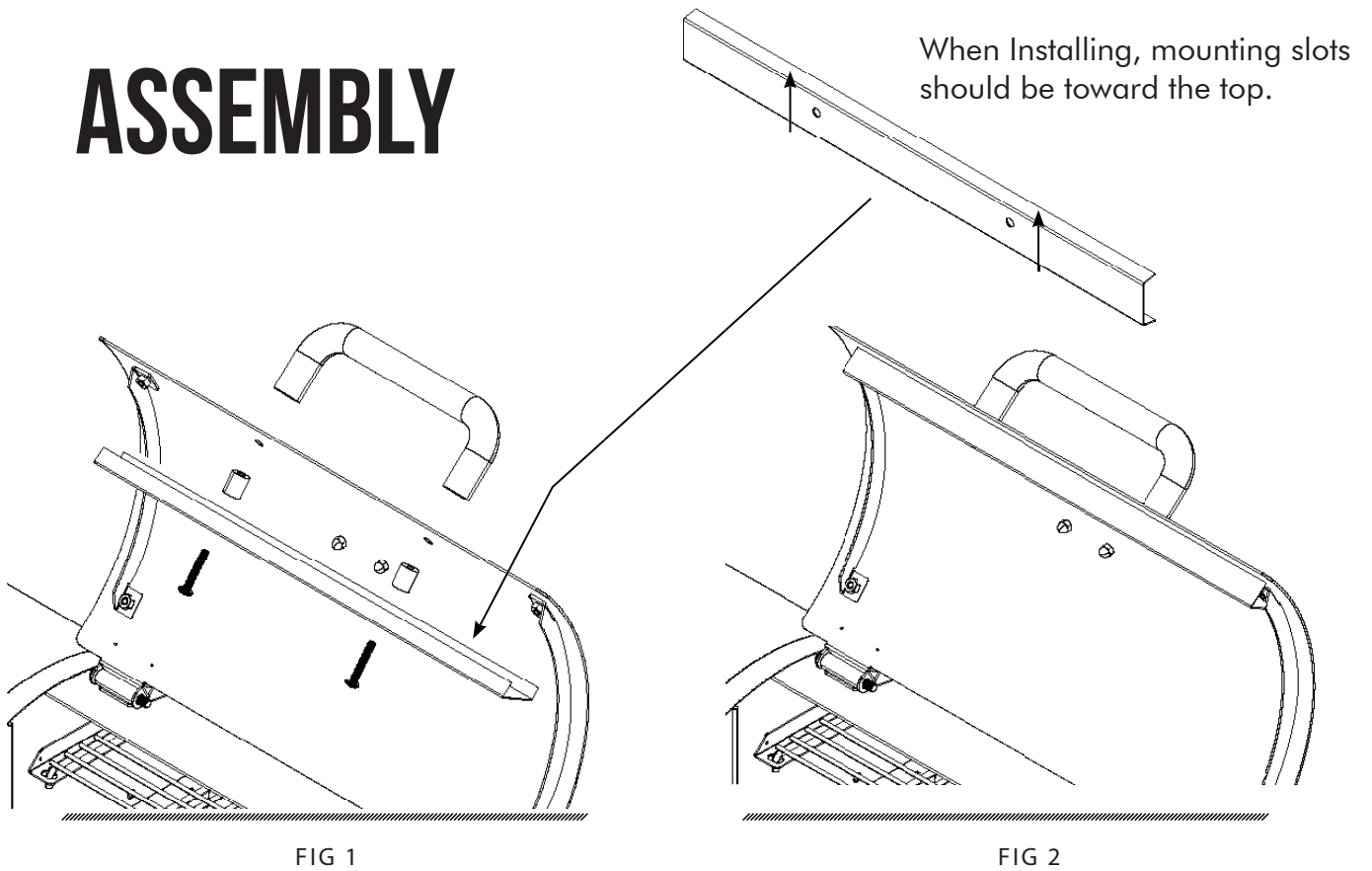

STEP 1 - Using the 2 longer 1/4" philips head screws supplied, and the aluminum spacer mount the smoke deflector and lid handle to the stainless steel lid.

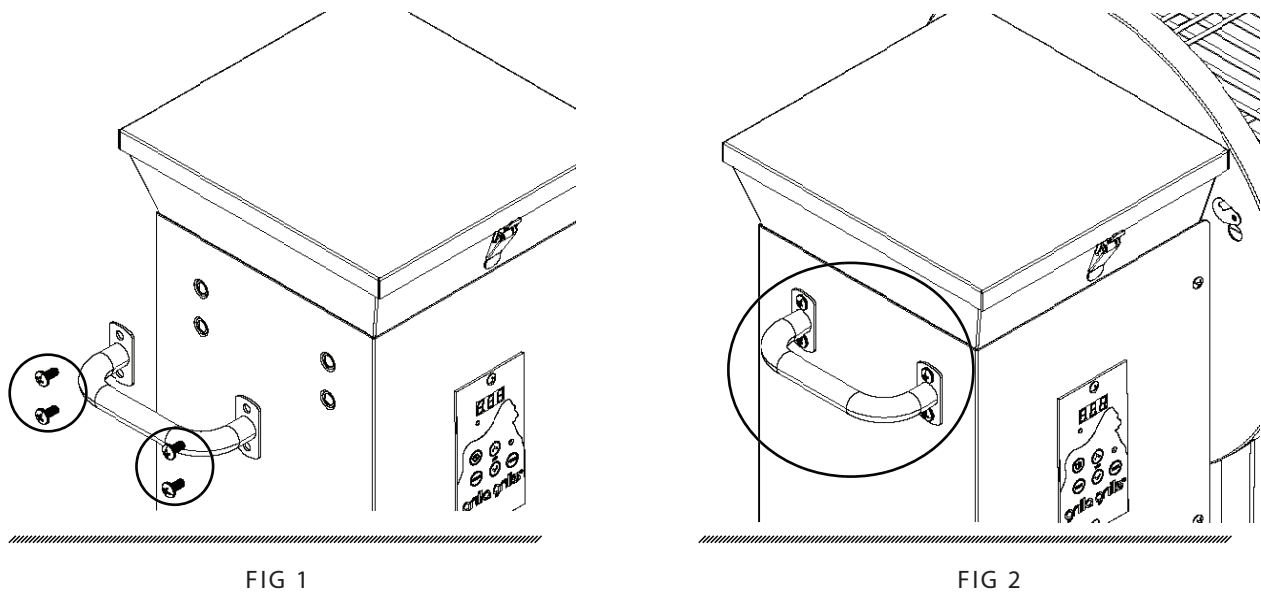

STEP 1 - Use the 4 shorter 1/4" philips head screws circled in FIG 1 to mount the hopper handle, Seen in FIG 2.

OPERATION

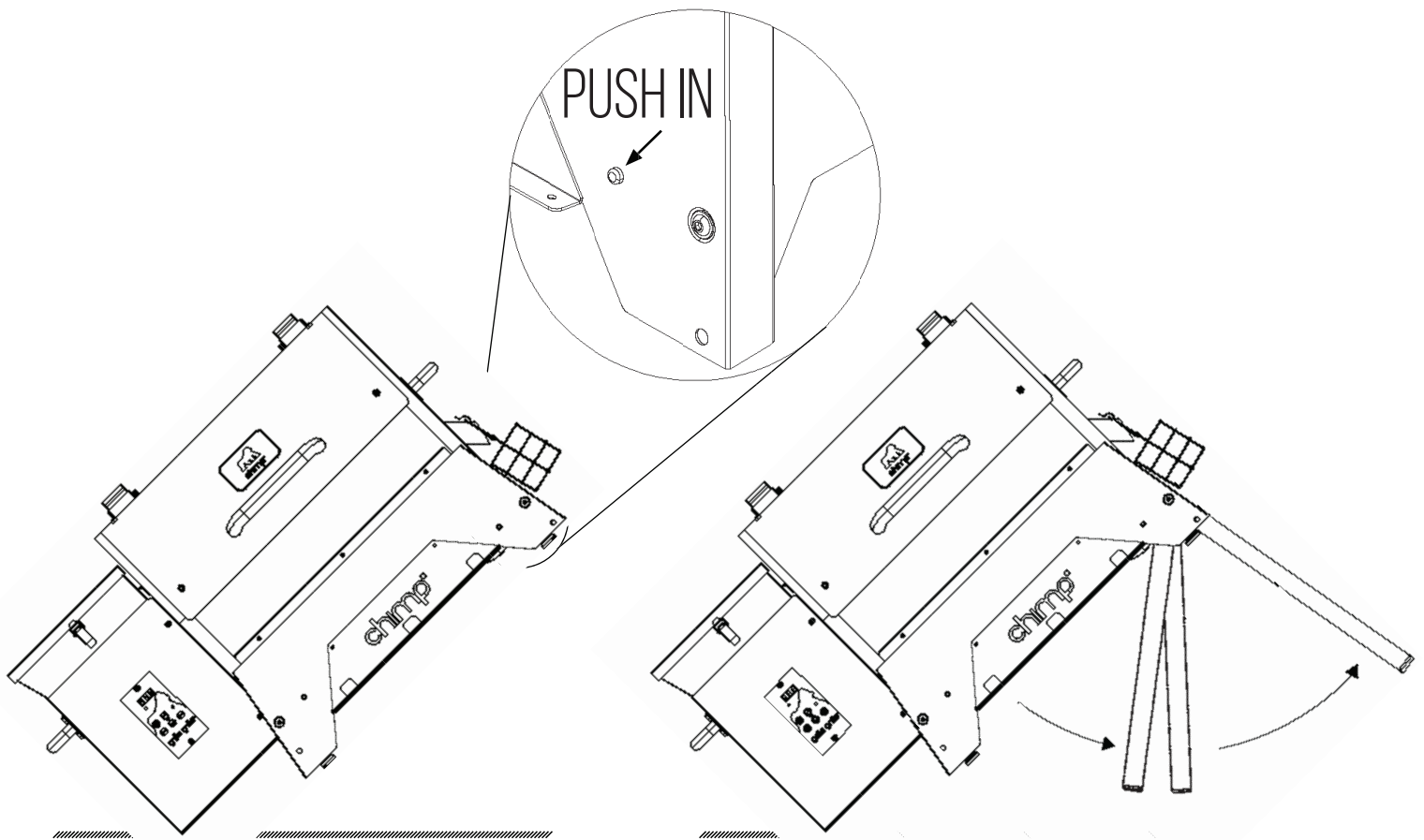

FIG 1

STEP 1 - Tilt grill up on the hopper edge illustrated in (FIG 1). Push in the metal detent on each side of the grill to release the two non-wheel legs (FIG 2). Make sure the detent clicks back into the downward position holes.

OPERATION (cont.)

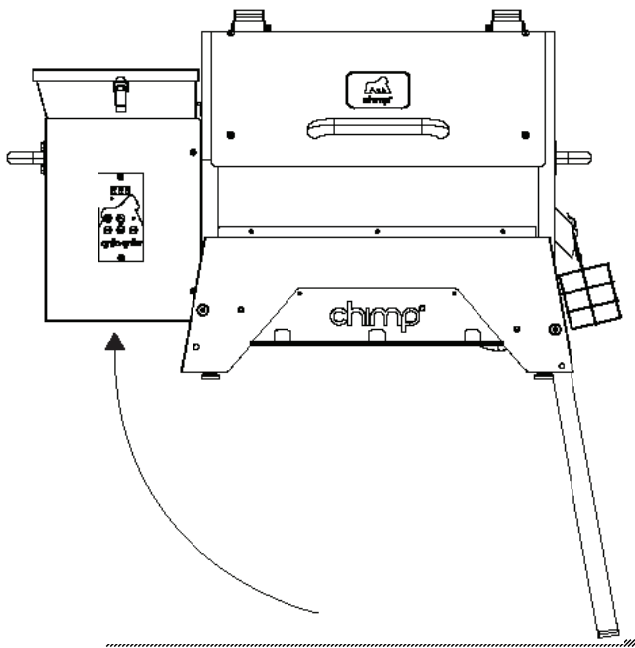
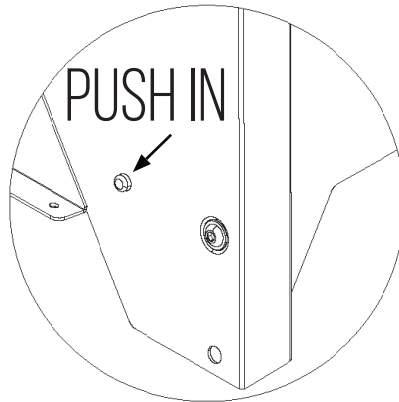

FIG 1

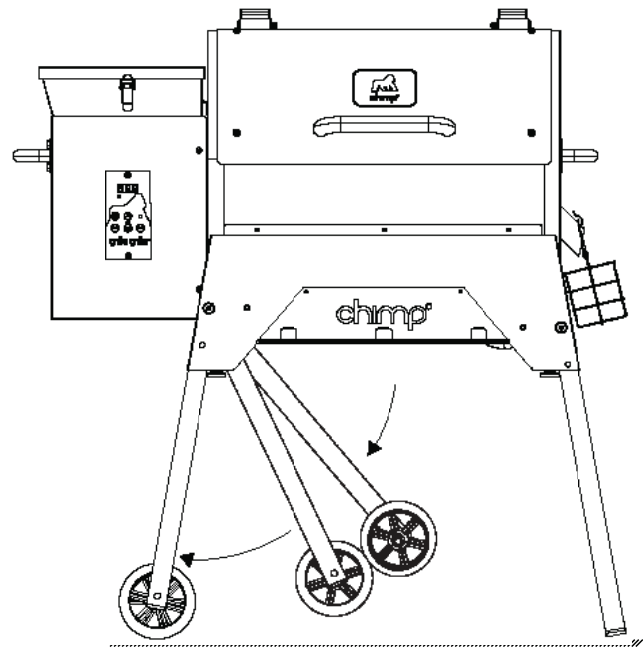

FIG 2

STEP 2 - Now lift hopper side using the handle on the hopper (FIG 1). Again push the metal detents on both sides of your grill to release the wheel legs, click them into place (FIG 2).

CHIMP 101:

How to Operate Your Chimp.

Follow these operating instructions exactly as stated to ensure safe and reliable operation. Carefully read this manual in its entirety before starting your Chimp for the first time.

NOTE: BEFORE COOKING ON YOUR Chimp FOR THE FIRST TIME, YOU WILL NEED TO CLEAN AND "SEASON" YOUR Chimp. Refer to "GETTING STARTED" below for further instructions. The high-temperature paint on the Chimp may take up to 30 minutes to fully cure. During this initial start up and seasoning, an odor that is not harmful may be evident.

Getting Started

You will need to season your Chimp before you cook on it for the first time:

1. Clean upper and lower cooking grates with soap and water.
2. Fill hopper with approved cooking pellets.
3. Plug Grill into 110 Volt AC grounded outlet.
4. For your first start, remove the Lower Cooking Grate (8), Grease Pan (6), and Heat Baffle (5).
5. Turn Grill on, and the igniter rod should turn a light red in 1 to 2 minutes (do not touch).
6. Once the pellets have traveled through the tube and have started dropping (roughly 2 to 4 minutes), turn OFF the grill.
7. Place components back in place and restart the grill by turning the grill on.
8. This procedure is not necessary again unless the grill runs out of pellets and it needs to have the tube "re-primed."
9. Set temperature to 450°F and let the grill run for 45 minutes.

Operating Your Chimp

1. Check hopper for debris and add pellets as necessary.
Warning — remove the grease can before movement of the grill to avoid spilling.
2. Open lid and turn on Grill. Close lid once fire has ignited.
3. Set to desired temperature (default is 250°F).
4. Once it's cooled completely, cover Chimp or put away to protect it from rain.
If cooking above 400°F, open lid and turn grill down to 225°F and let cool for 15 minutes prior to turning off.

 **WARNING:** Do not attempt to move Chimp while running.

CONTROLLER OPERATION

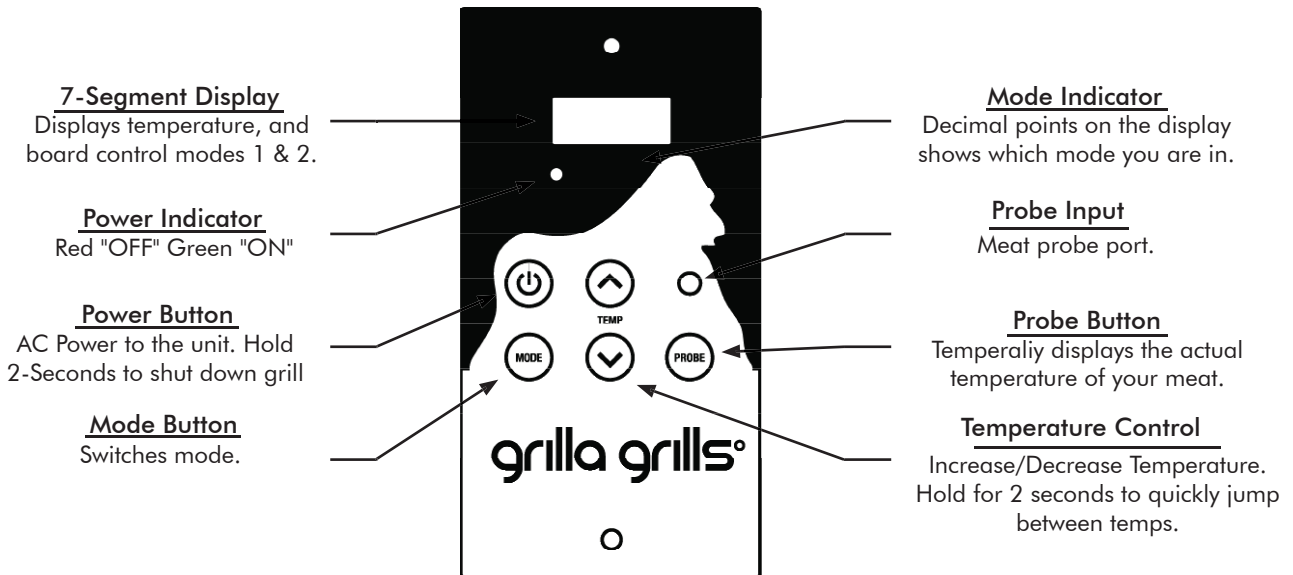

Power Button

- Starts "Ignition" Sequence
- Starts "Shutdown" Sequence (2 Second Hold)
- Resets Error codes

Temperature Setting Buttons

Moves temperature setting up or down in 5 degree increments from 180 to 500°F. Holding for 2 seconds will change temperature quickly. Default 250°F.

Probe Button

- When grill is on and probe is connected, pressing button will change readout to show the meat probe reading. This reading will display for 5 seconds. Then it will return to show the current grill temperature.

Ignition Sequence

When Power button is pressed:

- Igniter turns on and runs for 4 minutes. At 4 minutes if temp is 150°F, it turns off. If temp is below 150°F after 4 minutes, it stays on for 4 more minutes (8 total) then turns off.
- Auger turns on at 100% during the ignition stage then goes to normal temperature control operation.
- Fan turns continuously.
- Board displays current temperature. If below 110°F (likely), the display will be flashing until above 110°F. It has 10 minutes (ERL requirement) to get above this or it initiates ERL code.

CONTROLLER OPERATION (cont.)

Shutdown Sequence

When Power button is pressed for 2 seconds:

- Auger turns off.
- Fan continues to run for 5 minutes.
- Board displays C5, C4, C3, C2, C1 (minutes) then goes blank.

ErL (low temp) Code

- Grill temp was below 150°F for more than 10 minutes.

ErH (high temp) Code

- Grill temp reached 615°F.

FHi (food high) Code

- Food probe is above 225°F. Removing probe from socket returns board to normal read out.

MODE 1 PRECISION TEMP CONTROLLER

TO TURN CONTROLLER ON/OFF PRESS THE POWER BUTTON FOR 2 SECONDS PRESS AND HOLD THE "MODE" BUTTON TO ALTERNATE BETWEEN MODES

- YOUR GRILLS DEFAULT SETTING IS ALREADY OPTIMIZED FOR MOST TEMPERATURE RANGES. TO FINE TUNE EVEN FURTHER FOLLOW THE STEPS BELOW.

1. TO CHANGE SETTINGS PRESS AND HOLD THE **MODE, UP, AND DOWN** ARROWS FOR 2 SECONDS.

2. USING THE UP AND DOWN ARROWS ENTER YOUR DESIRED SETTING. HIT THE "MODE" BUTTON WHEN FINISHED.

NOTE: GRILLS DEFAULT SETTINGS WILL BE RESET WHEN UNPLUGGED.

°F	SILVERBAC®	GRILLA®	CHIMP®
DEFAULT:	-12-	-15-	-9-
-0°F	+20	+22	+16
0-45°F	16-20	19-21	13-16
46-75°F	12-16	15-18	9-12
75°F	8-12	10-14	6-8
+100°F	4-8	6-9	4-6

MODE 2 MORE SWING. MORE SMOKE.

- SCHEDULE BASED FEED CONTROL BASED ON INTERNAL GRILL TEMPERATURE.

MAINTENANCE AND CARE

Here are some maintenance and cleaning tips to help keep your Chimp running and operating smoothly. It may be helpful to refer to the “Parts Diagram” in this Operation Manual to locate the parts on your grill discussed below. Your Chimp can run efficiently for extended periods of time at different heat output levels, as long as the wood pellet supply is uninterrupted and timely cleaning and maintenance is performed.

- Always make sure your Chimp is off and cold before performing any maintenance or cleaning.
- Use a wire brush to clean your cooking grates after each use.
- Cover your drip tray with aluminum foil, and then change the foil frequently. This is the simplest way to maintain your drip pan. Ensure foil is wrapped tightly around the grease tray.
- If you have used a low-and-slow method that has caused the accumulation of grease on the aluminum foil, be sure to change it before cooking at high temperatures (or risk causing a grease fire).
- After every fifth bag of wood pellets, clean the ash from the interior of your grill, empty hopper and vacuum out debris (a shop vacuum cleaner is the perfect tool for this job).
- Clean inner temperature probe.
- Don't ever use wet pellets in your grill as they will swell and jam your Silverbac's auger.
- Once the grill is completely cooled, clean its outside with automotive wax, per the product's directions.
- Use a mild soap and water to clean the grill's powder-coated parts.
- Use a soft cloth and stainless steel polish to clean any of the grill's stainless steel parts.

For more Chimp Maintenance and Care information visit GrillaGrills.com

APPROVED FUEL: WOOD PELLETS

Chimp is only approved for burning barbecue wood pellets. Wood pellets are small in size, and generate about 8,200 BTUs per pound with very little ash and moisture content.

There are more than 125 active pellet mill operations in the United States and Canada, producing millions of pounds of pellets each year.

General specifications for barbecue pellets are:

- 100% hardwood
- 1" long or less in length
- ¼" diameter
- Less than 2% ash content
- Less than 2% fines
- Under 10% moisture content
- Approx. 8,200 BTUs per lb
- About 40 lbs per cubic ft. density

There are different flavors of wood pellets for your Silverbac.

Here is a table of wood pellet flavor suggestions and what they go best with:

	Beef	Chicken	Fish	Turkey	Pork	Lamb	Buffalo	Baking
Mesquite	x	x	x	x			x	
Hickory	x	x		x	x		x	
Apple		x		x	x			x
Alder	x	x	x	x	x	x	x	x

Mesquite Flavoring:

Mesquite, which means "the honey tree," gives a delicate, subtle, sweet flavor to grilled foods. It is especially good with poultry and seafood.

Hickory Flavoring:

Hickory intensifies the flavor of food with a robust, tangy taste that is better suited to red meat than to poultry or fish.

Apple or Fruitwoods Flavoring:

Apple or fruitwoods, many from orchards destroyed by fire or old age, are a big hit. Like its mesquite counterpart, the heaviest branches of the apple tree are heated to kill insects, then chipped, made into pellets and packaged for retail. Apple (or any fruitwood) adds a smoky, mild sweetness to everything you cook and is highly recommended for any baking.

Alder Flavoring:

Popular in the Northwest United States, alder produces a mild taste suited for salmon and other fish.

PARTS DIAGRAM

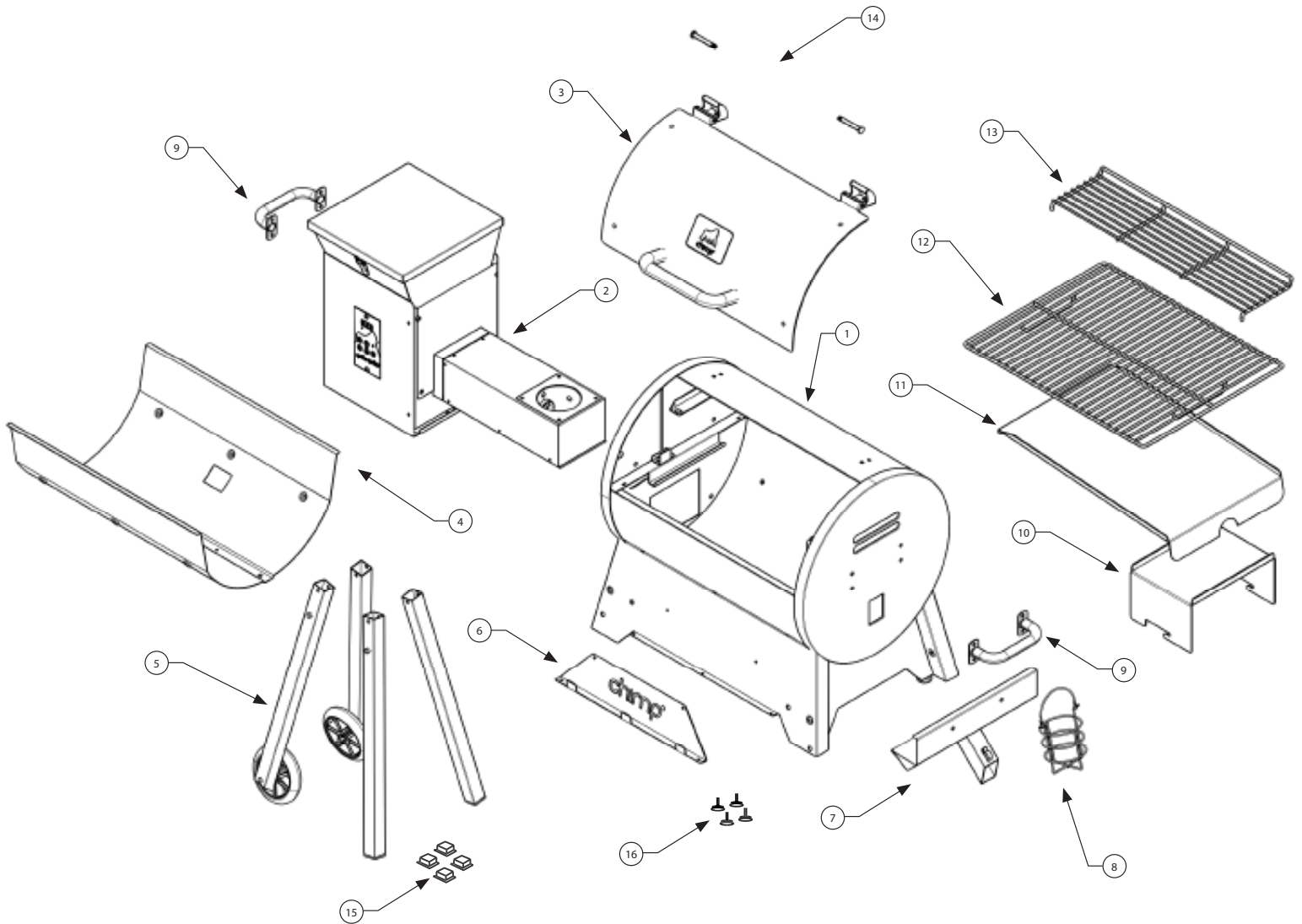

ITEM	DESCRIPTION
1	Grill Body
2	Hopper Assembly
3	Stainless Steel Lid
4	Thermal Baffle
5	Folding Legs
6	Multi Purpose Chimp Badge
7	Grease Catch
8	Grease Can Holder

ITEM	DESCRIPTION
9	Handles
10	Heat Shield
11	Grease Pan
12	Cooking Grate
13	Upper Grate
14	Lid Hardware
15	Leg Caps
16	Leveling Pads

INTERNAL PARTS DIAGRAM

Hopper / Burner Assembly:

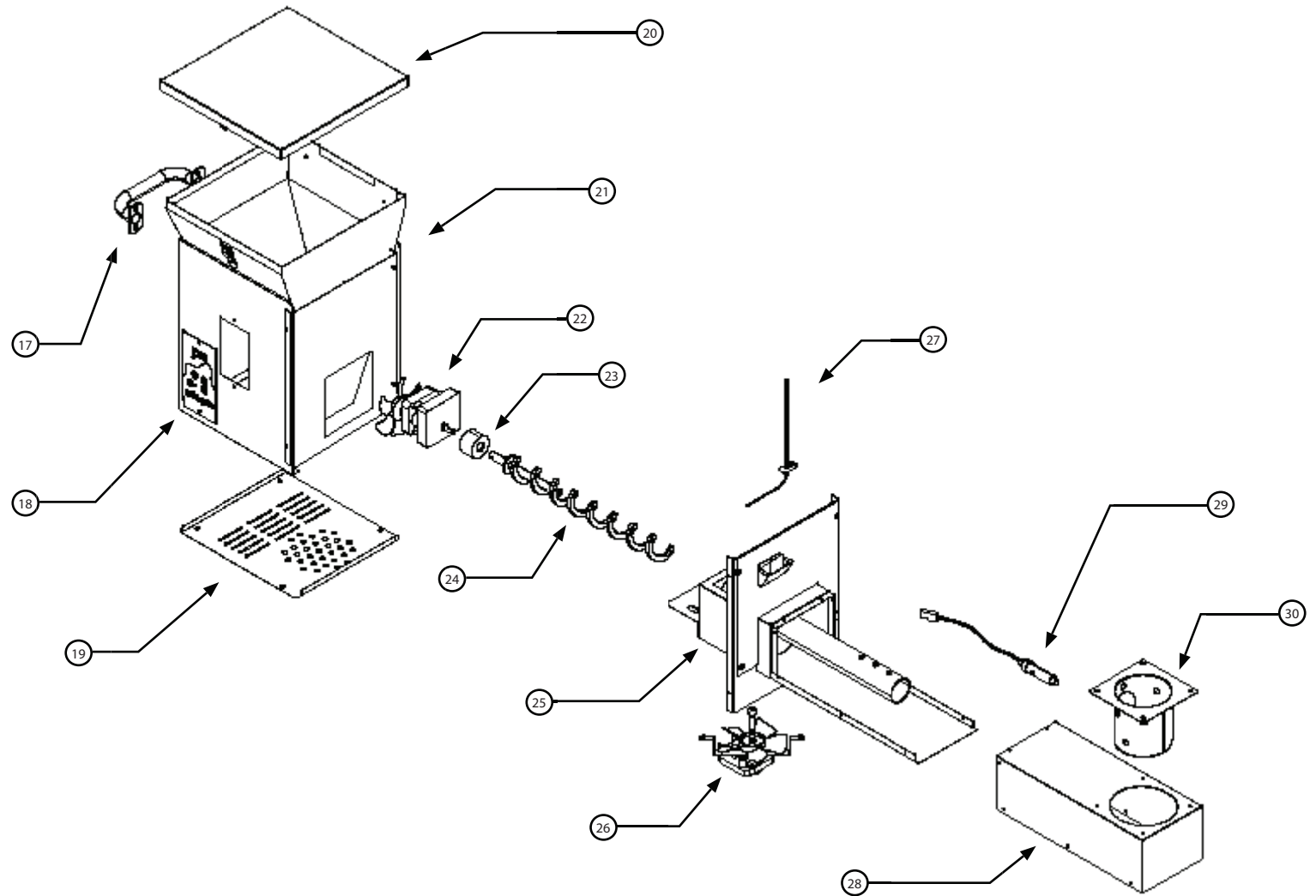

ITEM	DESCRIPTION
17	Hopper Handle
18	Control Board
19	Bottom Grate
20	Hopper Lid
21	Hopper Body
22	Auger Motor
23	Bushing

ITEM	DESCRIPTION
24	Auger Rod
25	Firebox Mount
26	Induction Fan
27	Grill Temp RTD
28	Firebox
29	Hot Rod
30	Burn Pot

TROUBLESHOOTING AND FAQ

For more Chimp Troubleshooting information visit GrillaGrills.com

The Chimp is very trouble-free in operation when properly maintained and quality fuel is used. If the Chimp fails to operate properly, use the following to troubleshoot.

Pellets are not being delivered into the Fire Pot – why?

1. Verify pellets are in the Hopper.
2. If this is the initial firing or the Chimp has run out of pellets, allow sufficient time for the pellets to travel from the Hopper to the Fire Pot (may take up to 5 minutes).
3. Once pellets begin to drop, turn the Chimp "Off" and then back "On" to re-start Ignition Mode.
4. Ensure the Auger is turning by removing the Lower Cooking Grate(8), Grease Pan (6) and Heat Baffle (5), and visually checking the Auger.
5. If Auger is not turning check fuse on back of controller and replace as necessary. If good, contact Grilla Grills or visit our website to view support videos.

 **CAUTION:** Never squirt gel on a burning or hot fire.

 **CAUTION:** During troubleshooting some components are hot. Allow unit adequate time to cool. Use gloves as needed.

Why won't my Chimp light?

1. Check outlet and verify Control Panel is powering up.
2. Make sure green LED light is on. This ensures outlet is good and fuse on the board is good. If not, check outlet and unplug grill and check fuse.
3. Turn Chimp "Off."
4. Remove Lower Cooking Grate (8), Grease Pan (6), and Heat Baffle (5).
5. Clean area of burned and unburned pellets.
6. Turn Chimp "On."
7. Verify Auger begins to turn and fuel is dropping into Fire Pot. If Auger is not turning see previous section.
8. If Auger is turning but pellets are not coming out ensure there are pellets in the Hopper if it ran empty or this is the first time for use, it will be necessary to prime the Auger. This will ensure pellets are at the end of the tube and will begin dropping once unit is turned on.
9. Igniter should begin to turn red within 1 to 2 minutes.

Where do I get parts for my Silverbac?

Be sure to be ready with your name, phone number, address, Chimp model number and serial number, along with the part identification number from the "Parts Diagram" on page 14.

LIMITED WARRANTY INFO

FAHRENHEIT TECHNOLOGIES, INC.

Fahrenheit Technologies, Inc. extends a limited warranty for its products as described on this page.

LIMITED LIFETIME WARRANTY

This limited warranty covers the Chimp Grill by Grilla Grills manufactured by Fahrenheit Technologies, Inc. The Chimp Grill has a 2-year limited warranty from the date of purchase by the original owner against defects in the material and workmanship when subjected to normal residential use. Limited warranty does not apply to paint, grill cover, or damage caused from corrosion.

Conditions of Limited Warranty

- During the term of the limited warranty, Grilla Grills' obligations shall be limited to replacement of covered, failed components. Grilla Grills will repair or replace parts returned to Grilla Grills, freight prepaid, if the part(s) are found by Grilla Grills to be defective upon examination. Grilla Grills shall not be liable for transportation charges, labor costs, or export duties.
- Grilla Grills takes every precaution to utilize materials that retard rust, including the use of high-temperature paint where advisable. Even with these safeguards, the protective coating can be compromised by various substances and conditions beyond Grilla Grills' control. High temperatures, excessive humidity, chlorine, industrial fumes, fertilizers, lawn pesticides, and salt are some of the substances that can affect paint and metal coatings. For these reasons, the limited warranties DO NOT COVER RUST OR OXIDATION.
- The warranty is based on residential use. Warranty coverage does not apply to products used in commercial applications.

Exceptions to the Limited Warranty

There is no written or implied performance warranty on Grilla Grills, as the manufacturer has no control over the installation, operations, cleaning, maintenance, or the type of fuel burned. This limited warranty will not apply, nor will Grilla Grills assume responsibility if your product has not been installed, operated, cleaned and maintained in strict accordance with the manufacturer's instructions. The warranty does not cover damage or breakage due to misuse, improper handling, or modifications. NEITHER THE MANUFACTURER NOR THE SUPPLIERS TO THE PURCHASER ACCEPTS RESPONSIBILITY, LEGAL OR OTHERWISE, FOR THE INCIDENTAL OR CONSEQUENTIAL DAMAGE TO THE PROPERTY OR PERSONS RESULTING FROM THE USE OF THIS PRODUCT. ANY WARRANTY IMPLIED BY LAW, INCLUDING BUT NOT LIMITED TO IMPLIED WARRANTIES OF MERCHANTABILITY OR FITNESS, SHALL BE LIMITED TO ONE (1) YEAR FROM THE DATE OF ORIGINAL PURCHASE. WHETHER A CLAIM IS MADE AGAINST THE MANUFACTURER BASED ON THE BREACH OF THIS WARRANTY OR ANY OTHER TYPE OF WARRANTY EXPRESSED OR IMPLIED BY LAW, MANUFACTURER SHALL IN NO EVENT BE LIABLE FOR ANY SPECIAL, INDIRECT, CONSEQUENTIAL OR OTHER DAMAGES OF ANY NATURE WHATSOEVER IN EXCESS OF THE ORIGINAL PURCHASE PRICE OF THIS PRODUCT. ALL WARRANTIES BY MANUFACTURER ARE SET FORTH HEREIN, AND NO CLAIM SHALL BE MADE AGAINST MANUFACTURER ON ANY ORAL WARRANTY OR REPRESENTATION. Some states do not allow the exclusion or limitation of incidental or consequential damages, or limitations of implied warranties, so the limitations or exclusions set forth in this limited warranty may not apply to you. This limited warranty gives you specific legal rights and you may have other rights, which vary from state to state.

LIMITED WARRANTY INFO (cont.)

The limited warranty for four (4) years is in lieu of all other warranties expressed or implied, at law or otherwise, and Grilla Grills does not authorize any person or representative to assume for Grilla Grills any obligation or liability in connection with the sale of this product. This means that no warranties, either expressed or implied, are extended to persons who purchase the product from anyone other than Grilla Grills or an authorized Grilla Grills Distributor.

Procedure for Warranty Service

Call Grilla Grills at 616-392-7410 for repair or replacement of your covered parts. Be prepared to furnish the following information:

- Purchaser's name, model and serial number of grill and date of purchase.
- An accurate description of the problem.





SAVE THIS MANUAL FOR FUTURE USE

VER 113018