



Certified to UL Subject 2728A
Certified to ULC/ORD-C2728
Pellet Fuel Burning Cooking Appliances

GR-500-CW

**OPERATION
MANUAL**

GRILLA® WOOD PELLET GRILL

SAVE THIS MANUAL FOR FUTURE USE

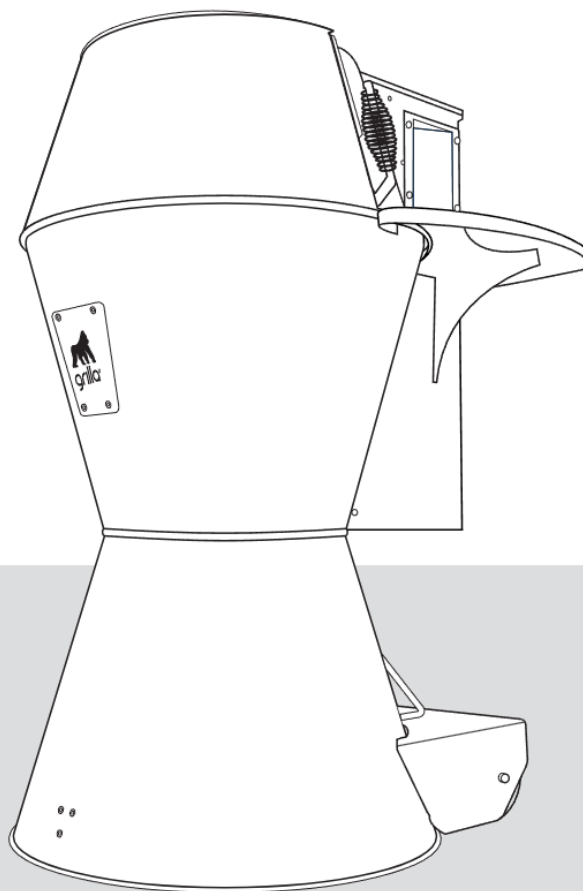

A MAJOR CAUSE OF FIRES IS FAILURE TO MAINTAIN REQUIRED CLEARANCES (AIR SPACES) TO COMBUSTIBLE MATERIALS. IT IS OF UTMOST IMPORTANCE THAT THIS PRODUCT BE INSTALLED ONLY IN ACCORDANCE WITH THESE INSTRUCTIONS.

DO NOT USE ACCESSORIES NOT SPECIFIED FOR USE WITH THIS APPLIANCE.

SAFETY INFORMATION

Please read this entire manual before installation and use of the pellet fuel-burning appliance. Failure to follow these instructions could result in property damage, bodily injury or even death. Contact local building or fire officials about restrictions and installation inspection requirements in your area.

SAVE THESE INSTRUCTIONS.

UNPLUG GRILL WHEN NOT IN USE.

 **DANGER:** Read carefully prior to use.

- Only use grill outdoors in a well ventilated area. Do not use in a garage, building, breezeway, tent, any other enclosed area, or beneath overhead combustible construction.
- Do not use grill in any vehicle or in any storage or cargo area of any vehicle. This includes, but is not limited to, cars, trucks, station wagons, mini-vans, sport utility vehicles, recreational vehicles, and boats.
- Do not put grill cover or any flammable on, or in the storage area under the grill while it is in use or is hot.
- Should a grease fire occur, turn off the grill and leave lid closed until fire is out.

 **WARNING:** Follow these guidelines to prevent this colorless, odorless gas from poisoning you, your family or others:

- Know the symptoms of carbon monoxide poisoning: headache, dizziness, weakness, nausea, vomiting, sleepiness, and confusion. Carbon monoxide reduces the blood's ability to carry oxygen. Low blood oxygen levels can result in loss of consciousness and death.
- See a doctor if you or others develop cold or flu-like symptoms while cooking or in the vicinity of this appliance. Carbon monoxide poisoning, which can easily be mistaken for cold or flu, is often detected too late.
- Alcohol consumption and drug use increase the effects of carbon monoxide poisoning.
- Carbon monoxide is especially toxic to mother and child during pregnancy, infants, the elderly, smokers, and people with blood or circulatory system problems, such as anemia, or heart disease.
- Only use your Grilla Grill outside on a noncombustible floor and away from combustible materials.
- Never use gasoline, gasoline-type lantern fuel, kerosene, charcoal lighter fluid, or similar liquids to start or 'freshen up' a fire in this appliance. Keep all such liquids well away from the appliance when in use.

 **WARNING:** Warning on Installation Clearance:

- Maintain a MINIMUM distance of 36 inches (91.4 cm) from the grill to combustible construction at the rear, side and top.
- A minimum of 40 inches (102 cm) is required when operating this grill under overhead combustibles.

 **WARNING:** Electrical shock can kill or result in serious injury. When using electrical appliances, basic safety precautions should always be followed to reduce the risk of fire, electric shock and injury to persons, including the following:

- Do not operate grill in the rain. Shield electric digital Control Panel, keeping it dry and out of rain at all times.
- To prevent grill from being splashed on or falling into water, do not use grill within 10 feet of pool, pond or other body of water.
- Do not use water or other liquid spray to clean grill without first shutting off unit and unplugging.
- Do not operate any appliance with a damaged cord or plug, after appliance malfunctions, or if it has been damaged in any manner.
- Never remove grounding plug, or use with a two-prong adapter.
- Outdoor extension cords should be marked with suffix letter W-A and with a tag stating "Suitable for Use with Outdoor Appliances."

 **WARNING:** Direct contact with the grill fire chamber during operation may cause severe burns to a person's skin. Never put water into the fire pot; it will jam the auger, and possibly short out the igniter.

-
- For safe assembly, use at least two people to unpack and assemble the grill.
 - Children should never use the Grilla®, as parts of the grill may be very hot. Keep children away while in use. Close supervision is necessary when any appliance is used near children.
 - The Grilla will become hot while in operation. Keep persons, clothing and furniture away from all hot surfaces.
 - Do not store or use combustible materials, gasoline or other flammable vapors and liquids in the vicinity of Grilla.
 - Never use flammable liquids such as gasoline, charcoal lighter fluid, kerosene, or similar liquids to start or re-light the fire in your grill. Keep all such liquids well away from the unit while it is in use. Burning improper fuel (i.e. charcoal) can result in carbon monoxide poisoning, which may lead to sickness or death.
 - Caution when moving the Grilla when the pellet hopper is full. The unit can become top-heavy and may tip over if moved.
 - Never move or transport the unit while it is hot and/or in operation. Make sure it is completely cold before being transported.
 - Position your grill on level ground. The grill should be kept as level as possible so that the grease flows into the trough and out into the can and also to ensure that the sensor reads evenly, as hot air displaced to one side or the other will cause irregular operation.
 - Follow Maintenance and Care instructions for safety of user and optimal performance.
 - Should a grease fire occur, turn the grill off, unplug it, and then close the lid until the fire extinguishes.
 - Do not touch hot surfaces. Use handles or knobs. Use heat-resistant mitts or gloves, pot holders or BBQ mittens when operating your Grilla.
 - Keep a fire extinguisher or water hose close by for safety.

OUR STORY

True story: Two men on a fishing trip, chowin' down at camp on a plate of ribs. One looks over at the grill (he's the industrial designer) and says, "Why do all those grills look the same, big ole barrel cut in half?" The other, a metalsmith by trade, answers, "Because we haven't built one." That's when the light bulb went off. Why not design and build a smoker grill that stands apart, literally, from the crowd. Hundreds of design hours later, the Grilla® was born.

Grilla takes advantage of convection smoking and grilling like no other, drawing cooking heat over the food for a moist, lip-smacking result. What's more, Grilla does it all with pellets, assuring even cooking and options for flavor profiles. Add a two-tier grill and digital controls, and you have one versatile Grilla.

Last but not least, all Grilla products are available direct to the hungry consumer. No fat in this business model; just pure value meal after delicious meal. Not bad for two fishing buddies.

Enjoy!

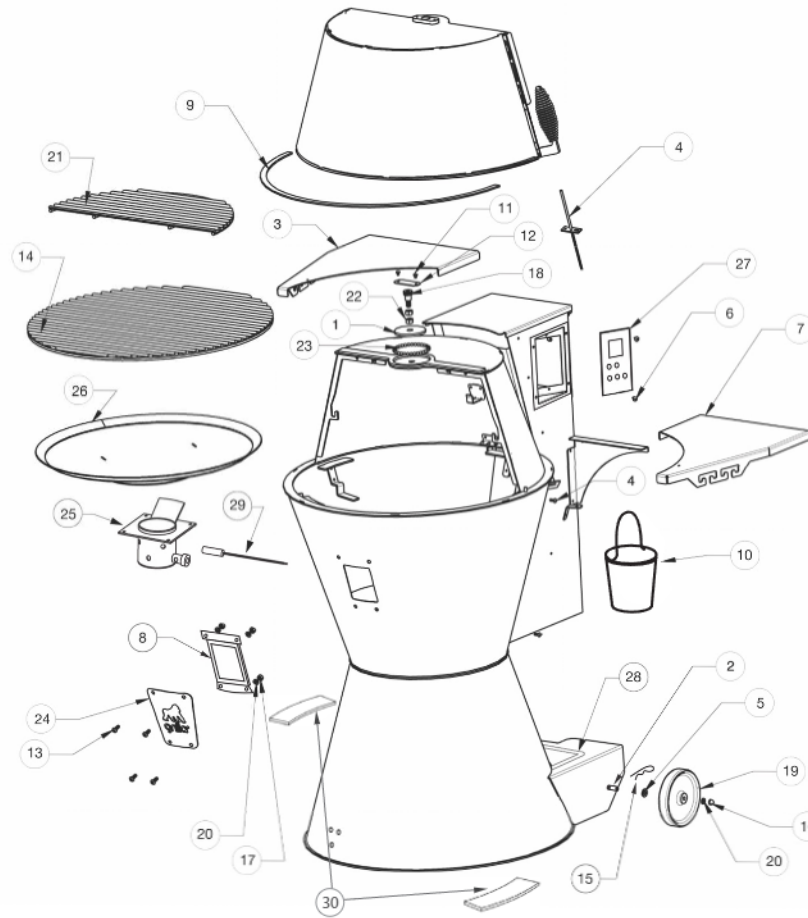

TABLE OF CONTENTS

SAFETY INFORMATION	2, 3
PARTS DIAGRAMS	6, 7
ASSEMBLY	8
WI-FI CONTROLLER OPERATION (SUPPLEMENT)	9
GETTING STARTED	9
OPERATING YOUR GRILLA®	9
MAINTENANCE AND CARE	10
ADDITIONAL INFORMATION	11
TROUBLESHOOTING AND FREQUENTLY ASKED QUESTIONS	12
APPROVED FUEL: WOOD PELLETS	13
LIMITED WARRANTY INFORMATION	14, 15

**FAILURE TO FOLLOW THIS OPERATIONAL MANUAL
IN ITS ENTIRETY WILL VOID ALL WARRANTIES**

PARTS DIAGRAM



ITEM	DESCRIPTION
1	Center Washer
2	Wheel Axle
3	Left Side Tray
4	RTD Probe
5	$\frac{5}{16}$ Washer
6	#8 x $\frac{1}{2}$ Square Drive
7	Right Side Tray
8	Glass with Frame
9	Lid Gasket
10	Grease Catch Bucket
11	M5 Black Zinc BHSS $\frac{1}{4}$ " long
12	Lid Pivot Cover
13	$\frac{1}{4}$ -20 x $\frac{1}{2}$ SS Button Head
14	Lower Cooking Grate
15	Axle Clevis Pin

ITEM	DESCRIPTION
16	Acorn Nut
17	M6 Hex Nut
18	M10 x $\frac{1}{2}$ " Shoulder Bolt
19	5" Die Caster Wheel
20	$\frac{1}{4}$ " Lock Washer
21	Upper Cooking Grate
22	M10 Nut
23	.250 Ball Bearing
24	Window Flange
25	Fire Pot
26	Flavor Disc
27	Control Panel
28	Foot Pedal
29	Igniter
30	Bottom solder

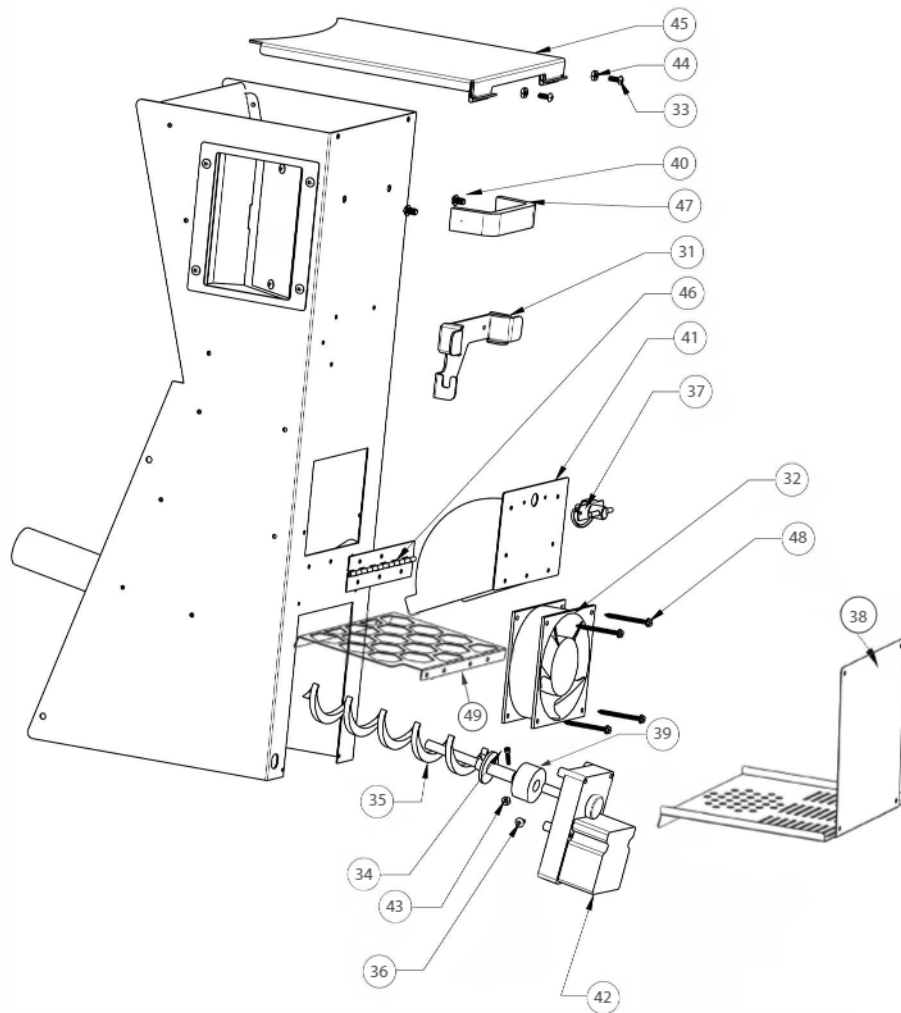

ITEM	DESCRIPTION
31	Cord Wrap
32	Grill Blower
33	#10-24 Black Zinc BHSS 1/2" Long
34	#6-32 x 3/4" Screw
35	Auger Screw Assembly
36	7mm Square Drive
37	Trap Door Latch
38	Maintenance Cover
39	Auger Bushing

ITEM	DESCRIPTION
40	M6 Hex Head
41	Trap Door
42	Grill Auger Motor
43	#10-24 Lock Nut
44	#6-32 Lock Nut
45	Hopper Lid
46	Trap Door Hinge
47	Hopper Handle
48	#8-32 x 2" Screw
49	Hopper stock

ASSEMBLY

Use the diagram below to assemble the Grilla side trays.

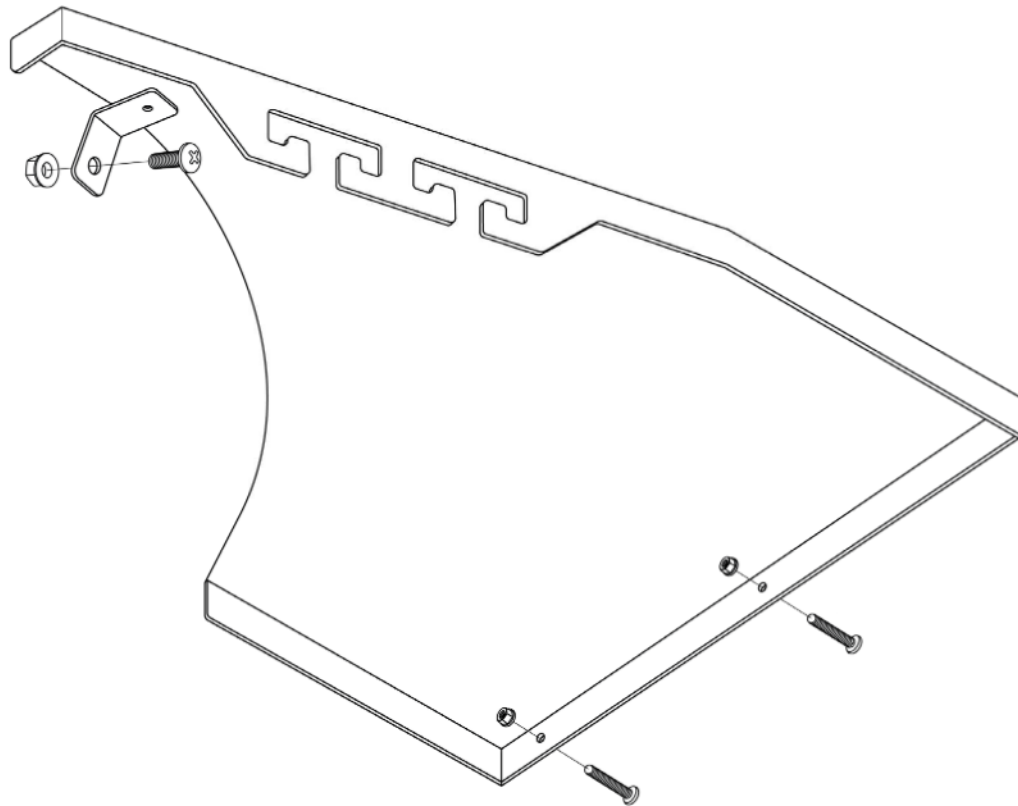

WI-FI CONTROLLER OPERATION

How to Operate Your Grilla®



REFERENCE THE ALPHA CONNECT GUIDE

ATTENTION: PLEASE READ BEFORE TURNING ON YOUR GRILL!

Getting Started:

1. Remove grill internal components exposing burn pot.
2. Fill Hopper with quality food grade pellets, plug-in electrical cord and turn on your grill.
3. Listen/look for pellets to drop into the burn pot, this should take anywhere from 2-4 minutes.
4. Turn your grill off, replace internal components, turn grill back on and set your temperature to 400°F for 45 minutes. Leave the lid open until the fire starts. When the time is complete, step down temperature to 225°F before turning off grill. *This process burns off any oils leftover from manufacturing.

Note: Leave your lid open until the flame is lit before closing your lid.

Operating your Grilla:

1. Ensure Hopper has pellets.
2. Plug-in Electrical Cord, turn grill on and set desired temperature.
3. Open lid and close once fire has started and temperature begins to rise.

Note: There is roughly a 15-20 minute stabilization period which must be completed before it will start making corrections to get to the desired setting. It is recommended you leave the lid shut during this period.

MAINTENANCE AND CARE



CAUTION: Periodic maintenance should only be done while the Grilla® is shut off and cold. Time frames are suggestions only; maintenance frequency depends on fuel and the amount of use. Make sure your Grilla is COMPLETELY COLD before performing any maintenance.

Auger Removal/Installation (Reference pg. 7)

1. Unplug Grilla.
2. Empty Hopper.
3. Remove Maintenance Cover (38).
4. Cut zip ties and Unplug Grill Auger Motor.
5. Remove single screw at the bottom of the Auger Screw Assembly (36).
6. Slide Auger Screw Assembly out.
7. Reverse steps for re-installation, ensuring Auger has the anti-rotation bracket and is rotated down at roughly the 6 o'clock position when installed. Wires need to be re-secured with zip ties or wire ties.

Fire Pot Removal/Installation (Reference pg. 6)

1. Unplug Grilla.
2. Remove Lower Cooking Grate (14), Grease Can Holder (10) and Flavor Disc (26).
3. Remove zip ties from Igniter wires.
4. Remove 4 screws.
5. Rotate Fire Pot 90° and lift up and out.
6. Loosen collar screw fastening Igniter.
7. Slide Igniter out.
8. Reverse steps to install and ensure the Igniter goes into the Fire Pot, exposing the Igniter into the Fire Pot roughly 1/4".

Igniter Removal/Installation

1. Complete "Fire Pot Removal/Installation" above. Note—remove zip tie for wire harness behind Maintenance Cover, Pull wires out to expose connectors and unplug.
2. Loosen collar screw.
3. Slide Igniter out.
4. Call Grilla for replacement part.
5. Reverse steps for re-installation.

Cleaning

Do not use oven cleaner, abrasive cleansers or abrasive cleaning pads on the powder coated Grilla surfaces. Use warm soapy water to cut the grease. Use Stainless Steel cleaner on everything Stainless except cooking grates.

Clean Hopper, Burn Pot, and Burn Chamber after every other bag of fuel, or as necessary. Clean RTD probe (inner temperature probe) with a damp or lightly soapy towel regularly.

Protecting Your Grilla

- Use a protective cover on your Grilla after each use. Make sure Grilla is COMPLETELY COOL before covering. A Grilla Cover is highly recommended!
- If the Grilla is stored outside, care should be taken to ensure that water does not get into the Hopper. Wood pellets, when wet, expand and will jam the auger.
- Use touch-up paint to repair any scratches.
- Grilla Covers and touch-up paint are available through GrillaGrills.com.
- You should thoroughly clean and inspect your Grilla on a regular basis. Recommended prior to a prolonged smoke.

Disposal Of Ashes

Ashes should be placed in a metal container with a tight fitting lid. The closed container of ashes should be placed on a noncombustible floor or on the ground, well away from all combustible materials, pending final disposal. If

the ashes are disposed of by burial in soil or otherwise locally dispersed, they should be retained in closed container until all cinders have thoroughly cooled.

For more Grilla Maintenance and Care information, visit GrillaGrills.com

ADDITIONAL INFORMATION

Manual Startup

When power button is quickly depressed and released.

Manual Startup for Wi-Fi Provisioning

When power button is depressed for 4 seconds and then released.

Shutdown Sequence

When power button is pressed for 2 seconds:

- **Auger** turns off.
 - **Fan** continues to run for 5 to 15 minutes.
 - **Control Panel** displays C5, C4, C3, C2, C1 (minutes) then goes blank.
When power button is pressed for 2 seconds and temperature is over 400° (High Temp Shutdown)
 - **Control Panel** displays C15, C14, C13... down to C1 (minutes) then goes blank.
-

ErL (low temp) Code

- Grill temp was below 150°F for more than 10 minutes.
-

ErH (high temp) Code

- Grill temp reached 615°F.
-

FHi (food high) Code

- Food probe is above 225°F. Removing probe from socket returns board to normal read out and clears flashing code. (Tip - Do not submerge, leave on the grill without being inserted into food or bend the wires to avoid damage.)
-

Ignition Sequence

When power button is pressed:

- **Igniter** turns on and runs for 4 minutes. At 4 minutes, if temp is above 150°F, it turns off. If temp is below 150°F after 4 minutes, it stays on for 4 more minutes (8 total) then turns off.
- **Auger** turns on at 100% during the ignition stage then goes to normal temperature control operation.
- **Fan** turns continuously.
- **Control Panel** displays current temperature. If below 110°F, the display will be flashing until above 110°F. It has 10 minutes (ERL requirement) to get above this or it initiates ERL code.



WARNING: Never move or transport the unit while it is hot and/or in operation.

Follow these operating instructions exactly as stated to ensure safe and reliable operation. Carefully read this manual.

TROUBLESHOOTING AND FAQ

For more Grilla Troubleshooting information visit GrillaGrills.com

The Grilla® is very trouble-free in operation when properly maintained and quality fuel is used. If the Grilla fails to operate properly, use the following to troubleshoot.

How do I remove the auger if it jams?

1. Unplug Grilla.
2. Empty hopper and clean out auger with vacuum as necessary to remove any loose debris.
3. If auger still will not turn, see "Auger Removal" section on page 10 under "Maintenance and Care."
4. Once auger has been removed, clean tube and auger and re-install.
5. Plug Grilla in and turn "On."
6. If the auger still won't turn, motor may need replacing. Contact Grilla.

Pellets are not being delivered into the Fire Pot – why?

1. Verify pellets are in the hopper.
2. If this is the initial firing, or the Grilla has run out of pellets, allow sufficient time for the pellets to travel from the hopper to the firepot (may take up to four minutes).
3. Once pellets begin to drop, turn the Grilla "Off" and then back "On" to re-start ignition mode (see step 3 and 4 in "GETTING STARTED" section on page 9).
4. Ensure the auger is turning by removing the Lower cooking grate, grease catch can holder and flavor disc and visually checking the auger.
5. If auger is not turning, see "How do I remove the auger if it jams?" section above.

 **CAUTION:** Never squirt gel on a burning or hot fire.

 **CAUTION:** During troubleshooting some components are hot. Allow unit adequate time to cool. Use gloves as needed.

Why won't my Grilla light?

Three elements are needed for a fire in your Grilla. You need fuel, heat and air. Here are the things to look for: Pellets? Auger turning to deliver the pellets? Fan blowing air to the pot? Igniter heating up at start up? Power?

1. Check outlet and verify control panel is powering up.
2. If outlet is good and LED screen is not coming on, unplug, and check fuse on back of control panel.
3. Remove lower cooking grate (14), grease catch can holder (10) and flavor disc (26).
4. Clean area of burned and unburned pellets.
5. Plug Grilla in and turn "On."
6. Verify auger is turning and fuel is dropping into fire pot. If auger is not turning, see "How do I remove the auger if it jams?" section to the left.
7. If auger is turning but pellets are not coming out, ensure there are pellets in the hopper. If it ran empty or this is the first time for use, it will be necessary to prime the auger (see "GETTING STARTED" section page 6 for directions). This will ensure pellets are at the end of the tube and will begin dropping once unit is turned on.
8. Igniter should begin to turn red within 1 to 2 minutes. If not, see IGNITER REMOVAL/ INSTALLATION section on page 10.

Where do I get parts for my Grilla?

Be sure to be ready with your name, phone number, address, Grilla model number and serial number, along with the part identification number from the "Parts Diagram" on page 6 & 7. Then contact Grilla online or by phone.

APPROVED FUEL: WOOD PELLETS

Grilla® is only approved for burning barbecue wood pellets. Wood pellets are small in size and generate about 8,200 BTUs per pound with very little ash and moisture content.

There are more than 125 active pellet mill operations in the United States and Canada, producing millions of pounds of pellets each year. We have our own Grilla brand that we recommend. These all ignite easily and create great heat and flavor. Some brands infuse Charcoal or Alder wood which will burn hotter & faster and may cause issues.

General specifications for barbecue pellets are:

- 100% hardwood
- 1" long or less in length
- ¼" diameter or less
- Less than 2% ash content
- Less than 2% fines
- Under 10% moisture content
- Approx. 8,200 BTU's per lb.
- About 40 lbs per cubic ft. density

FIND YOUR FLAVOR



					
	BEEF	PORK	POULTRY	SEAFOOD	VEGGIES
MESQUITE					
HICKORY					
APPLE					
CHERRY					
PECAN					
COMPETITION BLEND					

⚠ CAUTION: Always store wood pellets in a dry location, away from sources of heat and other fuel containers.

- For best flavor, use Grilla Competition-Grade wood pellet fuel.
- Do not use pellet fuel labeled as having additives.

LIMITED WARRANTY INFO

Grilla® warrants that its products are free from defects in materials and workmanship for the applicable warranty period, subject to the conditions below.

LIMITED WARRANTY

Under the Limited Warranty, we will repair or replace your Grilla product at no charge to you if it is found to be defective during the applicable warranty period. The Limited Warranty does not cover products or component parts which have been lost or stolen; or subject to misuse, intentional damage, modifications, or repairs made or attempted by anyone other than a qualified technician following Grilla procedures; or damage that is cosmetic only and does not affect the product's operation or performance (as determined by us at our sole discretion).

WARRANTY PERIOD

Four (4) Year Warranty

Conditions of Limited Warranty

- During the term of the limited warranty, Grilla's obligations shall be limited to replacement of covered, failed components. Grilla will repair or replace parts returned to Grilla, freight prepaid, if the part(s) are found by Grilla to be defective upon examination. Grilla shall not be liable for transportation charges, labor costs, or export duties.
- Grilla takes every precaution to utilize materials that retard rust, including the use of high-temperature paint where advisable. Even with these safeguards, the protective coating can be compromised by various substances and conditions beyond Grilla's control. High temperatures, excessive humidity, chlorine, industrial fumes, fertilizers, lawn pesticides, and salt are some of the substances that can affect paint and metal coatings. For these reasons, the limited warranties DO NOT COVER RUST OR OXIDATION.
- The warranty is based on residential use. Warranty coverage does not apply to products used in commercial applications.

Exceptions to the Limited Warranty

There is no written or implied performance warranty on Grilla, as the manufacturer has no control over the installation, operations, cleaning, maintenance, or the type of fuel burned. This limited warranty will not apply, nor will Grilla assume responsibility if your product has not been installed, operated, cleaned and maintained in strict accordance with the manufacturer's instructions. The warranty does not cover damage or breakage due to misuse, improper handling, or modifications. NEITHER THE MANUFACTURER NOR THE SUPPLIERS TO THE PURCHASER ACCEPTS RESPONSIBILITY, LEGAL OR OTHERWISE, FOR THE INCIDENTAL OR CONSEQUENTIAL DAMAGE TO THE PROPERTY OR PERSONS RESULTING FROM THE USE OF THIS PRODUCT. ANY WARRANTY IMPLIED BY LAW, INCLUDING BUT NOT LIMITED TO IMPLIED WARRANTIES OF MERCHANTABILITY OR FITNESS, SHALL BE LIMITED TO ONE (1) YEAR FROM THE DATE OF ORIGINAL PURCHASE. WHETHER A CLAIM IS MADE AGAINST THE MANUFACTURER BASED ON THE BREACH OF THIS WARRANTY OR ANY OTHER TYPE OF WARRANTY EXPRESSED OR IMPLIED BY LAW, MANUFACTURER SHALL IN NO EVENT BE LIABLE FOR ANY SPECIAL, INDIRECT, CONSEQUENTIAL OR OTHER DAMAGES OF ANY NATURE WHATSOEVER IN EXCESS OF THE ORIGINAL PURCHASE PRICE OF THIS PRODUCT. ALL WARRANTIES BY MANUFACTURER ARE SET FORTH HEREIN, AND NO CLAIM SHALL BE MADE AGAINST MANUFACTURER ON ANY ORAL WARRANTY OR REPRESENTATION. Some states do not allow the exclusion or limitation of incidental or consequential damages, or limitations of implied warranties, so the limitations or exclusions set forth in this limited warranty may not apply to you. This limited warranty gives you specific legal rights and you may have other rights, which vary from state to state.

LIMITED WARRANTY INFO (cont.)

The limited warranty for four (4) years is in lieu of all other warranties expressed or implied, at law or otherwise. Grilla does not authorize any person or representative to assume for Grilla any obligation or liability in connection with the sale of this product. This means that no warranties, either expressed or implied, are extended to persons who purchase the product from anyone other than Grilla or an authorized Grilla Distributor.

Procedure for Warranty Service

Call Grilla at (616) 392-7410 for repair or replacement of your covered parts. Be prepared to furnish the following information:

- Purchaser's name, model and serial number of grill and date of purchase.
- An accurate description of the problem.



1800 N. Route Z, Suite A, Columbia, MO 65202
www.aob.com

©2023 AOB PRODUCTS COMPANY



SAVE THIS MANUAL FOR FUTURE USE

Manual #4000217 | Ver. 004