

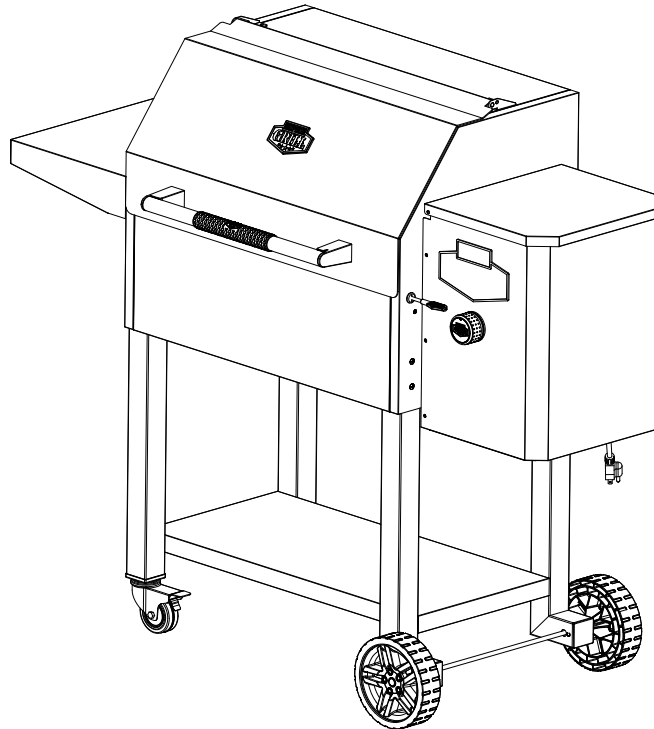

Model No.: XG1136224169002

Owner's Manual
Expert Grill Commodore



**A MAJOR CAUSE OF FIRES IS FAILURE TO MAINTAIN
REQUIRED CLEARANCES (AIR SPACES) TO
COMBUSTIBLE MATERIALS. IT IS OF UTMOST
IMPORTANCE THAT THIS PRODUCT BE INSTALLED ONLY
IN ACCORDANCE WITH THESE INSTRUCTIONS.**

READ ALL INSTRUCTIONS BEFORE INSTALLING AND USING THE APPLIANCE

Failure to follow these instructions could result in property damage, bodily injury or even death.

Contact local building or fire officials about restrictions and installation inspection requirements in your area.

SAVE THESE INSTRUCTIONS

For Outdoor Use Only

**If you have any questions or problems, you can contact our customer service at 855-256-2160 or
expertgrill@grillservices.net from 8 AM - 4:30 PM Eastern Time, Monday to Friday**

Table of Contents

WARNING.....	- 1 -
Parts Diagram.....	- 3 -
Assembly Steps.....	- 5 -
Use of the Pellet Grill.....	- 15 -
Placement of the Device.....	- 15 -
Outdoor Cooking Pellets.....	- 15 -
Confirmation before Powering on.....	- 15 -
Button Function Description.....	- 16 -
Ignition Instructions.....	- 18 -
Cooking Instructions.....	- 19 -
Ashes Clean-out.....	- 20 -
Pellet Hopper Clean-out.....	- 21 -
Cleaning and Maintenance.....	- 21 -
Connection of the App.....	- 22 -
Troubleshooting.....	- 24 -
Warranty.....	- 28 -
Customer Service.....	- 28 -

WARNING

※When this product is not properly installed or assembled, a fire may result. To reduce the risk of fire, follow the installation instructions.

※Read this entire manual before you install the product. Failure to follow instructions may result in property damage, bodily injury, or even death.

※This appliance is not intended for indoor residential use.

※Do not install under a combustible ceiling or overhang.

※Never use gasoline, gasoline-type lantern fuel, kerosene, charcoal lighter fluid, or similar liquids to start or ‘freshen up’ a fire in this appliance. Keep all such liquids well away from the appliance when in use.

※Disposal of ashes – Ashes should be placed in a metal container with a tight-fitting hood. The closed container of ashes should be placed on a non-combustible floor or on the ground, well away from all combustible materials, pending final disposal. When the ashes are disposed by burial in soil or otherwise locally dispersed, they should be retained in the closed container until all cinders have thoroughly cooled.

※Use Only Wood Pellet Fuel Specified By EXPERT GRILL. Do Not Use Pellet Fuel Labeled As Having Additives.

※Remove pots and pans while the operating appliance is unattended, to reduce the risk of fire.

※Do not use accessories not specified for use with this appliance.

※Use grounding receptacle that complies with the local safety regulations. If the receptacle needs to be reinstalled, please follow local electrical specification.

※Dangerous voltage will cause shock, burn or death. In case of device failure, please follow the prompt of the instruction or contact customer service. Unplug from power before maintenance.

※There will be high temperature in local positions in the use of the device, please do not move the device casually and take care of the old and children and beware of burn.

※Follow these guidelines to prevent this colorless, odorless gas from poisoning you, your family or others.

- Know the symptoms of carbon monoxide poisoning: headache, dizziness, weakness, nausea, vomiting, sleepiness, and confusion. Carbon monoxide reduces the blood’s ability to carry oxygen. Low blood oxygen levels can result in loss of consciousness and death.
- See a doctor if you or others develop cold or flu-like symptoms while cooking or in the vicinity of this appliance. Carbon monoxide poisoning, which can easily be mistaken for a cold or flu, is often detected too late.
- Alcohol consumption and drug use increase the effects of carbon monoxide poisoning.
- Carbon monoxide is especially toxic to mother and child during pregnancy, infants, the elderly, smokers, and people with blood or circulatory system problems, such as anemia, or heart disease.

※Creosote – — Formation and need for removal. When wood pellets are burned slowly, they produce tar and other organic vapors that combine with expelled moisture to form creosote. The creosote vapors condense in a relatively cool oven flue and exhaust hood of a slow burning fire. As a result, creosote residue accumulates on the flue lining and exhaust hood. When ignited, this creosote makes an extremely hot fire.

※The grease duct should be inspected at least twice a year to determine when grease and/ or creosote buildup has occurred.

- ※ When grease or creosote has accumulated , it should be removed to reduce risk of fire.
- ※ Do not burn for a long time to prevent the product from overheating.
- ※ Remove the POP labels before using the grill.

 **WARNING**









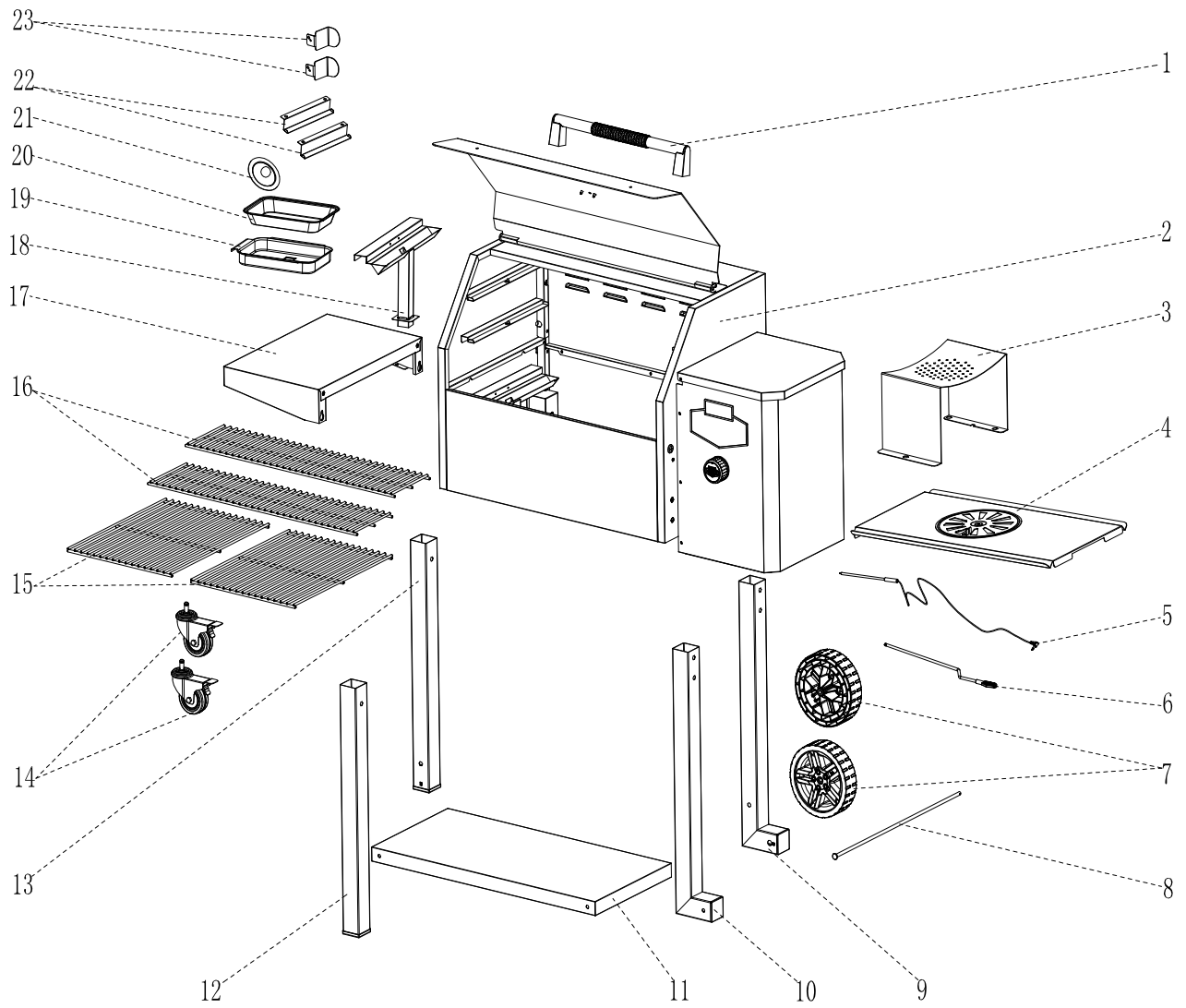

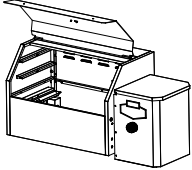
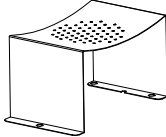
When installed, must be electrically grounded in accordance with local codes or, in the absence of local codes, with the National Electrical Code, ANSI/NFPA 70, or the Canadian Electrical Code, Part I, CSA C22.1.

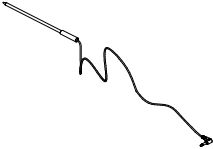
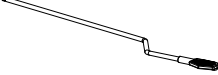
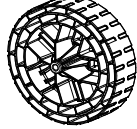
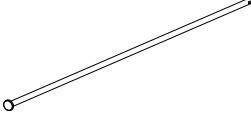
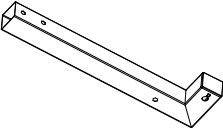
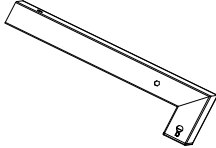
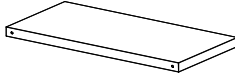
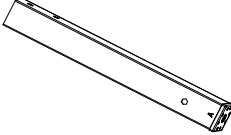
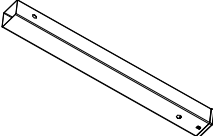
Keep any electrical supply cord and the fuel supply hose away from any heated surfaces.

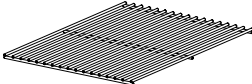
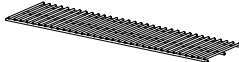
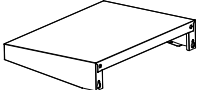
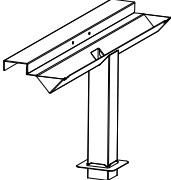



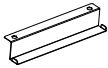

- a) To protect against electric shock, do not immerse cord or plugs in water or other liquid.
- b) Unplug from the outlet when not in use and before cleaning. Allow to cool before putting on or taking off parts.
- c) Do not operate any outdoor cooking gas appliance with a damaged cord, plug, or after the appliance malfunctions, or has been damaged in any manner. Contact the customer service for repair.
- d) Do not let the cord hang over the edge of a table or touch hot surfaces.
- e) Do not use an outdoor cooking gas appliance for purposes other than intended.
- f) When connecting, first connect plug to the outdoor cooking gas appliance then plug appliance into the outlet.
- g) Use only a Ground Fault Interrupter (GFI) protected circuit with this outdoor cooking gas appliance.
- h) Never remove the grounding plug or use with an adapter of 2-prong.
- i) Use only extension cords with a 3-prong grounding plug, rated for the power of the equipment, and approved for outdoor use with a W-A marking.

Parts Diagram



1	Hood Handle	2	Firebox Body	3	Flame Tamer	4	Grease Drain Pan
 x1		 x1		 x1		 x1	
5	Meat Probe	6	Searing Station Pull Handle	7	Wheel	8	Wheel Axle
 x1		 x1		 x2		 x1	
9	Right Rear Leg	10	Right Front Leg	11	Bottom Shelf	12	Left Front Leg
 x1		 x1		 x1		 x1	
13	Left Rear Leg	14	Locking Caster	15	Cooking Grid	16	Warming Rack
 x1		 x2		 x2		 x2	
17	Side Shelf	18	Grease Guide Assembly	19	Grease Tray	20	Foil Liner
 x1		 x1		 x1		 x1	
21	Ash Clean-out Cover	22	Grease Tray Bracket	23	Power Cord Bracket		
 x1		 x2		 x2			

Hardware

A	B	C	D	E	F
 X6	 X20	 X12	 X1	 X2	 X2

Tools required for assembly

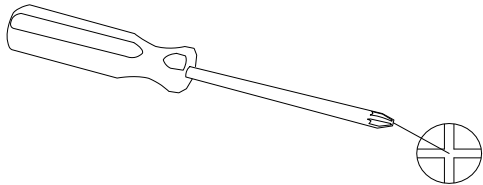

Philips Head Screwdriver (not included).

Assembly Steps

STEP 1

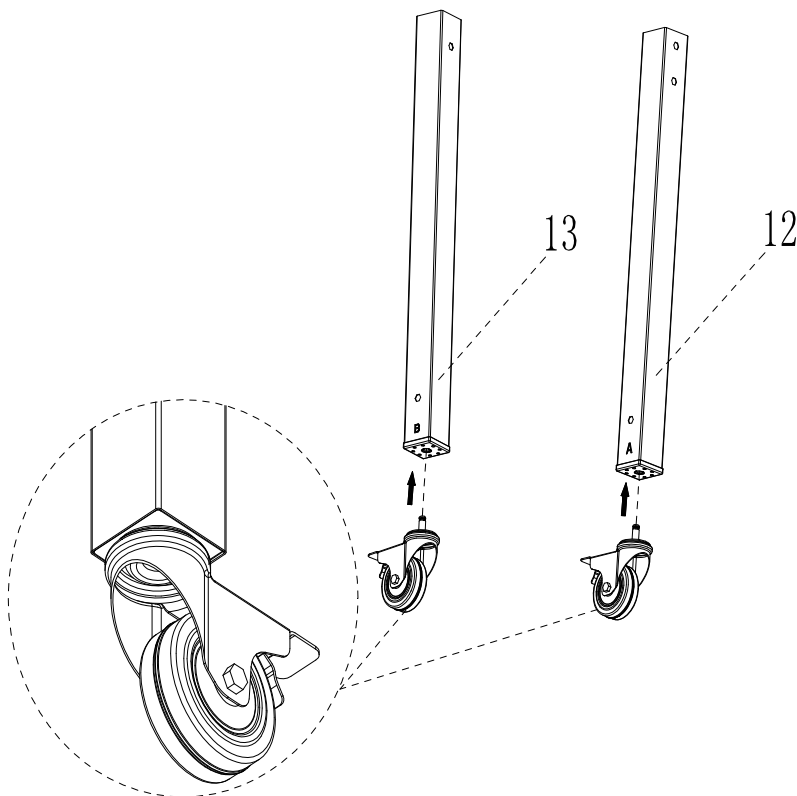

Parts Required:

- Locking Caster (Part #14) x2
- Left Front Leg (Part #12) x1
- Left Rear Leg (Part #13) x1

Installation:

- Insert Locking Caster (Part #14) stem into bottom of Left Front Leg (Part #12). Press into hole until click is felt. Ensure caster is secure and cannot easily back out.
- Repeat for Left Rear Leg (Part #13)

STEP 2

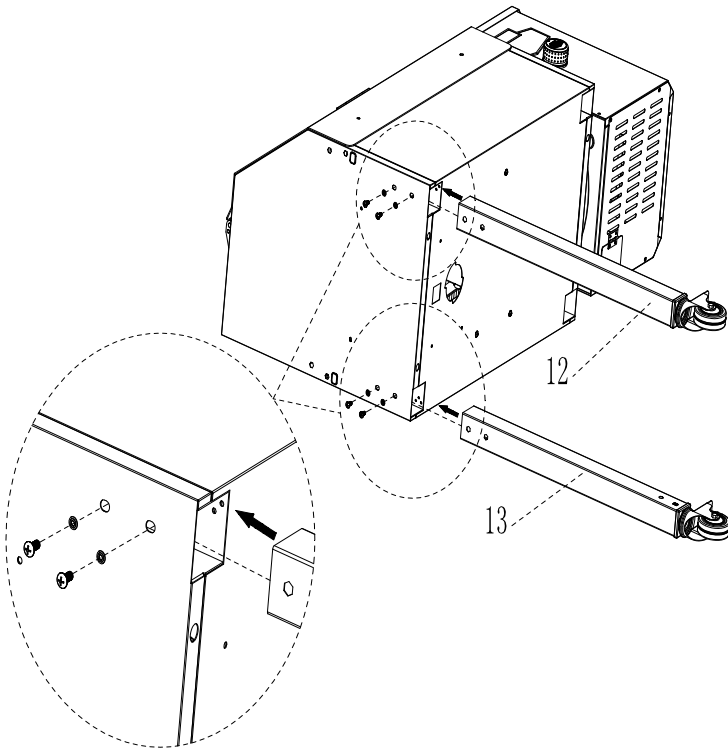

Parts / Hardware Required:

- Left Front Leg (Part #12) x1
- Left Rear Leg (Part #13) x1
- Firebox Body (Part #2) x1

-  (Hardware B) x4

-  (Hardware C) x4

Installation:

- Insert the Left Front Leg (Part #12) and Left Rear Leg (Part #13) into Firebox Body (Part #2)
- Use 4 screws (Hardware B) and 4 washers (Hardware C).

Note: The washers concave side down when install.

STEP 3

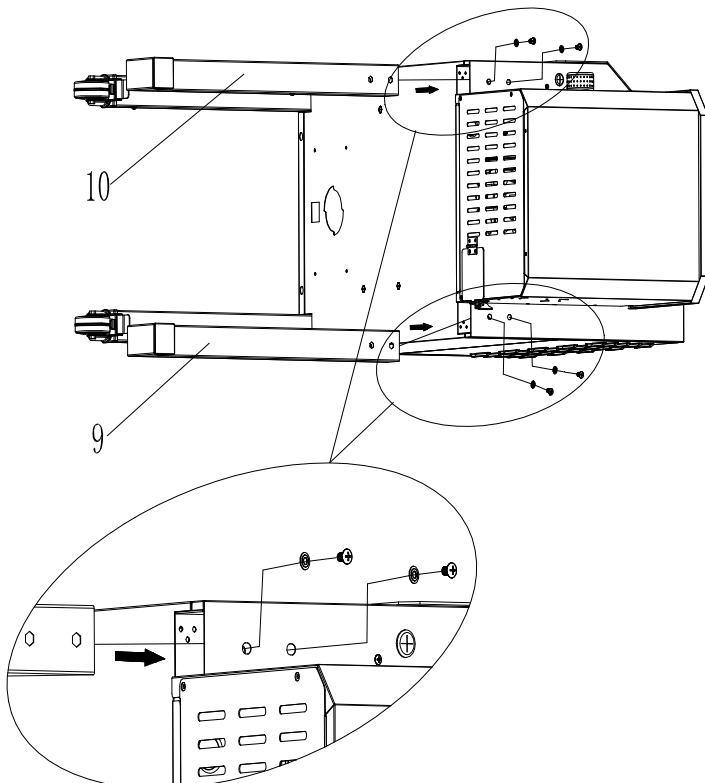

Parts / Hardware Required:

- Right Rear Leg (Part #9) x1
- Right Front Leg (Part #10) x1
- Firebox Body (Part #2) x1

-  (Hardware B) x4

-  (Hardware C) x4

Installation:

- Insert the Right Rear Leg (Part #9) and Right Front Leg (Part #10) into Firebox Body (Part #2)
- Use 4 screws (Hardware B) and 4 washers (Hardware C).

Note: The washers concave side down when install.

STEP 4

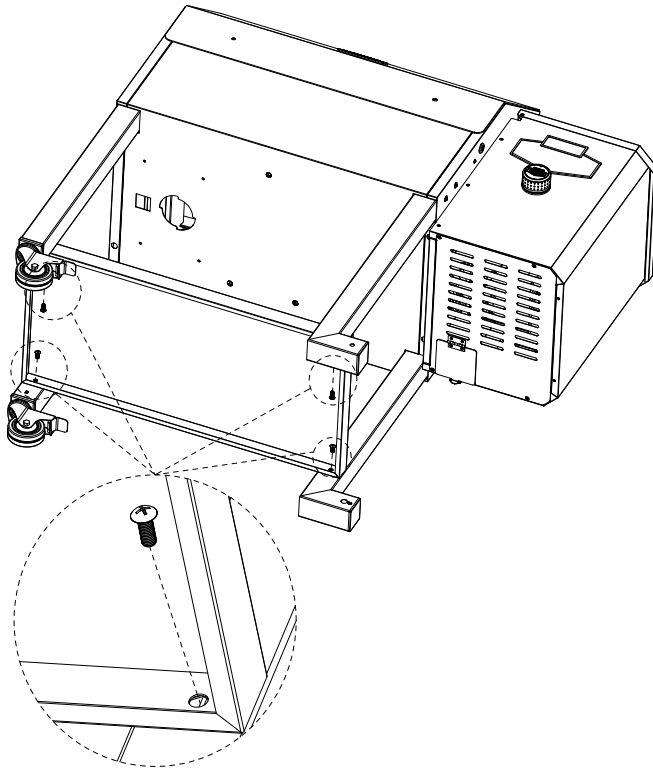

Parts / Hardware Required:

- Bottom Shelf (Part #11) x1
-  (Hardware B) x4

Installation:

- Attach Bottom Shelf (Part #11) to legs using 4 screws (Hardware B) from underside of shelf.

STEP 5

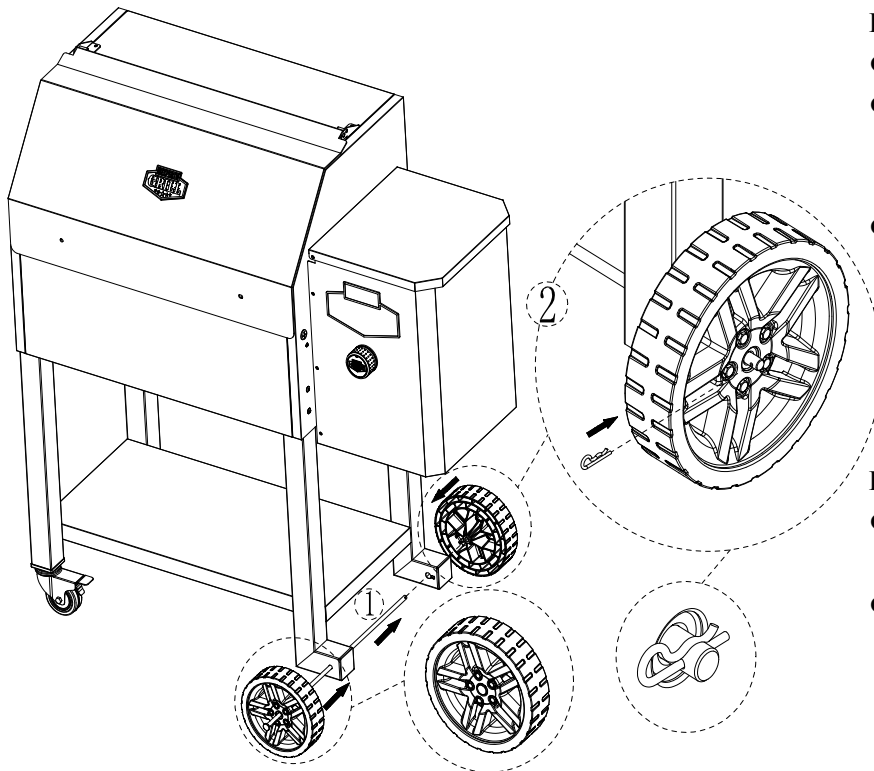

Parts / Hardware Required:

- Wheel Axle (Part #8) x1
- Wheel (Part #7) x2
-  (Hardware D) x1



Installation:

- Upright grill with help from an additional person.
- Insert Wheel Axle (Part #8) through Wheel (Part #7) and Insert Axle through Wheel and Leg (Part #10), Leg (Part #9)
- Place R Pin (Hardware D) onto Wheel Axle.

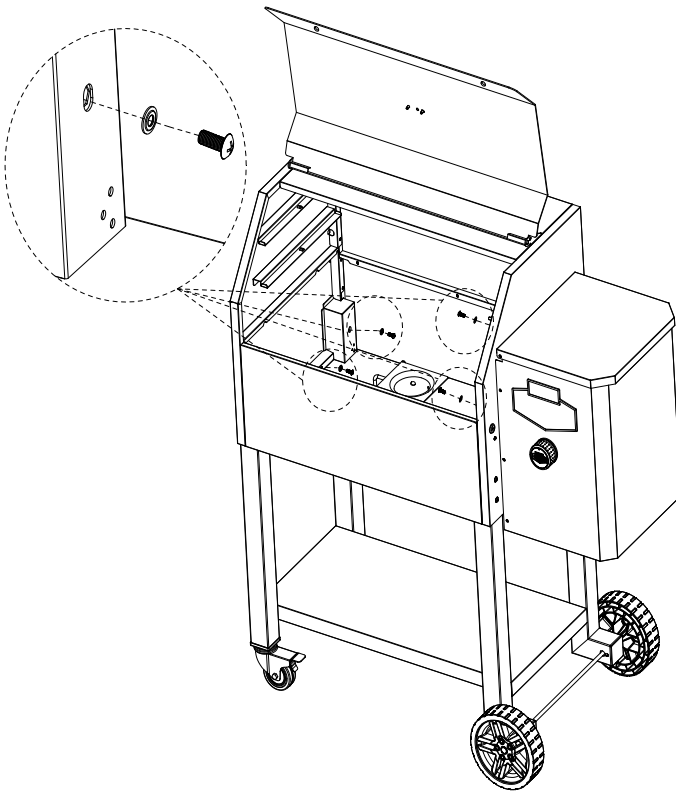
STEP 6



Hardware Required:

-  (Hardware B) x4
-  (Hardware C) x4

Installation:

- Open the Hood.
- Use 4 screws (Hardware B) and 4 washers (Hardware C) as shown.

Note: The washers concave side down when install.

STEP 7

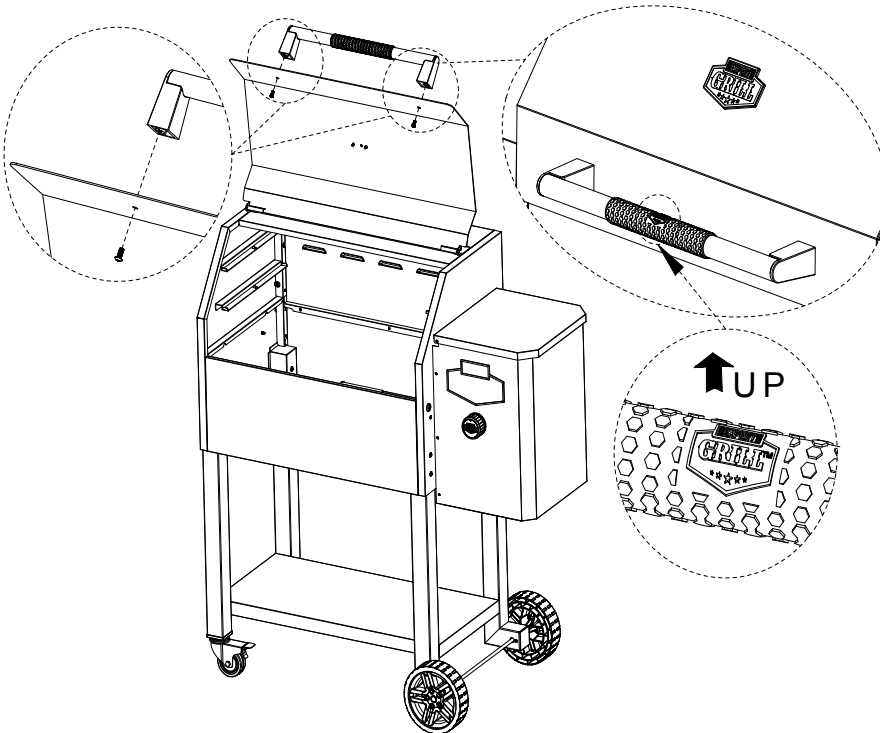

Parts / Hardware Required:

- Hood Handle (Part #1) x1
-  (Hardware E) x2

Installation:

- Mount Hood Handle (Part #1)
- Use 2 screws (Hardware E)

STEP 8

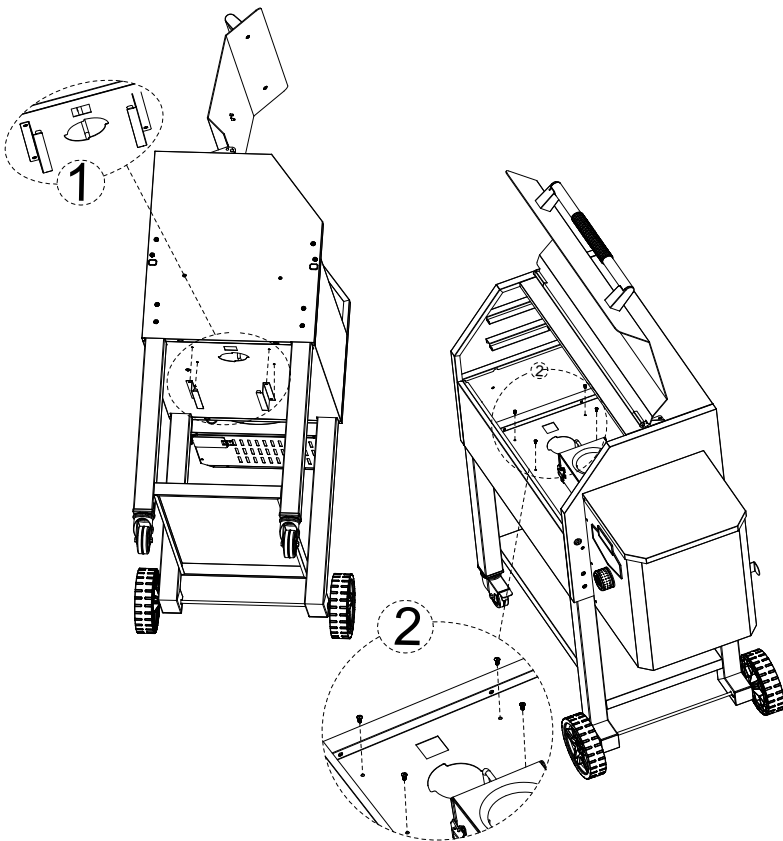

Parts / Hardware Required:

- Grease Tray Bracket (Part #22) x2
-  (Hardware A) x4

Installation:

- Mount Grease Tray Bracket (Part #22)
- Use 4 screws (Hardware A)

STEP 9

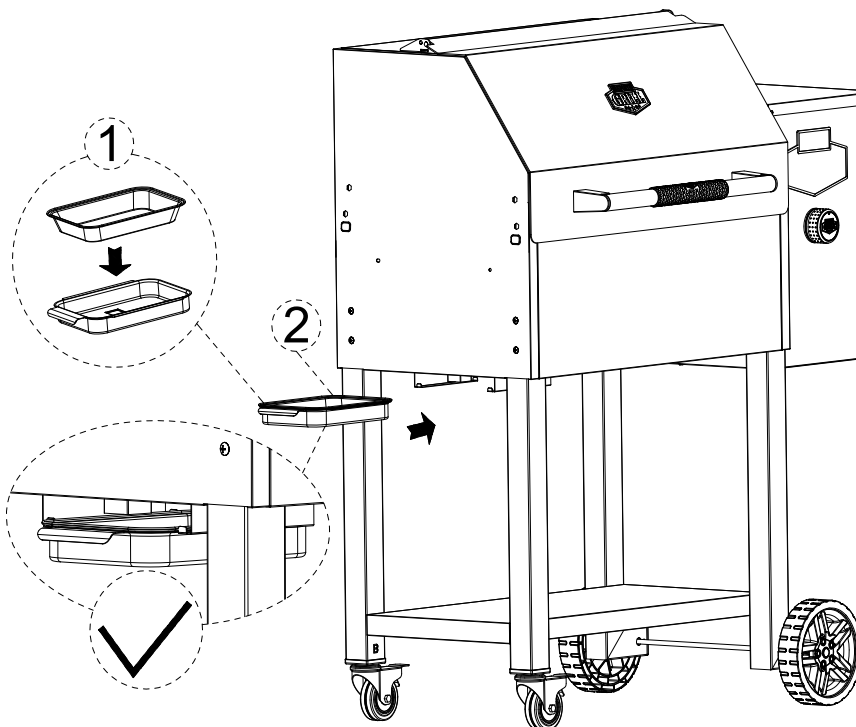

Parts Required:

- Grease Tray (Part #19) x1
- Foil Liner (Part #20) x1

Installation:

- Put the Foil Liner (Part #20) into the Grease Tray (Part #19)
- Place it on the Grease Tray Bracket.

STEP 10

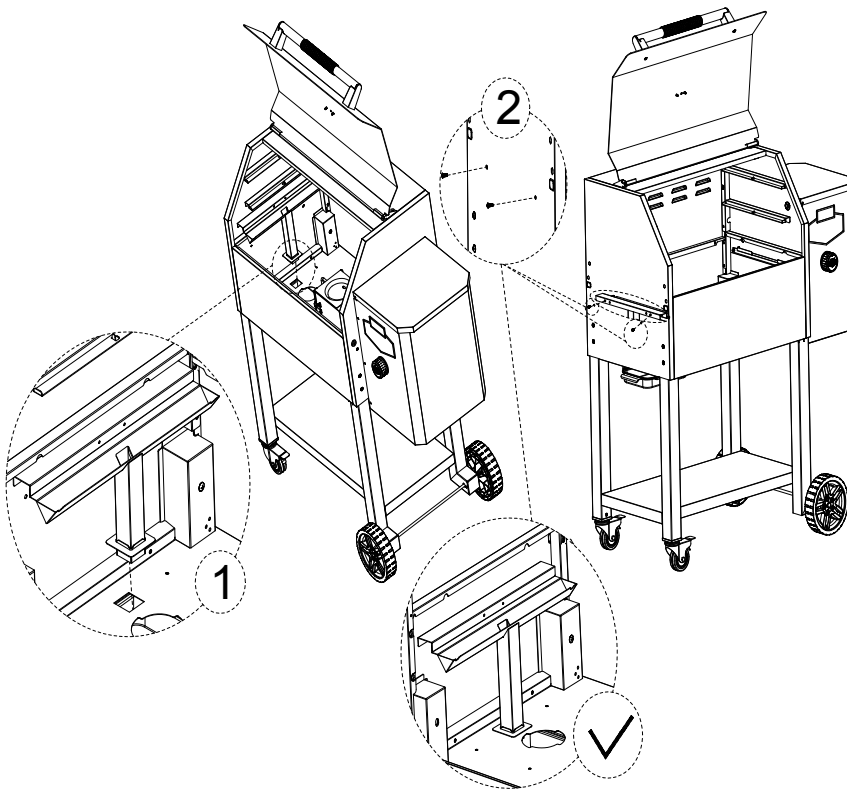

Parts / Hardware Required:

- Grease Guide Assembly (Part #18) x1
-  (Hardware A) x2

Installation:

- Mount Grease Guide Assembly (Part #18)
- Use 2 screws (Hardware A)

STEP 11

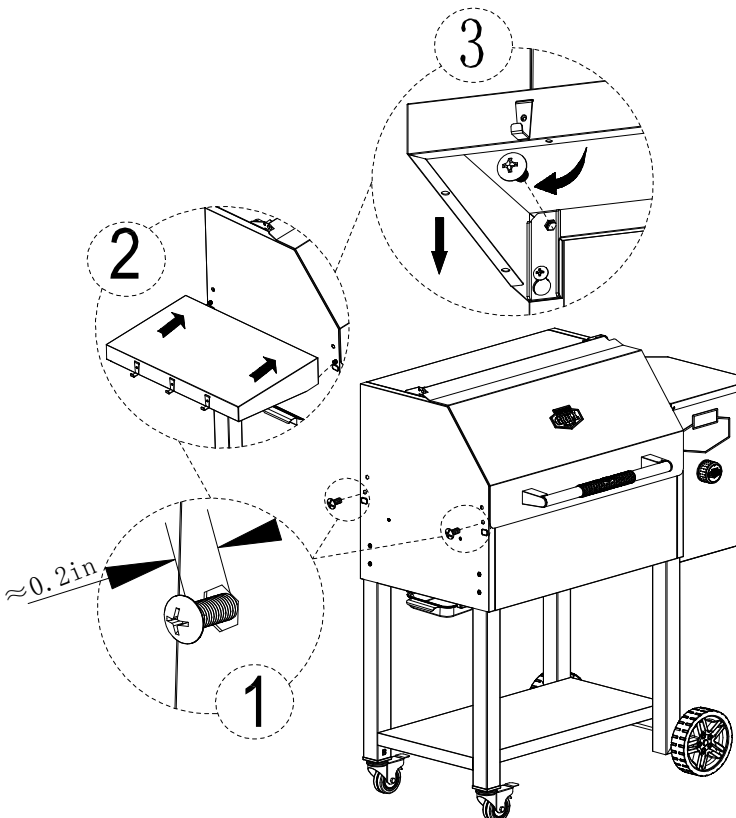

Parts / Hardware Required:

- Side Shelf (Part #17) x1
-  (Hardware B) x4

Installation:

- Pre-thread in the 2 screws (Hardware B) with 0.2 inch of thread exposed.
- Hang Side Shelf (Part #17) on 2 screws (Hardware B). Tighten preinstalled screws.
- Insert 2 screws (Hardware B) in remain.

STEP 12

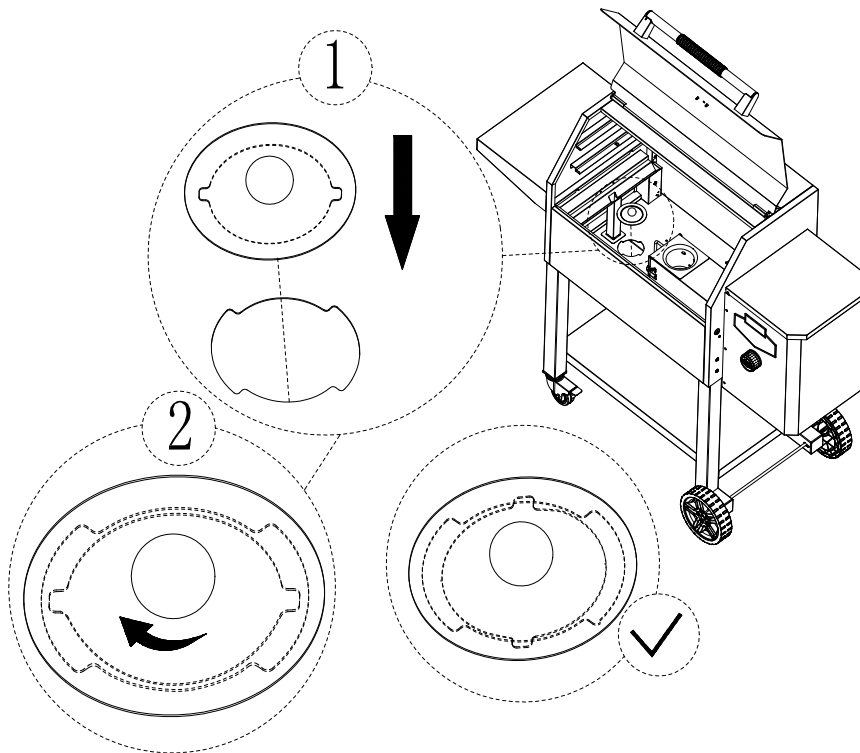

Parts Required:

- Ash Clean-out Cover (Part #21) x1

Installation:

- There are two ears on the back side of Ash Clean-out Cover (Part #21).
- Put this cover into the hole, with 2 ears at orientation shown, then turn 90 degree as shown.

STEP 13

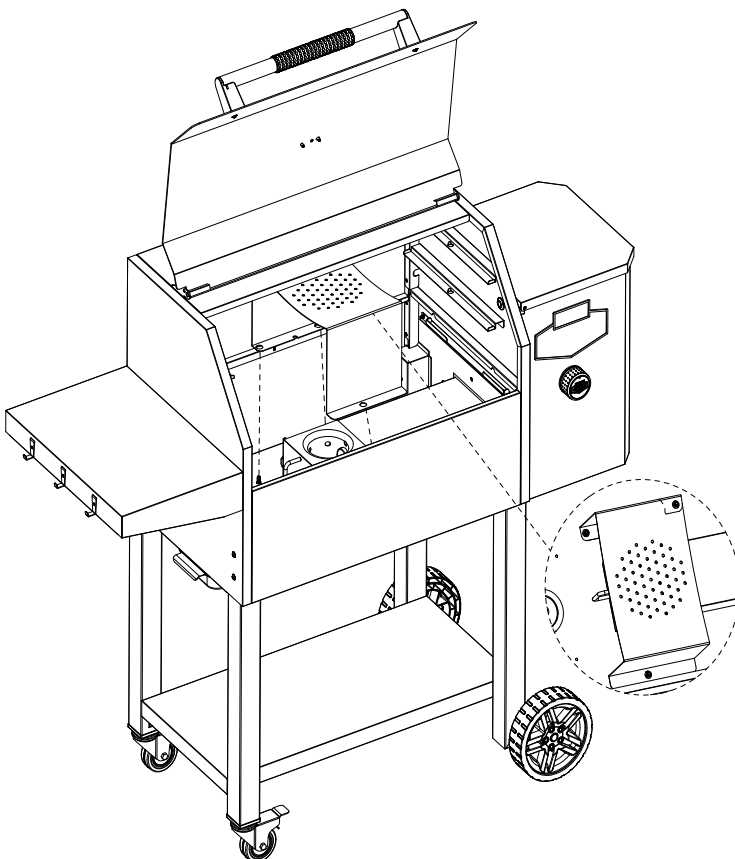

Parts Required:

- Flame Tamer (Part #3) x1

Installation:

- Place Flame Tamer (Part #3) over Fire pot. Locate using 3 Holes .

STEP 14

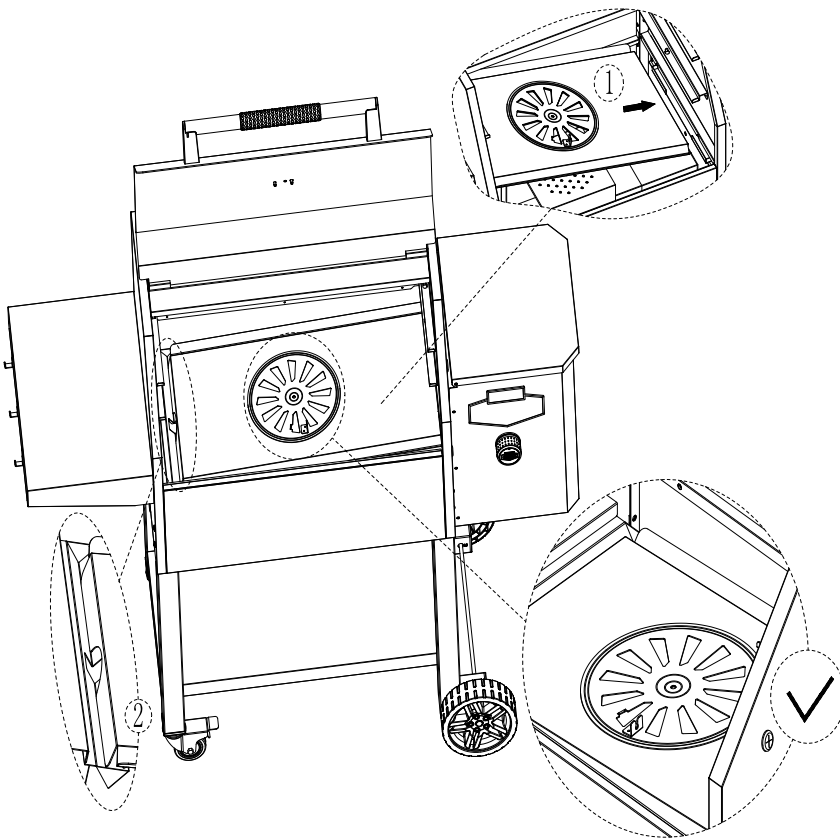

Parts Required:

- Grease Drain Pan (Part #4)
x1

Installation:

- Mount Grease Drain Pan (Part #4) on the firebox. The tab should be placed as shown.

STEP 15

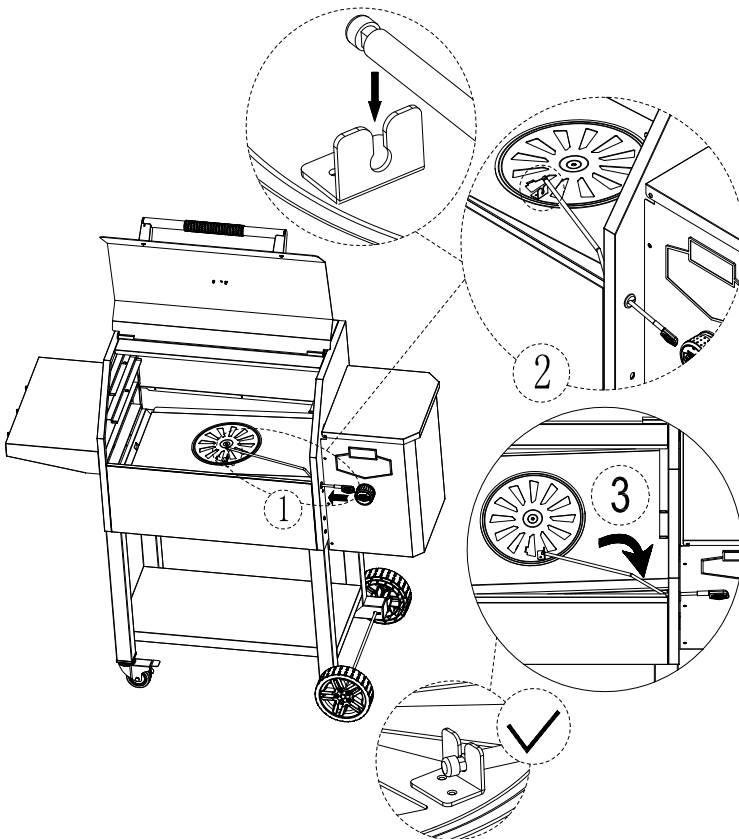

Parts Required:

- Searing Station Pull Handle (Part #6) x1

Installation:

- Insert Searing Station Pull Handle (Part #6) through grommet on side of firebox assembly.
- Align the flat end to the slot as shown. Press it into when Daisy Wheel is open.
- Turn the handle 90 degree as shown to lock well.

Quick cooking food with pushing the handle to open the Daisy Wheel . Normal cooking when pulling the handle out to close the Daisy Wheel.

STEP 16

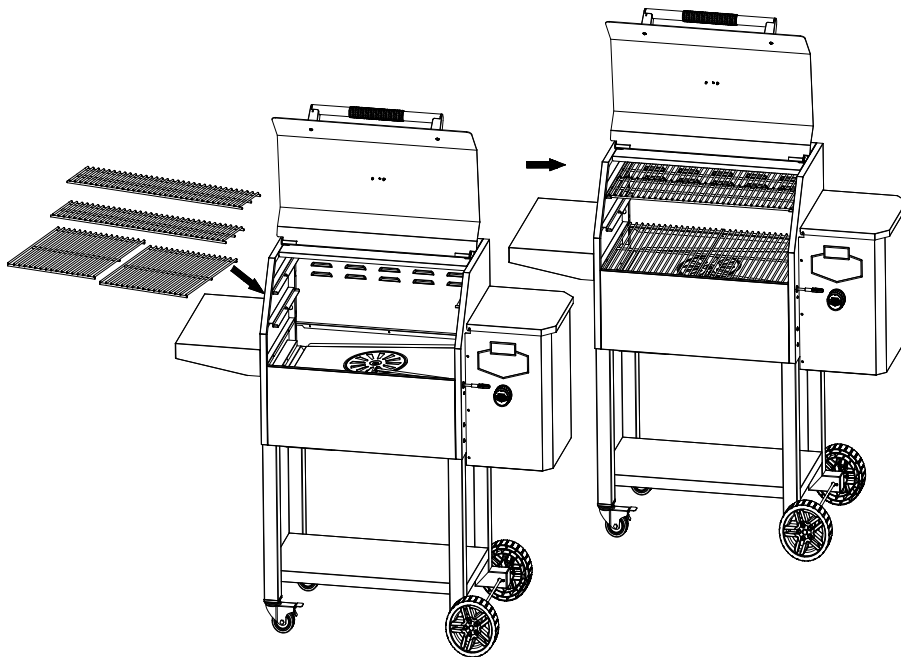

Parts Required:

- Warming Rack (Part #16) x2
- Cooking Grid (Part #15) x2

STEP 17

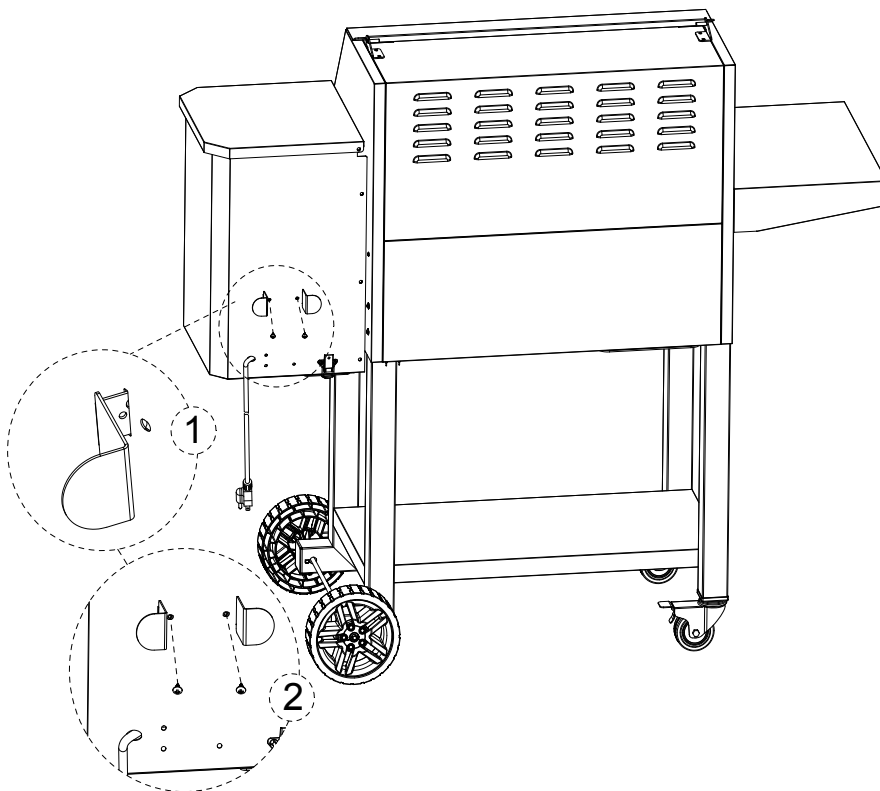

Parts / Hardware Required:

- Power Cord Bracket (Part #23) x2
-  (Hardware F) x2

Installation:

- Insert Power Cord Bracket (Part #23) through slots in backside of Hopper Assembly.
- Insert screw (Hardware F) through hole and tighten.

STEP 18

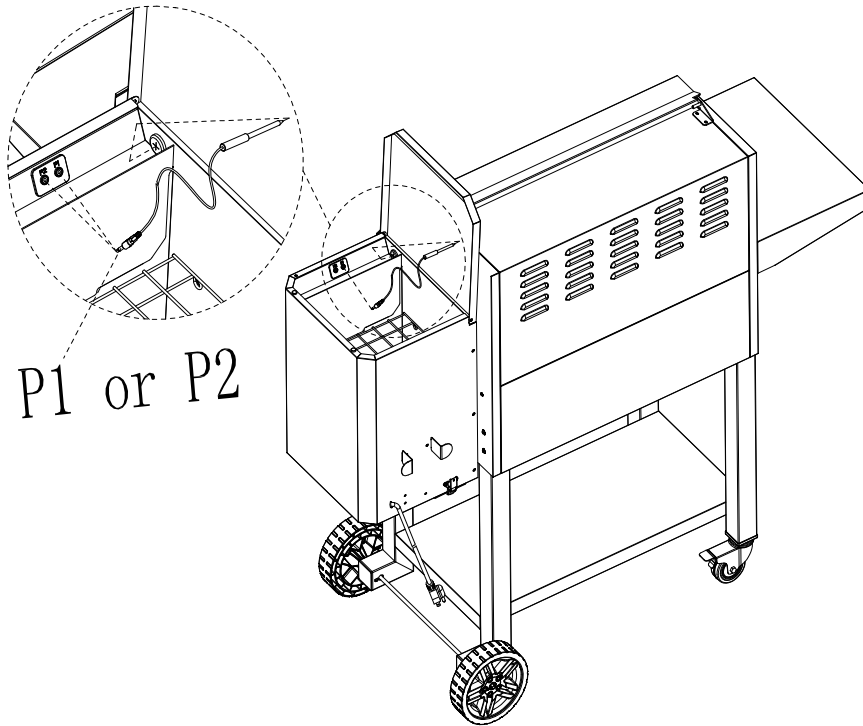

Parts Required:

- Meat Probe (Part #5) x1

Installation:

- Plug the end of meat probe into P1 or P2 port under hopper cap. When a meat probe is connected, the temperature is displayed on the PID screen. When not in use, unplug the meat probe from the connection port.

Use of the Pellet Grill

Placement of the Device

Pellet grills should be placed outdoors in an open and ventilated place with a minimum distance of 2FT on the sides and back. And this clearance must be maintained while the grill is operational. This appliance must not be placed under overhead combustible ceiling or overhang. Keep your grill in an area clear from combustible materials, gasoline and other flammable vapors and liquids.

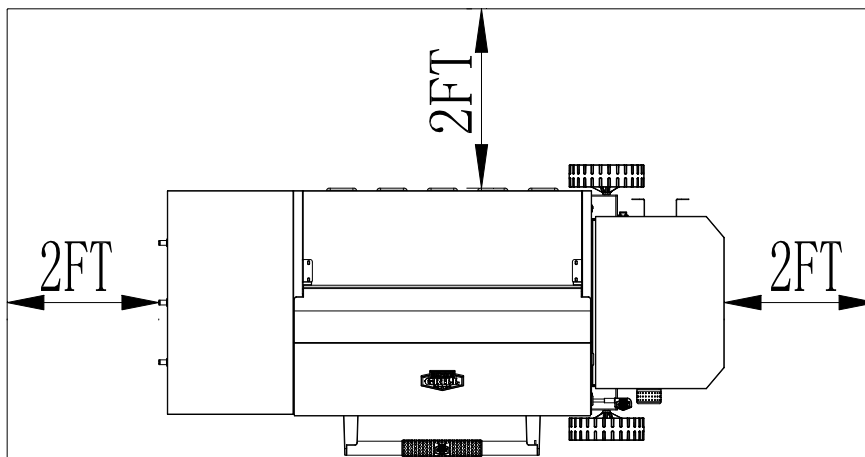

Outdoor Cooking Pellets

Standard Outdoor Cooking Pellets from Walmart should be used in this product.

Pellets should not be more than 1.2" x 0.3", Calorific value is required in the range of 7000-8500 BTU per pound, and Ash content $\leq 1\%$.

Pellets needs to be stored in a dry area, and should never used if exposed to liquid.

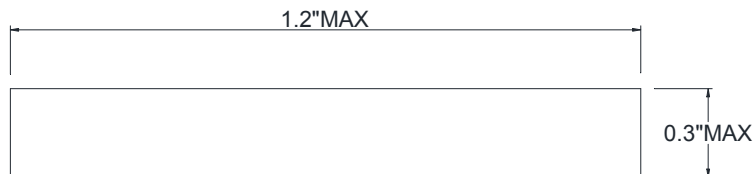





Confirmation before Powering on

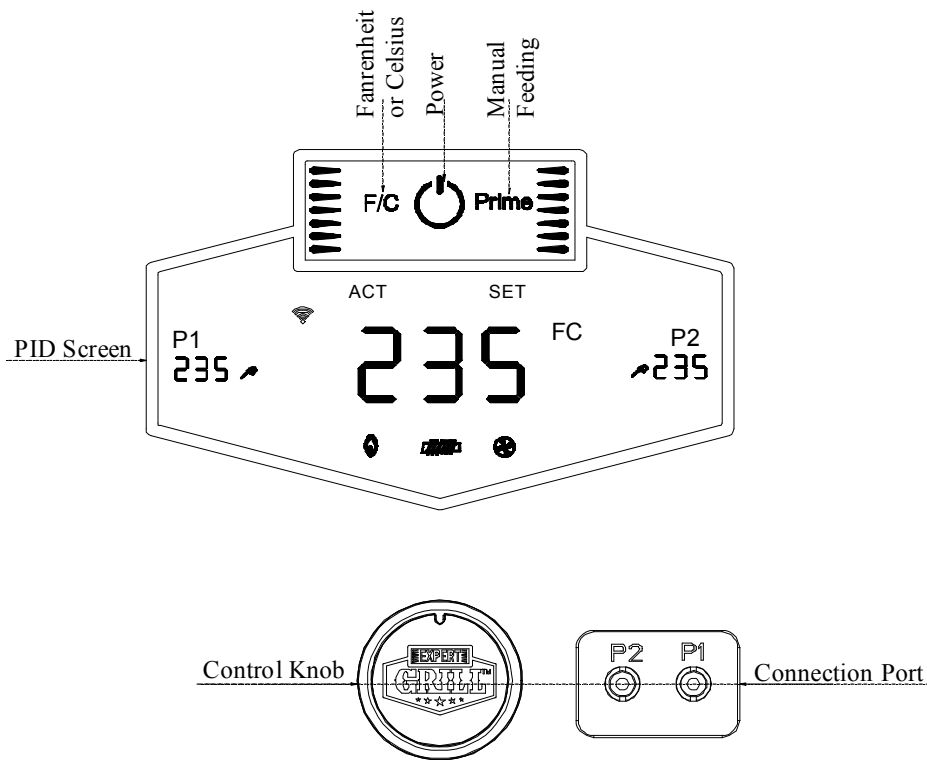



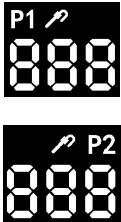

Before powering on the device, you should re-confirm the safety of surrounding power environment, and there is no damp or bare wire in the socket and plug.

Button Function Description



PID Screen:

BUTTON/ICON	DESCRIPTION
	This is power button. Pressure sensitive touch button is used to turn the PID screen "ON", and turn on the grill at same time. Press and hold for 3 seconds, you can turn "OFF" the grill.
	The Temperature unit switch button to change the temperature readout on the PID screen. Press the button to switch between units of temperature Celsius (°C) or Fahrenheit (°F), as preferred. Default is set to Fahrenheit.
	When this touch button is pressed and held, the FEED system will feed more pellets to the fire pot. This can be used to add more pellets for the first use of the grill or if there is not enough pellets in the fire pot. It can also be used to add more pellets while smoking to increase the amount of smoke flavor intensity.
	The plug-in connection port(s) under the hopper cap are for Meat Probe(s). When a meat probe is connected, the temperature is displayed on the PID screen. When not in use, unplug the meat probe from the connection port. There are two (2) connection port(s). Compatible with EXPERT GRILL® branded meat probes only. Additional meat probe(s) sold separately.
	"ACT" displays the actual temperature of your grill at that moment of time. Press the control knob once to switch between "SET" and "ACT". By default, PID screen displays "ACT".

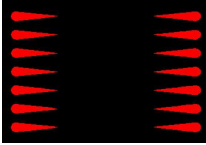
	Press and turn the control knob (When "SET" selected as shown) to select your desired temperatures, between 180°F~450°F.
	This Bluetooth icon will flash after the grill is turn on. It will stop flashing when the device is connected with your phone.
	This icon will always light after the grill is turn on.
	The Igniter icon displays ignition of your pellets. If this symbol is flashing and the PID screen displays Err, then it means that your igniter is not working.
	The Fan icon displays the switching on of the fan. If this symbol is flashing and the PID screen displays Err, then it means that your fan is not working.
	The Auger icon displays the switching on of your auger motor. Sometimes this symbol flashing and the PID screen displays Err showing that the auger is not working.
	Temperature indicator Under 100°F, one grid on; 100°F~167°F, two grids on; 167°F~234°F, three grids on; 234°F~300°F, four grids on; 300°F~367°F, five grids on; 367°F~434°F, six grids on; Above 434°F, seven grids on; The grids will be lighted one by one when the temperature is rising.

Control Knob:

The control knob allows you to set your desired grill temperature. Once connected to a power source and the power button is pressed. Then you can choose **Smoke mode** or **Cooking mode**.

When you turn on the grill, the default set is Smoke mode. PID screen displays actual temperature. When you press the control knob, it will show  in the middle of PID screen.

If you need Cooking mode, you can set your desired temperature through control knob. The temperature will increase 5°F when you turn the control knob once in clockwise. The temperature will decrease 5°F when you turn the control knob once in anticlockwise. The setting range is 180°F~450°F.

If temperature is above 450°F, it will show "H" in the middle of PID screen.

If the temperature is bellow 180°F, it will show  in the middle of the PID screen, and the grill is under Smoke mode.

Press the control knob or wait for 5 seconds to lock your preset temperature, and get back to Actual Grill Temperature.

Ignition Instructions

Before powering on the device, you should re-confirm the safety of surrounding power environment, and there is no damp or bare wire in the socket and plug.

Open the pellet hood, check the fire pot to ensure there is no obstruction for proper ignition.

Before each ignition, please clean up the residual ash in the fire pot. And put a small amount of pellets into the fire pot in the first use. Then put the flame tamer, grease drain pan and cooking grids successively, and close the hood.

⚠ WARNING: Before placing pellets into the fire pot, make sure the grill is NOT on, and Fire Pot is NOT hot to prevent possible skin burn.

Open the hopper cap, ensure there are no foreign objects in the hopper or auger system. And check the pellet level, add more pellets if necessary.

Plug the Power Cord into an appropriate, grounded electrical outlet. Press the power button to turn on. Please press "Prime" to start the auto FEED system to feed more pellets to the fire pot. This can be used to add more pellets for the first use of the grill or if there is not enough pellets in the fire pot. The igniter will begin to glow and the fan will supply air to the fire pot. The grill will begin to produce smoke.

Once the heavy, white smoke has dissipated, the Ignition is complete, and you are ready to enjoy your grill at your desired temperature!

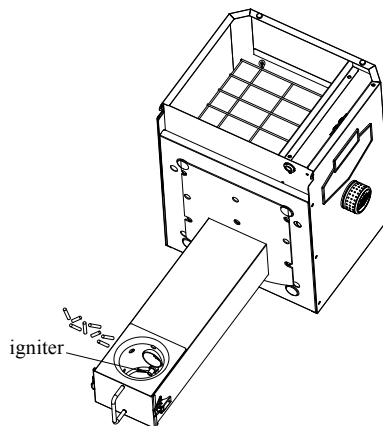

To safely turn off the grill follow the steps below :

1. Open the hopper cap, remove the residual pellets from the hopper and store pellets in a cool, dry place for next use.
2. Let the grill continue to work 5 to 10 minutes to use up the pellets in the feeder.
3. Press and hold Power button for 3 sec to turn off, but do not unplug the power right now. At this time, the cooling fan will continue to work for some minutes until the pellets is burned off and extinguished.
4. Finally, unplug the power, and store the grill in a cool and ventilated place to avoid sun exposure and heavy rain.

Cooking Instructions

Breaking In the Grill

Before cooking on your grill for the first time, it is important to start the grill and operate at 350°F for half an hour to season the grill.

Cooking

Once the grill is ignited, you can begin cooking by selecting any of the cooking temperatures.

Cooking should be done with the hood closed only. If the hood is left open the feed rate will increase and the temperature will overshoot. You should cook all meat using the meat probe to ensure that the internal temperature of the meat reaches the recommended temperature for the finish desired.

Meat Probes

This pellet grill has a built in meat probe to measure the temperature of the food as it is being cooked. To use the meat probe, first insert the meat probe into the food, then plug the connectors into the connection port (P1 or P2) under the hopper cap. The temperature is displayed on the PID screen.

Cleaning

Clean grates using a wire grill brush. This should be done with each use. DO NOT use oven cleaner or abrasive cleaners on the painted grill surfaces. Use warm soapy water on all painted surfaces. Clean grease pan, grease trough, and grease drain tube occasionally. A spatula can be used to scrape excess grease and a grill brush to brush clean. Do not allow grease to build up on the grease tray or in the grease trough as this can cause flare-ups inside the grill. Make sure not to obstruct the flow of grease off to the tray and into the grease trough. Make sure not to block the airflow to the temperature sensor on the left side of the grill.

Ashes Clean-out

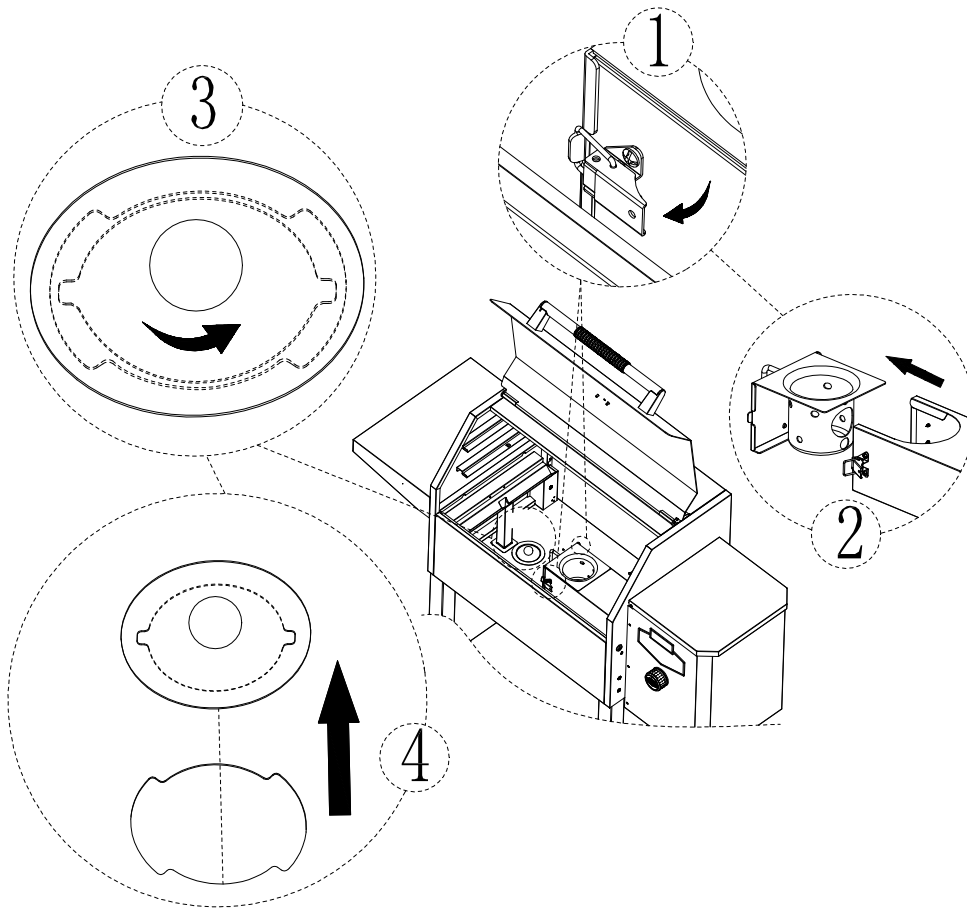

Before each time to use grill or after used (must let grill cool down completely), remove cooking grids, grease drain pan and flame tamer successively.

Fire Pot Ashes Clean-out

1. Loosen the buckles of fire pot.
2. Take out the fire pot and discard the ashes.

⚠ WARNING: Before disposing of Ashes, make sure the ash is completely free of hot embers to prevent possible fire.

Firebox Ashes Clean-out

1. Turn Ash Clean-out Cover and remove it as shown above.
2. Remove firebox ashes through this hole into the grease tray and discard.

⚠ WARNING: Before turning grill on clean out residual ashes in the fire pot to prevent back draft into Pellet Hopper and possible fire.

Pellet Hopper Clean-out

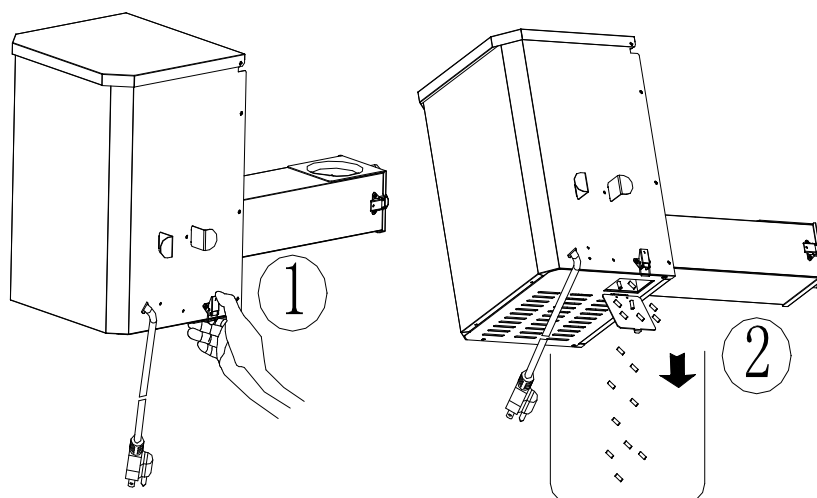

If grill will be left un-attended for a long period of time, we recommend you remove unused pellets. Always store wood pellets away from heat and in a dry location.

1. lift Clean-out handle Lock
2. Open Hopper Clean-out door

Note: Make sure to hold a pail or bag in place before emptying pellets.

Cleaning and Maintenance

- Keep the appliance free and clear of combustible materials, gasoline and other flammable vapors and liquids.
- For safe grilling and peak performance of your grill, perform these checks at least twice per year or after extended periods of storage.
- Be sure to tighten up all hardware (nuts, bolts, screws, etc.) at least twice per year.

⚠ CAUTION: Some parts may contain sharp edges. Wear protective gloves if necessary.

- Remove the cooking grates, from inside your grill. Use a brush with hot water and detergent to remove excess residue.

NEVER use a commercial oven cleaner. Rinse completely with water.

Towel dry and replace all components as described in the assembly instructions.

Connection of the App

1. Search " Expert Grill" in iOS store or Play store to download the APP.
2. After download the APP, initiate Bluetooth function of your phone,  on PID screen will stop flashing when the device is connected with your phone, and click the APP to search the devices.

If it is first use/connect, we suggest final customer to connect the phone to PID face to face or within 16.4 feet (5 meters) without any obstacles.

After the first successful connection, the Bluetooth operation distance is within 164 feet (50 meters) without any obstacles, and within 82 feet (25 meters) if there is a wall or window.

3. If the search is successful, the searched devices will be displayed. Each device has a unique number with a name such as Expert Grill_XXX.





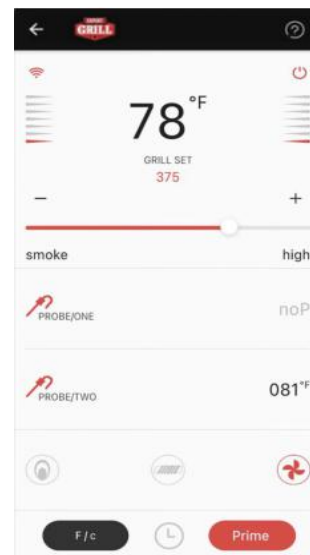

If the search is unsuccessful, a second page is displayed. Request to try again.





4. Click the Expert Grill_XXX and come to the home page



5. Functions on main interface

	Turn on/off
	This button can switch between Celsius and Fahrenheit.
	Push this button can start the forced feeding. The PID screen "Prime" will become red.
	These are not touchable icons, they will display same status as on PID screen.
	Timer Alarm: users can set the cooking time (period), and when the cooking time is up, the phone will keep ringing. Timing time up to 12 hours.
	You can find Manuals, Assembly Video and Customer Support in this help button.

6. How to set temperature: You can choose anyone from 3 versions below.

6.1 Click  , you can set the temperature of the grill  , you can follow the instructions in gray and set from 180°F to 450°F. Under 180°F shows "smoke", above 450° F is "high".

6.2 Click | - and + to adjust the temperature, the temperature will increase 5°F by each press and increase 25°F by long press (2s) of + , and it will decrease 5°F by each press and decrease 25°F by long press (2s) of | - .

6.3  There are two ways to use the slider. You can touch any point on the slider and the dot will slide to the position. Press the finger on the slider to move left and right, and determine the value according to the last position of the finger.

7. How to set meat probe temperature

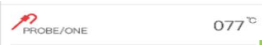
Click  or  can set the temperature of the meat probe.

 You can follow the instructions in gray and set form 80°F to 250°F. Exceeding the setting range will be invalid.

Troubleshooting

⚠ WARNING: Before troubleshooting, make sure the power is turn off, the grill in turn off.

Problem	Cause	Solution
PID Screen Not Turn ON	<ul style="list-style-type: none"> ● Grill is not properly plugged in. 	<ul style="list-style-type: none"> ● Ensure all wire connections are firmly connected. ● Ensure grill is plugged into a working GFCI outlet.
	<ul style="list-style-type: none"> ● The circuit board fuse has been tripped. 	<ul style="list-style-type: none"> ● Fuse must be manually replaced.
	<ul style="list-style-type: none"> ● The GFCI outlet has been tripped. 	<ul style="list-style-type: none"> ● Ensure all wire connections are firmly connected and dry. ● Ensure GFCI is a minimum 10 Amp service.
“Err” and Fan icon is flashing	<ul style="list-style-type: none"> ● Fan not plugged in or damage 	<ul style="list-style-type: none"> ● Ensure Fan wire is connected correctly to PID screen. ● Confirm wire connections and replace if has any damage.
“Err” and Igniter icon is flashing	<ul style="list-style-type: none"> ● Igniter not plugged in or damage 	<ul style="list-style-type: none"> ● Ensure Igniter wire is connected correctly to PID screen. ● Confirm wire connections and replace if has any damage.
“Err” and Auger icon is flashing	<ul style="list-style-type: none"> ● Auger not plugged in or damage 	<ul style="list-style-type: none"> ● Ensure Auger wire is connected correctly to PID screen. ● Confirm wire connections and replace if has any damage.
“ErH”	<ul style="list-style-type: none"> ● The grill has overheated, due to grease fire or excess pellets. 	<ul style="list-style-type: none"> ● Turn the grill off and allow to cool. ● Clean grill interior, remove excess pellets
“ErP”	<ul style="list-style-type: none"> ● Thermal probe not plugged in or damage 	<ul style="list-style-type: none"> ● Thermal probe not being used. ● Ensure thermal probe wire is connected correctly to PID screen. ● Confirm wire connections and replace if has any damage.

“ErL”	<ul style="list-style-type: none"> ● Insufficient or poor pellets 	<ul style="list-style-type: none"> ● Check and remove fire pot ash build-up, obstructions and that it is seated properly in the firebox. ● Ensure igniter is heating up and positioned correctly. ● Check fans to confirm operation and speed. ● Ensure hopper has sufficient standard pellets. ● Press "Prime" or put a small amount of pellets into fire pot.
-------	--	--

Problem	Cause	Solution
Igniter does not work	<ul style="list-style-type: none"> ● Insufficient air flow 	<ul style="list-style-type: none"> ● Check and remove fire pot ash build-up, obstructions and that it is seated properly in the firebox.
	<ul style="list-style-type: none"> ● Igniter rod is not work 	<ul style="list-style-type: none"> ● Check to confirm igniter DOES NOT get hot. When you check it, DO NOT TOUCH the igniter or the housing, you may will get burnt. ● Check on placement of the igniter rod to the fire pot. ● Cut off the power, remove baseboard of hopper, ensure wire connectors are tight.
Produces excess or discolored smoke	<ul style="list-style-type: none"> ● Excess grease build-up 	<ul style="list-style-type: none"> ● Check and clean the interior grilling area. ● It is a good practice to clean and do a controlled burn off the hidden excess grease after each large cooking of tasty greasy foods.
	<ul style="list-style-type: none"> ● Pellets wet 	<ul style="list-style-type: none"> ● Check and clear the hopper and fire pot of moist pellets, replacing them with fresh dry pellets.
	<ul style="list-style-type: none"> ● Excess pellets 	<ul style="list-style-type: none"> ● Check and remove excess pellets in the hopper.

Frequent Flare- ups	<ul style="list-style-type: none"> ● Cooking temperature is too high 	<ul style="list-style-type: none"> ● Set the temperature lower. ● Grease does have a flash point, keep the temperature under 350°F when cooking highly greasy food.
	<ul style="list-style-type: none"> ● Excess grease build-up 	<ul style="list-style-type: none"> ● Check and clean the interior grilling area. ● It is a good practice to clean and do a controlled burn off the hidden excess grease after each large cooking of tasty greasy foods.
P1 or P2 Temp shows 32° F. It has no change after the grill is heated.	<ul style="list-style-type: none"> ● Meat probe is dirty 	<ul style="list-style-type: none"> ● Use a soft cloth or mild abrasive sponge, along with hot water and soap to wipe clean the meat probe.
	<ul style="list-style-type: none"> ● Meat probe wire is wet 	<ul style="list-style-type: none"> ● Open the hopper cap and remove the meat probe. ● Use a hair dryer to dry the meat probe wires.
Temperature not stable	<ul style="list-style-type: none"> ● No setting Cooking mode 	<ul style="list-style-type: none"> ● Ensure control is set on Cooking mode.
	<ul style="list-style-type: none"> ● Insufficient air flow 	<ul style="list-style-type: none"> ● Check and remove fire pot ash build-up, obstructions and that it is seated properly in the firebox. ● Ensure that both the fire pot and firebox are seated properly with no air leakage. ● Ensure the fan for proper operation, that it is working, that the air intake is not blocked and that there is no blockage in the hopper.
	<ul style="list-style-type: none"> ● Insufficient or poor pellets 	<ul style="list-style-type: none"> ● Ensure hopper has sufficient pellets. ● Ensure pellets is standard wood pellets. ● Press and hold the Prime button. Ensure the auger is working and turning freely. ● Check and clean the meat probe.

Input Voltage : AC110V ~ AC120V 60HZ

Max power : 250W

Power of auger : 25W \pm 10%

Power of fan : 25W \pm 10%

Power of fire rod : 200W \pm 10%

Probe type : PT1000

Display :

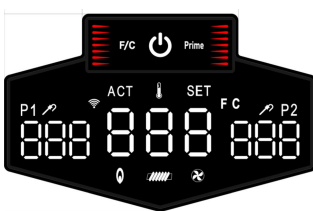

Wiring diagram :

Red white (auger), yellow white (fan), purple white (fire rod), black white (power cord)

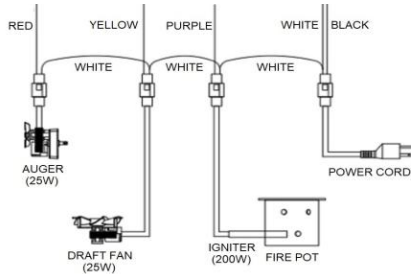

Warranty

Two-Year Full Warranty

If this grill fails due to a defecting material or workmanship within one year from the date of purchase, call 855-256-2160 to arrange for free repair (or replacement if repair proves impossible).

All warranty coverage excludes ignitor and grill part paint loss, discoloration, or rusting, which are either expendable parts that can wear out from normal use within the warranty period, or are conditions that can be the result of normal use, accident, or improper maintenance.

All warranty coverage is void if this grill is ever used for commercial or rental purposes.

All warranty coverage applies only if this grill is used in the United States.

This warranty gives you specific legal rights, and you may have other rights which vary from state to state.

Customer Service

If you have any questions or if you need replacement parts, please contact our customer service:

855-256-2160

expertgrill@grillservices.net

We're pleased to help you with any question concerning replacement parts or your warranty. Our customer service staff can be reached **8 AM - 4:30 PM Eastern Time, Monday to Friday.**