



PELLET SMOKER & GRILL

OWNER'S MANUAL

ASSEMBLY AND OPERATING INSTRUCTIONS

SAVE THIS MANUAL FOR FUTURE REFERENCE

Model SMK8028AS

NOTICE TO INSTALLER:
LEAVE THESE
INSTRUCTIONS WITH THE
GRILL OWNER FOR
FUTURE REFERENCE.

⚠ WARNING

PLEASE READ THIS ENTIRE MANUAL BEFORE INSTALLATION AND USE OF THIS PELLET FUEL-BURNING APPLIANCE. FAILURE TO FOLLOW THESE INSTRUCTIONS COULD RESULT IN PROPERTY DAMAGE, BODILY INJURY OR EVEN DEATH. CONTACT LOCAL BUILDING OR FIRE OFFICIALS ABOUT RESTRICTIONS AND INSTALLATION INSPECTION REQUIREMENTS IN YOUR AREA. SAVE THESE INSTRUCTIONS.



IMPORTANT SAFETY WARNINGS

WE WANT YOU TO ASSEMBLE AND USE YOUR SMOKER AS SAFELY AS POSSIBLE.

THE PURPOSE OF THIS SAFETY ALERT SYMBOL ⚠

IS TO ATTRACT YOUR ATTENTION TO POSSIBLE HAZARDS AS YOU ASSEMBLE AND USE YOUR SMOKER/GRILL.
WHEN YOU SEE THE SAFETY ALERT SYMBOL, PAY CLOSE ATTENTION TO THE INFORMATION WHICH FOLLOWS!

- ⚠ READ ALL SAFETY WARNINGS AND INSTRUCTIONS CAREFULLY
BEFORE ASSEMBLING AND OPERATING YOUR SMOKER/GRILL.

⚠ WARNING

⚠ Do NOT use in humid or wet conditions

⚠ WARNING

1. Improper installation, adjustment, service or maintenance can cause injury or property damage.
2. Read all instructions and guidelines carefully and thoroughly before installation, use or service.
3. Failure to follow these instructions could result in fire or electrical shock.

⚠ DANGER

⚠ NOT for use in or on boats or recreation vehicles.

⚠ DANGER



1. Do not store or use gasoline, liquid propane or any other flammable vapors or liquids in the vicinity of this appliance.

A MAJOR CAUSE OF FIRES IS FAILURE TO MAINTAIN REQUIRED CLEARANCES (AIR SPACES TO COMBUSTIBLE MATERIALS). IT IS OF UTMOST IMPORTANCE THAT THIS PRODUCT BE INSTALLED ONLY IN ACCORDANCE WITH THESE INSTRUCTIONS.

TABLE OF CONTENTS:

General Warnings	3-4
Operating the Grill	5-8
Proper Care and Maintenance	9
Transporting and Storage.	10
Grill Cooking Tips.	10
Trouble Shooting	11
Assembly Instructions	12-22
Warranty Information	Back Cover

⚠ DANGER: Indicates an imminently hazardous situation which, if not avoided, will result in death or serious injury.

⚠ WARNING: Be alert to the possibility of serious bodily injury if the instructions are not followed. Be sure to read and carefully follow all of the messages.

⚠ CAUTION: Indicates a potentially hazardous situation which, if not avoided, may result in minor or moderate injury.

CALIFORNIA PROPOSITION 65 WARNING

⚠ WARNING: This product can expose you to chemicals, including carbon monoxide, which are known to the State of California to cause birth defects or other reproductive harm.

For more information go to www.P65Warnings.ca.gov

⚠ WARNING: CONTAINS LEAD. MAY BE HARMFUL IF EATEN OR CHEWED. COMPLIES WITH FEDERAL STANDARDS. KEEP OUT OF REACH OF CHILDREN.

For accessories and other products, please visit us at:
www.evenembers.com

GENERAL WARNINGS:

⚠ WARNING

When using electric appliances, basic safety precautions should always be followed including the following:

- Operate only per manufacturers instructions.
- Keep all combustible materials at least 36 inches (66 cm) away from the grill at all times. Do not use this grill under any overhang or near any combustible structures.
- Minimum clearance from side and back of unit to combustible materials, 36 inches (66 cm) from side and 36 inches (66 cm) from back.
- DO NOT use on wood decks. Set up this grill on a hard, non-combustible smooth level surface.
- In case of fire, turn the control "OFF!" Unplug the grill from the power source and allow the fire to burn out on its own. Do not use water to try to extinguish a fire.
- Keep a fire extinguisher on hand acceptable for use with electric products. Refer to your local authority to determine proper size and type.
- Creosote – Formation and need for removal. When wood pellets are burned slowly, they produce tar and other organic vapors that combine with expelled moisture to form creosote. The creosote vapors condense in a relatively cool oven flu and exhaust hood of a slow burning fire. As a result, creosote residue accumulates on the flue lining and exhaust hood. When ignited, this creosote makes an extremely hot fire.
- The grease duct should be inspected at least twice a year to determine when grease and/or creosote buildup has occurred.
- When grease or creosote has accumulated, it should be removed to reduce risk of fire.
- Do not attempt to touch cooking surfaces or other hot surfaces. Use handles or knobs.
- To protect against electric shock, do not immerse cord, plugs, or heating element in water or any other liquids.
- Never leave appliance unattended. Hot while in operation. Keep children, clothing and furniture away. Contact may cause burns.
- Unplug this grill from the power source when not in use and before cleaning. Allow appliance to cool down before attempting to clean or service.
- Do not operate any appliance with a damaged power cord or plug, or after the appliance has malfunctioned or been damaged in any manner.
- Do not use accessories or attachments not recommended by the manufacturer, as they may not be compatible with this appliance, and may cause damage or injury.
- Do not place power cord where it may come in contact with hot surfaces, or pose a tripping hazard.
- Do not use this appliance for anything other than its intended use.
- NEVER add cooking pellets to a hot fire pot by hand. You could be seriously burned. If the hopper runs out of pellets or your fire goes out while cooking, let the grill completely cool and follow the Initial Lighting Instructions.
- Use only cooking grade wood pellets. Never use heating grade wood pellets as they are not safe for cooking.
- Always store wood pellets away from heat.
- NEVER use gasoline, gasoline-type lantern fuel, kerosene, charcoal lighter fluid, or similar liquids to start or "freshen up" a fire in this appliance. Keep all such liquids well away from the appliance when in use.
- This grill is not for use indoors. Do not use inside a building, garage or any other enclosed area.
- This product is not designed for commercial use.

- This product is not designed for tabletop use. Do not set this product on a tabletop.
- Outdoor extension cords must be used with outdoor use products and are marked with suffix “W” and with the statement “Suitable for Use with Outdoor Appliances.”
- Only use a properly-grounded power source.
- Use only with a properly-grounded GFCI (Ground Fault Circuit Interrupter) household circuit.
- Do not operate this product in rain or wet conditions. Do not allow this product to come in contact with water. Set this product up more than 10’ from any large body of water (swimming pool, lake, pond, etc).
- CAUTION - To reduce the risk of electric shock, keep extension cord connection dry and off the ground.
- Never alter or remove the grounding plugs on the power cord or household outlet.
- Disconnect electric cord from outlet before cleaning.
- Keep appliance clean. See Proper Care and Maintenance section for cleaning.
- Do not operate this grill while under the influence of drugs, alcohol, or while fatigued.
- Do not use in the presence of explosive or flammable gases, vapor or other substances.
- Do not use this grill unless it is completely assembled and all parts are securely fastened and tightened.
- Use only identical replacement parts.
- Do not use this product in high winds.
- Do not attempt to move this appliance while it is in use.
- Always open the grill lid carefully - heat and steam trapped inside the lid can burn.
- Do not use this product for indoor heating, as toxic fumes will accumulate.
- After a period of storage, inspect the grill for abrasion, wear, cuts, or damage to the temperature controller and power cord.
- Always use a meat thermometer to ensure food is cooked to a safe temperature.
- Keep grill covered when not in use - out of the reach of children. Do not clean this product with a water spray or the like.
- Unplug from outlet when not in use and before cleaning. Allow to cool before putting on or taking off parts.
- Do not operate any appliance with a damaged cord or plug or after the appliance malfunctions or is dropped or damaged in any manner.

Follow these guidelines to prevent this colorless, odorless gas from poisoning you, your family or others.

- Know the symptoms of carbon monoxide poisoning; headache, dizziness, weakness, nausea, vomiting, sleepiness and confusion. Carbon monoxide reduces the blood’s ability to carry oxygen. Low blood oxygen levels can result in loss of consciousness and death.
- See a doctor if you or others develop cold or flu-like symptoms while cooking or in the vicinity of this appliance. Carbon monoxide poisoning, which can easily be mistaken for a cold or flu, is often detected too late.
- Alcohol consumption and drug use increase the effects of carbon monoxide poisoning.
- Carbon monoxide is especially toxic to mother and child during pregnancy, infants, the elderly, smokers and people with blood or circulatory system problems, such as anemia or heart disease.

⚠ USE CAUTION AND COMMON SENSE WHEN OPERATING YOUR PELLET SMOKER & GRILL. FAILURE TO ADHERE TO THE SAFETY WARNINGS AND GUIDELINES IN THIS MANUAL COULD RESULT IN SEVERE BODILY INJURY OR PROPERTY DAMAGE. SAVE THIS MANUAL FOR FUTURE REFERENCE.

OPERATING THE GRILL:

⚠ WARNING

Read and follow all warnings and instructions contained in the preceding sections of this manual.

BREAKING IN YOUR GRILL:

- In manufacturing and preserving the components of your grill, oil residue may be present on the cooking surfaces of your grill.
- Before cooking on your grill for the first time you should follow “Initial Lighting Instructions” to ensure the auger is fully charged with pellets.

PREHEATING GRILL:

- Prior to use, it is recommended that you preheat your grill. This ensures that the grilling surfaces are at the desired temperatures to sear the food sugars when cooking. Preheat the grill for 10 to 15 minutes or until it reaches the desired temperature before adding food. Close the lid during the preheat period.

⚠ WARNING

- **DO NOT leave your grill unattended while in use.**
- **DO NOT move grill when in use. Block wheels in place to stabilize grill.**
- **DO NOT use water to extinguish flare-ups.**

IF AN EXTENSION CORD IS NECESSARY:

- Use a CSA or UL approved 3-prong grounded extension cord that is rated for at least 7-10 Amp and is marked as suitable for outdoor use.
- Keep the power cord connection dry and off of the ground.
- Avoid running the power or extension cord across walkways, driveways, or anywhere where it could pose a tripping hazard.

TURNING ON THE GRILL:

Initial Lighting Instructions (To be used on initial firing or anytime the grill runs out of pellets)

Always allow the auger tube to fully load with pellets to ensure proper lighting of the grill.

- Step 1** Open lid to cooking chamber and remove cooking grills, grease tray and heat baffle from inside the grill. Leave door open.

- Step 2** Make sure temperature control knob is “OFF”. Plug power cord into a GFCI (grounded) outdoor electrical outlet.
- Step 3** Open the pellet hopper lid. Make sure the auger is free from debris and other objects. Turn the temperature control knob to “SMOKE”
- Step 4** In the cooking chamber, place your hand about 3” above the fire pot and make sure you can feel air blowing out from the fire pot.

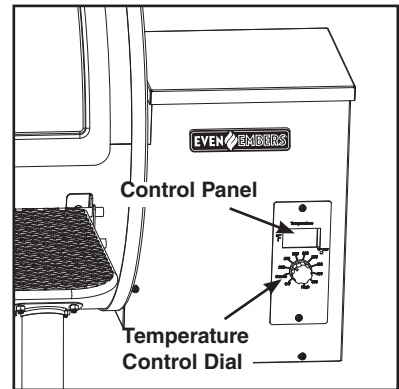

- Step 5** Look inside the fire pot and make sure the heating element is getting hot. It will take a couple of minutes for the element to glow red. **DO NOT TOUCH THE HEATING ELEMENT!** Turn temperature control knob to “OFF”
- Step 6** Fill the pellet hopper with cooking pellets. **NEVER USE HEATING FUEL PELLETS AS THEY ARE NOT SAFE FOR COOKING.**

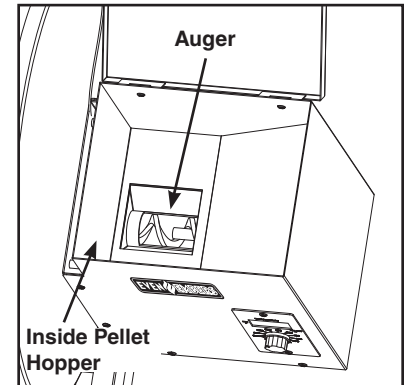

- Step 7** Turn the temperature control knob to “SMOKE”
- NOTE:** During the initial loading of the auger tube, it will take approximately 5 minutes for the pellets to move from the pellet hopper to the fire pot.

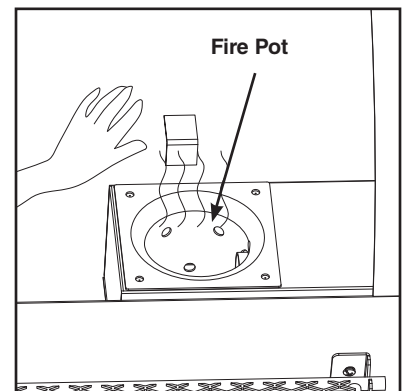

- Step 8** When the pellets start falling into the fire pot, turn the temperature control knob to “OFF”
- Step 9** Replace heat baffle, grease tray and cooking grills into the cooking chamber.
- Step 10** Keep the cooking chamber lid open. Turn temperature control knob to “SMOKE”. You should see smoke coming out of the cooking chamber as the pellets ignite in about 2 minutes.

- Step 11** Close cooking chamber lid and set the temperature control knob to the desired setting. See note below for curing process.

NOTE: Curing the grill is highly recommended before first use. Close cooking chamber lid and set temperature control knob to “HIGH” and allow grill to cure for 45 minutes. This will burn off any oil or paint residue inside the cooking chamber before cooking for the first time.

SUBSEQUENT LIGHTING INSTRUCTIONS:

- Step 1** Open pellet hopper lid and check the pellet level. Add more pellets if necessary.
- ⚠ WARNING:** NEVER add cooking pellets to a hot fire pot by hand. You could be seriously burned.

Step 2 Open cooking chamber lid and turn temperature control knob to “SMOKE”. You should see smoke coming out of the cooking chamber as the pellets ignite in about 2 minutes.

NOTE: Always start the grill on “SMOKE” setting with the cooking chamber lid open.

Step 3 Close cooking chamber lid and set the temperature control knob to the desired setting. For best results, preheat the grill for 10 to 15 minutes with the lid closed before placing food in the grill.

Follow these steps if the grill does not ignite or if the fire in the fire pot goes out while cooking:

Step 1 Turn the temperature control knob to “OFF” and unplug. Open cooking chamber lid and remove all food, cooking grills, grease tray and heat distribution plate.

⚠ CAUTION: Some parts may contain sharp edges. Wear protective gloves if necessary.

⚠ WARNING: Always use oven mitts/gloves to protect your hands. Metal parts become hot during use. Use extreme caution when handling cooking grills, grease tray and baffle.

Step 2 Remove all unburned pellets and ash from inside and around the fire pot.

Step 3 Restart the grill and check that the ignition cycle is working. The heating element should turn red after 1-2 minutes and pellets should be falling into the fire pot from the auger tube.

Step 4 Wearing oven mitts/gloves, replace the baffle, grease tray and cooking grills.

Step 5 Preheat the grill for 10 to 15 minutes with the lid closed before placing food back in the grill. If this procedure is not successful, see Trouble Shooting section in your owner’s manual.

TURNING OFF THE GRILL:

- Turn the temperature control knob to “OFF”. An auto cool down feature will keep the fan running for several minutes.
- Unplug the power cord from the wall outlet.

⚠ WARNING: NEVER add cooking pellets to a hot fire pot by hand. You could be seriously burned. If the hopper runs out of pellets or your fire goes out while cooking, let the grill completely cool and follow the Initial Lighting Instructions.

COOKING:

- Set temperature controller to desired level and allow temperature to be reached.
- Place food on cooking grill.
- With lid open or closed, cook until desired internal temperature is reached.
- Use caution when removing food from Pellet Fuel Grill. All surfaces are HOT and may cause burns. Use protective gloves or long, sturdy cooking tools to remove food.
- Pellet Fuel Grill is HOT while in use and will remain HOT for a period of time afterwards. Use caution.

OPERATING TIPS:

- Your Even Embers Pellet Smoker & Grill® should never be moved while it is hot. If you are transporting your grill in a vehicle after cooking on it, make sure the fire is completely out and the grill is cold before placing it in any vehicle. NEVER put water into the fire pot. It will jam the auger.
- The Even Embers Pellet Smoker & Grill® is designed to operate with the lid closed. Cooking with the lid open greatly lengthens your cooking time.
- Make sure the heat baffle is properly seated on its locating brackets. The long legs of the heat baffle should be pointing down over the fire pot. If not seated properly, direct heat and flame could come up out of the fire pot and cause a grease fire in the grill.
- Smoke stack cap can be adjusted up or down to provide additional temperature and smoke control.

SMOKE MODE:

- The “SMOKE” settings is for smoking and adding smoke flavor to foods being cooked.
- Smoke Mode can be adjusted from P0 to P4. P0 provides less smoke into the cooking chamber and can be adjusted up to P4 for maximum smoke. P2 is the normal factory setting.
- Adjusting the smoke mode to a higher setting will cause more fluctuation in the temperature of the cooking chamber.
- Turn the temperature control knob to smoke. To adjust the P setting press the “P” set button to change the P setting.

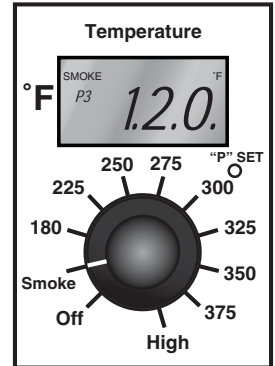

COOK MODE:

- The temperature dial can be changed at any time to increase or decrease the cooking temperature of the grill.
 - The 325°F to “HIGH” temperature settings are for grilling.
 - The 180°F to 300°F temperature settings are for slow cooking.
- Adjust the control knob to a desired temperature. The selected temperature will be in the bottom left hand corner of the digital display.
- Adjusting the smoke mode to a higher setting will cause more fluctuation in the temperature of the cooking chamber.

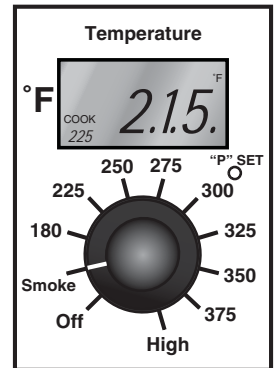

ERROR CODES:

- “8.8.8.” – Display will flash for 1-2 seconds when first plugged into power outlet. This is normal, not an indication of a problem.
- “ErP” – Error Power will occur when grill is plugged into power outlet and the temperature control knob is not in “OFF” position.
- “. . .” – Flashing Dots indicate that the igniter is “ON”. The igniter will stay on for 5 minutes and then go off.
- “ErH” – High Temp Limit indicates that the temperature in the cooking chamber has exceeded 565°F.
- “Err” – Thermocouple may be unhooked or damaged.



PROPER CARE & MAINTENANCE:

- Remove wood pellets from hopper if grill will not be used for a long period of time. Wood pellets can become soggy due to moisture/humidity and can cause the auger to bind up or not push pellets to burn chamber.
- Disposal of ashes – Ashes should be placed in a metal container with a tight-fitting lid. The closed container of ashes should be placed on a non-combustible floor or on the ground, well away from all combustible materials, pending final disposal. When the ashes are disposed by burial in soil or otherwise locally dispersed, they should be retained in the closed container until all cinders have thoroughly cooled.
- To protect your grill from excessive rust, the unit must be kept clean and covered at all times when not in use.
- Wash cooking grills and heat distribution plate with hot, soapy water, rinse well and dry. Lightly coat cooking grill with vegetable oil or vegetable oil spray.
- Clean inside and outside of grill by wiping off with a damp cloth. Apply a light coat of vegetable oil or vegetable oil spray to the interior surface to prevent rusting.
- Never apply paint to the interior surface. Rust spots on the interior surface can be buffed, cleaned, the lightly coated with vegetable oil or vegetable oil spray to minimize rusting.
- Depending on use, periodically remove the cooking grills, grease tray and heat distribution plate to clean the ash from in and around the fire pot. A shop-vac is handy for this chore. Make sure the grill is cold before starting this procedure.

HELPFUL HINTS:

- If you pre-cook meat or poultry, do so immediately before grilling.
- Never defrost meat at room temperature or on a counter top.
- Refrigerate leftovers within 2 hours of taking food off the grill.
- For additional information, please phone the USDA's toll free Meat & Poultry Hotline at 800-535-4555.

CLEANING AND MAINTENANCE:

- Keep the appliance free and clear of combustible materials, gasoline and other flammable vapors and liquids.
- For safe grilling and peak performance of your grill, perform these checks at least twice per year or after extended periods of storage.
- Be sure to tighten up all hardware (nuts, bolts, screws, etc.) at least twice per year.
CAUTION: Some parts may contain sharp edges. Wear protective gloves if necessary.
- Remove the cooking grills, from inside your grill. Use a brush with hot water and detergent to remove excess residue. NEVER use a commercial oven cleaner. Rinse completely with water. Towel dry and replace all components as described in the assembly instructions.

COOKING GRILLS:

- Clean with mild soap detergent and water. Use a grill cooking grate brush to remove residue from the porcelain coated surfaces. The steel wire can cause the finish to chip or crack. DO NOT use a commercial oven cleaner.

TRANSPORTING AND STORAGE:

WARNING

- **Never move a grill when it is hot or when objects are on the cooking surfaces.**
- **Never store flammable liquids or spray canisters under or near the grill.**
- **DO NOT extinguish grease fires using water.**

BEFORE STORING YOUR GRILL:

- Clean all surfaces.
- If storing the grill outdoors, close the wood pellet lid and cover the grill with a grill cover for protection from the weather.
- If the grill is stored outside during the rainy season, care should be taken to ensure that water does not get into the pellet hopper. Wood pellets, when wet, expand greatly and will jam your auger.

GRILL COOKING TIPS:

CLEANLINESS:

- Always wash hands thoroughly with soap and hot water prior to handling food and after handling raw meat, uncooked poultry or seafood.
- When using a platter to carry raw meat, uncooked poultry or seafood to the grill, make sure to wash the platter thoroughly with soap and hot water before placing cooked foods back on the platter or use different platters for raw and cooked foods.
- Never use the same utensils when handling raw meat, uncooked poultry or seafood unless you wash the utensils thoroughly with soap and hot water.
- Never re-use marinade from raw meat or uncooked poultry on foods that have been cooked and are ready to be served.

GRILLING TO PROPER TEMPERATURE:

- Use a meat thermometer to be sure food has reached a safe internal temperature.
- The US Department of Agriculture recommends the minimum temperature be reached for the following food items:

Chops	145 degrees F (62.8° C)
Ground Meat	160 degrees F (71° C)
Pork	145 degrees F (62.8° C)
Poultry	165 degrees F (73.9° C)
Roasts	145 degrees F (62.8° C)
Seafood	145 degrees F (62.8° C)
Vegetables	145 degrees F (62.8° C)

TROUBLE SHOOTING:

PROBLEM	CAUSE	CORRECTION
Electric element will not heat up	<ol style="list-style-type: none"> 1. Check that the 3-wire plug is fully seated into a 3-wire grounded GFCI outlet wired for 120 volts. 2. Check the breakers or fuses for the outlet being used are not open or blown. 3. Check that the GFCI outlet has not been tripped. 4. Electric element only heats up (becomes red) during the first 5 minutes after power switch is turned on. 5. Fuse-Blown. 	<ol style="list-style-type: none"> 1. Reseat plug in a 3-wire grounded GFCI outlet wired for 120 volts. 2. Reset breakers or replace fuse. 3. Reset GFCI outlet. 4. Turn Power switch "Off" then "Smoke" again. 5. Replace max fuse size: 5mm x 20 mm, 5 amps.
Grill is not getting hot enough	<ol style="list-style-type: none"> 1. Adjust temperature control on temperature controller. 2. Avoid the temptation to check food too often. 3. Verify that there are pellets in pellet hopper. 4. Fire goes out on "SMOKE" setting. 	<ol style="list-style-type: none"> 1. Turn up heat on control dial. 2. Opening the door allows heat to escape and slows the cooking process; open door only when necessary. 3. Add pellets and allow sufficient time for the pellets to travel from the pellet hopper to the fire pot (can take up to 7 minutes). 4. Excess ash. IMPORTANT: Remove all unburned pellets and ash from inside and around the fire pot. A shop-vac is ideal for the task CAUTION! ASSURE THAT THE GRILL IS COLD TO AVOID A FIRE FROM HOT ASH.
Grill is getting too hot	<ol style="list-style-type: none"> 1. Adjust temperature control. 	<ol style="list-style-type: none"> 1. Turn down heat on temperature control dial.
Smoke comes out of smoker box	<ol style="list-style-type: none"> 1. This is normal due to the air pressure inside the smoker. The amount of smoke can vary depending on cooking conditions. 	<ol style="list-style-type: none"> 1. This condition will not affect cooking.
Temperature or digital display does not match "set" temperature	<ol style="list-style-type: none"> 1. When first lighting smoker, it takes 15 minutes or so for temperature to stabilize. 2. When adjusting temperature, it takes 15 minutes or so for temperature to stabilize. 	<ol style="list-style-type: none"> 1. Wait 15 minutes or so for temperature to stabilize.

WIRING DIAGRAM:

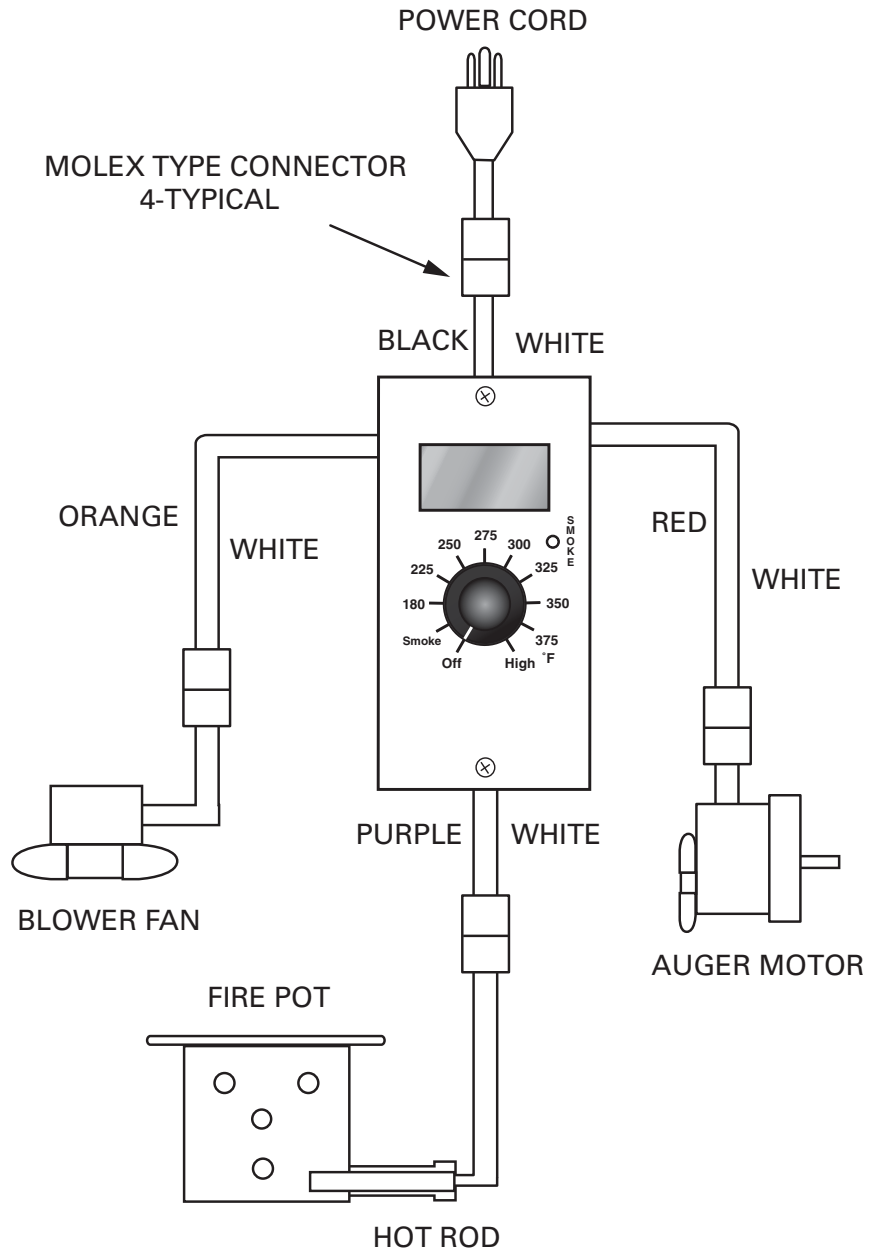

NOTE: FUSE IS LOCATED ON BACK OF CONTROL.
Maximum Fuse Size: 5mm x 20 mm, 5 amps

ASSEMBLY INSTRUCTIONS:

Make sure you have all items listed under PARTS LIST and PARTS CARD CONTENTS before you begin the installation process.

PARTS CARD CONTAINS:

- (2) M4 x 10mm Bolts & M4 Nuts
- (2) M12 Wheel Nuts
- (2) M12 Wheel Washers
- (32) M6 Nuts
- (44) M6 x 12mm Bolts
- (20) M6 Lock Washers

M4 x 10mm Bolts &
M4 Nuts - 2pcs

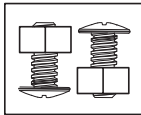

Wheel Washers - 2pcs

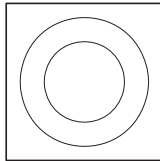

M12 Wheel Nuts - 2pcs

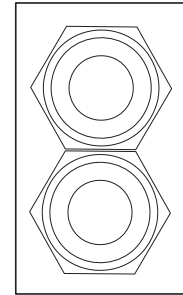

M6 Lock Washers - 20pcs
Cart Base and Legs

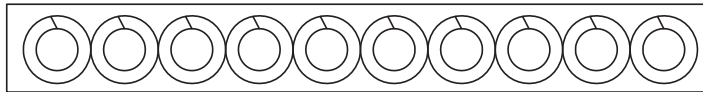

M6 Nuts - 32pcs

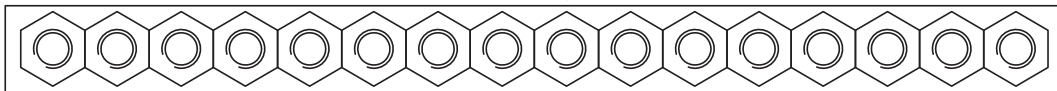

M6 x 12mm Bolts - 22pcs

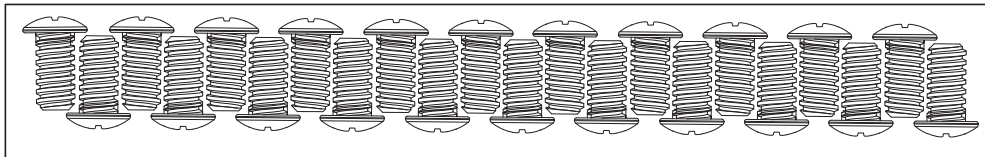

M6 x 12mm Bolts - 22pcs

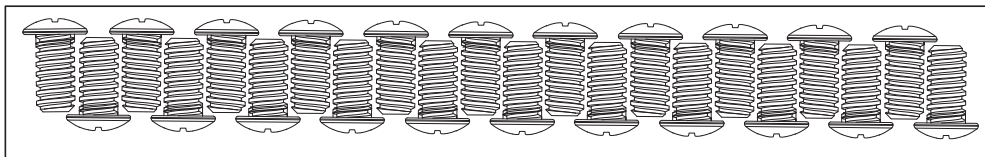

**⚠ READ ALL SAFETY WARNINGS & INSTRUCTIONS CAREFULLY
BEFORE ASSEMBLING AND OPERATING YOUR EVEN EMBERS® PELLET SMOKER & GRILL.**

*FOR MISSING PARTS, PLEASE CALL CUSTOMER SERVICE AT 855-735-9922.
(Proof of purchase will be required.)*

The following tools are required to assemble your Even Embers® Pellet Smoker & Grill:

- **Phillips Screwdriver**
- **Wrench**

PARTS LIST:

- | | | | |
|---|-------------------------------|---|--------------------------------|
| ① | 1 Warming Rack | ⑭ | 1 Grease Bucket |
| ② | 2 Cooking Grates | ⑮ | 1 Left Rear Leg |
| ③ | 1 Grease Tray | ⑯ | 1 Left Front Leg |
| ④ | 1 Right Side Mounting Bracket | ⑰ | 1 Right Rear Leg |
| ⑤ | 1 Grease Drainage Tray | ⑱ | 1 Right Front Leg |
| ⑥ | 2 Warming Rack Brackets | ⑲ | 2 Front Shelf Mounting Bracket |
| ⑦ | 1 Heat Baffle | ⑳ | 1 Front Shelf |
| ⑧ | 1 Chimney Cap | ㉑ | 1 Bottom Shelf |
| ⑨ | 1 Chimney | ㉒ | 1 Leg Bracket |
| ⑩ | 1 Temperature Gauge | ㉓ | 2 Wheels |
| ⑪ | 1 Grill Body Assembly | ㉔ | 1 Wheel Axle |
| ⑫ | 1 Side Handle | ㉕ | 1 Chimney Gasket |
| ⑬ | 1 Pellet Hopper Assembly | ㉖ | 1 Pellet Hopper Gasket |

FOR COVERS, ACCESSORIES AND OTHER PRODUCTS, PLEASE VISIT US ONLINE AT:

www.evenembers.com

Inspect contents of the box to ensure all parts are included and undamaged.

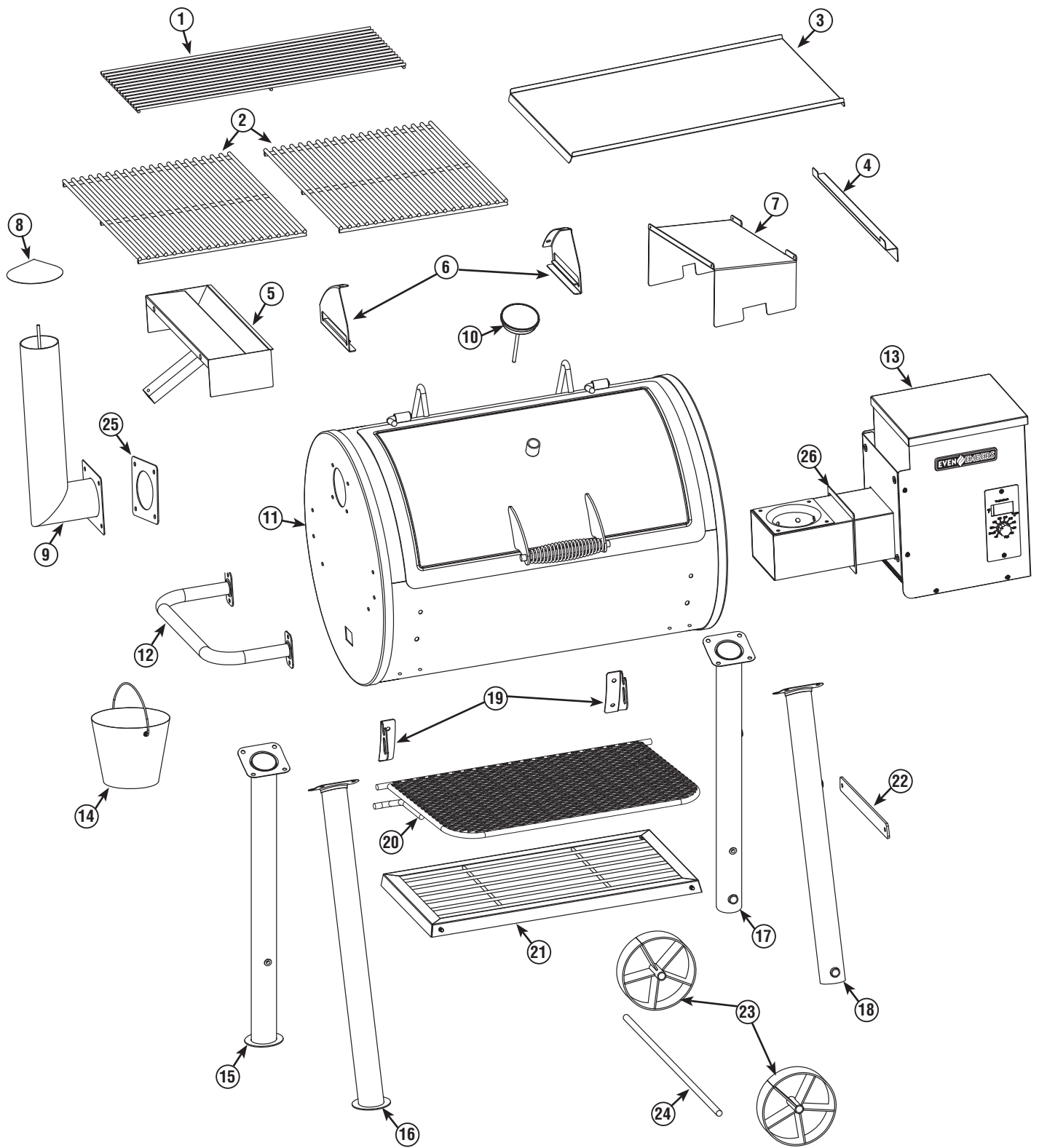

1

Place grill body on its end with the lid open as illustrated.

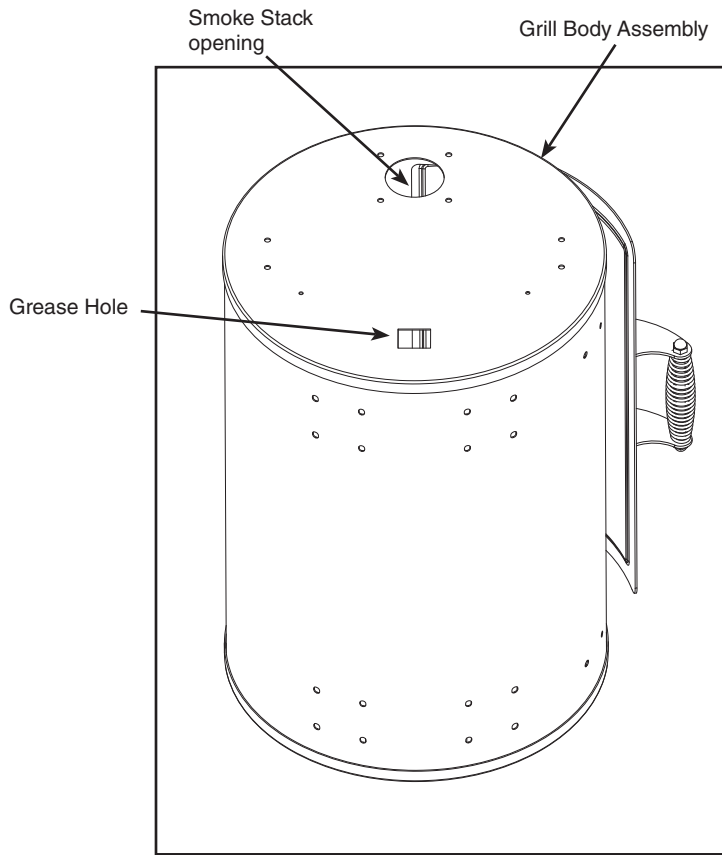

2

TOP VIEW

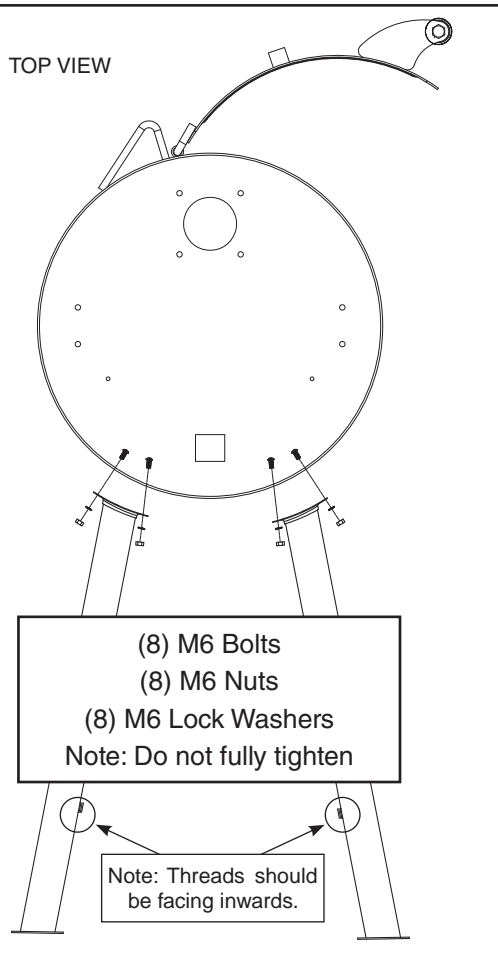

3

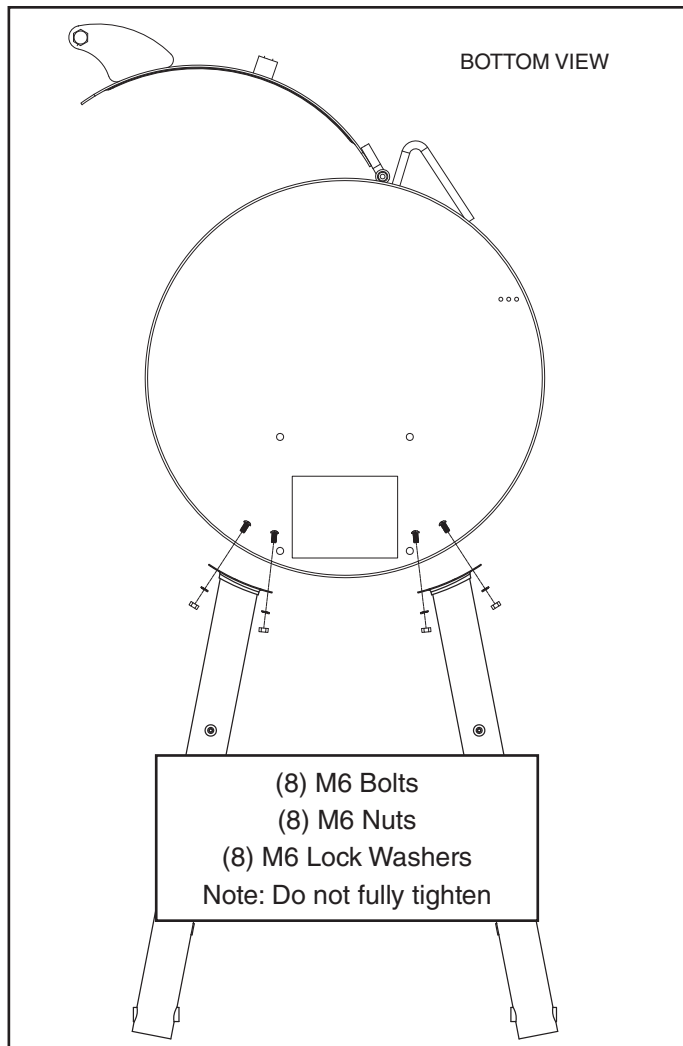

4

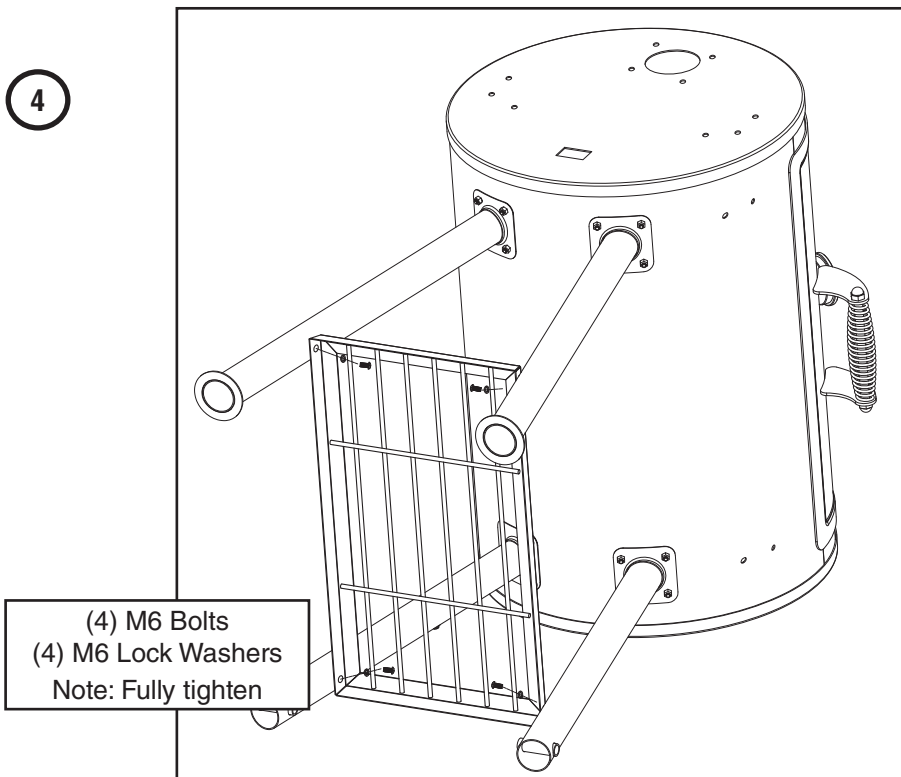

5

(2) M12 Wheel Washers
(2) M12 Nuts

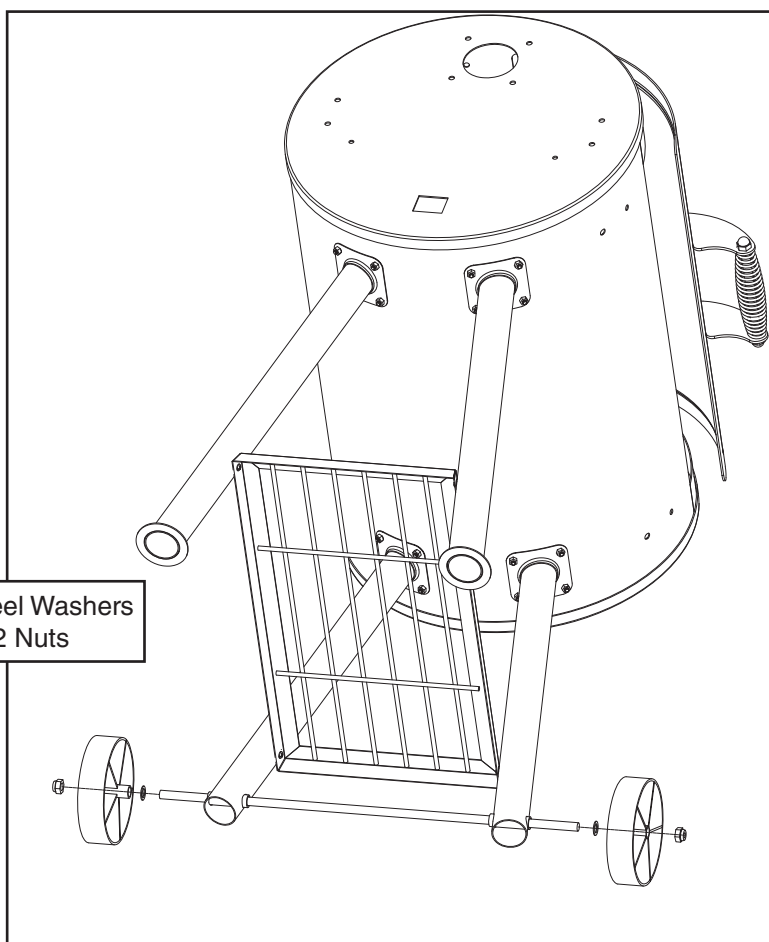

6

(2) M6 Bolts
Note: Do not fully tighten

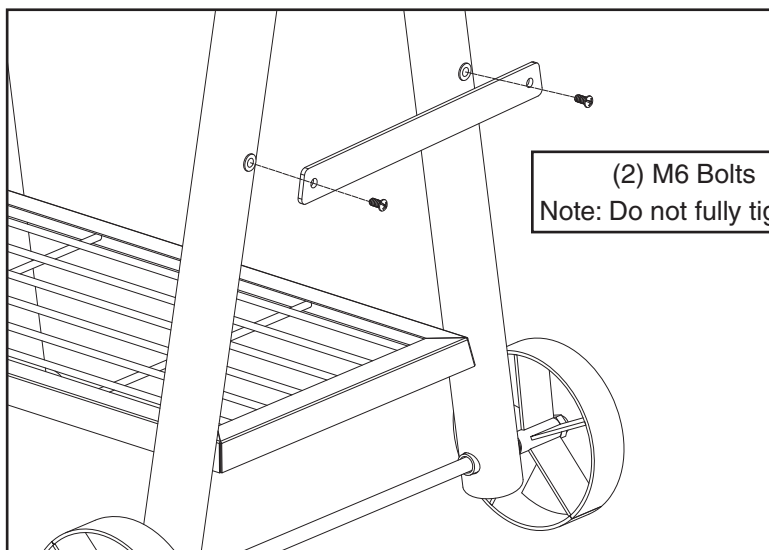

7

Once you have followed steps 1-6, turn the smoker upright and make sure it's on level ground. Tighten all bolts.

8

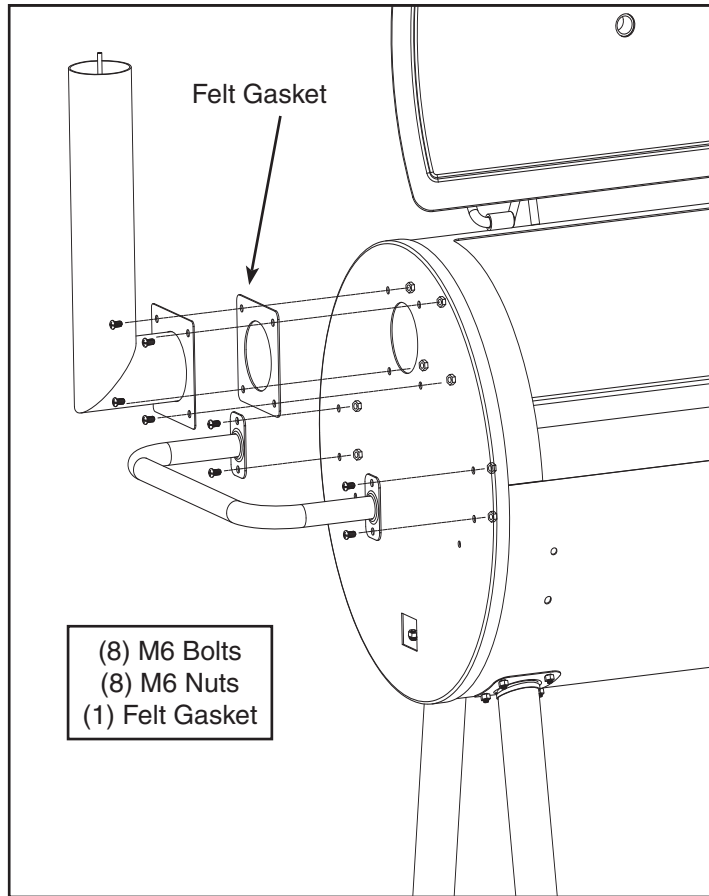

9

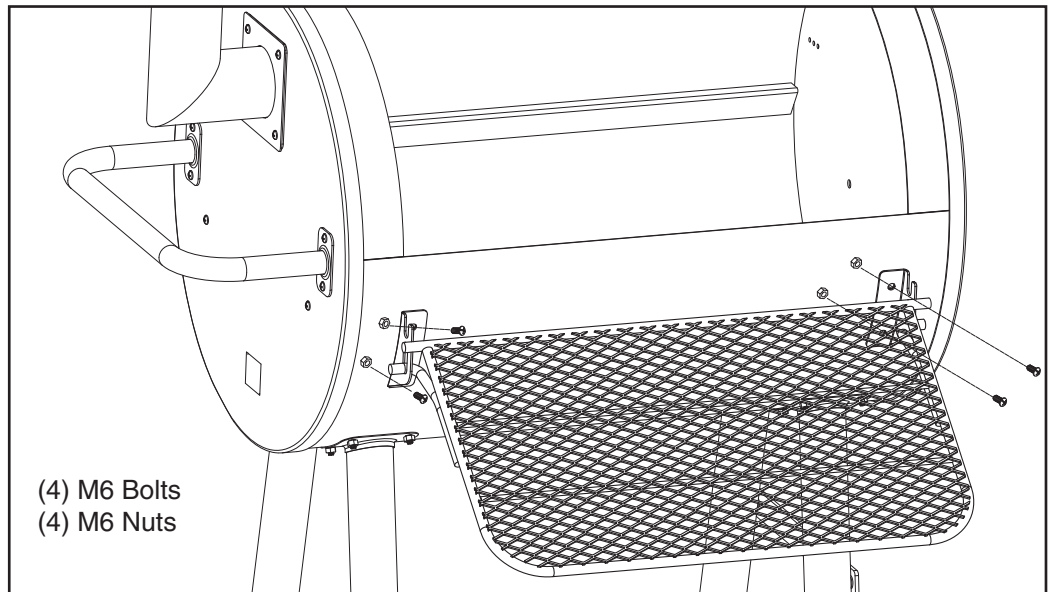

10

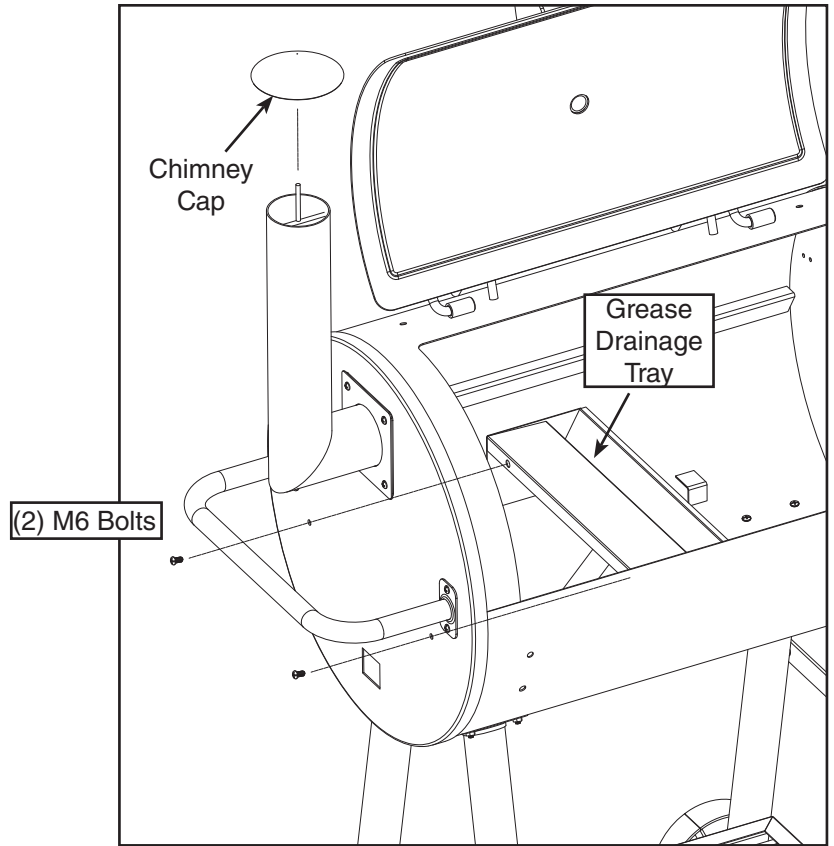

11

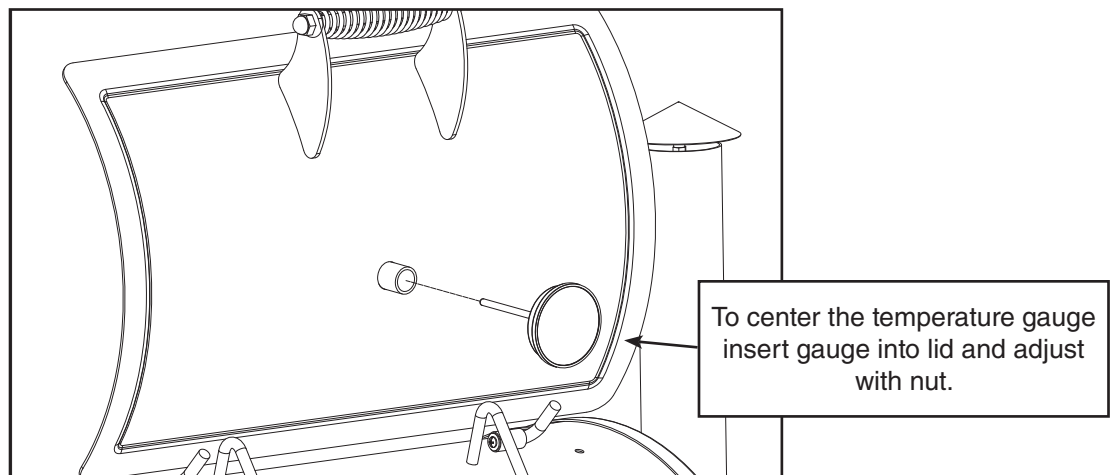

12

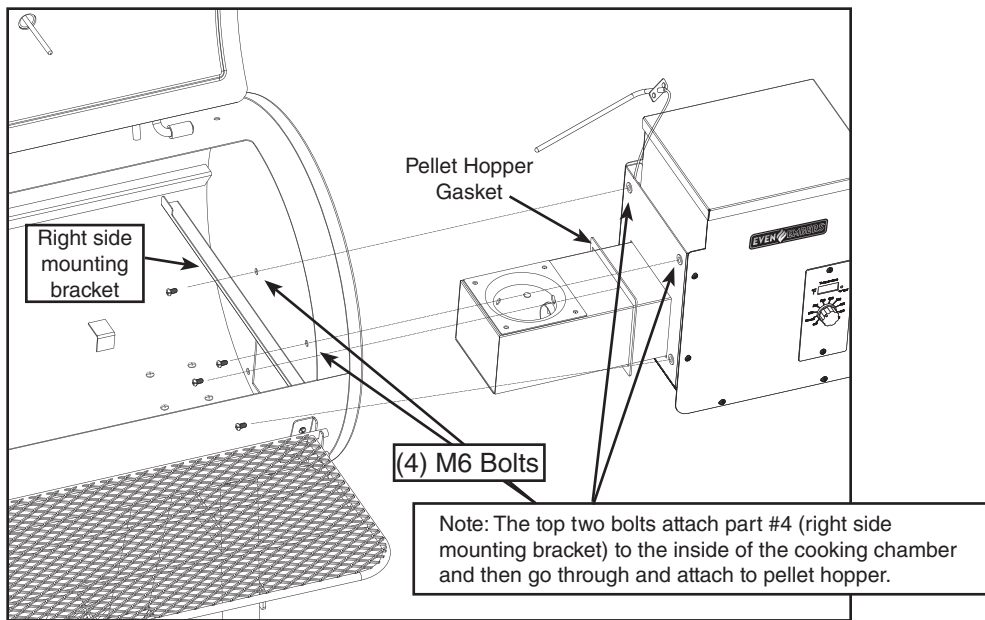

13

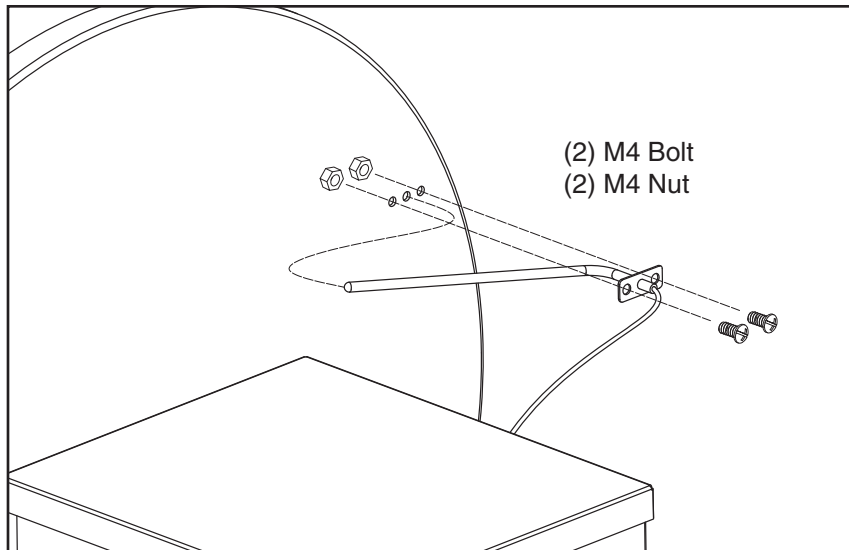

14

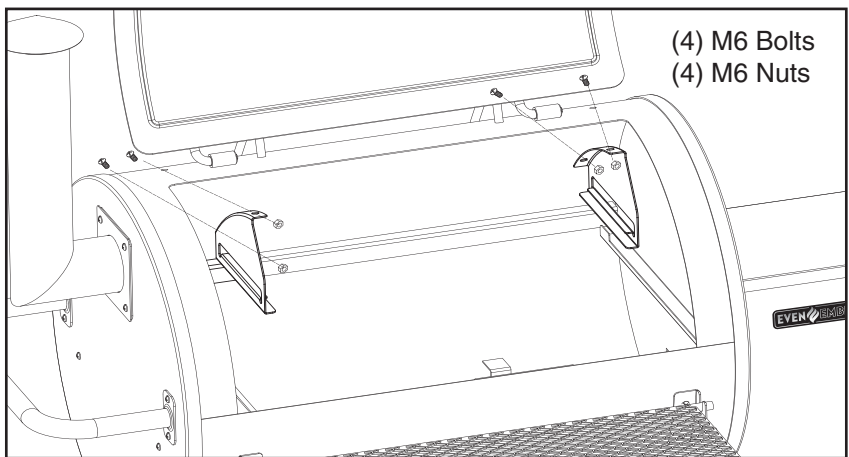

15

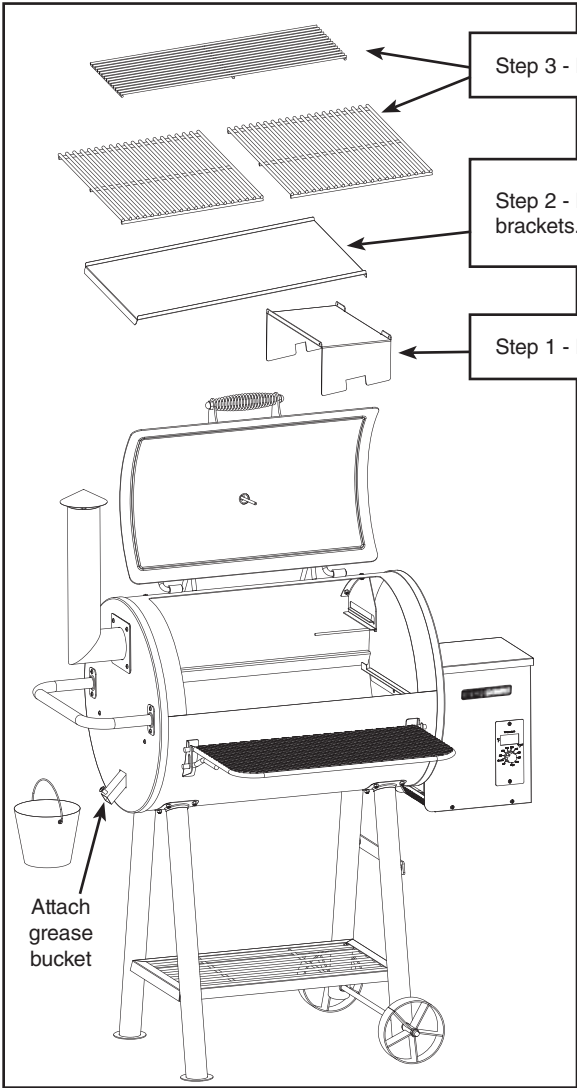

Step 3 - Install cooking grates and warming rack.

Step 2 - Install the grease tray so that it sits on the left and right mounting brackets.

Step 1 - Install heat baffle onto brackets so it sits over fire pot.

Attach grease bucket

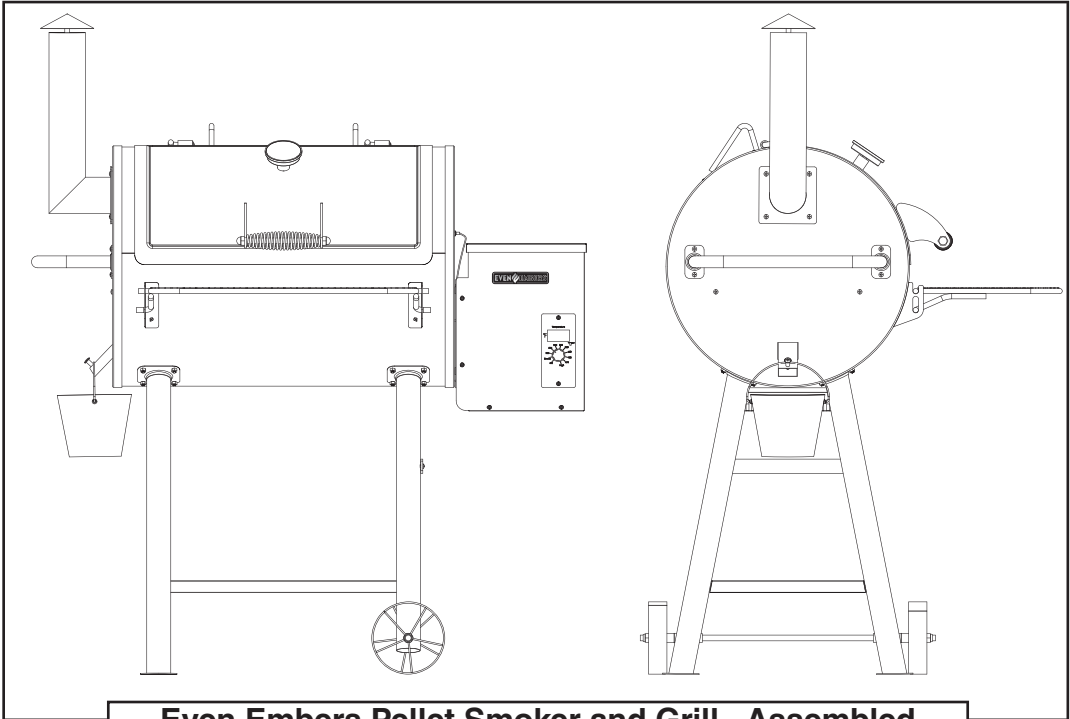

Even Embers Pellet Smoker and Grill - Assembled

WARRANTY

Embers Grills warrants to the original purchaser that the Even Embers® Pellet Fuel Grill is free from defects due to workmanship or materials for: One-year: frame, housing, cart, cooking grates, electric heating elements, temperature controller and other related parts

Embers Grills obligations under this warranty are limited to the following guidelines:

- This warranty does not cover grills that have been altered/modified or damaged due to: normal wear, rust, abuse, improper maintenance and/or improper use.
- This warranty does not cover surface scratches, rust or heat damage to the finish, which is considered normal wear.
- Embers Grills may elect to repair or replace damaged units covered by the terms of this warranty.
- This warranty extends to the original purchaser only and is not transferable or assignable to subsequent purchasers.

Embers Grills requires reasonable proof of purchase. Therefore, we strongly recommend that you retain your sales receipt or invoice. To obtain replacement parts for your Even Embers® Pellet Fuel Grill under the terms of this warranty, please call Customer Service Department at 1-855-735-9922. A receipt will be required. Embers Grills will not be responsible for any grills forwarded to us without prior authorization.

EXCEPT AS ABOVE STATED, THE EMBERS GRILLS MAKES NO OTHER EXPRESS WARRANTY. THE IMPLIED WARRANTIES OF MERCHANTABILITY AND FITNESS FOR A PARTICULAR PURPOSE ARE LIMITED IN DURATION TO THOSE LISTED ABOVE FROM THE DATE OF PURCHASE. SOME STATES DO NOT ALLOW LIMITATIONS ON HOW LONG AN IMPLIED WARRANTY LASTS, SO THE ABOVE LIMITATION MAY NOT APPLY TO YOU. ANY LIABILITY FOR INDIRECT, INCIDENTAL OR CONSEQUENTIAL DAMAGES ARISING FROM THE FAILURE OF THE EVEN EMBERS® PELLETT FUEL GRILL TO COMPLY WITH THIS WARRANTY OR ANY IMPLIED WARRANTY IS EXCLUDED. CUSTOMER ACKNOWLEDGES THAT THE PURCHASE PRICE CHARGED IS BASED UPON THE LIMITATIONS CONTAINED IN THE WARRANTY SET OUT ABOVE. SOME STATES DO NOT ALLOW THE EXCLUSION OR LIMITATION OF INCIDENTAL OR CONSEQUENTIAL DAMAGES, SO THE ABOVE LIMITATION OR EXCLUSION MAY NOT APPLY TO YOU. THIS WARRANTY GIVES YOU SPECIFIC LEGAL RIGHTS, AND YOU MAY ALSO HAVE OTHER RIGHTS WHICH VARY FROM STATE TO STATE.