



P4

FREE-STANDING PELLET STOVE

OWNER'S MANUAL

WARRANTY REGISTRATION
enviro.com/warranty



PLEASE READ THIS ENTIRE MANUAL BEFORE INSTALLATION AND USE OF THIS PELLET BURNING ROOM HEATER. FAILURE TO FOLLOW THESE INSTRUCTIONS COULD RESULT IN PROPERTY DAMAGE, BODILY INJURY OR EVEN DEATH

CONTACT YOUR BUILDING OR FIRE OFFICIALS ABOUT RESTRICTIONS AND INSTALLATION INSPECTION REQUIREMENTS IN YOUR AREA.

TABLE OF CONTENTS

Introduction.....	3
Important Safety Data.....	3
Emissions and Efficiencies.....	4
Safety Warnings And Recommendations.....	5
Rating Label Location.....	7
Pellet Quality.....	7
Installation.....	8
Deciding Where to Locate the Appliance.....	8
Unpacking and Removing Pellet Stove From Pallet.....	8
Clearances to Combustibles.....	10
Alcove Clearances.....	10
Vent Termination Requirements.....	11
Outside Fresh Air Connection.....	12
Exhaust and Intake Locations.....	12
Mobile Home Installation.....	13
Corner Through Wall Installation.....	13
Horizontal Exhaust Through Wall Installation.....	14
Through Wall Vertical Rise Horizontal Termination - Freestanding.....	15
Inside Vertical Installations.....	16
Outside Vertical Installations.....	16
Hearth Mount Installation.....	17
Thermostat Installation.....	18
Specifications.....	19
Dimensions and Specifications.....	19
Operating Instructions.....	20
Control Board Functions.....	20
Automatic Safety Features of Your Pellet Stove.....	20
Operating Your Pellet Stove.....	21
Turning Your Pellet Stove Off.....	21
Damper Set-Up.....	21
Guidelines For Fine-Tuning For Fuel Quality.....	22
Routine Cleaning and Maintenance.....	23
Troubleshooting.....	27
Wiring Diagram.....	30
Parts List.....	31
Parts Diagram.....	33
Rating Label.....	35
Warranty.....	36
Installation Data Sheet.....	37
Notes.....	38

INTRODUCTION

IMPORTANT SAFETY DATA:

Please read this entire Owner's Manual before installing or operating your ENVIRO Pellet Stove. Failure to follow these instructions may result in property damage, bodily injury or even death. Any unauthorized modification of the appliance or use of replacement parts not recommended by the manufacturer is prohibited.

Contact your local building or fire official to obtain a permit and any information on installation restrictions and inspection requirements for your area. All local regulations, including those referring to national and European Standards need to be complied with when installing this appliance.

To prevent the possibility of a fire, ensure that the appliance is properly installed by adhering to the installation instructions. An ENVIRO dealer will be happy to assist you in obtaining information with regards to your local building codes and installation restrictions.

The stove's exhaust system works with negative combustion chamber pressure and a slightly positive chimney pressure. It is very important to ensure that the exhaust system be sealed and airtight. The ash pan and viewing door must be locked securely for proper and safe operation of the pellet stove. Operating with door open could cause a fire inside the house as well as the release of carbon monoxide into the living space.

Carbon monoxide is a colorless and odorless gas, to prevent it from poisoning you or your family know the symptoms of carbon monoxide poisoning: headache, dizziness, weakness, sleepiness, nausea, vomiting, and confusion. Carbon monoxide reduces the blood's ability to carry oxygen. Low blood oxygen levels can result in loss of consciousness and death.

Do not burn with insufficient combustion air. A periodic check is recommended to ensure proper combustion air is admitted to the combustion chamber. Setting the proper combustion air is achieved by adjusting the slider damper located on the left side of the stove.

When installing the stove in a mobile home, it must be electrically grounded to the steel chassis of the home and bolted to the floor. Make sure that the structural integrity of the home is maintained and all construction meets local building codes.

Consider all large air moving devices when installing your unit and provide room air accordingly. NOTE: Extractor fans when operating in the same room or space as the appliance, may cause problems. Limited air for combustion may result in poor performance, smoking and other side effects of poor combustion.

Soot or creosote may accumulate when the stove is operated under incorrect conditions such as an extremely rich burn (black tipped, lazy orange flames).

Be sure to maintain the structural integrity of your home when passing a vent through walls, ceilings, or roofs. It is recommended that the unit be secured into its position in order to avoid any displacement. This appliance must be installed on a floor with an adequate load bearing capacity. If an existing construction doesn't meet these prerequisite, suitable measures (e.g. load distributing plate) shall be taken to achieve it.

FRESH AIR: Outside Fresh Air connection is optional. Fresh Air must be connected to all units installed in Mobile Homes and Air Tight Homes (R2000) or where required by local codes.

If you have any questions with regards to your stove or the above-mentioned information, please feel free to contact your local dealer for further clarification and comments.

INTRODUCTION

EMISSIONS AND EFFICIENCY - EVOLUTION:

Rates: This manual describes the installation and operation of the Enviro P4 Pellet heater. This heater meets the 2015 U.S. Environmental Protection Agency's pellet emission limits for pellet emission limits sold after May 15, 2015. Under specific test conditions this heater has been shown to deliver heat at rates ranging from 8,200-23,000 Btu/hr.

WARNING: This pellet heater needs periodic inspection and repair for proper operation. It is against federal regulations to operate this pellet heater in a manner inconsistent with operating instructions in this manual.

WARNING: This pellet heater has a manufacturer set minimum low burn rate that must not be altered. It is against federal regulations to alter this setting or otherwise operate this pellet heater in a manner inconsistent with operating instructions in this manual.

INTRODUCTION

SAFETY WARNINGS AND RECOMMENDATIONS:

Caution: Do not connect to any air distribution duct or system. Do not burn garbage or flammable fluids such as gasoline, naphtha or engine oil. Unit hot while in operation. Keep children, clothing and furniture away. Contact may cause skin burns.

Warning: Parts of the appliance, especially the external surfaces, will be hot to touch when in operation and due care will need to be taken. Never place wood, paper, furniture, drapes or other combustible materials within 80cm (31½") of the front of the unit, 20cm (7⅞") from each side, and 10cm (4") from the back of the unit. Do not let children or pets touch it when it is hot.

To prevent the possibility of a fire, ensure that the appliance is properly installed by adhering to the installation instructions. An ENVIRO dealer will be happy to assist you in obtaining information with regards to your local building codes and installation restrictions.

FIRE EXTINGUISHER AND SMOKE DETECTION: All homes with a pellet burning stove should have at least one fire extinguisher in a central location known to all in the household. Smoke detectors and carbon monoxide detectors should be installed and maintained in the room containing the stove. If it sounds the alarm, correct the cause but do not deactivate. You may choose to relocate the smoke detection device within the room; **DO NOT REMOVE THE SMOKE OR CARBON MONOXIDE DETECTORS FROM THE ROOM.**

CHIMNEY OR RUN AWAY FIRE: Call local fire department (or dial 911). Close the draft fully. Examine the flue pipes, chimney, attic, and roof of the house, to see if any part has become hot enough to catch fire. If necessary, spray with fire extinguisher or water from the garden hose. **IMPORTANT:** Do not operate the stove again until you are certain the chimney and its lining have not been damaged.

FUEL: This pellet stove is designed and approved to only burn wood pellet fuel with up to 3% ash content. Dirty fuel will adversely affect the operation and performance of the unit and may void the warranty. Check with your dealer for fuel recommendations.

THE USE OF CORD WOOD IS PROHIBITED BY LAW.

SOOT and FLYASH: Formation and Need for Removal - The products of combustion will contain small particles of flyash. The flyash will collect in the exhaust venting system and restrict the flow of flue gases. Incomplete combustion, such as occurs during startup, shutdown, or incorrect operation of the room heater will lead to some soot formation which will collect in the exhaust venting system. The exhaust venting system should be inspected at least once every year to determine if cleaning is necessary.

CREOSOTE: When wood is slowly burned it produces tar and other organic vapours and these combine with expelled moisture to form creosote. The creosote vapours condense in the relatively cool chimney flue associated with a slow burning fire. As a result, creosote residue accumulates on the flue lining. When ignited this creosote can result in an extremely hot chimney fire.

CLEANING: There will be some build up of fly ash and small amounts of creosote in the exhaust. This will vary due to the ash content of the fuel used and the operation of the stove. It is advisable to inspect and clean the exhaust vent semi-annually or every two tons of pellets.

ASHES: Disposed ashes should be placed in a metal container with a tight fitting lid. The closed container of ashes should be on a non-combustible floor on the ground, well away from all combustible materials pending final disposal. If the ashes are disposed of by burial in soil or otherwise locally dispensed, they should be retained in the closed container until all cinders have been thoroughly cooled.

INTRODUCTION

ELECTRICAL: The use of a surge protected power bar is recommended. The unit must be grounded. The grounded electrical cord should be connected to a standard 110-120 volts, nominal average 2.0 Amps (4.1 Amps peak), 60 hertz electrical outlet and also must be accessible. Ensure the polarity to the outlet the unit will be plugged into is correct as incorrect polarity can affect the unit's operation. If this power cord should become damaged, a replacement power cord must be purchased from the manufacturer or a qualified ENVIRO dealer. Be careful that the electrical cord is not trapped under the appliance and that it is clear of any hot surfaces or sharp edges. This unit's maximum power requirement is 184 watts (600 watts peak).

GLASS: Do not abuse the glass by striking or slamming the door. Do not attempt to operate the stove with broken glass. The stove uses ceramic glass. Replacement glass must be purchased from an ENVIRO dealer. Do not attempt to open the door and clean the glass while the unit is in operation or if glass is hot. To clean the glass, use a soft cotton cloth and mild window cleaner, gas or wood stove glass cleaner, or take a damp paper towel and dip into the fly ash. This is a very mild abrasive and will not damage the glass.

FLAMMABLE LIQUIDS: Never use gasoline, gasoline-type lantern fuel, kerosene, charcoal lighter fluid, or similar liquids to start or "freshen up" a fire in the heater. Keep all such liquids well away from the heater while it is in use.

SMOKE DETECTOR: Smoke detectors should be installed and maintained in the structure when installing and operating a pellet burning appliance.

OPERATION: The ash pan and door must be closed securely for proper and safe operation of the pellet stove. Also ensure all gaskets on the door are checked and replaced when necessary.

KEEP ASH PAN FREE OF RAW FUEL.

Do not place unburned fuel or new fuel in ash pan. A fire in the ash pan may occur.

INSTALLATION: Be sure to maintain the structural integrity of your home when passing a vent through walls, ceilings, or roofs. It is recommended that the unit be secured into its position in order to avoid any displacement.

DO NOT INSTALL A FLUE DAMPER IN THE EXHAUST VENTING SYSTEM OF THIS UNIT.

DO NOT CONNECT THIS UNIT TO A CHIMNEY FLUE SERVING ANOTHER APPLIANCE.

FRESH AIR: Outside Fresh Air connection is optional. Must be connected to all units installed in Mobile and "Air Tight Homes" (R2000) or where required by local codes. Consider all large air moving devices when installing your unit and provide fresh air accordingly. Limited air for combustion may result in poor performance, smoking and other side effects of poor combustion.

If you have any questions with regards to your stove or the above-mentioned information, please feel free to contact your local dealer for further clarification and comments.

SINCE SHERWOOD INDUSTRIES LTD. HAS NO CONTROL OVER THE INSTALLATION OF YOUR STOVE, SHERWOOD INDUSTRIES LTD. GRANTS NO WARRANTY IMPLIED OR STATED FOR THE INSTALLATION OR MAINTENANCE OF YOUR STOVE. THEREFORE, SHERWOOD INDUSTRIES LTD. ASSUMES NO RESPONSIBILITY FOR ANY CONSEQUENTIAL DAMAGE(S).

SAVE THIS INSTRUCTION MANUAL FOR FUTURE REFERENCE

INTRODUCTION

RATING LABEL LOCATION:

The rating label is located on the back of the ash pan access cover.

PELLET QUALITY:

Pellet quality is important, please read the following:

Your Enviro pellet stove has been designed to burn wood pellets only. Do not use any other type of fuel, as this will void any warranties stated in this manual.

The performance of your pellet stove is greatly affected by the type and quality of wood pellets being burned. As the heat output of various quality wood pellets differs, so will the performance and heat output of the pellet stove.

CAUTION: It is important to select and use only pellets that are dry and free of dirt or any impurities such as high salt content. Dirty fuel will adversely affect the operation and performance of the unit and will void the warranty. Pellet Fuel Industries (P. F. I.) has established standards for wood pellet manufacturers. We recommend the use of pellets that meet or exceed these standards. Ask your dealer for a recommended pellet type.

P. F. I. PELLET STANDARDS:

Fines (fine particles).....	1% maximum through a 1/8" screen
Bulk Density.....	40 pound per cubic foot minimum
Size.....	1/4" to 5/16" diameter 1/2 – 1 1/2" long maximum
Ash Content.....	1% maximum (Premium grade)
	3% maximum (Standard grade)
Moisture Content.....	8% maximum
Heat Content.....	approximately 8200 BTU per pound minimum

ASH: The ash content of the fuel and operation of your stove will directly determine the frequency of cleaning. The use of high ash fuels may result in the stove needing to be cleaned daily. A low ash fuel may allow longer intervals between cleaning.

CLINKERING: [clinkers are silica (sand) or other impurities in the fuel that will form a hard mass during the burning process]. This hard mass will block the air flow through the Burn Pot Liner and affect the performance of the stove. Any fuel, even approved types, may tend to clinker. Check the Burn-Pot Liner daily to ensure that the holes are not blocked with clinkers. If they become blocked, remove the liner (when the unit is cold) and clean/scrape the clinkers out. Clean the holes with a small pointed object if required. Refer to the section Routine Cleaning and Maintenance.

PELLET FEED RATES: Due to different fuel densities and sizes, pellet feed rates may vary. This may require an adjustment to the slider damper setting or to the auger feed trim setting on low.

Since Sherwood Industries Ltd. has no control over the quality of pellets that you use, we assume no liability for your choice in wood pellets.

Store pellets in a dry area at least 36" (1 m) away from the pellet stove.

INSTALLATION

DECIDING WHERE TO LOCATE YOUR PELLET APPLIANCE:

1. Check the "Clearances to Combustibles" section for proper spacing.
2. Do not obtain combustion air from an attic, garage or any unventilated space. Combustion air may be obtained from a ventilated crawlspace.
3. Do not install the stove in a bedroom.
4. You can vent the stove through an exterior wall behind the unit or connect it to an existing masonry or metal wood stove chimney (must be lined if the chimney is over 6" (15 cm) diameter, or over 28 inches² (180 cm²) cross sectional area). An interior vent can be used with approved pipe passing through the ceiling and roof.
5. Locate the stove in a large and open room that is centrally located in the house. This will optimize heat circulation.
6. The power cord is 8 feet (2.43 m) long and may require a grounded extension cord to reach the nearest electrical outlet.
7. Stove must sit on a non-combustible pad that extends six inches in front of the door or the included hearth pad (50-3119).



www.nficertified.org

We recommend that our pellet hearth products be installed and serviced by professionals who are certified in the U.S. by the National Fireplace Institute® (NFI) as NFI Pellet Specialists or who are certified in Canada by Wood Energy Technical Training (WETT).



UNPACKING AND REMOVING PELLET STOVE FROM PALLET

1. Start by removing the crating and unit bag, you will need a pry bar and hammer to remove the crating. A sawzall can be used to cut the staples as well.
 2. Loosen six screws securing Back Grill, once loose slide downwards and remove.
 3. Remove the six T-20 screws that fasten each cabinet side to the stove. See Figure 1.
 4. Remove the 2 lag bolts on each side that hold the stove to the pallet. See Figure 2.
 5. Remove the 1/4" bolts that secure the shipping brackets to the stove. See Figure 3.

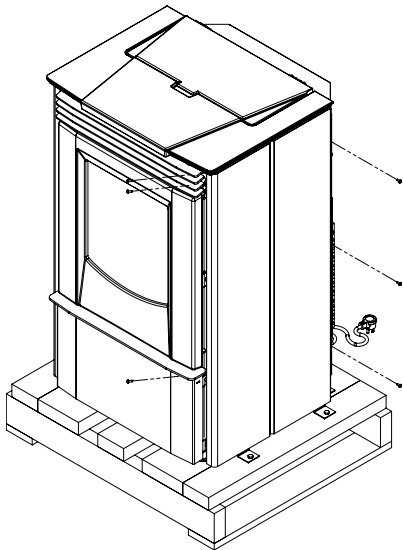

Figure 1: Cabinet Side Removal

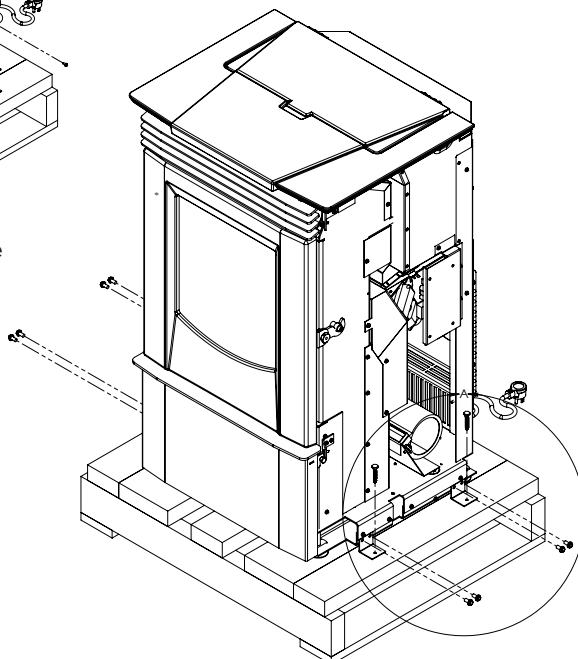

Figure 2: Shipping Bracket Removal

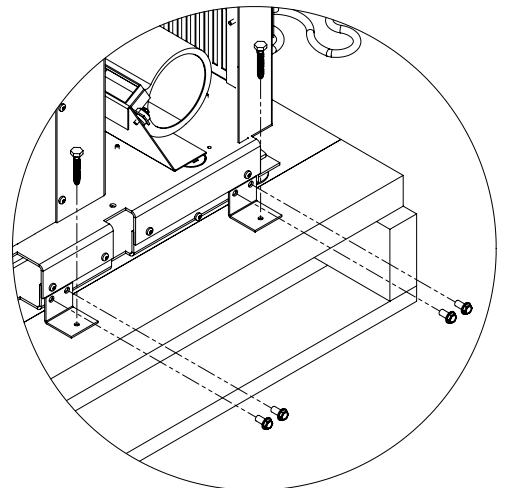

Figure 3: Shipping Bracket Removal

INSTALLATION

ASSEMBLY

1. First install the hearth pad if you plan on using it. You will need to install the Hearth Pad Mounting Tabs before installing the Hearth Pad. The Mounting Tabs are installed by screwing one #8-32 T-20 screw through the Hearth Pad and into each Mounting Tab (there are three total). See Figure 4a. You may have to unscrew feet to raise unit up. Tilt the unit so it is balancing on the back feet, slide the hearth pad under the unit while making sure the side mounting tabs are on the outside of the base flange. Once holes are aligned secure with provided T-20 thread rolling screws. See Figure 4b.

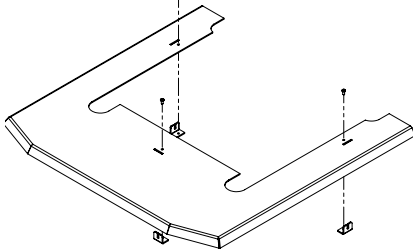

Figure 4a: Hearth Pad Tab Install

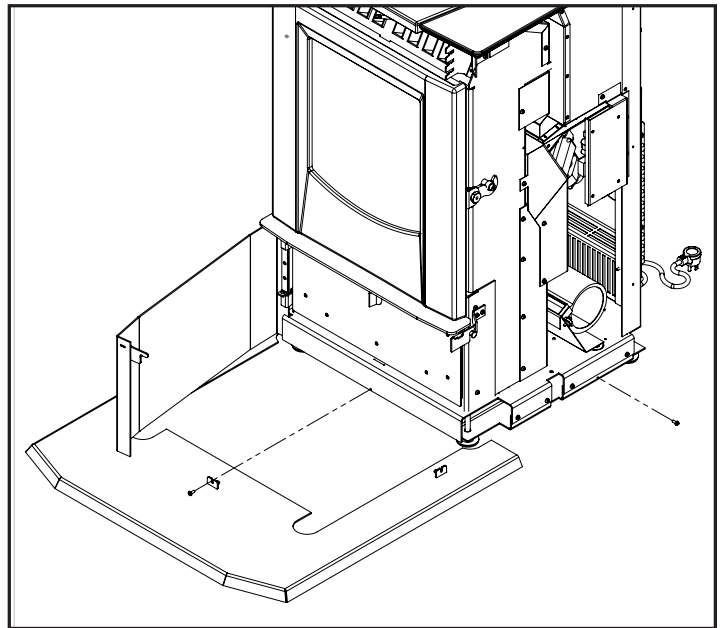

Figure 4b: Hearth Pad Install

2. Next install the Cabinet Sides. There are six screws for mounting each cabinet side. Start by installing screws at front top of the panels, Do not fully tighten screws. Now get the back top screws started. Now install the rest of the screws and tighten them down. See Figure 5.

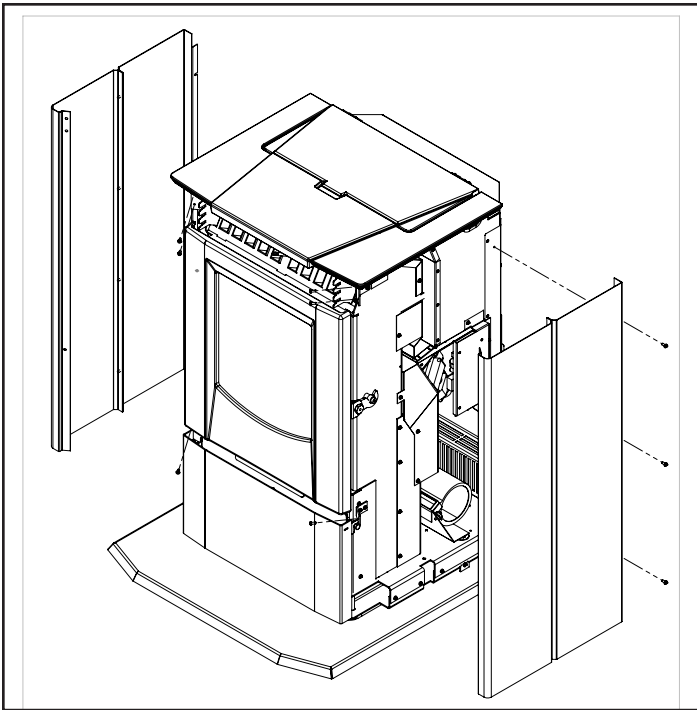

Figure 5: Cabinet Side Install

3. Now Install Ash Shelf and Louvers. Ash Shelf is mounted using two T-20 thread roller screws. The Louvers are installed by inserting into slots cut into louver mounting brackets located above the door. If properly aligned the louvers should catch on the bracket tabs and sit at a 15 degree angle.

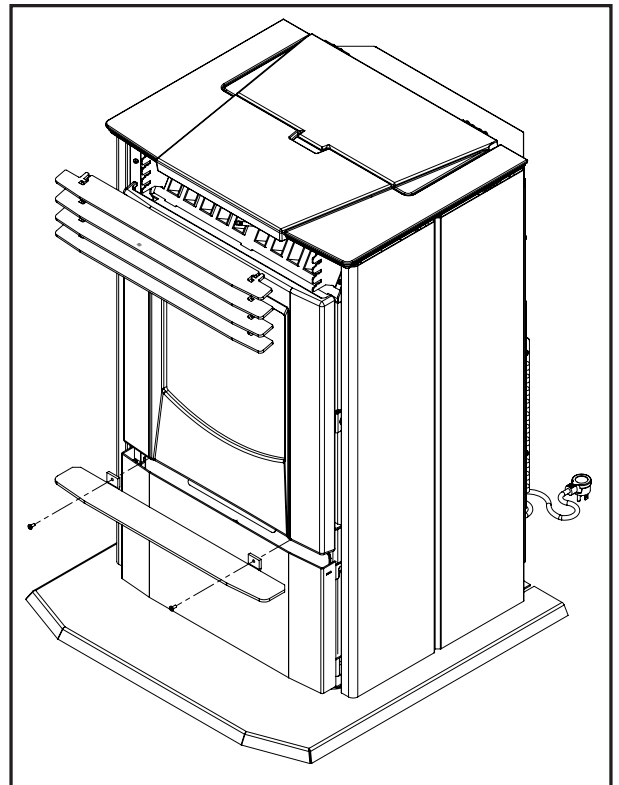

Figure 6: Louver and Ash Shelf Install

INSTALLATION

CLEARANCES TO COMBUSTIBLES:

IMPORTANT: The P4 must have a Hearth Pad when installing the unit on a combustible floor. The included hearth pad meet all the requirement of a proper hearth pad. If you do not use the included hearth pad a certified non combustible Hearth Pad with a minimum R Value of at least 0.84 must be placed underneath the unit and extend 7.25 inches in front of the unit measured from the glass. If the P4 is installed on carpet the use of a solid non combustible Hearth Pad must be used under leveling legs.

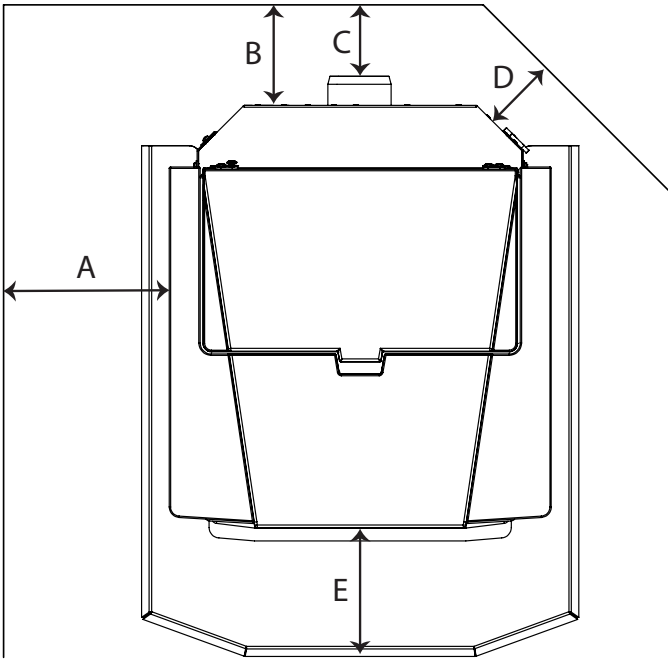

Figure 7: Minimum Install Clearances

These dimensions are minimum clearances but it is recommended that you ensure sufficient room for servicing, routine cleaning and maintenance.

A. Side wall to unit	6 inches	(20 cm)
B. Back wall to unit	8 inches	(20 cm)
C. Back wall to Chimney Connector	5 inches	(13 cm)
D. Corner to unit	3 inches	(7.5 cm)
E. Glass to Hearth Pad	7.25 inches	(18.5 cm)

ALCOVE CLEARANCES:

The unit may be installed in an alcove if desired. These minimum clearances to combustibles must be maintained at all times. Be sure to leave room for servicing, routine cleaning, and maintenance. These are inside dimensions.

Minimum Alcove Width	48 inches	(122 cm)
Minimum Alcove Height	48 inches	(122 cm)
Minimum Alcove Depth	48 inches	(122 cm)

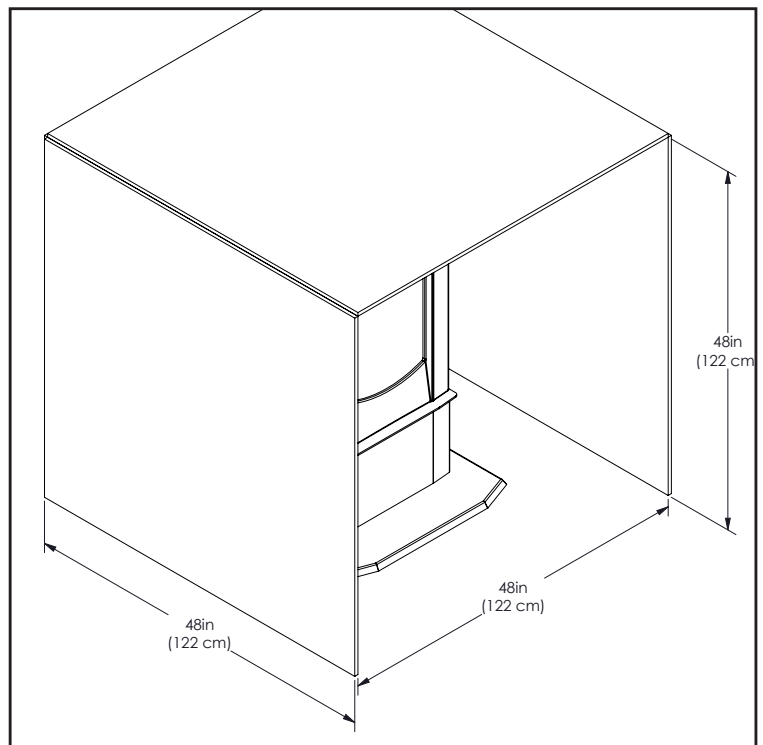

Figure 8: Minimum Alcove Clearances

INSTALLATION

VENT TERMINATION REQUIREMENTS:

IT IS RECOMMENDED THAT YOUR PELLETT STOVE BE INSTALLED BY AN AUTHORIZED DEALER/INSTALLER.

Table 1: Use in conjunction with Figure 6 for allowable exterior vent termination locations.

Letter	Minimum Clearance	Description
A	24 in (61 cm)	Above grass, top of plants, wood, or any other combustible materials.
B	48 in (122 cm)	Beside/below any door or window that may be opened. (18" (46 cm) if outside fresh air installed.)
C	12 in (30 cm)	Above any door or window that may be opened. (9" (23 cm) if outside fresh air installed.)
D	24 in (61 cm)	To any adjacent building, fences and protruding parts of the structure.
E	24 in (61 cm)	Below any eave or roof overhang
F	12 in (30 cm)	To outside corner.
G	12 in (30 cm)	To inside corner, combustible wall (vertical and horizontal terminations).
H	3 ft (91 cm) within a height of 15 ft (4.5 m) above the meter/regulator assembly	To each side of center line extended above natural gas or propane meter/regulator assembly or mechanical vent.
I	3 ft (91 cm)	From any forced air intake of other appliance
J	12 in (30 cm)	Clearance to non-mechanical air supply inlet to building, or the combustion air inlet to any appliance.
K	24 in (61 cm)	Clearance above roof line for vertical terminations.
L	7 ft (2.13 m)	Clearance above paved sidewalk or paved driveway located on public property.

- Do not terminate the vent in any enclosed or semi-enclosed areas such as a carport, garage, attic, crawlspace, narrow walkway, closely fenced area, under a sun deck or porch, or any location that can build up a concentration of fumes such as stairwells, covered breezeway, etc.

- Vent surfaces can become hot enough to cause burns if touched by children. Non-combustible shielding or guards may be required.

- Termination must exhaust above

the inlet elevation. It is recommended that at least five feet of vertical pipe be installed outside when the appliance is vented directly through a wall, to create some natural draft to prevent the possibility of smoke or odor during appliance shut down or power failure. This will keep exhaust from causing a nuisance or hazard from exposing people or shrubs to high temperatures. In any case, the safest and preferred venting method is to extend the vent through the roof vertically.

- Distance from the bottom of the termination and grade is 12" (30 cm) minimum. This is conditional upon the plants and nature of grade surface. The exhaust gases are hot enough to ignite grass, plants and shrubs located in the vicinity of termination. The grade surface must not be lawn.

- If the unit is incorrectly vented or the air to fuel mixture is out of balance, a slight discoloration of the exterior of the house might occur. Since these factors are beyond the control of Sherwood Industries Ltd, we grant no guarantee against such incidents.

NOTE: Venting terminals shall not be recessed into walls or siding.

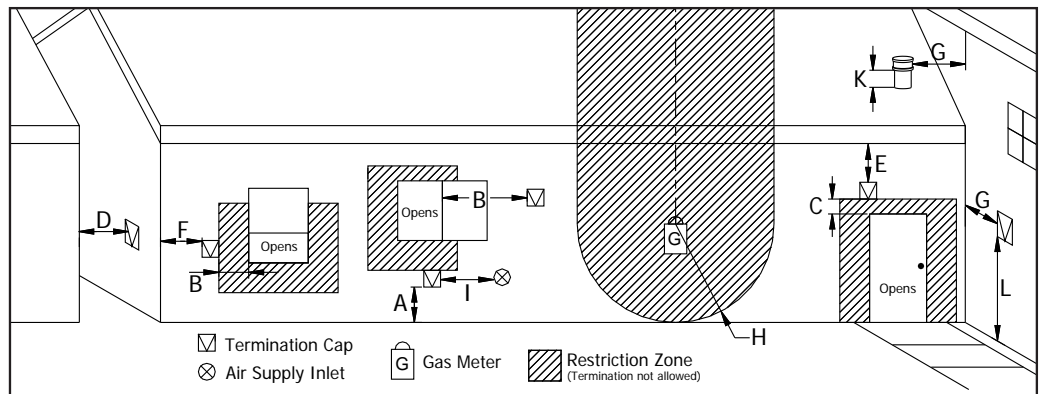

Figure 9: Use in conjunction with Table 1 for allowable exterior vent termination locations.

INSTALLATION

OUTSIDE FRESH AIR CONNECTION:

Outside fresh air is mandatory when installing this unit in airtight homes (R2000) and mobile homes.

A Fresh-air intake is strongly recommended for all installations. Failure to install a fresh air intake may result in improper combustion as well as the unit smoking during power failures.

When connecting to an outside fresh air source, do not use plastic or combustible pipe. A 2" minimum (51 mm) ID (inside diameter) steel, aluminum or copper pipe should be used. It is recommended, when you are installing a fresh air system, to keep the number of bends in the pipe to a minimum.

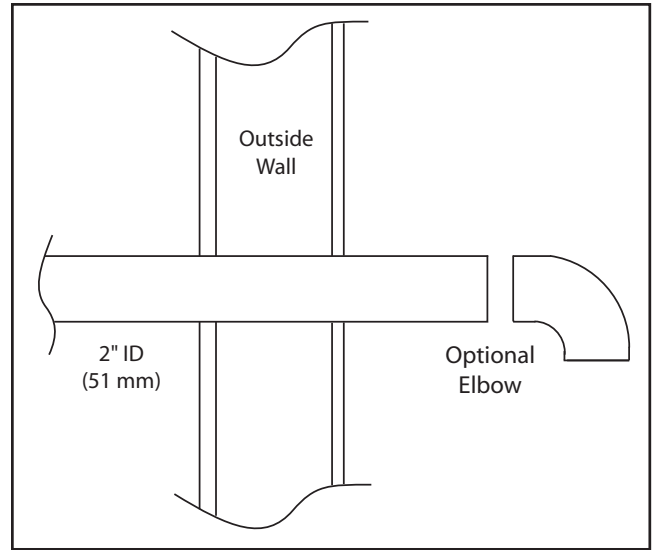

Figure 10: Outside Air Connection.

EXHAUST AND INTAKE LOCATIONS:

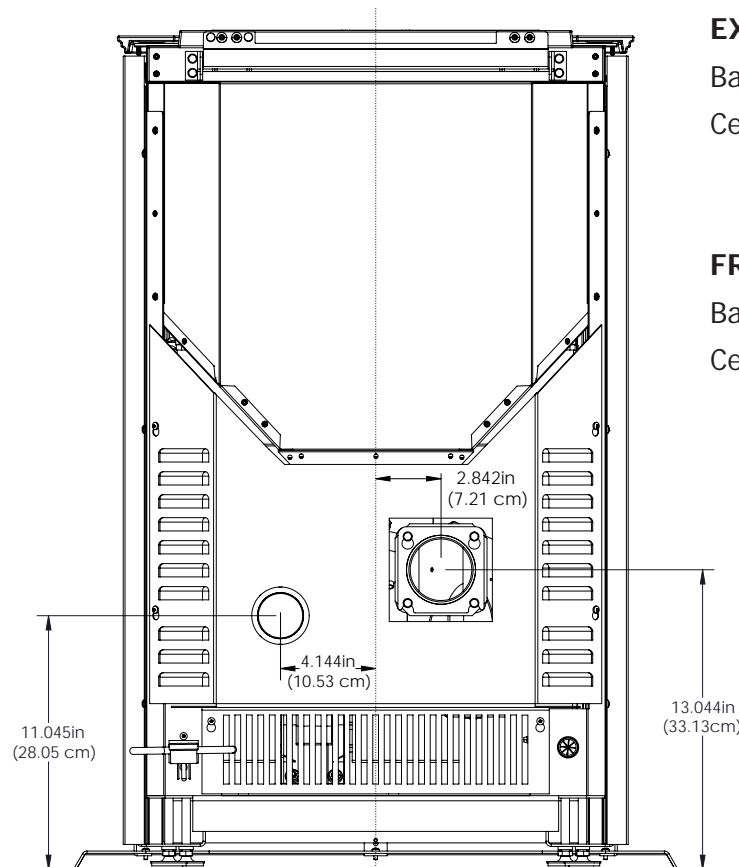

Figure 11: P4 Inlet and Outlet Location.

EXHAUST

Base of unit to center of flue	13.044 in (331 mm)
Center of unit to center of flue	2.842 in (72.1 mm)
	[at center of unit]

FRESH AIR INTAKE

Base of unit to center of intake	11.045 in (280.5 mm)
Center of unit to center of intake	4.144 in (53 mm)

IMPORTANT: When attaching the exhaust venting system to the unit or when joining vent sections three screws must be used at each joint. If vented horizontally, joints shall be made gas tight with aluminum foil duct tape.

INSTALLATION

MOBILE HOME INSTALLATION:

- Secure the heater to the floor using the two holes in the pedestal.
- Ensure the unit is electrically grounded to the chassis of your home (permanently).
- Do not install in a room people sleep in.
- Outside fresh air is mandatory. Secure outside air connections directly to fresh air intake pipe and secure with three screws evenly spaced.

CAUTION:

THE STRUCTURAL INTEGRITY OF THE MANUFACTURED HOME FLOOR, WALL AND CEILING/ROOF MUST BE MAINTAINED.

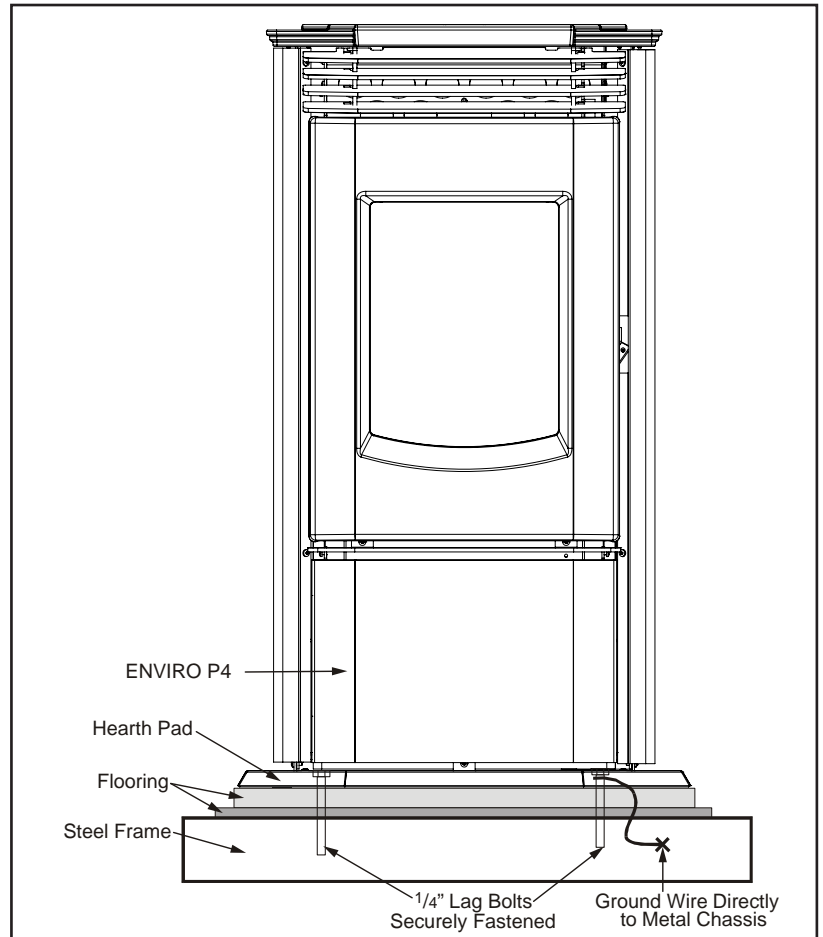

Figure 12: Mobile home installation.

CORNER THROUGH WALL INSTALLATION:

Minimum clearances must be maintained for a corner installation as shown in figure 13.

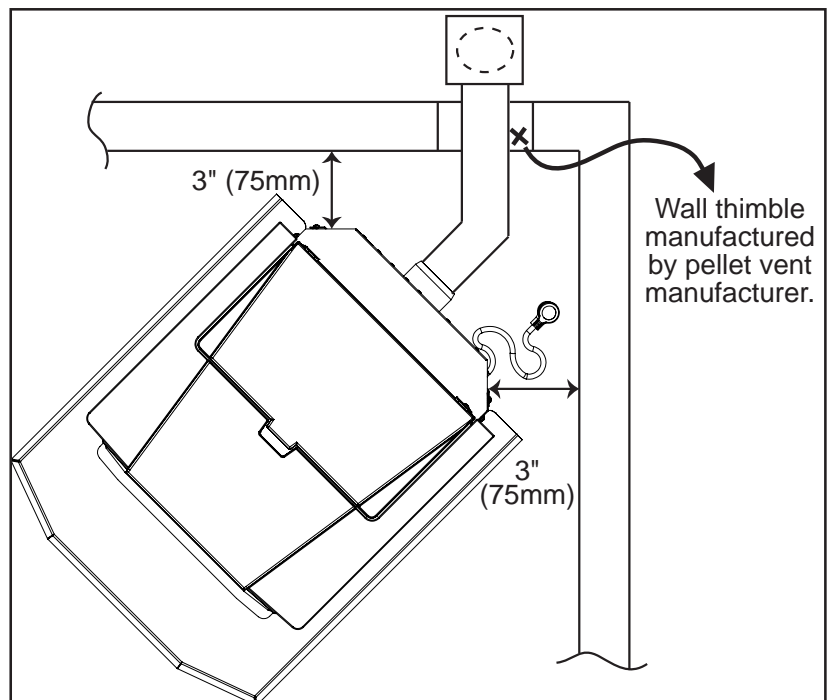

Figure 13: Corner Installation.

INSTALLATION

HORIZONTAL EXHAUST THROUGH WALL INSTALLATION:

Vent installation: install vent at clearances specified by the vent manufacturer.

A chimney connector shall not pass through an attic or roof space, closet or similar concealed spaces, or a floor, or ceiling. Where passage through a wall or partition of combustible construction is desired, the installation shall conform to CAN/CSA-B365 Installation Code for Solid-Fuel-Burning Appliances and Equipment. Only use venting of L or PL type with an inside diameter of 3 or 4 inches (7.6 or 10.1 cm).

1. Choose a location for your stove that meets the requirements stated in this manual and allows installation with the least amount of interference to house framing, plumbing, wiring, etc.
2. Install a non-combustible hearth pad (where necessary).
3. Place the appliance 15" (37.5 cm) away from the wall. If the stove is to be set on a hearth pad, set the unit on it, and adjust the leveling legs.
4. Locate the center of the exhaust pipe on the stove. Extend that line to the wall. Once you have located the center point on the wall, refer to pellet vent manufacturer installation instructions for correct hole size and clearance to combustibles.
5. Install the wall thimble as per the instructions written on the thimble. Maintain an effective vapour barrier in accordance with local building codes.
6. Install a length of 3" (75 mm) or 4" (100 mm) vent pipe into the wall thimble. The pipe should install easily into the thimble.
7. Connect the exhaust vent pipe to the exhaust pipe on the stove. Seal the connection with high temperature silicone.
8. Push the stove straight back, leaving a minimum of 4" (10 cm) clearance from the back of the stove to the wall. Seal the vent pipe to the thimble with high temperature silicone.
9. The pipe must extend at least 12" (30 cm) away from the building. If necessary, bring another length of pipe (PL type) to the outside of the home to connect to the first section. Do not forget to place high temperature silicone around the pipe that passes through the thimble.

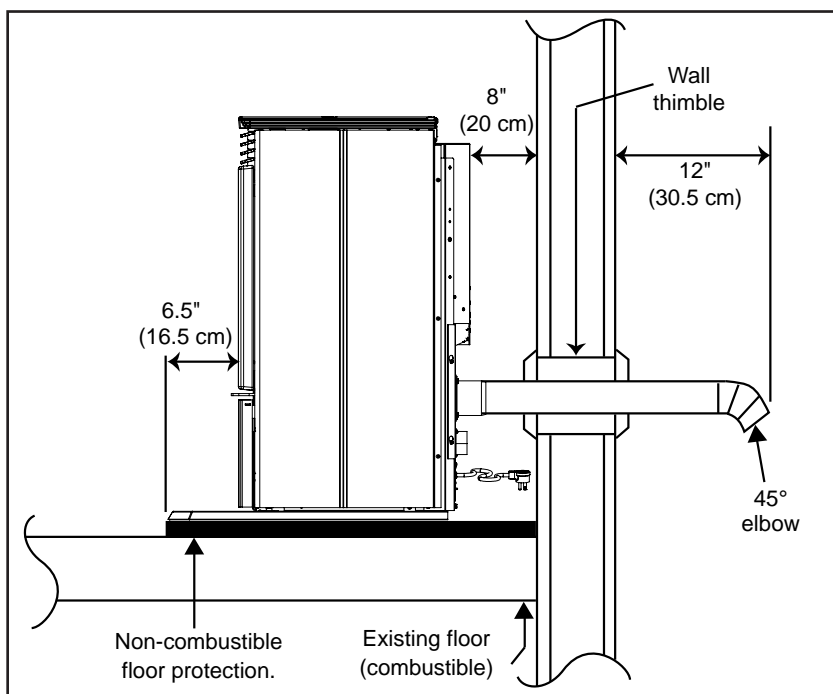

Figure 14: Straight through wall Installation.

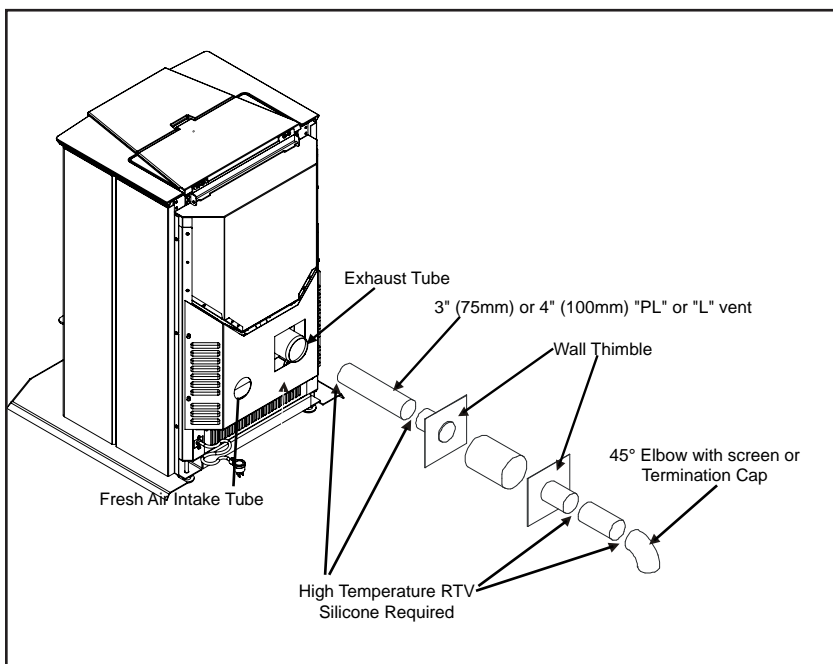

Figure 15: Venting to use with straight through wall Installation.

INSTALLATION

10. Install a vertical pipe, or if all requirements for direct venting are met, install vent termination. The stainless steel cap termination manufactured by the vent manufacturer is recommended. However, when the vent terminates several feet above ground level and there are no trees, plants, etc. within several feet, a 45° elbow can be used as termination. The elbow must be turned down to prevent rain from entering.

NOTE:

- It is recommended that horizontal through wall installations have 3 to 5 feet (91 to 152 cm) of vertical pipe in the system to help naturally draft the unit in the event of extreme weather or a power outage.
- Some horizontal through wall installations may require a "T" and 3 to 5 feet (91 to 152 cm) of vertical pipe outside the building to help draft the unit. This may be required if a proper burn cannot be maintained, after the stove has been tested and the airflow set. This is due to the back pressure in the exhaust caused by airflow around the structure.
- Follow vent manufacturer guidelines for installation of venting. High temp sealant must be used when connecting vent pipe to the unit's starter pipe. Improper seals at the vent joints may cause combustion by-products to leak into the room where installed - **seal as required**.

THROUGH WALL VERTICAL RISE HORIZONTAL TERMINATION INSTALLATION - FREESTANDING:

A termination cap is always recommended for this type of install but a stainless steel termination hood or a 45° elbow may be used in place of the cap.

Figure 16 is the recommended installation set up, venting length is negligible.

Figure 17 is the installation to use if there is a concrete or retaining wall in line with exhaust vent on a pellet stove. The termination must be 12" (30 cm) from the outside wall and 12" (30 cm) above the ground.

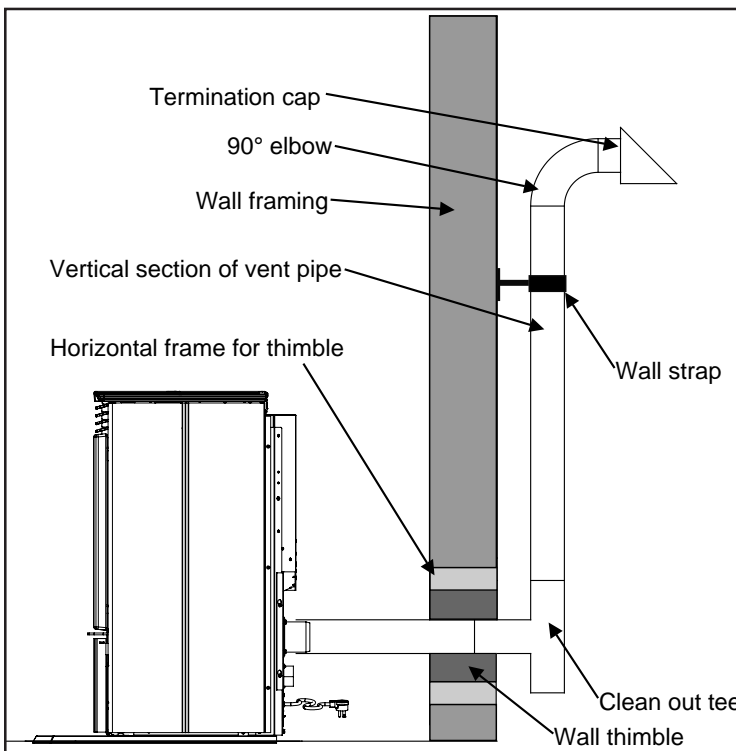

Figure 16: Venting horizontally with rise.

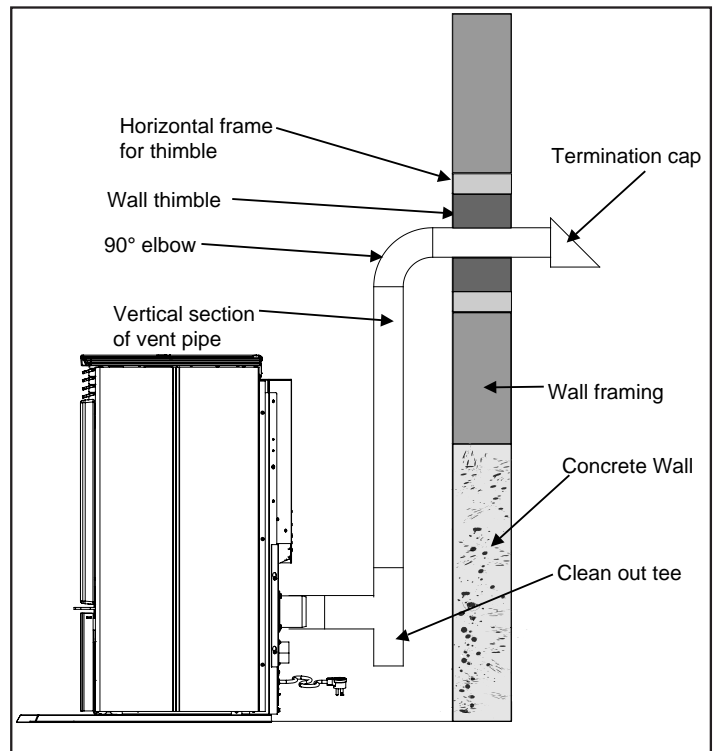

Figure 17: Venting with concrete wall behind unit .

INSTALLATION

INSIDE VERTICAL INSTALLATIONS:

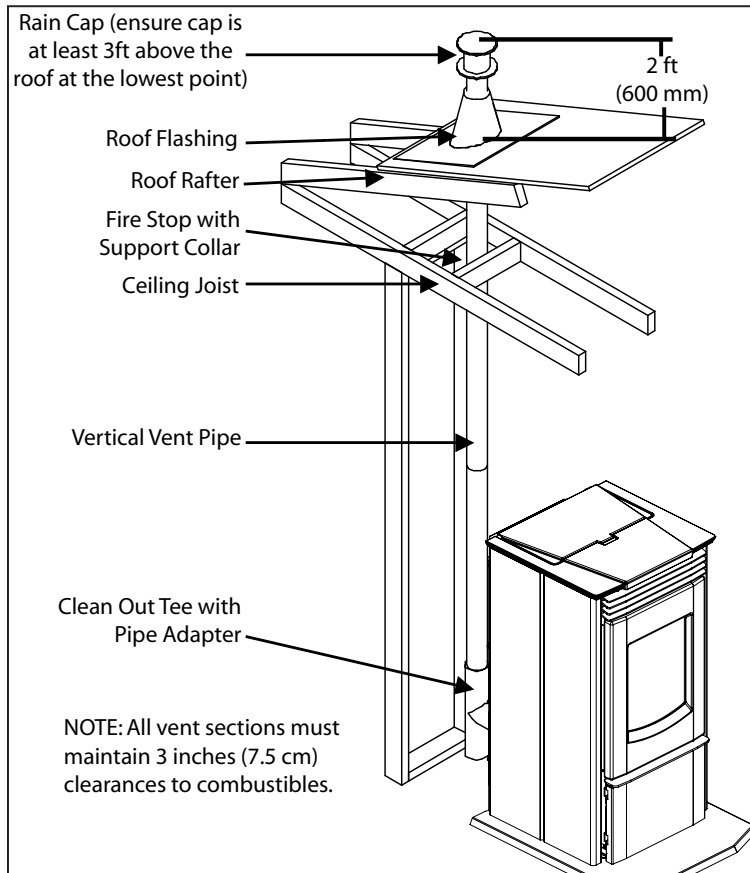

Figure 18: Inside Vertical Installation.

1. Choose a stove location that is ideal. See the section "DECIDING WHERE TO LOCATE YOUR PELLET APPLIANCE."
2. Place a non-combustible hearth pad where necessary.
3. Place the unit on the hearth pad (if installed on a combustible surface) and space the unit in a manner so when the pellet vent is installed vertically, it will be 3" (7.5 cm) away from a combustible wall.
4. Install the tee with clean out.
5. Install the pellet vent upward from there. When you reach the ceiling, make sure that the vent goes through the ceiling fire stop. Maintain a 3" (7.5 cm) distance to combustibles and keep attic insulation away from the vent pipe. Maintain an effective vapor barrier.
6. Finally, extend the pellet vent to go through the roof flashing.
7. Ensure that the rain cap is approximately 24" (600 mm) above the roof.

OUTSIDE VERTICAL INSTALLATIONS:

To accomplish a outside vertical pipe installation, follow steps 1 through 5 in the "INSIDE VERTICAL INSTALLATIONS - FREESTANDING" section and then finish it by performing the following (refer to Figure 19).

1. Install a tee with clean out on the outside of the house.
2. Install PL vent upward from the tee. Make sure that you install support brackets to keep the vent straight and secure.
3. Install ceiling thimble and secure the flashing as you go through the roof.
4. Ensure that the rain cap is approximately 24" (600 mm) above the roof.

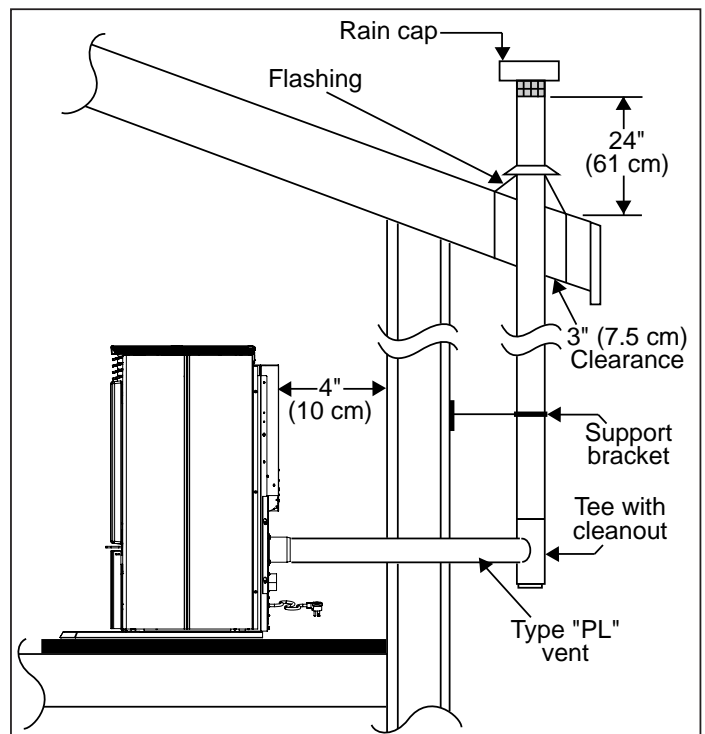

Figure 19: Outside Vertical Installation.

INSTALLATION

HEARTH MOUNT INSTALLATION:

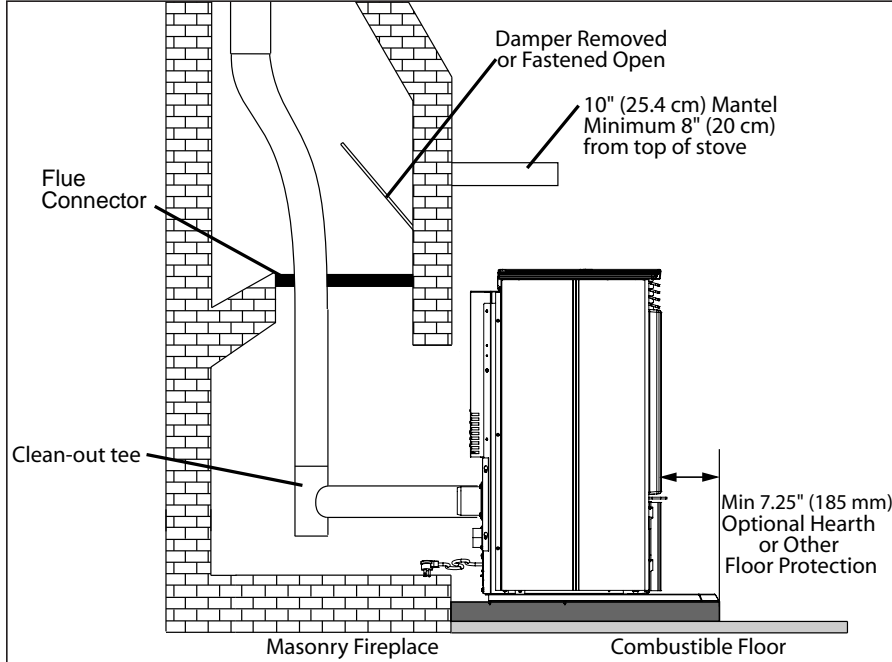

Figure 20: Freestanding hearth mount installation.

Refer to Figures 20 and 21.

1. Install the hearth pad.
2. Lock the fireplace damper in the open position.
3. Install a positive flue connector at the fireplace dampers or seal the chimney at the top.
4. Connect a tee to the exhaust pipe.
5. Install flexible stainless steel liner or listed pellet vent to the top of the chimney.

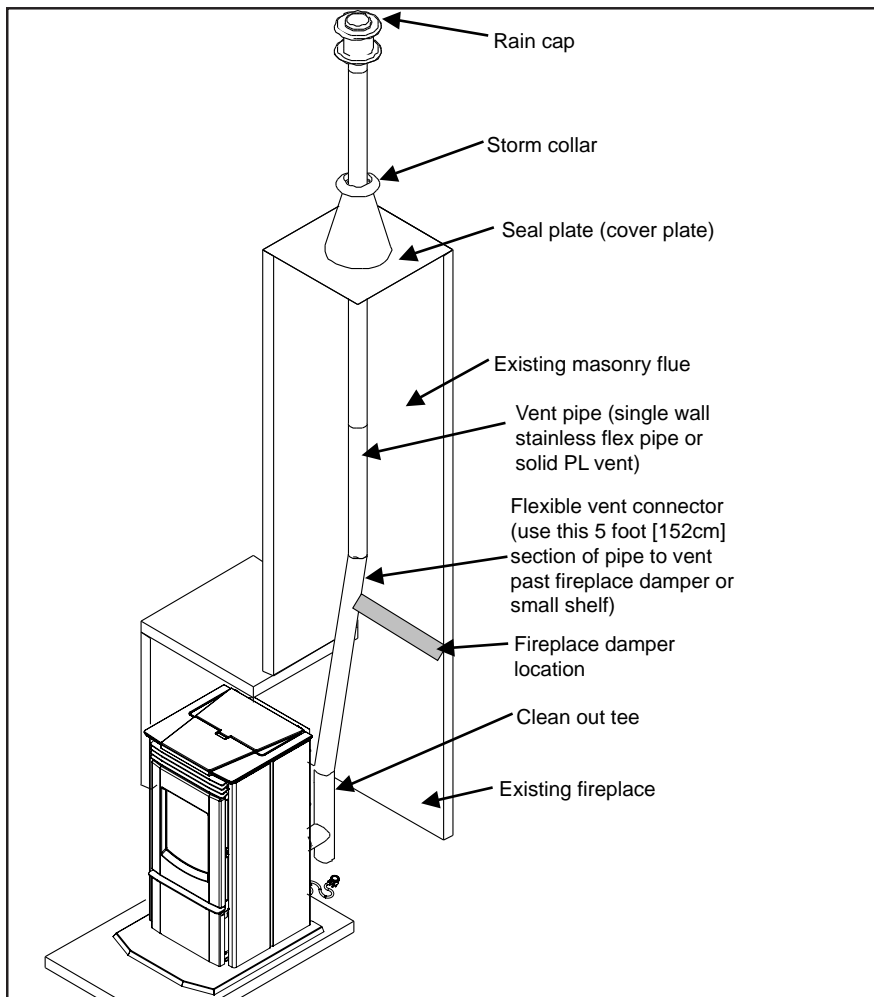

Figure 21: Freestanding hearth mount installation overview.

INSTALLATION

THERMOSTAT INSTALLATION:

1. Install the wall thermostat in a location that is not too close to the unit but will effectively heat the desired area.
2. The Right Cabinet Side will need to be removed to access the Control Board. There are six T-20 screws that need to be removed on the Right Cabinet Side before it can be removed.

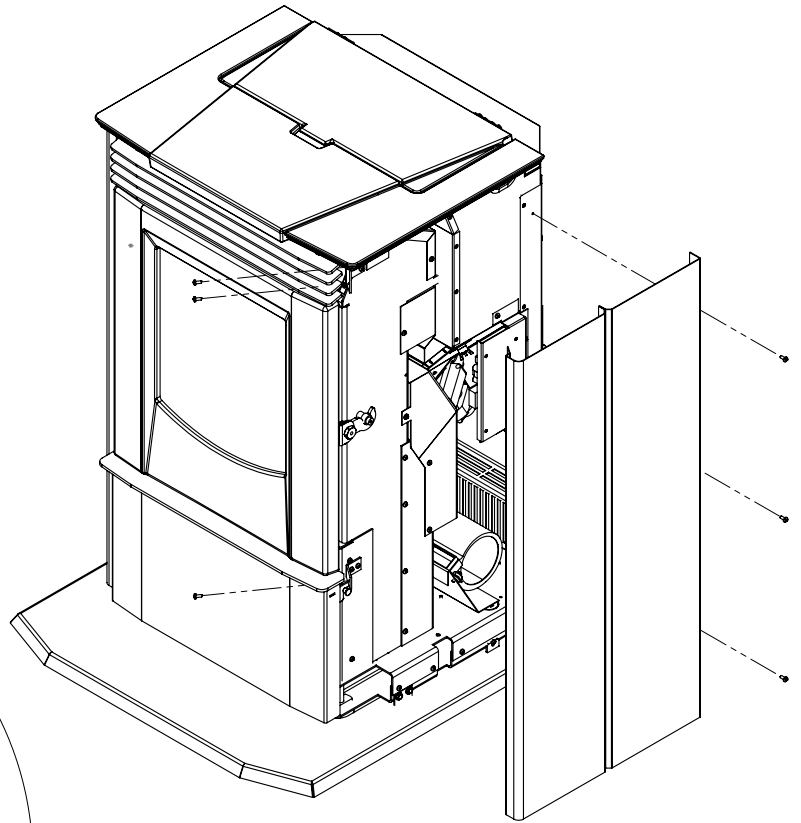

Figure 22: Cabinet Removal

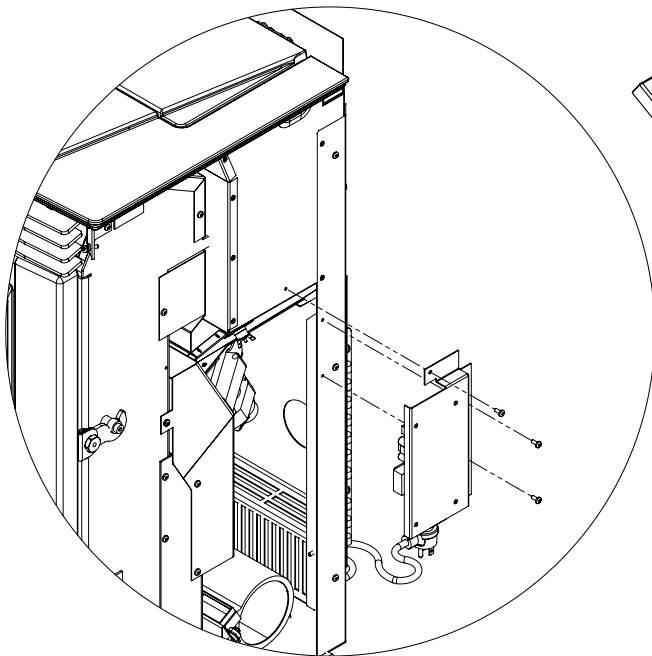

Figure 23: Control Board Cover Removal.

3. Once the side has been removed you can remove three T-20 screws securing the Control Board Cover.
4. Once the Control Board is out, you can easily access the circuit board and will be able to attach the thermostat wires to the thermostat connection shown in Figure 24.
5. Use a small flat head screwdriver to tighten and secure the wires. The wires should be run through the plastic bushing located at the back of the stove, opposite side from the power.
6. Reverse steps 1-5.

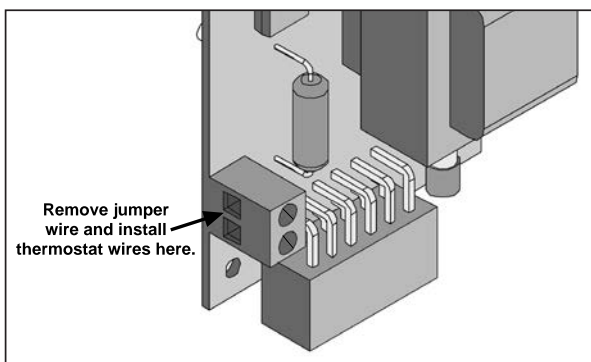
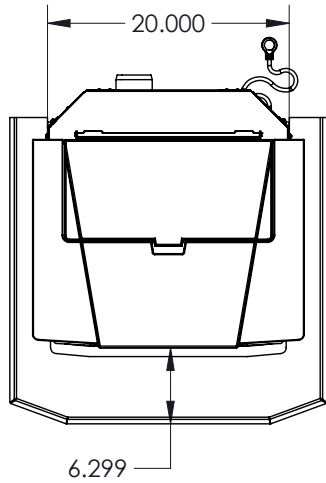

Figure 34: Thermostat wire placement.

SPECIFICATIONS

DIMENSIONS AND SPECIFICATIONS:



Weight (with full hopper): 275 lb (125 Kg)
 Hopper Capacity: up to 60 lb (27 Kg)
 Voltage: 110 - 120 V
 Max Current: 4.1 Amps
 Consumption on High: 3.1 lb/hr (1.4 Kg/hr)*
 Consumption on Low: 1.3 lb/hr (0.6 Kg/hr)*
 (Note: Consumption will vary with the type of fuel used.)

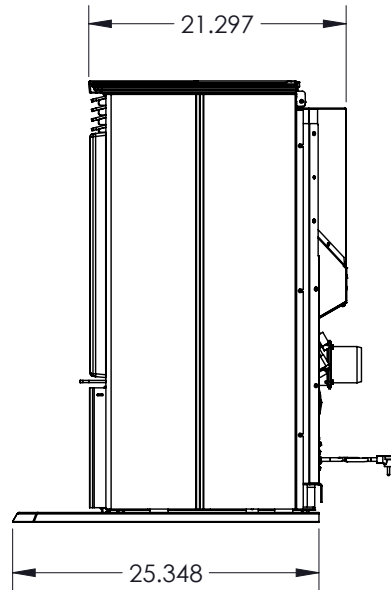
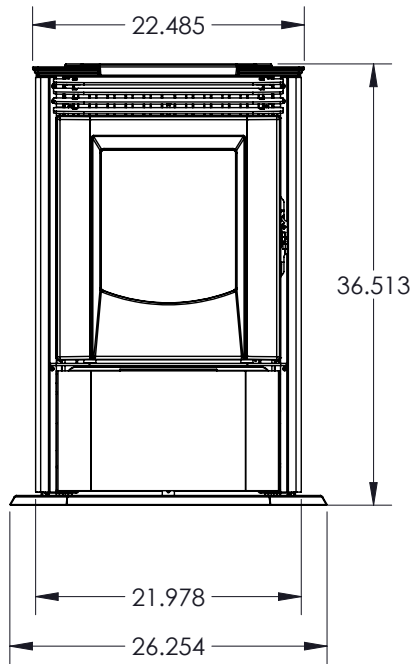

DATE: 23/06/2015	BY	SHERWOOD INDUSTRIES LTD.
UPDATED: ---/--/--	BY --	INTERNAL ASSEMBLY MANUAL
STOVE: P4		REVISION: 0.0
		SHEET: 1 of 1

THIS DRAWING IS THE PROPERTY OF SHERWOOD INDUSTRIES LTD. AND MAY NOT BE COPIED, REPRODUCED, OR OTHERWISE DISCLOSED WITHOUT THE PRIOR APPROVAL OF SHERWOOD INDUSTRIES LTD.

Figure 25: Dimensions of P4.

OPERATING INSTRUCTIONS

CONTROL BOARD FUNCTIONS:

1. **POWER BUTTON:** This is the green button with the power symbol, it is used to turn the unit on and off. When the power is on and the blue LED beside the button will be illuminated. The LED will flash during the start-up cycle. Once start-up cycle is complete the power LED will stay on.
2. **AUTO BUTTON:** Located below the Power button, when pressed this activates Auto or "Comfort" mode. LED beside button will be illuminated when active.
3. **THERMOSTAT BUTTON:** Located below the Auto Button. This is for external thermostat control. LED beside button will be illuminated when active.
4. **ARROW BUTTONS:** The Arrow Buttons are used to adjust heat level and trim settings.

START-UP: When the unit is turned on it will go into a start-up cycle while trying to light a fire. During start-up you have no control over the settings. The Power LED will flash until start-up is complete. You can adjust heat levels or toggle the different modes during start-up but these adjustments will not come into affect until the start-up cycle is complete.

MANUAL MODE: Once the start-up cycle is completed you will be in either Manual mode or Auto mode. When in Manual mode the Power LED is illuminated and AUTO LED is not. Use the Arrow buttons to adjust heat level from L1-L5.

AUTO MODE: Press the Auto button to activate Auto or "Comfort" mode. When activated the Power and Auto LED's will be illuminated. Use the Arrow buttons to adjust from C1-C9. Each setting corresponds to a different temperature set point. The stove will automatically adjust to hold this temperature. As the room temperature gets close to the set point the fire will decrease in size. If room temperature is above the set point for a certain amount of time the stove will shut down and go into Suspend mode.

SUSPEND MODE: Once a stove has gone into Suspend mode the fire will go out. This means the room has heated up beyond the Auto set point. Once temperature in the room drops below the Auto set point the stove start back up and run until the room gets to hot once again. When in suspend mode the Auto LED will flash.

THERMOSTAT MODE: This can only be used in Manual mode, and is for external thermostat control. A external thermostat can be wiring to the main control board. When activated the LED beside the Thermostat Button will be illuminated.

FEED/COMBUSTION TRIM: To adjust the Feed Trim you must be in Manual mode heat level 1. Press the hidden button located under the down arrow. The Display will then change from P (Program) to A (Auger) to C (Combustion) with a two second delay between changes. When the display shows an A use the arrows to adjust the feed trim. To adjust the combustion fan trim wait until the display shows C then use the arrows to adjust.

SERVICE INDICATOR: If you see the "S1" on the LED display this is a maintenance recommended indicator. The "S1" will come on when your stove has run for so many hours. It is recommended that you contact your local dealer for component inspection and servicing. Pellet stoves require regular maintenance to keep running efficiently.



Figure 26: Circuit Board Control Panel Decal.

AUTOMATIC SAFETY FEATURES OF YOUR PELLET STOVE:

- A. The stove will shut off if the fire unexpectedly goes out, once exhaust temperature drops below 120°F (49°C), you will see an **E3** code on the LED display.
- B. The stove has a high temperature safety switch. If the temperature on the hopper reaches 200°F (93°C), the auger will automatically stop and the stove will shut down. The LED display will show an **E4** error code, see Troubleshooting section. If this happens, call your local dealer to reset the 200°F (93°C) high limit switch. **ALSO FIND THE REASONS WHY THE UNIT OVERHEATED.** This code can also be cause by leaving the hopper lid open, there is a magnetic safety switch.
- C) The unit is equipped with a vacuum switch to monitor the venting pressure; if it becomes blocked the vacuum switch will turn off the auger and there will be an **E2** error code on The LED Display.

OPERATING INSTRUCTIONS

OPERATION YOUR PELLET STOVE:

PRE-BURN INSTRUCTIONS: The burn pot liner holes must be clear and the liner installed properly against the ignitor tube for proper operation. Check the hopper for enough pellets to start the unit.

DO NOT OPERATE THE UNIT WITH THE DOOR OR ASH PAN OPEN.

TO START: Press the Power button. The stove will turn on. The LED beside the Power button will flash to indicate a start-up cycle. The Heat Level is shown on the LED display, you can change the Heat Level and mode but these adjustments will not take affect until the start-up cycle is complete. If this is the first time the unit has been started or the unit has run out of fuel, the auger will need to be primed. You may need restart the unit if an **E3** error occurs, to do this just press the Power button again. Once you see pellets start to drop the auger is primed.

TO OPERATE: When a fire has been established, the Power LED will turn solid (after approximately 10 - 15 minutes) and the current settings will now take affect.

The convection blower (room air blower) will turn on once the start-up cycle is complete. The speed of this blower is automatically controlled and is based off the heat level setting.

TURNING YOUR PELLET STOVE OFF:

To turn off your Pellet stove just press the Power button. This will not shut off the stove instantly, it will go into a shut down cycle and take approximately 5 minutes for the fire to burn out. The fans will stay running until the unit has cooled sufficiently.

NEVER unplug a unit that is running!

DO NOT unplug unit while Combustion fan is running.

Unplugging may cause smoke to be released into the home.

DAMPER SET-UP:

DAMPER MUST BE SET AT TIME OF INSTALLATION. This is used to regulate the airflow through the pellet stove, this is key to an efficient clean burn. See figure 27.

If the pellets being burnt are of poor quality there is a higher chance of clinker build up and over time the fire may build up and overflow the burn pot. Poor quality pellets will require more primary air to help complete the burn, the slider damper must be pulled out to compensate. Pulling the slider damper out gives the fire more air. It is crucial to make sure the burn pot is clean and that no holes are blocked for proper combustion. It is recommended to get the stove hot then set the damper at heat level 1, this is the most sensitive setting.

There are two ways to set the damper. You can visually set the damper if you have experience.

- A tall, lazy flame with dark orange tips requires more air – Open slider (pull out) slightly.
- A short, brisk flame, like a blowtorch, has too much air – Close slider (push in) slightly.
- If the flame is in the middle of these two characteristics with a bright yellow/orange, active flame with no black tips then the air is set for proper operation, refer to Figure 28.

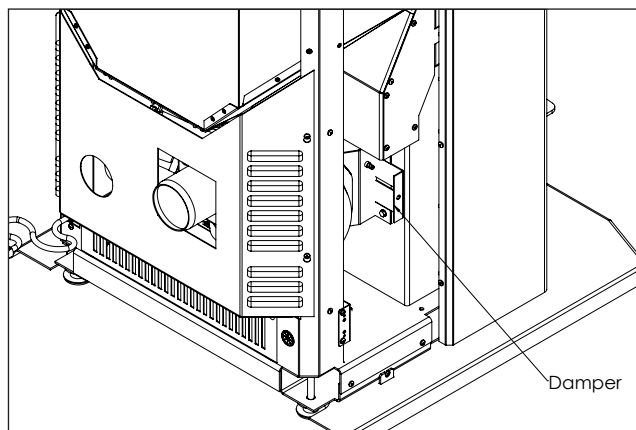

Figure 27: Slider/Damper Adjustment

OPERATING INSTRUCTIONS

For less experienced installers or owners a magnehelic gauge can be used to determine the proper Damper setting. A magnehelic gauge will accurately measure the pressure in your firebox. There is a small hole on underneath the ash lip on the right side of the firebox front, see figure 29. You want a reading of .10-.13 WC (25-32 Pa) depending on pellet quality.

The combustion exhaust blower is a variable speed blower controlled by heat level setting. This blower will decrease the vacuum pressure inside the stove as the heat level output is decreased.

SPECIAL NOTES:

Pellet quality is a major factor in how the Pellet stove will operate. If the pellets have a high moisture content or ash content the fire will be less efficient and has a higher possibility of the fire building up and creating clinkers (hard silica ash build-up).

Overfiring should not occur if stove is operating properly, if stove looks like it is burning unusually high turn off the unit with the power button, **DO NOT** unplug. There is a built in safety switch if unit gets too hot from overfiring it will shut down automatically.



Figure 28: Efficient Flame.

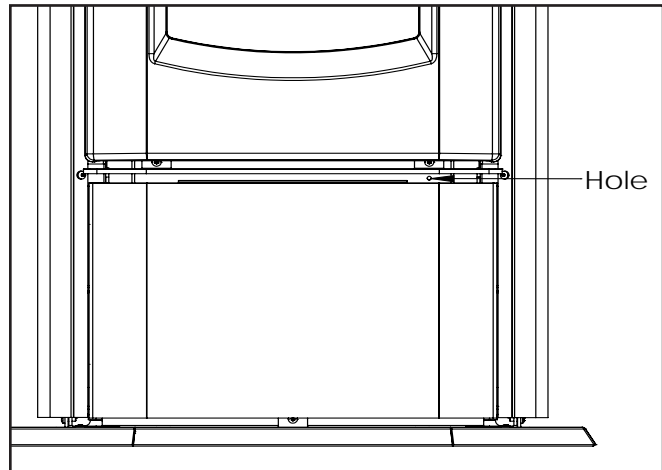

Figure 29: Magnehelic Test Hole.

GUIDELINES FOR FINE-TUNING FOR FUEL QUALITY:

Due to fuel quality the damper and control board trims may need to be fine-tuned to achieve optimal conditions. Trims are accessed by pressing hidden button below the down arrow when in L1.

1. If ash builds up in the unit on all settings, the slider damper rod should be pulled out in small increments to give the unit more air.
2. If the unit has excesses ash build-up in the liner on the lower feed settings, the Combustion Blower Trim should be increased one setting at a time until the problem improves (Factory Setting is #3).
3. If the fire is going out on low because the airflow is too great, the Combustion Blower Trim can be lowered one setting at a time.
4. If the stove has excesses ash build-up in the liner on the higher settings the damper can be opened until the problem improves.
5. If you need more heat and the fuel has long pellets, the majority are over 1" (2.5cm) in length, the Feed Rate Trim can be increased.

ROUTINE CLEANING AND MAINTENANCE

The following list of components should be inspected and maintained routinely to ensure that the appliance is operating at its' optimum and giving you excellent heat value:

<u>2-3 Days / Weekly</u>	<u>Semi-annually or 2 Tons of Fuel</u>
Burn Pot and Liner	Exhaust Vent
Heat Exchanger Tubes	Air Intake
Ash Pan	Blower Mechanisms
Door Glass	Heat Exchanger Tubes
Inside Firebox	Behind Firebox Liners & Covers
Ash Pan and Door Gaskets	All Hinges
Door Latch	Post Season Clean-up

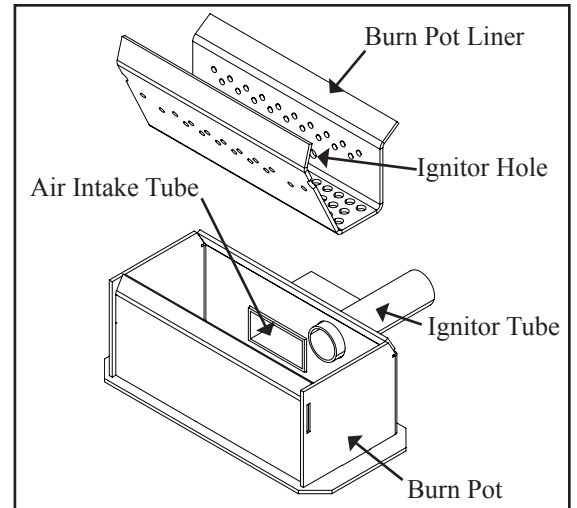

Figure 30: P4 Burn pot and Liner

TOOLS REQUIRED TO CLEAN UNIT:

Torx T-20 Screwdriver, $\frac{5}{16}$ " wrench or socket, Brush, Soft Cloth, Vacuum with fine filter bag

BURNER POT AND LINER (2-3 days)

Every two to three days (when the unit is cold), remove the burn-pot liner from the stove. Using a metal scraper, remove material that has accumulated or is clogging the liner's holes. Then dispose of the scraped ashes from the liner and from inside the burn-pot. Place the burn-pot back into the stove, making sure that the pipes are properly inserted into the burn pot. Place the liner back into the burn-pot, making sure that the ignitor hole in the liner is aligned with the ignitor tube (shown in Figure 30). Push the liner up against the ignitor tube.

If after long periods of burning, the fire continually builds up and overflows the burn pot or there is a build up of clinkers, this is an indication that the pellet fuel quality is poor, the stove may need cleaning, or the air adjusted. Check the stove for ash build up (clean if required) and adjust the damper to produce the proper clean combustion.

HEAT EXCHANGER TUBES (2-3 days)

A rod is located in the center of the stove just above the door behind the top louvers, see Figure 35. This rod is to be pulled up and down a few times (ONLY WHEN THE UNIT IS COLD) in order to clean away any fly ash that may have collected on the heat exchanger tubes. As different types of pellets produce different amounts of ash, cleaning of the tubes should be done on a regular basis to enable the unit to run efficiently. Do not pull on rod excessively if it is not sliding. If stuck inspect rod for bend and try and free up scraper plate from inside firebox.

ASH PAN AND DOOR GASKETS (weekly)

After extended use the gasket may come loose. To repair this, glue the gasket on using high-temperature fiberglass gasket glue available from your local dealer. This is important to maintain an airtight assembly.

ROUTINE CLEANING AND MAINTENANCE

DOOR GLASS CLEANING (2-3 days)

Cleaning of the glass must only be done when stove is cold. Open the door. The glass can be cleaned by wiping down the outside and inside of the glass with a soft dry cloth.

If the glass has build up that can not be removed with only the cloth, clean the glass using paper towel and a gas appliance glass cleaner, this may be purchased through most dealers. If a gas appliance glass cleaner is not available, use a damp paper towel dipped in fly ash to clean the glass. After the glass has been cleaned use the dry soft cloth to wiping down the outside and inside of the glass.

ASH PAN (weekly)

This part is located behind the bottom door. To remove the ash pan, open the cover from the right hand side, and lift the ash pan up and out. Dump the ashes into a metal container stored away from combustibles. Monitor the ash level every week. Remember that different pellet fuels will have different ash contents. Ash content is a good indication of fuel efficiency and quality. Refer to "SAFETY WARNINGS AND RECOMMENDATIONS" for disposal of ashes. Vacuum the inside of the ash pan compartment inside the pedestal including the hole at the top back of the compartment. Replace the ash pan, close the latch, and close pedestal door. **DO NOT PLACE UNBURNED OR RAW PELLET FUEL IN ASH PAN.**

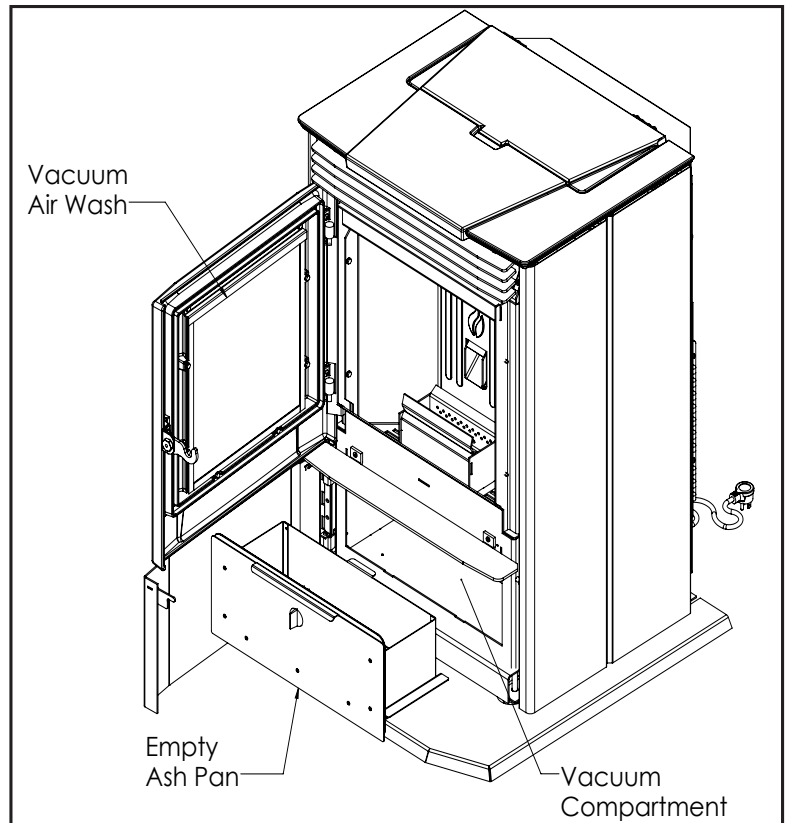

Figure 31: P4 Open

AIR INTAKE (semi-annually)

Inspect periodically to be sure that it is not clogged with any foreign materials.

EXHAUST PASSAGES (Semi-annually)

To prevent build up of fly-ash all the exhaust passages must be cleaned and vacuumed.

ROUTINE CLEANING AND MAINTENANCE

HEAT EXCHANGER TUBES (2-3 days)

- The heat exchanger tubes are located behind the Louver assembly. To access Heat Exchanger Scraper Rod, remove middle two louvers by tipping up and pulling out.
- Pull out the Scraper Rod shown in Figure 32 in order to remove any fly ash that may have collected on the heat exchanger tubes. This will allow for optimal heat transfer to convection air.

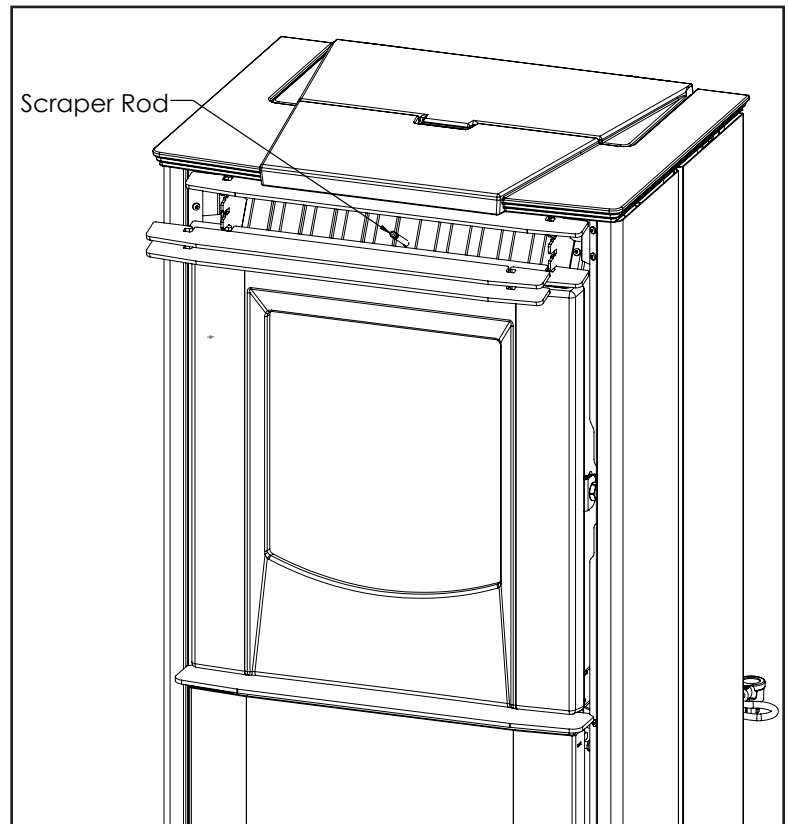

Figure 32: P4 Heat Exchanger Tubes

REMOVAL OF FIREBOX PANELS

- Open the door, remove the door, burn pot and burn pot liner.
- Lubricate all screws with penetrating oil.
- Remove the four screws that hold the side panels in place.
- With the tip of a flat screwdriver, gently lift up the side panels and remove the side panels.
- Pull the center panel out.
- Vacuum thoroughly.
- Re-install panel by inserting center panel.
- Place the side panels back into the firebox locking them into place and re-install the two screws on each side.
- Clean thoroughly.

Note: Screws that secure left side panel also secure hinge bracket which holds cast door. Remove door before unscrewing.

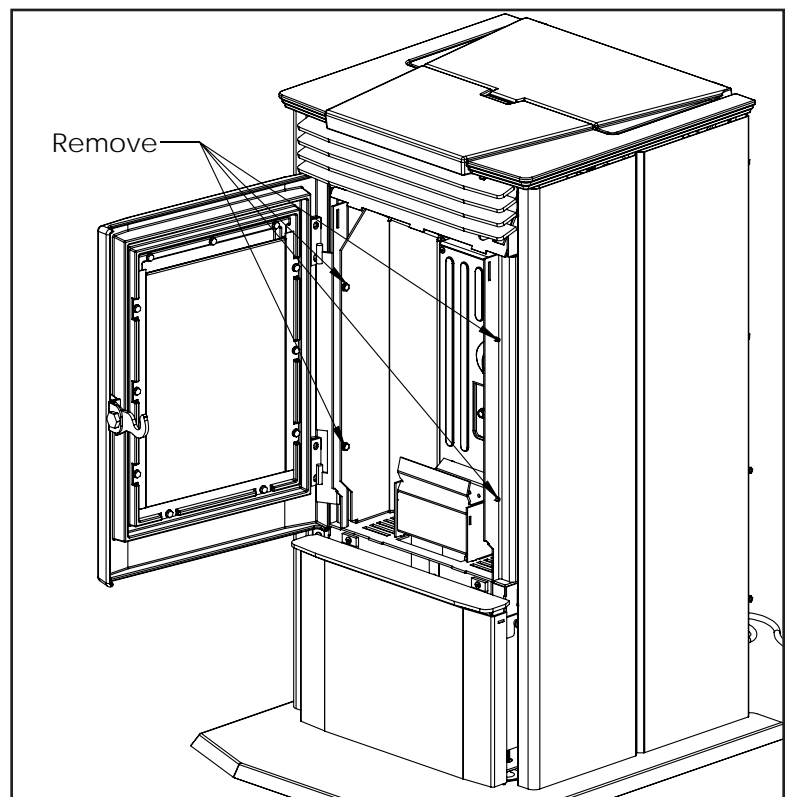

Figure 33: P4 Firebox Panels

ROUTINE CLEANING AND MAINTENANCE

FIREBOX (weekly)

The paint on the steel firebox panels may peel. This is due to extreme conditions applied to the paint and is in no way covered by warranty. Brush and vacuum up all soot and flyash from firebox.

AIR WASH (semi-annually)

Vacuum out the air wash passages at the top of the glass (see Figure 33). We recommend that a soft brush nozzle head is used on the vacuum.

EXHAUST VENT (semi-annually)

This vent should be cleaned every year or after two tons of pellets. We recommend contacting your dealer for professional cleaning. To clean the vent pipe, tap lightly on the pipe to dislodge any loose ash. Open the bottom of the "T" to dump the ash, then vacuum as much of the ash out of the vent pipe as possible. Failure to clean exhaust venting can result in a serious creosote fire.

BLOWER MECHANISMS (semi-annually)

Unplug the stove then open the right and left side panels to access the two blowers. Vacuum all dust from motors. DO NOT lubricate the motors. Check gaskets and replace if needed.

HINGES

Check to make sure all hinges are working properly. You may use high temp anti-sieze on door hinges for smoother operation.

POST SEASON CLEAN-UP

Once you are finished using the pellet appliance for the season, unplug the stove for added electrical protection. It is very important that the stove be thoroughly cleaned and serviced. Pellet should be regularly serviced for optimum efficiency and prolonged life.

DOOR GLASS REPLACEMENT

Never run a stove with broken glass, new glass must be purchased and installed by a Enviro dealer. The door glass is made of high temperature "PYROCERAM" ceramic glass. The proper glass size is 13" x 9.5" x 0.2" (5mm). To replace the glass, unscrew and remove the seven retainer screws. Carefully remove the glass and any broken pieces using protective gloves. High temperature fiberglass tape should be used around the glass on the sides and bottom. Place glass with fiberglass tape around outside into cast door, there should be no gasket at the top. Use the same retainers to secure the glass in place, make sure glass is properly seated in the cast door before tightening screws. Do not strike or slam door shut this can cause glass to break. The use of substitute glass materials is prohibited use only part 50-2942.

How can I reduce the visible emissions?

If all of the steps for cleaning and operating are followed, there should be no visible emissions.

TROUBLESHOOTING

DO NOT:

- Service the stove with wet hands. The stove is an electrical appliance, which may pose a shock hazard if handled improperly. Only qualified technicians should deal with possible internal electrical failures.
- Do not remove any screws from the firebox without penetrating oil lubrication.

WHAT TO DO IF:

1. The stove will not start.
2. E2 on LED Display.
3. E3 on LED Display.
4. E4 on LED Display.
5. The Exhaust Blower will not function normally.
6. The Auger is not feeding pellets.
7. The Convection Blower will not function normally.
8. The Igniter not working.
9. Control settings (Heat Level) has no effect on the fire.

***NOTE: All troubleshooting procedures should be carried out by qualified technicians or installers.**

1. The stove will not start.

- Make sure the stove is plugged in and the wall outlet is supplying 115-120V AC power.
- If the Control Board has been is set to Thermostat mode, turn the thermostat up to call for heat.
- Check the LED display for error codes. - If Display reads **E2,E3**, or **E4** use Troubleshoot sections.
- Check the fuses on the circuit board.
- If the unit still does not start, contact your local service dealer for service.

2. E2 on LED Display (The Vacuum Switch contacts have opened for more than 1:00 min)

- Pinch, break or blockage in Vacuum Hose - Check hose for pinch points or damage, replace or re-route as required. Blow out Vacuum Hose with compressed air.
- Blocked Hose Barb on Exhaust Channel - Use a paper clip to clean out Hose Barb or remove the Vacuum Hose from the Vacuum Switch and blow into the hose to remove blockage.
- Blocked exhaust / venting system - Have stove and venting cleaned and inspected.
- Air Damper is closed or set to low - open damper slightly.
- Severe negative pressure in area where unit is installed - Check the operation by opening a window, does this solve the problem? If it does, install fresh air intake to unit or room. Venting system may require vertical section to move termination into a low pressure zone.
- Vacuum Switch failure - Bypass the vacuum switch, if this corrects the problem check for above problems before replacing the Vacuum Switch.
- Damage to gray wires between Circuit Board and Vacuum Switch - Inspect wires and connectors
- Combustion Blower failure - If the Combustion Blower is not turning fast enough to generate the proper vacuum in the Exhaust Channel. Visually Check if the blower motor is turning, check the Exhaust Blower voltage across the blower wires ($\geq 115V$ on #5 setting and $\geq 82V$ on #1 setting). – Replace the Circuit Board if the Voltage reading is less than 82 V. with a line voltage $>115 V AC$.
- Check Vacuum levels in the exhaust channel by bypassing the vacuum switch, then remove the Vacuum hose from Vacuum Switch. Check exhaust vacuum readings by placing the open end of the Vacuum Hose on a Magnehelic Gauge. (readings must be above .09" WC on low fire).
- If the motor fails to reach a 0.09" WC readings, then replace the Combustion Blower

To reset Circuit Board after a trouble code - press Power button.

TROUBLESHOOTING

3. E3 on LED Display (Proof of Fire Failure)

- If a fire is not detected, or if the fire has gone out the display will read E3 because the exhaust temperature is too low causing Exhaust Temperature Sensor's contacts to open.
- Check the hopper for fuel. Auger may need to be primed if stove has run out of pellet or being fired for the first time.
- Incorrect air damper setting. - Excessive air may consume the fire too quickly before the next drop of fuel, leaving completely unburned fuel in the burn pot liner. - Insufficient air will cause build up, further restricting the air flow through the Burn Pot Liner. This in turn will cause the fuel to burn cold and very slowly. Fuel may build up and smother the fire. In this case clean the burn pot. **(NOTE: unit may require a changes to the vent system or installation of fresh air intake to correct Air to Fuel ratio problems).**
- Combustion Blower failure. - The Combustion Blower is not turning fast enough to generate the proper vacuum in the fire box. Visual Check – is the blower motor turning.
- Check the Exhaust Blower voltage across the blower wires ($\geq 114V$ on #5 setting and $\geq 82V$ on #1 setting). – Replace the Circuit Board if the Voltage reading is less than 82 V. with a line voltage $>114 V AC$.
- Check Vacuum levels in the exhaust channel by bypassing the Vacuum Switch, then remove the Vacuum hose from Vacuum Switch. Check exhaust vacuum readings by placing the open end of the Vacuum Hose on a Magnehelic Gauge (readings must be above .10" WC on low fire).
- Poor Quality Fuel – Insufficient energy in the fuel to produce enough heat to keep the stove burning or operational.
- Exhaust Temperature Sensor failure. – Bypass the sensor located on Exhaust Blower, if stove now operates properly, the unit may require cleaning or a new sensor. Contact your local dealer for service.
- Check the fuse on the circuit board.

4. E4 on LED Display (High Limit or Lid Switch Failure)

- If unit has been running normally and you now have an E4 this could be a High Limit switch. This is a safety feature, if the hopper gets too hot the unit will shut off. The High limit switch is located the right side of the hopper near the bottom.
- If the high limit has tripped something is wrong with the unit, possibly a component failure or a hopper fire has occurred.
- Slowly open the hopper lid, if you see and smoke at all keep it closed. A fire extinguisher or water can be used to put out a fire.
- If there is no smoke the Hopper Lid switch may not be engaged or there has been a component failure. The components will need to be tested, contact an Enviro dealer. The High limit switch is a manual reset switch and a small red button on the back of the switch will need to be manually pressed in order for the unit to be started again.
- To check Hopper Lid switch make sure Hopper Lid is fully closed, If you think it is properly closed, open and close the lid, you should hear an audible click from magnetic Hopper Lid switch located in control board area.
- If no click is heard check that magnet on underside of Hopper Lid is still magnetic. This is a strong magnet.
- If magnet is good, alignment is out or switch is bad.
- Test switch for audible click with another magnet, switch is right above LED Display on control board.

5. The Combustion Blower will not function normally.

- If the Combustion "Exhaust" Blower is not functioning properly the stove will most likely will give an E2 or E3 error code.
- Check the wiring against the wiring diagram to make sure everything is connected properly.
- The fan can be directly hooked up to power to check motor.

NOTE: DO NOT attempt any electrical troubleshooting without knowledge of electrical systems, make sure unit is not plugged in. It is recommended to call an authorized Enviro dealer or service technician.

TROUBLESHOOTING

6. Auger is not Feeding Pellets.

- If this is the first time starting the unit or during the previous burn the unit ran out of pellets the Auger will need to be primed. You may get an E3 while auger is filling with pellets, just press the power button again. Once the Auger is full of pellets it will start dropping them into the burn pot.
- If Auger is primed and no pellets are dropping remove the Rear Grill to see Auger motor, you will see the auger collar and set screw rotating if the Auger is operating properly.
- If the motor's armature tries to spin but the auger shaft doesn't then the auger is jammed. – Try to break apart jam by poking at the jam through the drop tube. If this fails then empty the hopper and remove the Auger Cover ****Remember to re-seal the cover with silicone after clearing jam****
- Check the set screw locking the motor shaft to the auger shaft. This needs to be tightened to the flat on the motor shaft for proper rotation.
- Check the fuses on the main circuit board.

7. The Convection Blower will not function normally.

- The Convection fan should come on when the unit is started. Speed is automatically controlled, the higher the heat level the higher the convection fan voltage will be.
- Check Wiring against wiring diagram.
- AC wall voltage can be directly hooked up to fan to test motor.
- Check that blade spins with very little friction.
- Check fuses on main circuit board.

8. Ignitor not working

- If pellets are feeding and the combustion blower is working your stove should light a fire or at least start smoking.
- Make sure the burn pot and burn pot liner are correctly installed square to the Ignitor and air tube.
- If stove errors out before lighting open door and carefully check to see if pellets around the Ignitor hole are warm - If not remove ignitor and test, replace if it does not heat up.
- If the air damper is closed too much or Combustion Blower is not working the stove will not light.
- Check the fuses on the main circuit board.

9. Control settings (Heat Level) has no effect on the fire.

- If the LED beside the Power button is flashing the Control Board has complete control of the unit. This means the unit is in start-up mode, once the start-up cycle is complete the light will go solid.
- If running in Auto or "Comfort mode" and the LED light beside the Auto button is flashing the unit is in suspend mode because it has overshoot the set point. Once temperature drops below the set point the stove will turn back on.

WIRING DIAGRAM

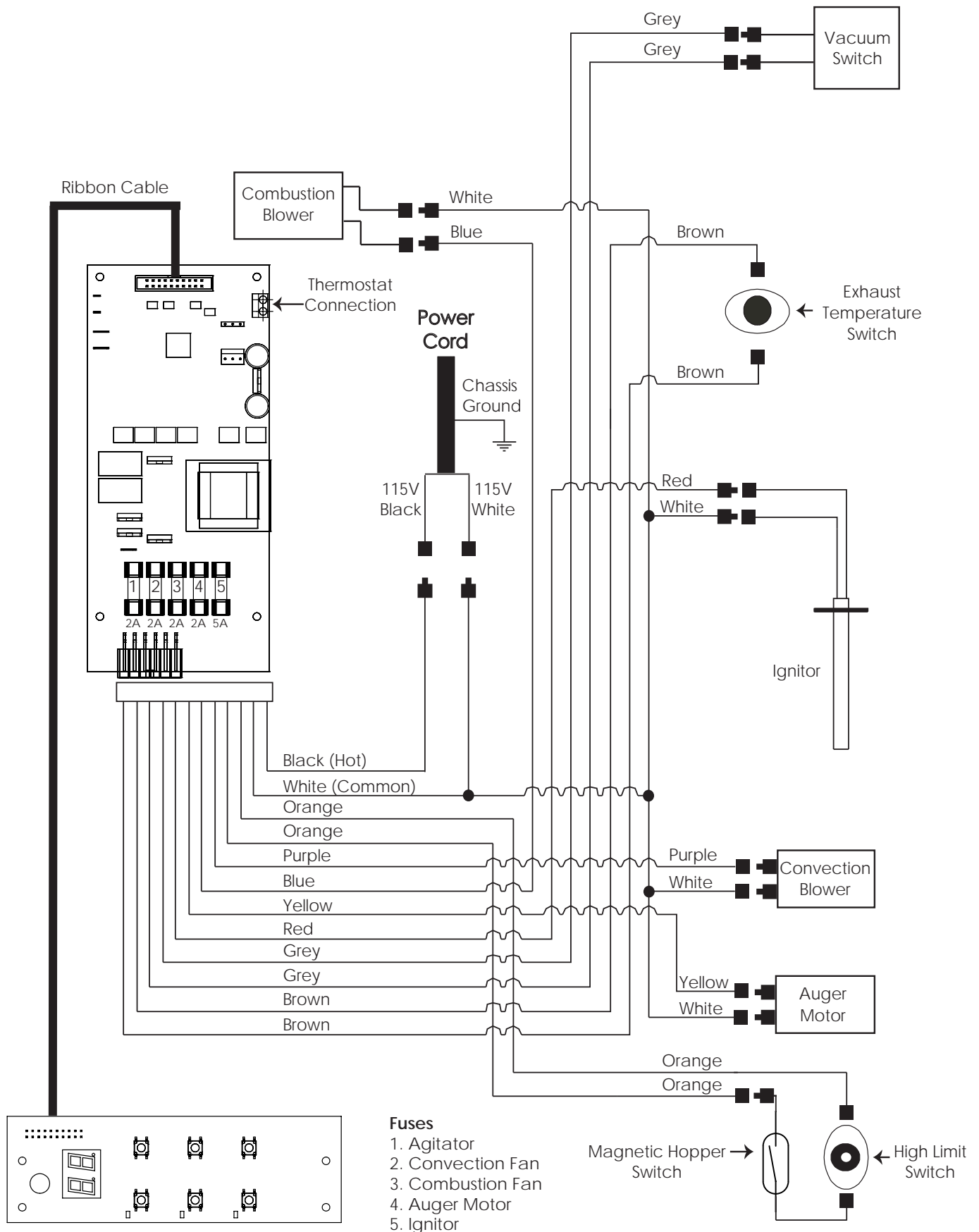

PARTS LIST

Reference Number	Description	Part Number
1	120 °F (49 °C) Ceramic Fan Temperature Sensor	EC-001
2	Auger Motor - 115V	EF-001
3	High Limit Temp Sensor 200°F (93°C) Manual Reset	EF-016
4	Vacuum Switch - 115V	EF-017
5	Silicone Hose	EF-018
6	SS Ash Pan Latch	50-2588
7	Domestic Power Cord - 115V	EC-042
8	400 Watt Ignitor - 115V	50-619
9	Exhaust Blower Assembly - 115V	50-901
10	Convection Blower - 115V (No Mount)	50-512
11	Leveling Legs (Set of 4)	50-1342
12	Hopper Switch (Magnetic)	50-2052
13	P4 Glass with Gasket	50-3116
14	LED Motherboard	50-2943
15	LED Daughterboard	50-2944
16	Control Decal	50-2948
17	Ash Pan with SS Latch	50-3117
18	Draft Slider	50-1579
19	Starter Pipe 3"	50-1185
20	Burn Pot	EF5-128
21	Burn Pot Liner	20-054
22	Auger with Paddles Weldment	50-1085
23	Auger Stop Plate	50-3118
24	P4 Hearth Pad with Mounting Hardware	50-3119
25	P4 Cabinet Sides and Ash Shelf (Painted)	50-3120
26	P4 Cabinet Sides and Ash Shelf (Racing Red)	50-3121
27	P4 Cabinet Sides and Ash Shelf (Modern Grey)	50-3122
28	P4 Cast Top	50-3123
29	P4 Cast Hopper Lid	50-3124
30	P4 Cast Door Assembly	50-3125
31	P4 Firebox Panel Set with Insulation	50-3126
32	Top Cast Mount Plate	50-3127
33	Hopper Hinge Set (Left and Right)	50-3128
34	Top Cabinet Mount Set (2)	50-2955
35	Bottom Cabinet Mount Set (2)	50-2956
36	Door Hinge Weldment	50-2957
37	Louver Bracket Set (Left and Right)	50-3129
38	Louver Set	50-3130

PARTS LIST

Reference Number	Description	Part Number
39	P4 Rear Cover	50-3131
40	Steel Door Latch	50-2961
41	Ash Pan Access Door	50-3132
42	Ash Pan Access Door Hinge Set (2)	50-3133
	Motherboard Mounting Bracket	50-2964
44	Daughterboard Mount Box	50-3134
45	Heat Exchanger Scraper Rod	50-2966
46	Machined Door Latch Nut	50-2967
	P4 Door Gasket 54" with Jont Tape	50-3135
	Aluminum Hose Barb (Vacuum Line)	EF-019
	Auger Brass Bushings (Set of 2)	50-1806
	Circuit Board 2 Amp Fuse - 115V (Single)	50-2075
	Circuit Board 5 Amp Fuse - 115V (Pair)	50-833
	5/8" ID Auger Collar with Screw	50-968
	Wire Harness	50-1157
	Auger Stops (Clear Tube)	50-1559
	Burnpot Scraper Tool	50-1254
	Cleaning Brush	EF-156
	Door Tool	50-2969
	P4 User Manual	50-3136
	25ft Extension Probe	50-3005
	Combustion Blower Motoe w/ Impeller Only	EF-161-A

PARTS DIAGRAM

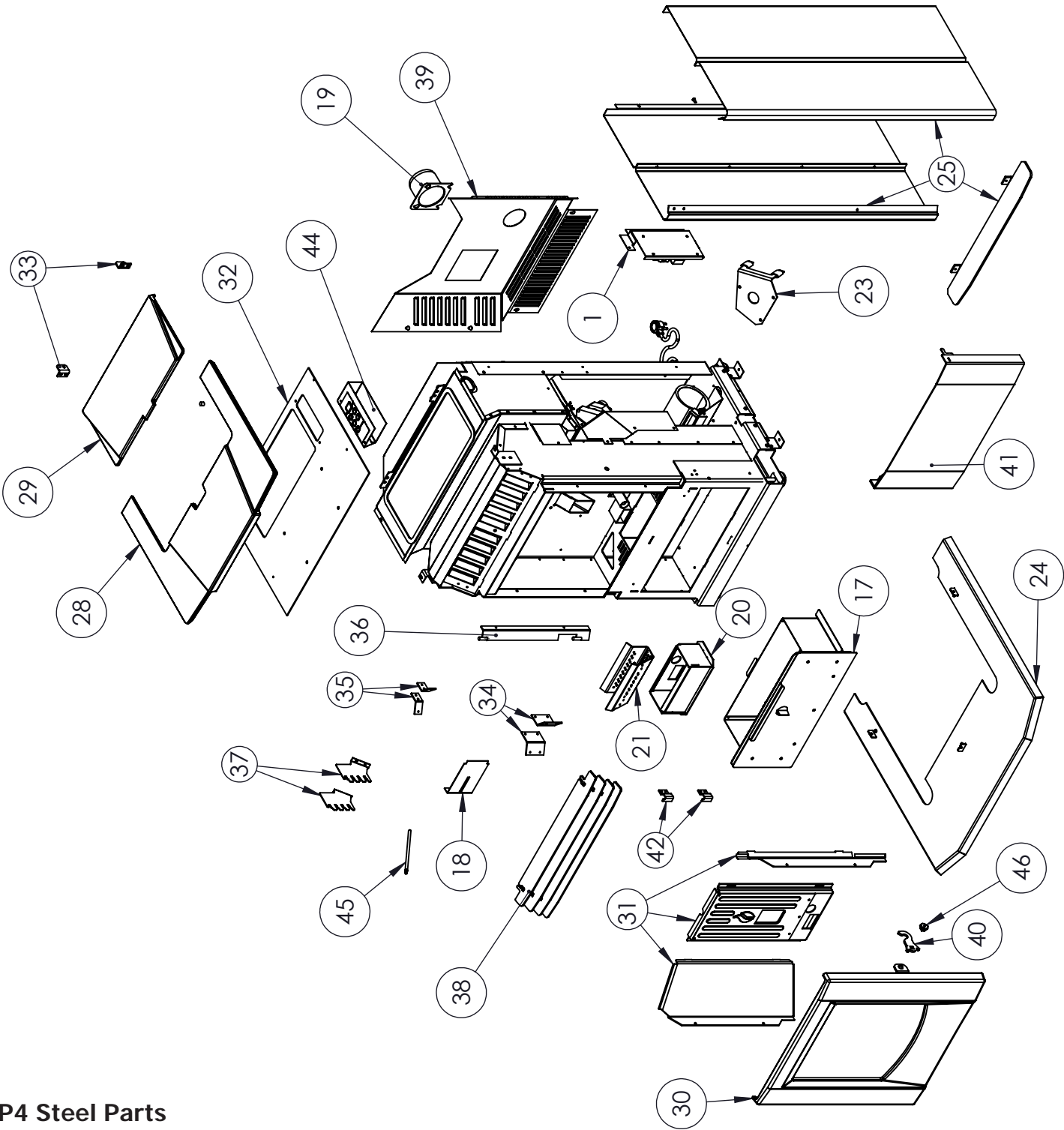

P4 Steel Parts

PARTS DIAGRAM

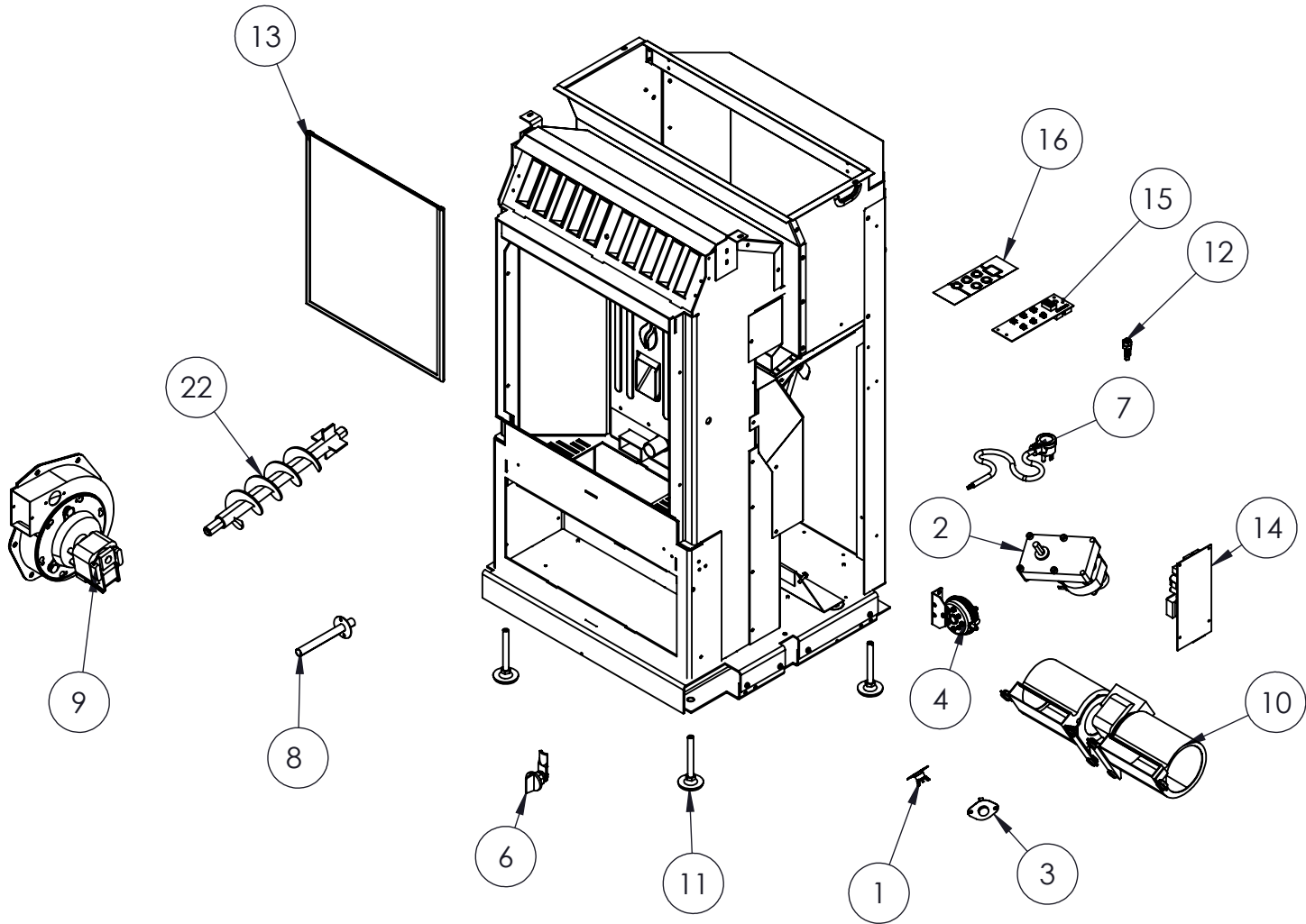

P4 - COMPONENTS

RATING LABEL

C-14680

DO NOT REMOVE THIS LABEL N'ENLEVEZ PAS CETTE ETIQUETTE

Operate this unit only with teh hopper lid closed. Failure to do so may result in emissions of product of combustion from the hopper under certain conditions. Maintain hopper seal in good condition. Do not overfill the hopper.

LIGHTING INSTRUCTIONS:

- Press and release the green on / off button located under hopper lid.
- Set the mode and heat output to the desired setting.

TO TURN THE UNIT OFF:

- Press the green on / off button, when off the -- will be displayed. (Refer to owners manual for detailed instructions)

INSTRUCTIONS POUR L'ALLUMAGE:

- Appuyez et relâchez le vert sur / de bouton situé sous la trémie couvercle.
- Une fois le feu a commence, a regle le production de chaleur au montage desire.

POUR ETENDRE L'UNITE:

- Appuyez sur le vert bouton on / off, quand au large de la -- sera affiche (Referrez-vous au guide de l'utilisateur pou un mode d'emploi detaille).

CAUTION:

Hot while operating. Do not touch, severe burns may result. Keep children, clothing, furniture, gasoline or other flammable vapors away.



See installation and operating instructions accompanying appliance.

Très chaud quand allumé. Ne touchez pas, les brûlures sévères peuvent résulter. Tenez loin des enfants, des vêtements, des meubles, de l'essence ou d'autres fluides produisant des vapeurs inflammables.

Consultez le manuel avec les instructions d'installation et d'opération.

ENVIRO MODEL / MODELE ENVIRO: P4

Input Rating (Les données évaluant): 8,200 to 23,000 BTU/HR (2.4 to 6.7 kW/h)
Listed Room Heater, Pelletized Fuel Type (Appareil de chauffage à granulés certifié)
Suitable For Mobile Home Installation (Accepté pour l'installation dans une maison mobile, test)
Conforms to (conforme à): ASTM E1509-12. Certified to (agréé): UL 1482-1998 / ULC S627-00 / UL C-8628-M93.
This pellet appliance has been tested and listed for use in manufactured homes in accordance with Oregon Administration Rules 814-23-900 through 814-23-909. Install and use only in accordance with the Manufacturer's installation and operating instructions. Contact local building or fire officials about restrictions and installation inspectors for precautions required for passing a chimney through a combustible wall or ceiling. Electrical rating: 120 volts, 60 Hz, 3.3 Amps. Route cord away from the heater / Cet appareil a été testé et certifié pour utilisation dans les maisons mobiles en accord avec les "Règles Administratives de l'Oregon 814-23-900 à 814-23-909". Installez et utilisez cet appareil uniquement selon les instructions d'installation. Contactez les codes de bâtiment locaux et les autorités locales de votre quartier concernant les restrictions et les inspections d'installation. Consultez les codes de bâtiment locaux et les instructions du fabricant pour les précautions à prendre lorsque une cheminée doit être installée au travers un mur ou un plafond combustible. CLASSEMENT ELECTRIQUE : 120 Volts, 60 Hz, 3.3 Amps. Placez le câble électrique loin de la chaleur.
For use with pelletized solid fuels only. Operate only with viewing door and ash removal door closed. Only replace glass with ceramic glass. Components required for installation: a 3 inch (75 mm) or 4inches (100 mm) listed PL vent complete with components. Hearth mount installations; a listed single wall chimney liner may be used.
Pour l'usage avec les combustibles sous forme de boulets uniquement. Fonctionner seulement avec la vue de porte et la porte d'enlèvement de cendre ont fermé. Seulement remplacer le verre avec le verre de céramique. Les composants ont exigé pour l'installation : 3 pouce (75 mm) ou 4 pouce (100 mm) a énuméré le conduit de PL complète avec les composants. Les installations de mont de foyer ; un paquebot de cheminée de mur de seul énuméré peut être utilisé.

CAUTION: Moving Parts May Cause Injury. Do Not Operate Unit With Rear Grill Removed or Cabinet Sides Removed.

ATTENTION: Pièces en mouvement peut causer des blessures. Ne pas l'appareil avec grille arrière supprimé ou Sides Cabinet supprimé.

CAUTION: Hot Parts. Do Not Operate With Rear Grill Removed or Cabinet Sides

ATTENTION: Les pièces chaudes. Ne pas utiliser avec grille arrière supprimé ou Sides

DANGER: Risk of Electric Shock. Disconnect Power Before Servicing. Refer to Owners manual for Electrical and Wiring Connection Diagrams.

DANGER: Risque de choc électrique. Débrancher l'alimentation avant l'entretien. Reportez-vous au manuel Propriétaires de Schémas de raccordement électrique et de câblage

CAUTION: Operate this unit only with the hopper lid closed. Failure to do so may result in emissions of product of combustion from the hopper under certain conditions maintain hopper seal in good condition. Do not overfill the hopper.

ATTENTION: Utilisez cet appareil uniquement avec le couvercle de la trémie fermée. Ne pas le faire peut entraîner émissions de produit de la combustion de la trémie sous certaines conditions maintenance joint trémie en bon état. Ne pas trop remplir la trémie.



Intertek

Certified for use in Canada & USA
Certifié pour installation au
Canada et aux Etats-Unis.

INSTALLED AS A FREESTANDING STOVE MODEL (FS) / A INSTALLER COMME UN MODELE SUR-PIED DE POELE

Minimum clearances to combustible materials: conventional or mobile home./
Les dégagements minimums aux matériaux combustibles; la maison
conventionnelle ou mobile.

A	Sidewall to Unit (Du mur de côté à l'appareil)	6" (152 mm)
B	Backwall to Unit (Du mur de derrière à l'appareil)	3" (76 mm)
C	Corner to Unit (Du coin à l'appareil)	3" (76 mm)
D	From door opening of unit to edge of floor protection (De la porte ouvrant au devant de protection de plancher) NOTE: Combustible material must be protected by a non-combustible material. Voiding must be protected by a non-combustible material. (Un plancher combustible doit être protégé par un matériel incombustible. La largeur 27" (686 mm) par la profondeur 34" (864mm).)	6" (152 mm)
	Minimum Alcove Width (La largeur minimum de l'alcove)	48" (1219 mm)
	Minimum Alcove Height (La hauteur minimum de l'alcove)	48" (1219 mm)
	Maximum Alcove Depth (La profondeur maximum de l'alcove)	48" (1219 mm)

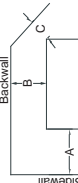

MANUFACTURED BY / FABRIQUE PAR:
SHERWOOD INDUSTRIES LTD.
VICTORIA BC CANADA

DATE OF MANUFACTURE / DATE DE FABRICATION:

F M A M J J A S O N D 2015 2016 2017

U.S. ENVIRONMENTAL PROTECTION AGENCY Certified to comply with 2015 particulate emission standards. Not approved for sale after May 15, 2020. This pellet heater needs periodic inspection and repair for proper operation. Consult the owner's manual for further information. It is against federal regulations to operate this heater in a manner inconsistent with the operating instructions in the owner's manual. This heater meets the 2015 U.S. Environmental Protection Agency's pellet emission limits for pellet units sold after May 15, 2015. Under specific test conditions this heater has been shown to have a particulate emission level of 1.3 g/hr.

ENVIRONMENTAL PROTECTION AGENCY US conforme aux normes 2015 d'émission de particules. Non approuvé pour la vente après le 15 mai à 2020. Ce poêle à granulés besoins inspection périodique et la réparation pour un fonctionnement correct. Consultez le manuel d'owner's pour plus d'informations. Il est contre les règlements fédéraux pour exploiter cette pastille chauffée d'une manière incompatible avec les instructions de l'Environmental Protection Agency des Etats-Unis 2015 pour les unités de pellets vendus après le 15 mai 2015. Dans des conditions de test spécifiques, ce poêle a été montré pour avoir un niveau d'émission de particules de 1,3 g/h.



Warranty for Enviro Pellet Products

Sherwood Industries Ltd. ("Sherwood") hereby warrants, subject to the terms and conditions herein set forth, this product against defects in material and workmanship during the specified warranty period starting from the date of original purchase at retail. In the event of a defect of material or workmanship during the specified warranty period, Sherwood reserves the right to make repairs or to assess the replacement of a defective product at Sherwood's factory. The shipping costs are to be paid by the consumer. All warranties by Sherwood are set forth herein and no claim shall be made against Sherwood on any oral warranty or representation.

Conditions

- A completed warranty registration must be submitted to Sherwood within 90 days of original purchase via the online warranty registration page or via the mail-in warranty registration card provided. Have the installer fill in the installation data sheet in the back of the manual for warranty and future reference.
- This warranty applies only to the original owner in the original location from date of install.
- The unit must have been properly installed by a qualified technician or installer, and must meet all local and national building code requirements.
- The warranty does not cover removal and re-installation costs.
- Sherwood Industries Ltd. reserves the right to make changes without notice.
- Sherwood Industries Ltd. and its employees or representatives will not assume any damages, either directly or indirectly caused by improper usage, operation, installation, servicing or maintenance of this appliance.
- A proof of original purchase must be provided by you or the dealer including serial number.

Exclusions

An expanded list of exclusions is available at www.enviro.com/help/warranty.html

This warranty does not cover:

- Damage as a result of improper usage or abuse.
- Damage caused from over-firing due to incorrect setup or tampering.
- Damage caused by incorrect installation.

To the Dealer

- Provide name, address and telephone number of purchaser and date of purchase.
- Provide date of purchase. Name of installer and dealer. Serial number of the appliance. Nature of complaint, defects or malfunction, description and part # of any parts replaced.
- Pictures or return of damaged or defective product may be required.

To the Distributor

- Sign and verify that work and information are correct.

Sherwood Industries Ltd.

6782 Oldfield Road, Victoria, BC . Canada V8M 2A3
 Online warranty registration: www.enviro.com/warranty/

Category	One Year	Two Year	Limited Lifetime (7yr)
Parts ¹ (unit serial number required)		✓	
Firebox Brick Panels (Cast)		✓	
Firebox			✓
Heat Exchanger			✓
Burn Pot			✓
Burn Pot Liner		✓	
Firebox Liner Panels w/Insulation			✓
Ceramic Glass ²	✓		
Pedestal / Legs (excluding finish)			✓
Surround Panels (excluding finish)			✓
Exterior Panels (excluding finish)			Up to 5 years
Electrical Components		✓	
Steel Brick Liner (Metal)	✓		
Exterior Surface Finishing ³	✓		
Labour	✓		

¹ Whereas warranty has expired, replacement parts will be warranted for 90 days from part purchase date. Labour not included. Unit serial number required.

² Glass is covered for thermal breakage. Photos of box, inside of door, and unit serial # must be supplied for breakage due to shipping.

³ Exterior Surface finishing covers Plating, Enamel or Paint and excludes colour changes, chipping, and fingerprints.

Gaskets not covered by Warranty.

Travel costs not included.

Cast Agitator: 1 year for pellet. Not covered when burning alternative fuels. (Cast agitators are a consumable item)

INSTALLATION DATA SHEET

The following information must be recorded by the installer for warranty purposes and future reference.

NAME OF OWNER: _____

ADDRESS: _____

PHONE: _____

NAME OF DEALER: _____

ADDRESS: _____

PHONE: _____

MODEL: _____

SERIAL NUMBER: _____

DATE OF PURCHASE: _____ (dd/mm/yyyy)

DATE OF INSTALLATION: _____(dd/mm/yyyy)

MAGNEHELIC AT INSTALL: _____

INSTALLER'S SIGNATURE: _____

NAME OF INSTALLER: _____

ADDRESS: _____

PHONE: _____

NOTES

NOTES

NOTES



MANUFACTURED BY:
SHERWOOD INDUSTRIES LTD.
6782 OLDFIELD RD. SAANICHTON, BC, CANADA V8M 2A3
www.enviro.com
March 20, 2017
C-14675