



SHERWOOD INDUSTRIES IS AN ENVIRONMENTALLY RESPONSIBLE COMPANY. THIS MANUAL IS PRINTED ON RECYCLED PAPER.

PLEASE KEEP THESE INSTRUCTIONS FOR FUTURE REFERENCE



PELLET STOVE

EF4

Freestanding and Fireplace Insert

TECHNICAL MANUAL



PLEASE READ THIS ENTIRE MANUAL BEFORE INSTALLATION AND USE OF THIS PELLET BURNING ROOM HEATER. FAILURE TO FOLLOW THESE INSTRUCTIONS COULD RESULT IN PROPERTY DAMAGE, BODILY INJURY, OR EVEN DEATH.

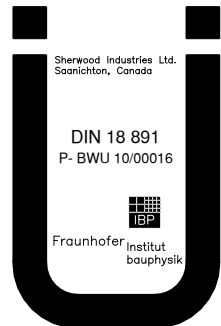

Contact your building or fire officials about restrictions and installation inspection requirements in your area.

TABLE OF CONTENTS

Introduction.....	3
Rating Label Location.....	3
Important Safety Data.....	3
Safety Warnings And Recommendations.....	3
Installation.....	5
Deciding Where to Locate your Pellet Appliance.....	5
Removing Pellet Stove From Pallet.....	5
Dimensions - Freestanding.....	6
Dimensions - Fireplace Insert.....	6
Clearances to Combustibles - Freestanding.....	7
Clearances to Combustibles - Fireplace Insert.....	7
Pedestal Installation - Freestanding.....	8
Pedestal Installation - Fireplace Insert.....	8
Vent Termination Requirements.....	9
Outside Fresh-Air Connection.....	10
Exhaust And Fresh Air Intake Locations.....	10
Mobile Home Installation - Freestanding.....	11
Corner Through Wall Installation - Freestanding.....	11
Horizontal Exhaust Through Wall Installation - Freestanding.....	12
Through Wall With Vertical Rise and Horizontal Termination Installation - Freestanding.....	13
Inside Vertical Installations - Freestanding.....	14
Outside Vertical Installations - Freestanding.....	14
Hearth Mount Installation - Freestanding.....	15
Masonry Fireplace Installation - Fireplace Insert.....	16
Slider/Damper Setting.....	18
Installation of Control Panel in The Insert Surround Panels.....	18
Assembling The Insert Surround Panels.....	19
Installation and Removal of Insert Surround Panels.....	19
Installation of Door A.....	20
Troubleshooting.....	21
Wiring Diagram.....	25
Part List.....	26
Part List -Options.....	28
Part Diagram - Components.....	29
Part Diagram - Steel.....	30
Warranty.....	31
Installation Data Sheet.....	32

INTRODUCTION

RATING LABEL LOCATION:

Freestanding: The rating label is located on the inside of the hopper lid.

Insert: The rating label is located on the hopper cover.

IMPORTANT SAFETY DATA:

Please read this entire Owner's Manual before installing or operating this ENVIRO Pellet Stove. Failure to follow these instructions may result in property damage, bodily injury or even death. Contact your local building or fire official to obtain a permit and any information on installation restrictions and inspection requirements for your area.

To prevent the possibility of a fire, ensure that the appliance is properly installed by adhering to the installation instructions. An ENVIRO dealer will be happy to assist you in obtaining information with regards to your local building codes and installation restrictions.

Be sure to maintain the structural integrity of the home when passing a vent through walls, ceilings, or roofs.

The stove's exhaust system works with negative combustion chamber pressure and a slightly positive chimney pressure. It is very important to ensure that the exhaust system be sealed and airtight. The ash pan and viewing door must be locked securely for proper and safe operation of the pellet stove.

Do not burn with insufficient combustion air. A periodic check is recommended to ensure proper combustion air is admitted to the combustion chamber. Setting the proper combustion air is achieved by adjusting the slider damper located on the left side of the stove.

When installing the stove in a mobile home, it must be electrically grounded to the steel chassis of the home and bolted to the floor. Make sure that the structural integrity of the home is maintained and all construction meets local building codes.

Minor soot or creosote may accumulate when the stove is operated under incorrect conditions such as an extremely rich burn (black tipped, lazy orange flames).

If you have any questions with regard to your stove or the above-mentioned information, please feel free to contact your local dealer for further clarification and comments.

SAFETY WARNINGS AND RECOMMENDATIONS:

Caution: Do not connect to any air distribution duct or system.

Do not burn garbage or flammable fluids such as gasoline, naptha or engine oil.

Unit hot while in operation. Keep children, clothing and furniture away. Contact may cause skin burns.

SOOT: Operation of the stove with insufficient combustion air will result in the formation of soot which will collect on the glass, the heat exchanger, the exhaust vent system, and may stain the outside of the house. This is a dangerous situation and is inefficient. Frequently check your stove and adjust the slider/damper as needed to ensure proper combustion. **See: "SLIDER/DAMPER SETTING".**

INTRODUCTION

ELECTRICAL: The use of a surge protected power bar is recommended. The unit must be grounded. The grounded electrical cord should be connected to a standard 220-240 volts (2.17-2.36 Amps), 50 hertz electrical outlet and also must be accessible. If this power cord should become damaged, a replacement power cord must be purchased from the manufacturer or a qualified ENVIRO dealer. Be careful that the electrical cord is not trapped under the appliance and that it is clear of any hot surfaces or sharp edges. This unit's maximum power requirement is 520 watts.

GLASS: Do not abuse the glass by striking or slamming the door. Do not attempt to operate the stove with broken glass. The stove uses ceramic glass. Replacement glass must be purchased from an ENVIRO dealer. Do not attempt to open the door and clean the glass while the unit is in operation or if glass is hot. To clean the glass, use a soft cotton cloth and mild window cleaner, gas or wood stove glass cleaner, or take a damp paper towel and dip into the fly ash. This is a very mild abrasive and will not damage the glass.

FLAMMABLE LIQUIDS: Never use gasoline, gasoline-type lantern fuel, kerosene, charcoal lighter fluid, or similar liquids to start or "freshen up" a fire in the heater. Keep all such liquids well away from the heater while it is in use.

SMOKE DETECTOR: Smoke detectors should be installed and maintained in the structure when installing and operating a pellet burning appliance.

OPERATION: The ash pan and door must be closed securely for proper and safe operation of the pellet stove. Also ensure all gaskets on the door are checked and replaced when necessary.

INSTALLATION: Be sure to maintain the structural integrity of your home when passing a vent through walls, ceilings, or roofs. It is recommended that the unit be secured into its position in order to avoid any displacement.

DO NOT INSTALL A FLUE DAMPER IN THE EXHAUST VENTING SYSTEM OF THIS UNIT.

DO NOT CONNECT THIS UNIT TO A CHIMNEY FLUE SERVING ANOTHER APPLIANCE.

FRESH AIR: Outside Fresh Air connection is optional. Must be connected to all units installed in Mobile and "Air Tight Homes" (R2000) or where required by local codes. Consider all large air moving devices when installing your unit and provide room air accordingly. Limited air for combustion may result in poor performance, smoking and other side effects of poor combustion.

If you have any questions with regards to your stove or the above-mentioned information, please feel free to contact your local dealer for further clarification and comments.

SINCE SHERWOOD INDUSTRIES LTD. HAS NO CONTROL OVER THE INSTALLATION OF YOUR STOVE, SHERWOOD INDUSTRIES LTD. GRANTS NO WARRANTY IMPLIED OR STATED FOR THE INSTALLATION OR MAINTENANCE OF YOUR STOVE. THEREFORE, SHERWOOD INDUSTRIES LTD. ASSUMES NO RESPONSIBILITY FOR ANY CONSEQUENTIAL DAMAGE(S).

SAVE THIS INSTRUCTION MANUAL FOR FUTURE REFERENCE

INSTALLATION

DECIDING WHERE TO LOCATE YOUR PELLET APPLIANCE:

1. Check clearances to combustibles.
2. Do not obtain combustion air from an attic, garage or any unventilated space. Combustion air may be obtained from a ventilated crawlspace.
3. Do not install the stove in a bedroom.
4. You can vent the stove through an exterior wall behind the unit or connect it to an existing masonry or metal chimney (must be lined if the chimney is over 6" (15 cm) diameter, or over 28 inches² (180 cm²) cross sectional area). An interior vent can be used with approved pipe passing through the ceiling and roof.
5. Locate the stove in a large and open room that is centrally located in the house. This will optimize heat circulation.
6. The power cord is 8 feet (2.43 m) long and may require a grounded extension cord to reach the nearest electrical outlet.

REMOVING PELLET STOVE FROM PALLET:

To remove your new stove from its pallet, open the left and right side panels. There are two (2) wood screws that are holding the bottom of the stove to the pallet. Remove the screws. Close the side panels. See "PEDESTAL INSTALLATION - FREESTANDING" or "PEDESTAL INSTALLATION - INSERT" to install the pedestal.

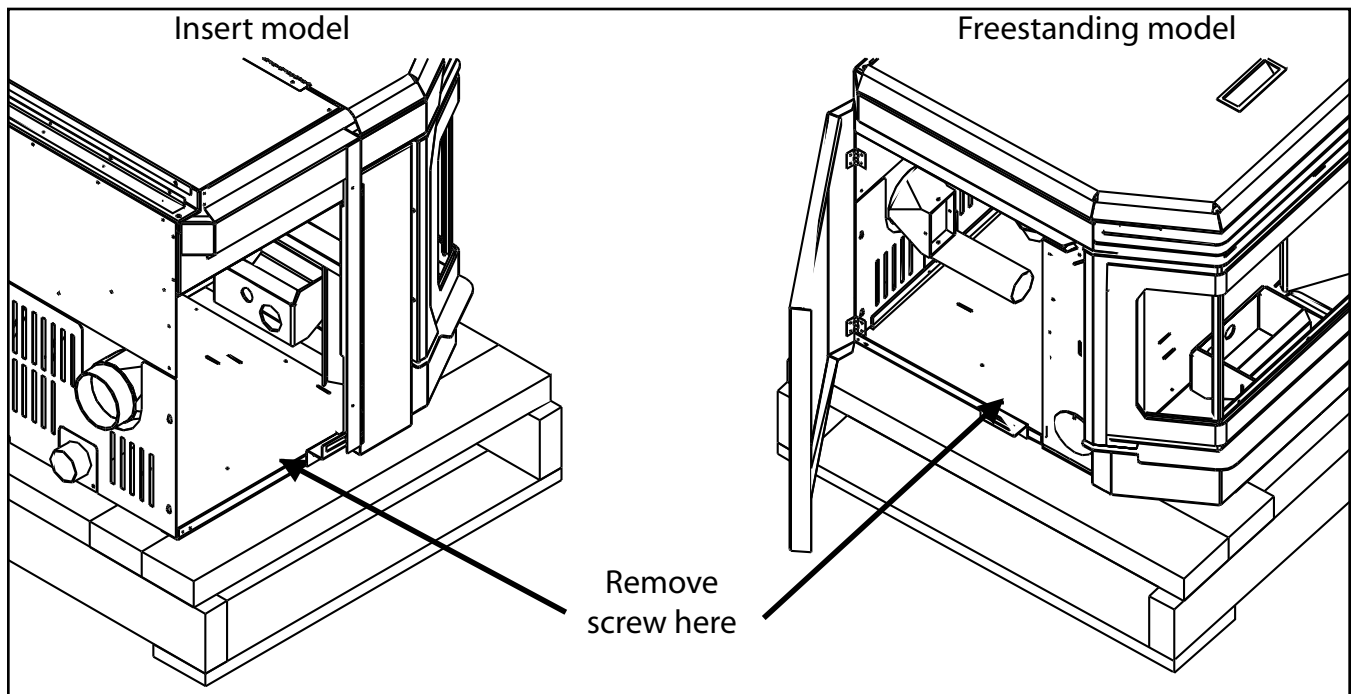

Figure 1: Screws to take out to remove stove from pallet.

INSTALLATION

DIMENSIONS - FREESTANDING:

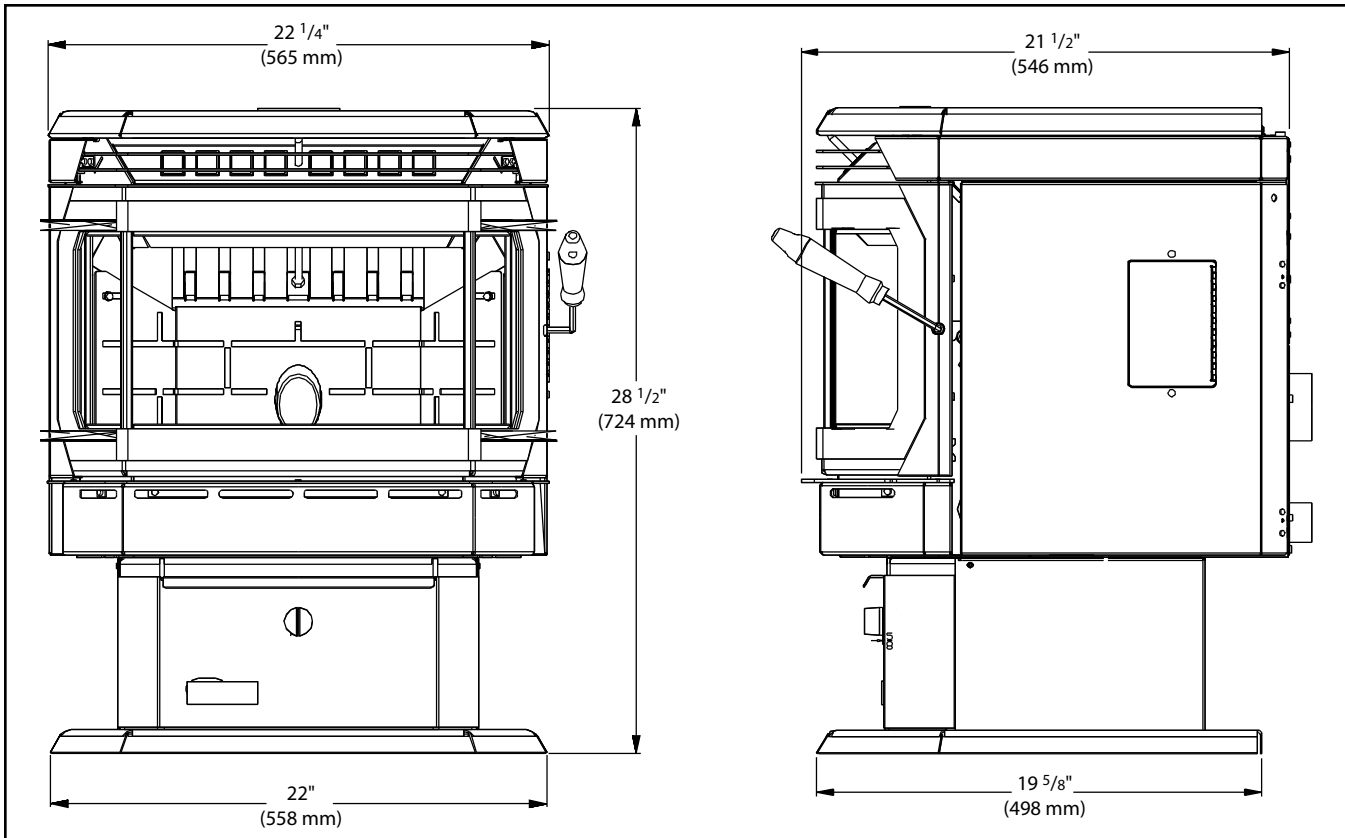

Figure 2: Dimensions of EF4 Freestanding.

DIMENSIONS - FIREPLACE INSERT:

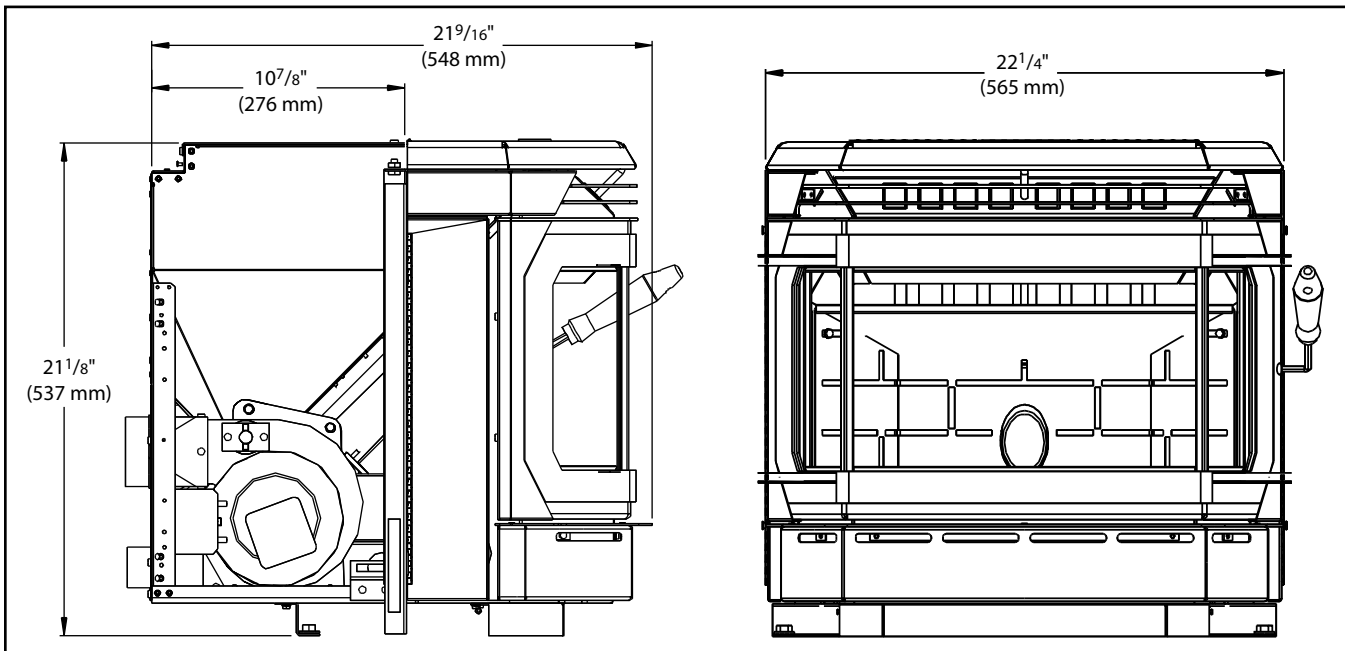

Figure 3: Dimensions of EF4 Fireplace Insert.

INSTALLATION

CLEARANCES TO COMBUSTIBLES - FREESTANDING:

When installing this unit on a combustible floor (eg. wood linoleum) a non-combustible hearth pad must be under the unit. The pad must extend at least the width of the appliance [22" (558 mm)] and at least the depth of the appliance plus 6" (150 mm) in front of the appliance [27 1/2" (699 mm)].

Side wall to unit	- 6 inches	(15 cm)
Back wall to unit	- 2 inches	(5 cm)
Corner to unit	- 2 inches	(5 cm)
Door front to edge of floor protection	- 6 inches	(15 cm)

These dimensions are minimum clearances but it is recommended that you ensure sufficient room for servicing, routine cleaning and maintenance.

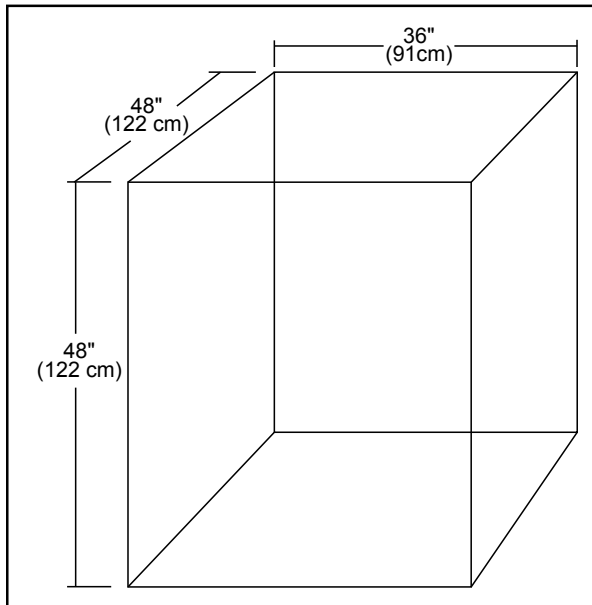

Figure 5: EF4 Freestanding Minimum Alcove Size.

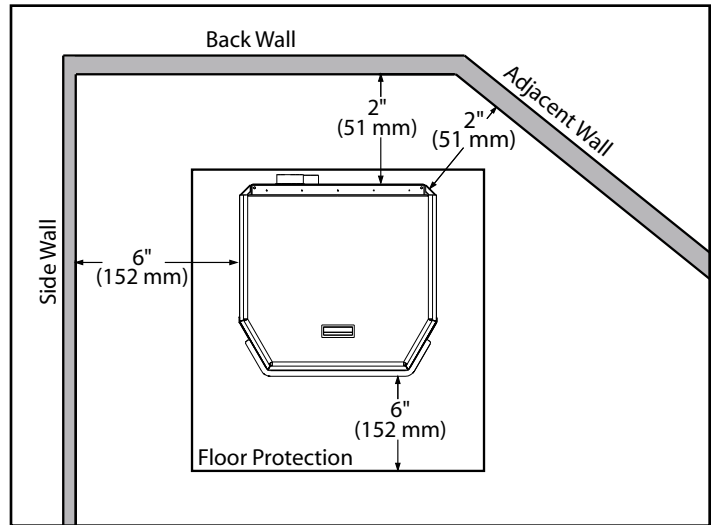

Figure 4: EF4 Freestanding Clearance to Combustibles.

Minimum Alcove width	- 36 inches	(91 cm)
Minimum Alcove height	- 48 inches	(122 cm)
Maximum Alcove depth	- 48 inches	(122 cm)

CLEARANCES TO COMBUSTIBLES - FIREPLACE INSERT:

Side wall to unit	- 9 inches	(22.9 cm)
Mantel projection	- 10 inches	(25.4 cm)
Mantel to top of unit	- 8 inches	(20.3 cm)
Facing on masonry fireplace edge	- 9 inches	(22.9 cm)

Minimum solid fuel burning fireplace opening:		
Height	- 21 1/8"	(53.7 cm)
Width	- 22"	(58.9 cm)
Depth	- 21 1/2"	(54.6 cm)

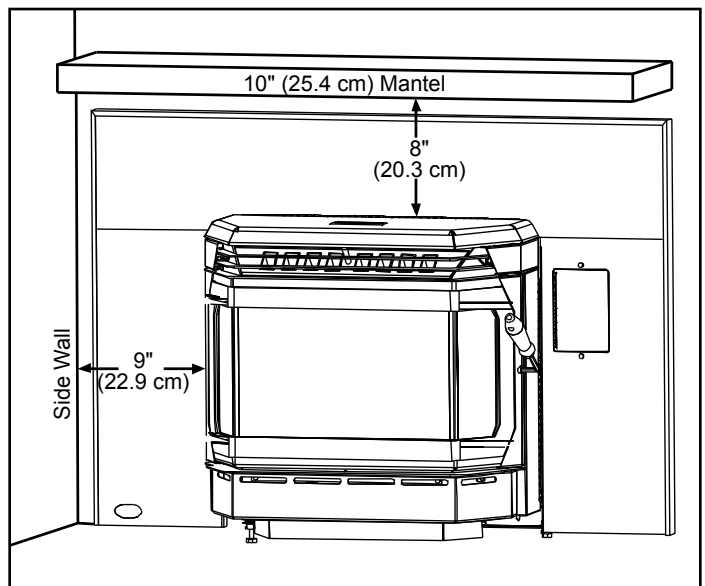

Figure 6: EF4 Fireplace Insert Clearance to Combustibles.

INSTALLATION

PEDESTAL INSTALLATION - FREESTANDING:

The freestanding model comes with a pedestal that has to be attached prior to installation:

- Remove the pedestal from the box
- Remove the unit from the box
- Place the unit on its back on the pallet.
- Back the four (4) screws in the base off three (3) to four (4) full turns.
- Align the keyholes in the pedestal with the screws, lock into place.
- Secure the two (2) pieces by tightening the four (4) screws from the inside of the pedestal.

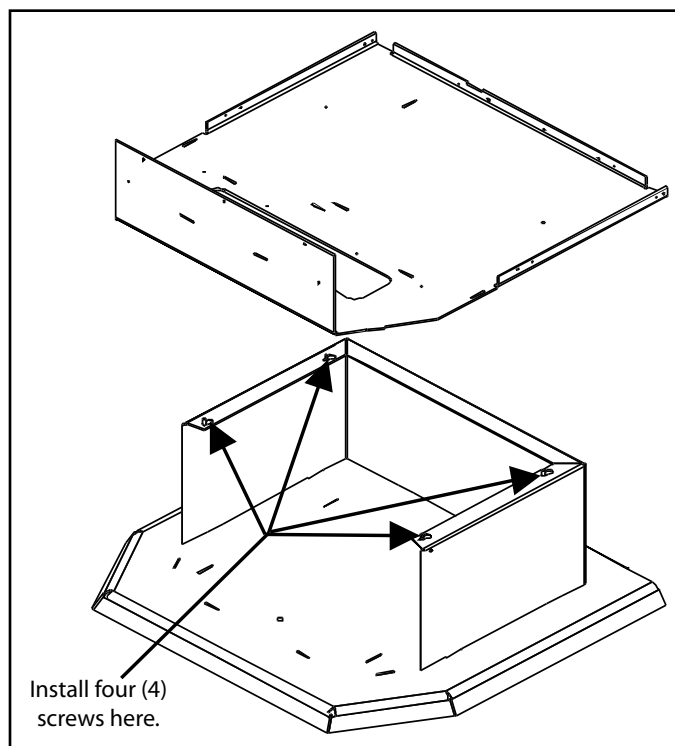

Figure 7: Freestanding Pedestal.

PEDESTAL INSTALLATION - FIREPLACE INSERT:

The pedestal for the fireplace insert is packaged in the hopper of the appliance. Secure the leveling (Z-style) bracket onto the back two (2) pedestal mounting screws with the inserted nuts facing up. Insert leveling legs into the nuts on the Z bracket if necessary.

Place the front portion of the pedestal into the front pedestal screws; there are two slots in the pedestal that fit over these screws. Finish securing the pedestal using the four (4) T-20 Torx screws provided. This will cover and seal the ash pan hole in the bottom of the firebox inside the appliance.

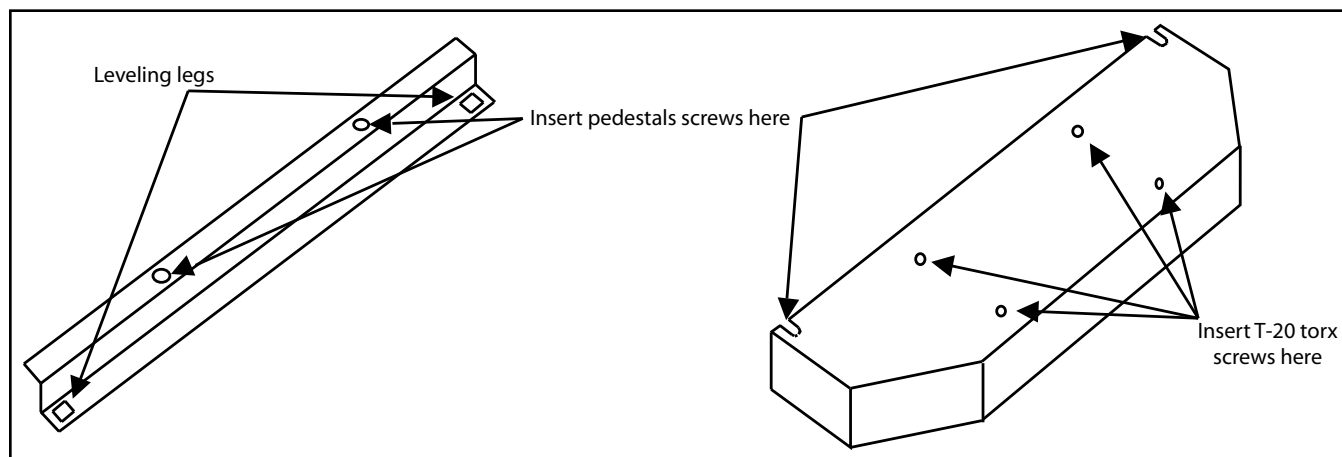

Figure 8: Fireplace Insert Pedestal and Leveling Legs.

INSTALLATION

VENT TERMINATION REQUIREMENTS:

IT IS RECOMMENDED THAT YOUR PELLET STOVE BE INSTALLED BY AN AUTHORIZED DEALER/INSTALLER.

Table 1: Use in conjunction with Figure 9 for allowable exterior vent termination locations.

Letter	Minimum Clearance	Description
A	24 in (61 cm)	Above grass, top of plants, wood, or any other combustible materials.
B	48 in (122 cm)	From beside/below any door or window that may be opened.
C	24 in (61 cm)	From above any door or window that may be opened.
D	24 in (61 cm)	To any adjacent building, fences and protruding parts of the structure.
E	24 in (61 cm)	Below any eave or roof overhang
F	12 in (30 cm)	To outside corner.
G	12 in (30 cm)	To inside corner, combustible wall (vertical and horizontal terminations).
H	3 ft (91 cm) within a height of 15 ft (4.5 m) above the meter/regulator assembly	To each side of center line extended above natural gas or propane meter/regulator assembly or mechanical vent.
I	3 ft (91 cm)	From any forced air intake of other appliance
J	12 in (30 cm)	Clearance to non-mechanical air supply inlet to building, or the combustion air inlet to any appliance.
K	24 in (61 cm)	Clearance above roof line for vertical terminations.
L	7 ft (2.13 m)	Clearance above paved sidewalk or paved driveway located on public property.

1. Do not terminate the vent in any enclosed or semi-enclosed areas such as a carport, garage, attic, crawlspace, narrow walkway, closely fenced area, under a sundeck or porch, or any location that can build up a concentration of fumes such as stairwells, covered breezeway, etc.

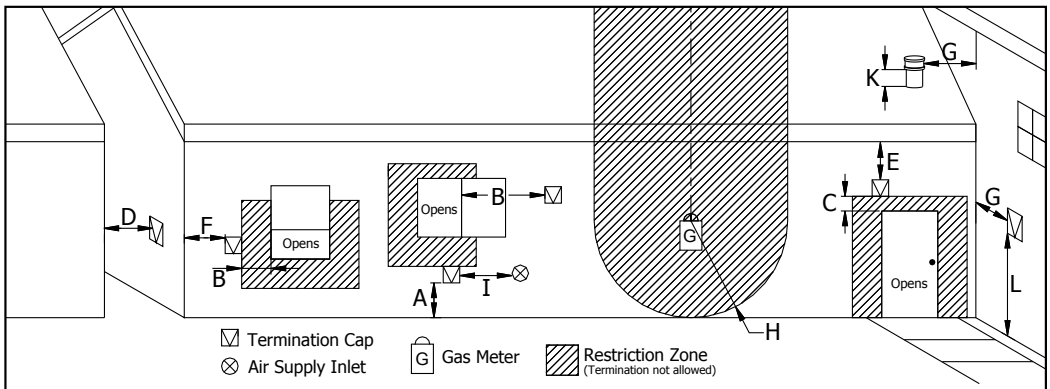

Figure 9: Use in conjunction with Table 1 for allowable exterior vent termination locations.

- Vent surfaces can become hot enough to cause burns if touched by children. Non-combustible shielding or guards may be required.
- Termination must exhaust above the inlet elevation. It is recommended that at least five feet of vertical pipe be installed outside when the appliance is vented directly through a wall, to create some natural draft to prevent the possibility of smoke or odor during appliance shut down or power failure. This will keep exhaust from causing a nuisance or hazard from exposing people or shrubs to high temperatures. In any case, the safest and preferred venting method is to extend the vent through the roof vertically.
- Distance from the bottom of the termination and grade is 12" (30 cm) minimum. This is conditional upon the plants and nature of grade surface. The exhaust gases are hot enough to ignite grass, plants and shrubs located in the vicinity of termination. The grade surface must not be lawn.
- If the unit is incorrectly vented or the air to fuel mixture is out of balance, a slight discoloration of the exterior of the house might occur. Since these factors are beyond the control of Sherwood Industries Ltd, we grant no guarantee against such incidents.
- When installing an FPI the chimney must be fully lined. Unless the chimney's inside diameter is less than 6" (15 cm) around or has a cross section area of 28 inches² (180.6 cm²), we strongly recommend lining all masonry chimneys.

NOTE: Venting terminals shall not be recessed into walls or siding.

INSTALLATION

OUTSIDE FRESH-AIR CONNECTION:

Outside fresh air is mandatory when installing this unit in airtight homes and mobile homes.

When connecting to an outside fresh air source, do not use plastic or combustible pipe. Only 1 5/8" minimum (42 mm) ID (inside diameter) steel, aluminum or copper pipe should be used. It is recommended, when you are installing a fresh air system, to keep the number of bends in the pipe to a minimum.

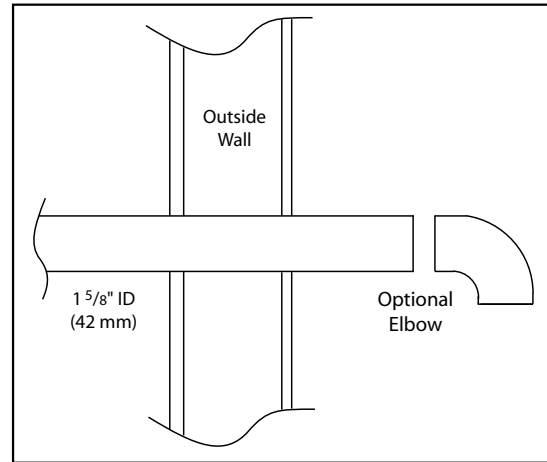

Figure 10: Outside Air Connection.

EXHAUST AND FRESH AIR INTAKE LOCATIONS:

EXHAUST

Base to center of flue
Side to center of flue
Center of unit to center of flue

Freestanding

15 1/4" (38.8 cm)
5 7/8" (14.8 cm)
5 3/16" (13.2 cm)

Insert

7 7/8" (20.0 cm)
5 3/4" (14.6 cm)
5 3/16" (13.2 cm)

FRESH AIR INTAKE.

Base to center of intake
Side to center of intake
Center of unit to center of flue

10 1/8" (25.9 cm)
8" (20.2 cm)
3 1/16" (7.8 cm)

2 15/16" (7.4 cm)
8 1/16" (20.5 cm)
3 1/16" (7.8 cm)

INSTALL VENT AT CLEARANCES SPECIFIED BY THE VENTING MANUFACTURER

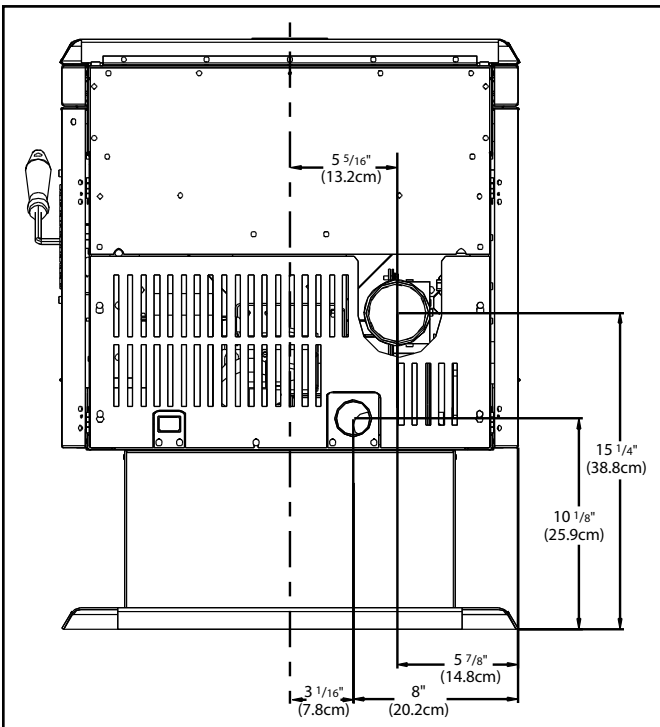

Figure 11: EF4 Freestanding Inlet and Outlet Location.

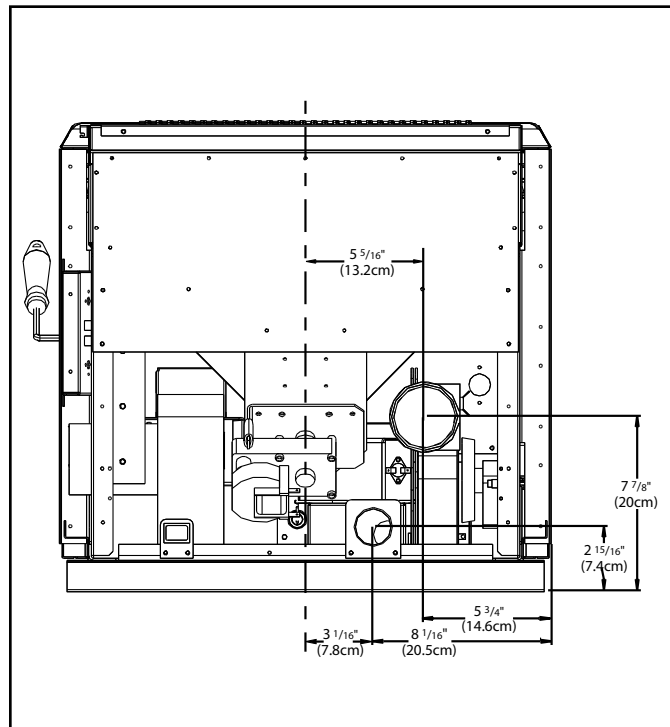

Figure 12: EF4 Fireplace Insert Inlet and Outlet Location.

INSTALLATION

MOBILE HOME INSTALLATION - FREESTANDING:

- Secure the heater to the floor using the two (2) holes in the pedestal.
- Ensure the unit is electrically grounded to the chassis of your home (permanently).
- Do not install in a room people sleep in.
- Outside fresh air is mandatory. Secure outside air connections directly to fresh air intake pipe and secure with three (3) screws evenly spaced.

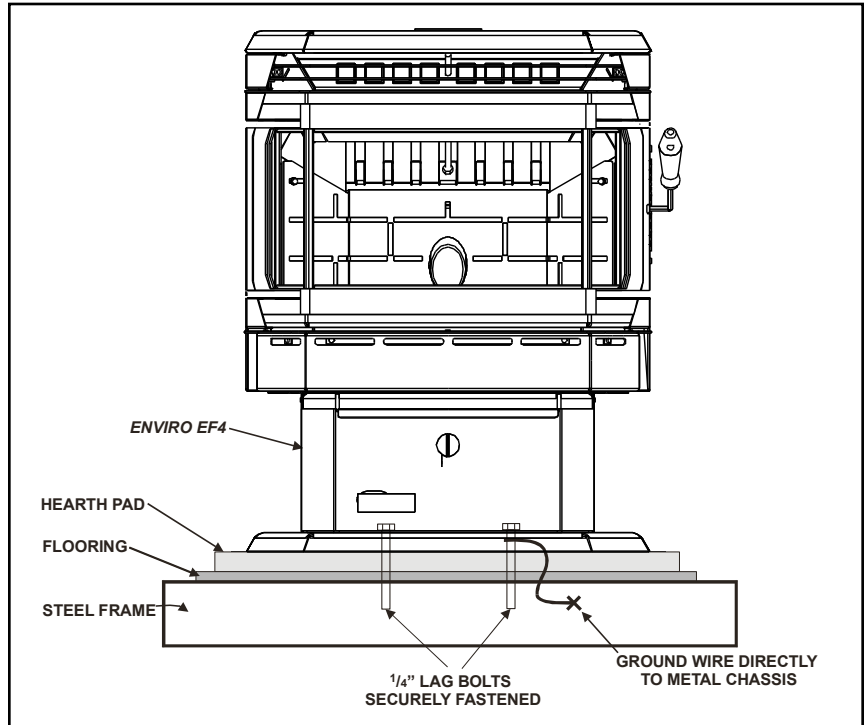

Figure 13: Mobile home installation.

CAUTION: THE STRUCTURAL INTEGRITY OF THE MANUFACTURED HOME FLOOR, WALL AND CEILING/ROOF MUST BE MAINTAINED.

CORNER THROUGH WALL INSTALLATION - FREESTANDING:

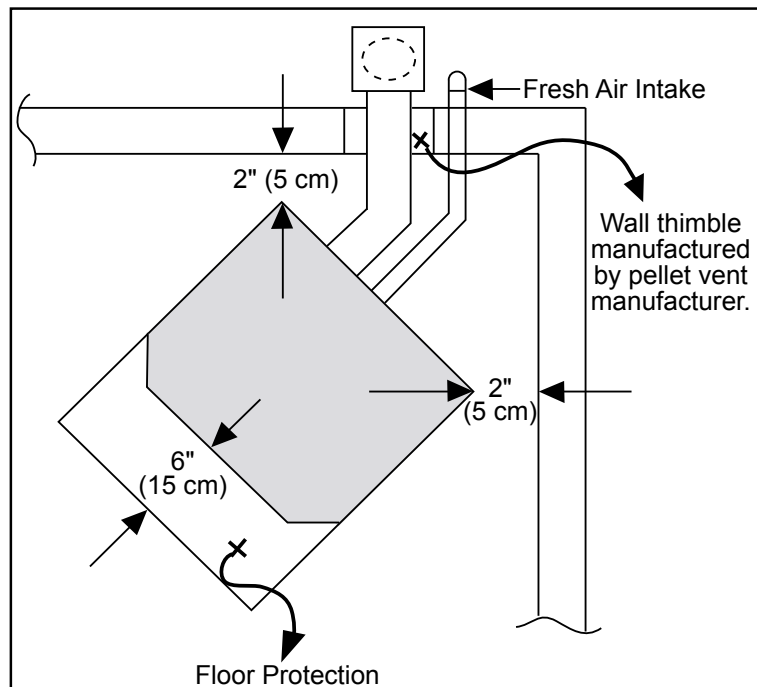

Figure 14: Corner Installation.

INSTALLATION

HORIZONTAL EXHAUST THROUGH WALL INSTALLATION - FREESTANDING:

Vent installation: install vent at clearances specified by the vent manufacturer.

A chimney connector shall not pass through an attic or roof space, closet or similar concealed spaces, or a floor, or ceiling. Where passage through a wall or partition of combustible construction is desired, the installation shall conform to CAN/CSA-B365 Installation Code for Solid-Fuel-Burning Appliances and Equipment. Only use venting of L or PL type with an inside diameter of 3 or 4 inches (7.6 or 10.1 cm).

1. Choose a location for your stove that meets the requirements stated in this manual and allows installation with the least amount of interference to house framing, plumbing, wiring, etc.
2. Install a non-combustible hearth pad (where necessary).

3. Place the appliance 15" (37.5 cm) away from the wall. If the stove is to be set on a hearth pad, set the unit on it.

4. Locate the center of the exhaust pipe on the stove. Extend that line to the wall. Once you have located the center point on the wall, refer to pellet vent manufacturer installation instructions for correct hole size and clearance to combustibles.

5. Install the wall thimble as per the instructions written on the thimble. Maintain an effective vapour barrier in accordance with local building codes.

6. Install a length of 3" (76 mm) or 4" (101 mm) vent pipe into the wall thimble. The pipe should install easily into the thimble.

7. Install the fresh air intake (see OUTSIDE FRESH AIR CONNECTION).

8. Connect the exhaust vent pipe to the exhaust pipe on the stove. Seal the connection with high temperature silicone.

9. Push the stove straight back, leaving a minimum of 2" (5 cm) clearance from the back of the stove to the wall. Seal the vent pipe to the thimble with high temperature silicone.

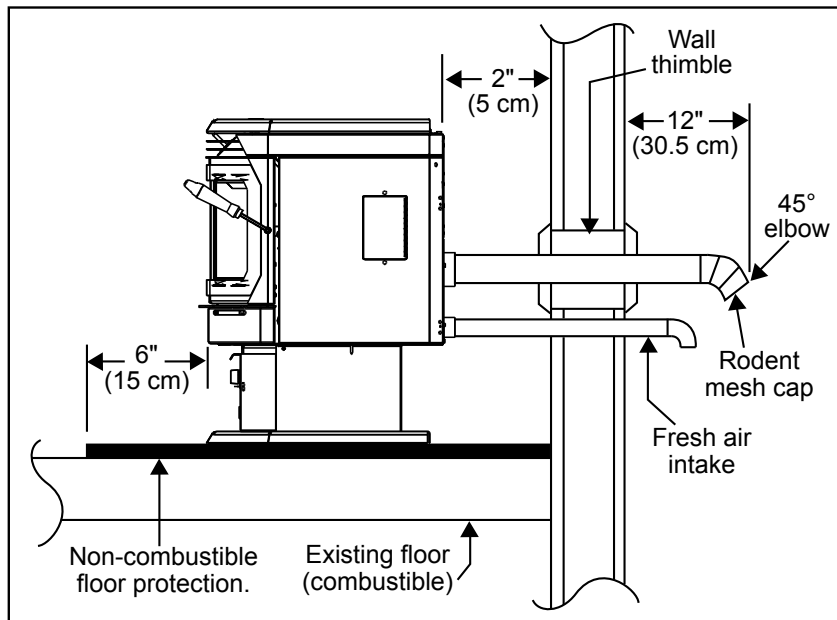

Figure 15: Straight through wall Installation.

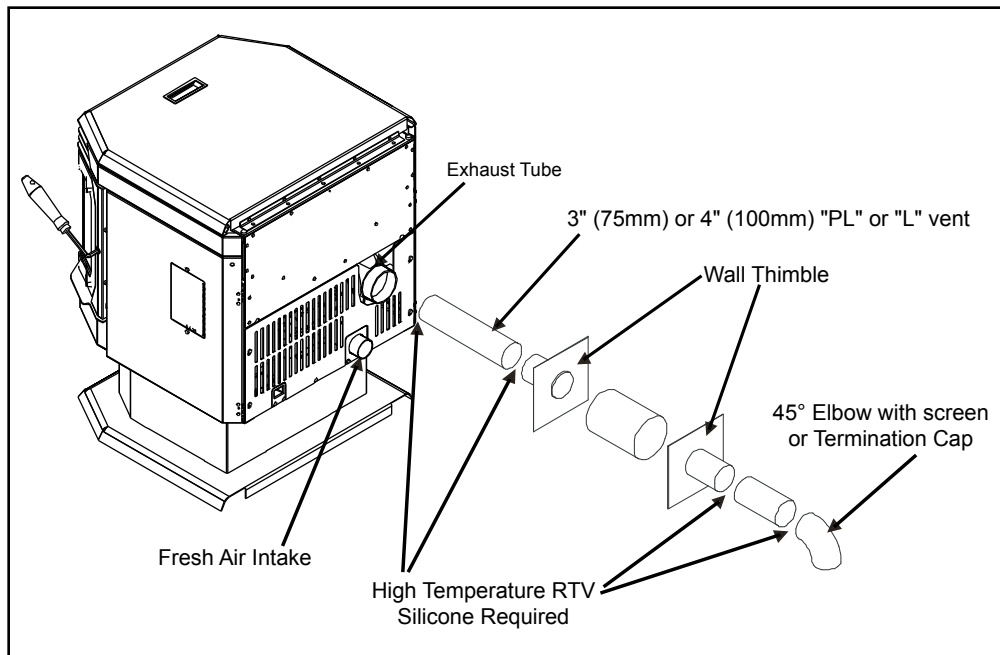

Figure 16: Venting to use with straight through wall Installation.

INSTALLATION

10. The pipe must extend at least 12" (30 cm) away from the building. If necessary, bring another length of pipe (PL type) to the outside of the home to connect to the first section. Do not forget to place high temperature silicone around the pipe that passes through the thimble.
11. Install a vertical pipe, or if all requirements for direct venting are met, install vent termination. The stainless steel cap termination manufactured by the vent manufacturer is recommended. However, when the vent terminates several feet above ground level and there are no trees, plants, etc. within several feet, a 45° elbow can be used as termination. The elbow must be turned down to prevent rain from entering.

NOTE:

- Some horizontal through wall installations may require a "T" and 3 to 5 feet (91 to 152 cm) of vertical pipe outside the building to help naturally draft in the unit.
- This may be required if a proper burn cannot be maintained, after the stove has been tested and the airflow set.
- This is due to the back pressure in the exhaust caused by airflow around the structure.
- All sections of pipe must have three (3) screws evenly spaced and all horizontal and vertical vent sections located within the house must have a bead of high temperature silicone installed on the male end of the pipe before installation to create a gas tight seal.

THROUGH WALL WITH VERTICAL RISE AND HORIZONTAL TERMINATION INSTALLATION - FREESTANDING:

A 45° elbow with a rodent screen may be used in place of the termination cap (or stainless steel termination hood).

Figure 17 is the recommended installation set up.

Figure 18 is the installation to use if there is a concrete or retaining wall in line with exhaust vent on a pellet stove. The termination must be 12" (30 cm) from the outside wall and 12" (30 cm) above the ground.

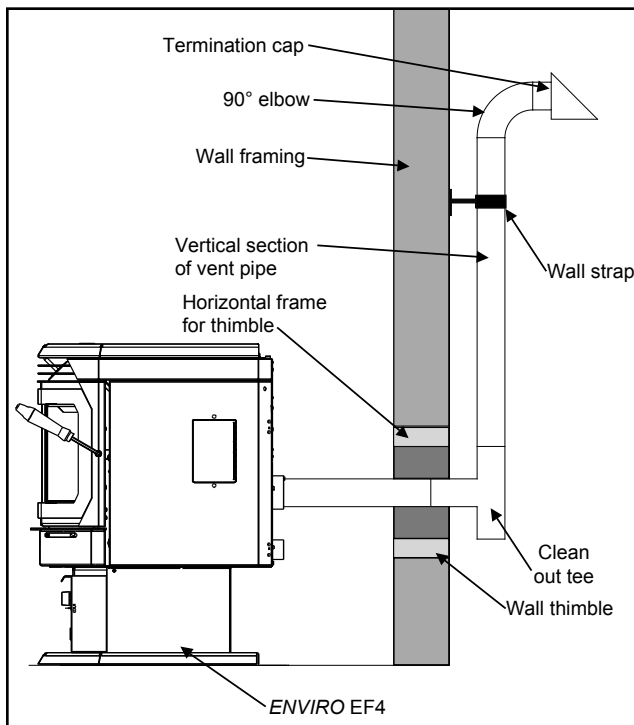

Figure 17: Venting horizontally with rise.

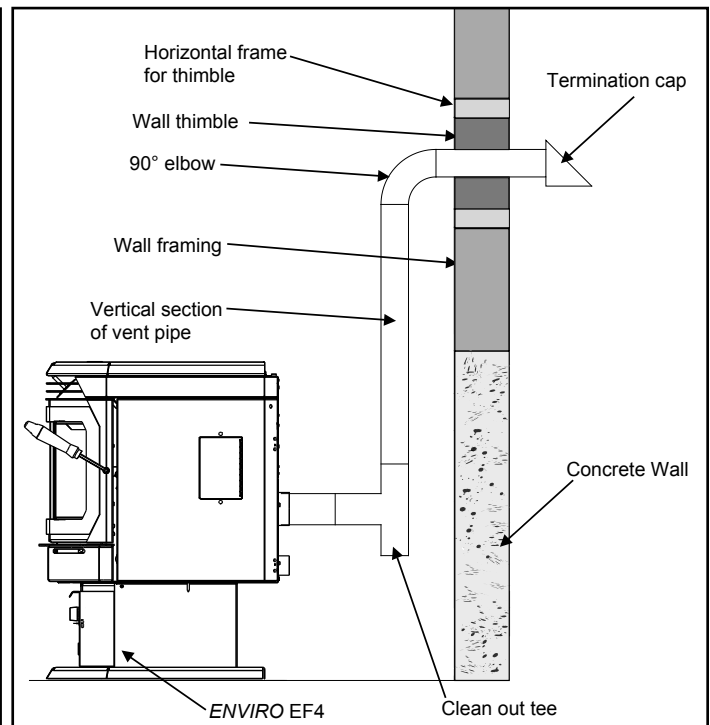

Figure 18: Venting with concrete wall behind unit .

INSTALLATION

INSIDE VERTICAL INSTALLATIONS - FREESTANDING:

1. Choose a stove location that is ideal. See the section "DECIDING WHERE TO LOCATE YOUR PELLET APPLIANCE."
2. Place a non-combustible hearth pad where necessary.
3. Place the unit on the hearth pad (if installed on a carpeted surface) and space the unit in a manner so when the pellet vent is installed vertically, it will be 3" (7.6 cm) away from a combustible wall.
4. Locate the center of the fresh air intake pipe on the unit. Match that center with the same point on the wall and cut a hole about 1 5/8" (41 mm) in diameter.
5. Install the fresh air intake pipe.
6. Install the tee with clean out.
7. Install the pellet vent upward from there. When you reach the ceiling, make sure that the vent goes through the ceiling fire stop. Maintain a 3" (7.6 cm) distance to combustibles and keep attic insulation away from the vent pipe. Maintain an effective vapor barrier.
8. Finally, extend the pellet vent to go through the roof flashing.
9. Ensure that the rain cap is approximately 36" (915 mm) above the roof.

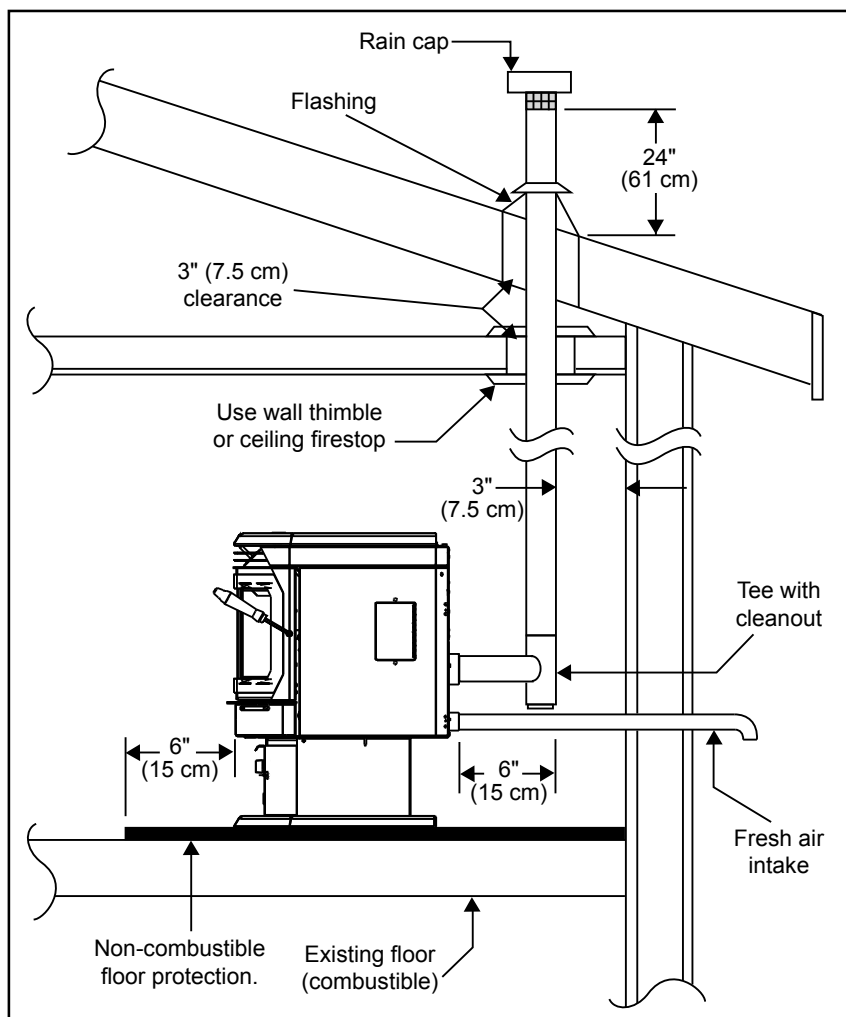

Figure 19: Inside Vertical Installation.

OUTSIDE VERTICAL INSTALLATIONS - FREESTANDING:

To accomplish a outside vertical pipe installation, follow steps 1 through 5 in the "INSIDE VERTICAL INSTALLATIONS - FREESTANDING" section and then finish it by performing the following (refer to Figure 20).

1. Install a tee with clean out on the outside of the house.
2. Install PL vent upward from the tee. Make sure that you install support brackets to keep the vent straight and secure.
3. Install ceiling thimble and secure the flashing as you go through the roof.
4. Ensure that the rain cap is approximately 36" (91.5 cm) above the roof.

INSTALLATION

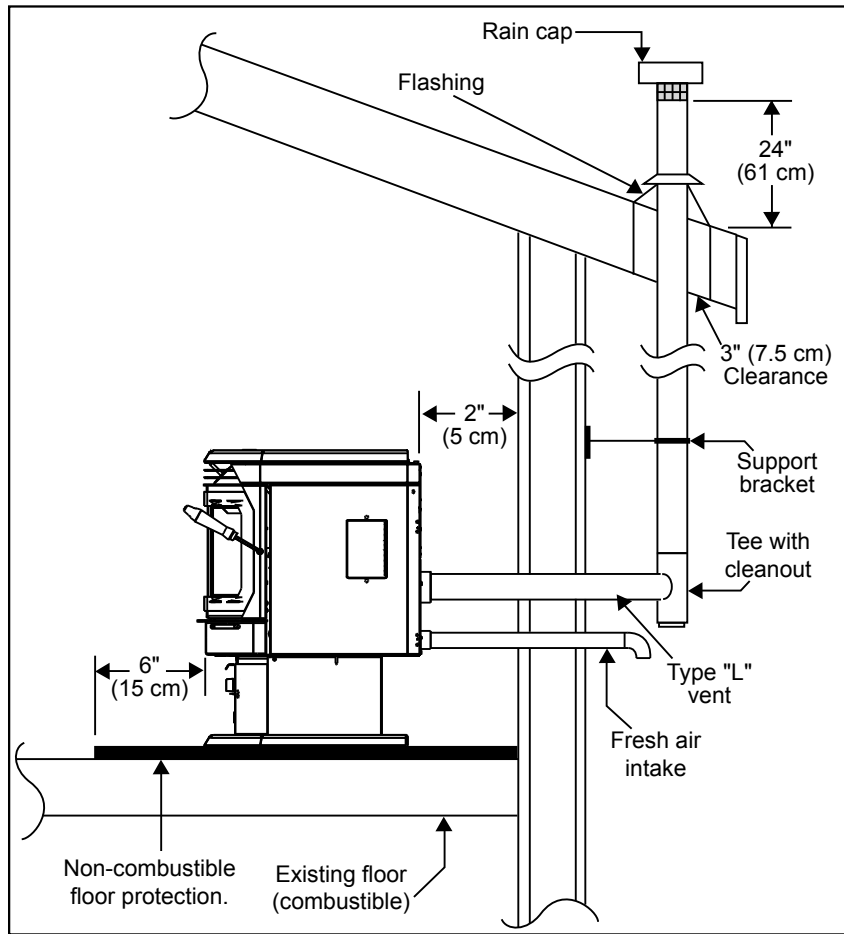

Figure 20: Outside Vertical Installation.

HEARTH MOUNT INSTALLATION - FREESTANDING:

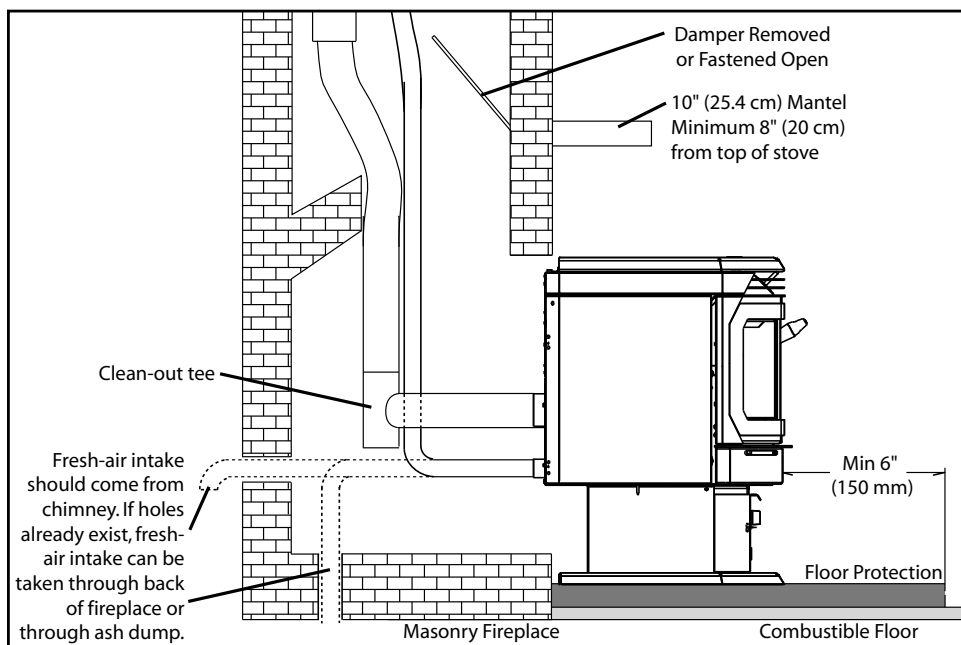

Figure 21: Freestanding hearth mount installation.

Refer to Figures 21 and 22.

1. Install the hearth pad.
2. Lock fireplace damper in the open position.
3. Install a positive flue connector at the fireplace dampers.
4. Connect a tee or a 90° elbow to the exhaust pipe.
5. Install flexible stainless steel liner or listed pellet vent to the top of the chimney.

INSTALLATION

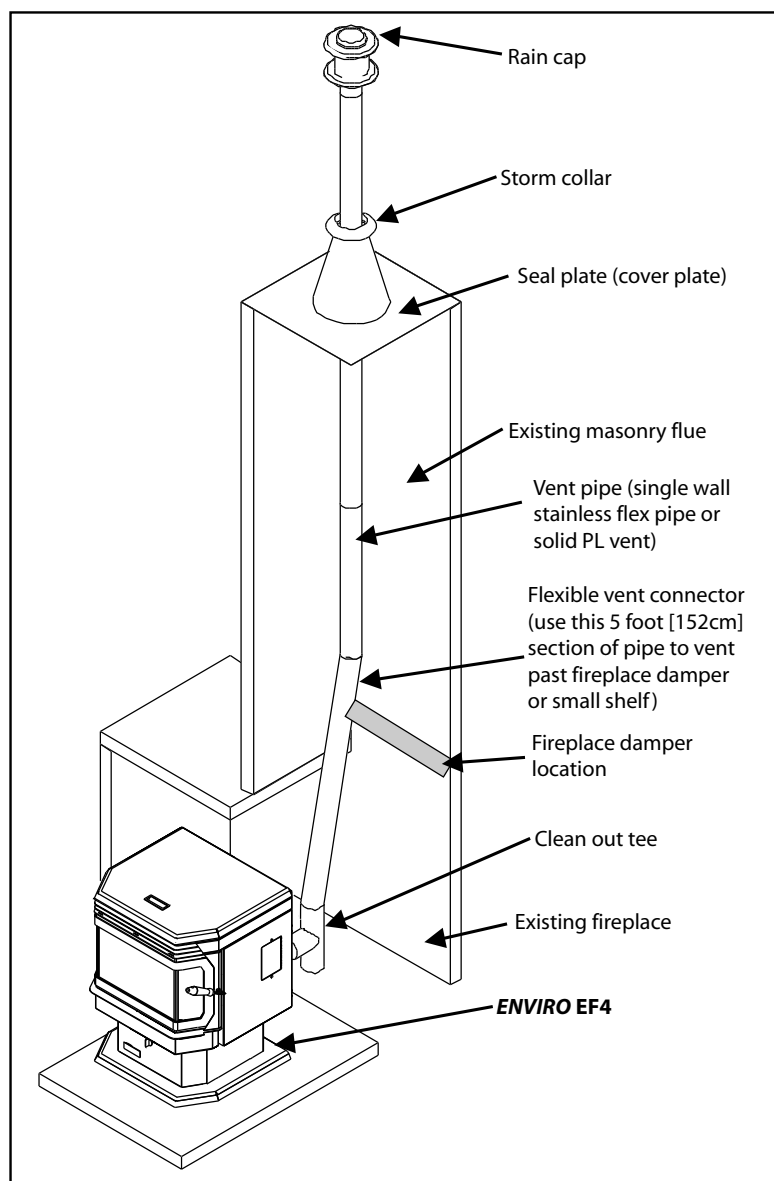

Figure 22: Freestanding hearth mount installation overview.

MASONRY FIREPLACE INSTALLATION - FIREPLACE INSERT:

The fireplace insert model requires a surround panel and a pedestal. When installing this unit, ensure that the pedestal is removed from the inside of the hopper and installed on the bottom of the unit (see "PEDESTAL INSTALLATION - FIREPLACE INSERT").

Assemble surround panel (see "ASSEMBLING THE SURROUND PANEL - FIREPLACE INSERT") before starting installation.

A non-combustible hearth pad must cover combustible flooring underneath, as well as 6" (150 mm) in front of the heater and 6" (150 mm) to the side of the heater.

1. Install the hearth pad.
2. Lock the fireplace damper in the open position.
3. Install a positive flue connector at the fireplace damper.

INSTALLATION

4. Connect a tee or 90° degree elbow to the exhaust pipe.
5. This fireplace insert must be installed with a continuous chimney liner of 3" or 4" diameter extending from the fireplace insert to the top of the chimney. The liner must conform to type 3 requirements of CAN/ULC S635.
6. (Recommended) Install fresh air intake either through the back of the fireplace or through the positive flue connector.

When installing the insert into a masonry fireplace, **DO NOT** remove any bricks or masonry, with the following exception: masonry or steel, including the damper plate, may be removed from the smoke shelf and adjacent damper frame, if necessary, to accommodate a chimney liner. Do this only if their removal will not weaken the structure of the fireplace and chimney, and will not reduce protection for combustible materials to less than that required by the national building code.

When installing the fireplace insert into a zero clearance fireplace, **DO NOT** cut or modify any factory firebox parts. If the fireplace insert does not fit into a zero clearance fireplace, we recommend you use an ENVIRO freestanding model and install as a hearth mounted unit. Install a 3" (76 mm) flex pipe from the stove to the top of the chimney (see "HEARTH MOUNT INSTALLATION - FREESTANDING:").

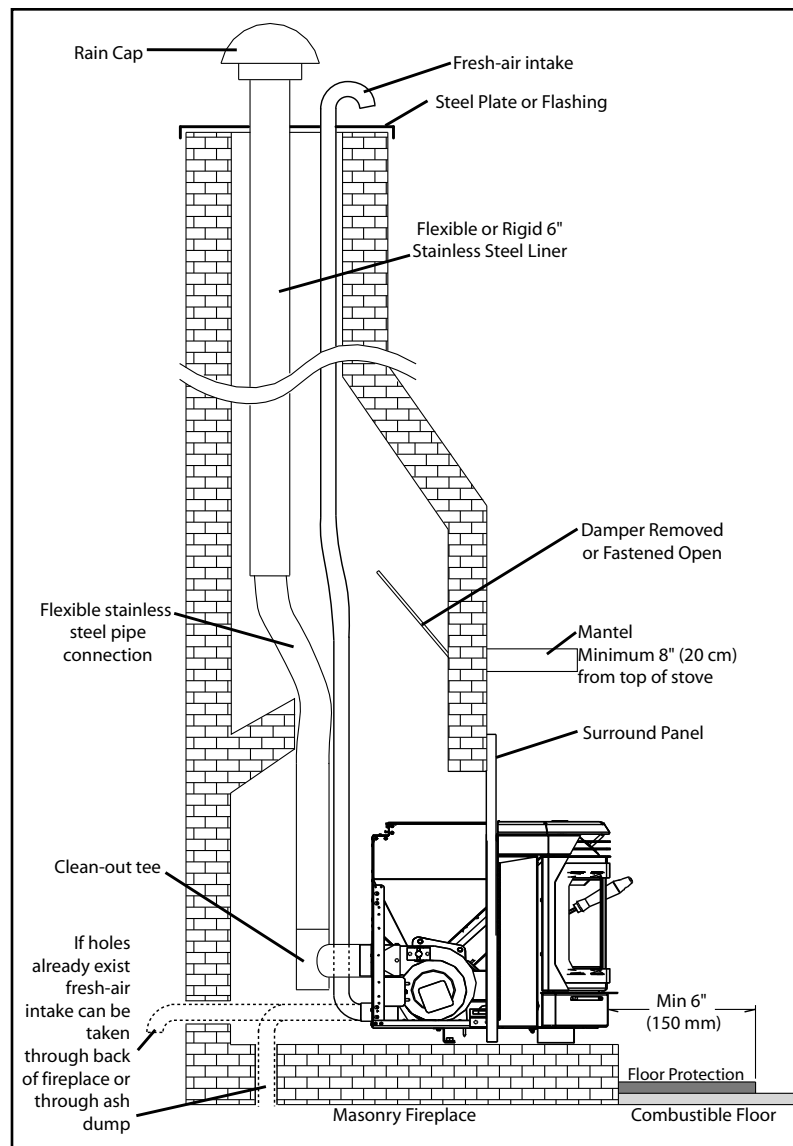

Figure 23: Masonry fireplace installation.

INSTALLATION

SLIDER/DAMPER SETTING:

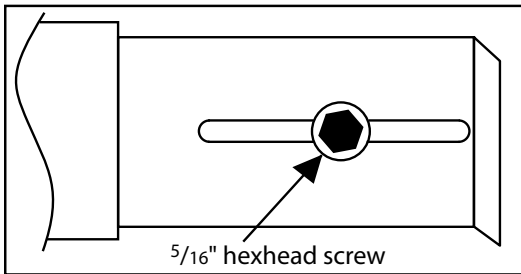

Figure 24: Slider Damper.

This is used to regulate the airflow through the pellet stove.

The slider damper is pre-set from the factory; it is set and held in place with a $\frac{5}{16}$ " hex screw. This setting does not mean it should not be re-adjusted for fuel quality.

The slider damper is located behind the left side panel. To open the left side panel, undo the one screw located in the upper front corner of the cabinet side

SPECIAL NOTES:

Pellet quality is a major factor in how the pellet stove will operate. If the pellets have a high moisture content or ash content the fire will be less efficient and has a higher possibility of the fire building up and creating clinkers (hard ash build-up).

If the fire should happen to go out and the Dial-A-Fire has been set on the lowest setting, the Slider Damper should be pushed in slightly, decreasing the air in the firebox or the Dial-A-Fire and Auger Trim can be turned up slightly.

If, after long periods of burning, the fire builds up and overflows the burn pot or there is a build up of clinkers, this would be a sign that the pellet quality is poor, this requires more primary air, the slider damper must be pulled out to compensate. Pulling the slider damper out gives the fire more air.

The easiest way to make sure that an efficient flame is achieved is to understand the characteristics of the fire.

- A tall, lazy flame with dark orange tips, requires more air – Open slider (pull out) slightly.
- A short, brisk flame, like a blowtorch, has too much air – Close slider (push in) slightly.
- If the flame is in the middle of these two characteristics with a bright yellow/orange, active flame with no black tips then the air is set for proper operation.

Taking a reading of vacuum pressure inside the firebox with a magnehelic gauge can be used to set the slider for best combustion. **The best settings are a reading of 0.11 to 0.12 inches of water column on the high fire setting. Some fuels may require higher or lower settings.**

INSTALLATION OF CONTROL PANEL IN THE INSERT SURROUND PANELS:

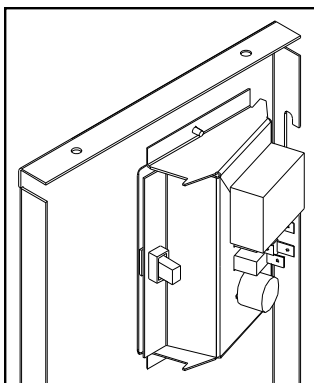

Figure 25: Control Panel Back.

When installing the control panel into the surround panel, the surround does not need to be assembled. The control board will be found in behind the firebox.

Place the control panel on the backside of the right surround panel so the hinge is on the outside and the top and bottom holes on the control panel line up with those on the surround. Attach using two (2) T-20 screws through the front of the surround into the circuit board control panel.

After the surround has been assembled and is ready to be installed on the unit, plug the wiring harness into the control panel (see Figure 25).

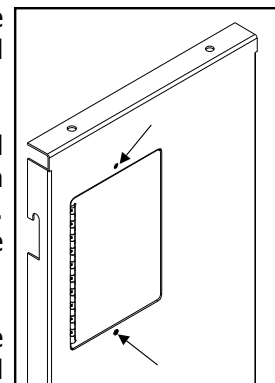

Figure 26: Control Panel Cover.

INSTALLATION

ASSEMBLING THE INSERT SURROUND PANELS:

1. To assemble the surround panels, lay the panels face down on a soft flat surface and align the outer edges of the sides with the top panel. Bolt the sides to the top using two (2) $\frac{1}{4}$ " nuts and bolts on each side (refer to Figure 27).
2. Assemble the trim using the corner hardware and screws supplied in the faceplate packaging. Install corner hardware into the side trim, then push into the top frame (refer to Figure 28).
3. Place the brass trim over the panel assembly.
4. Place the assembled surround panel around the stove; align the slots with the screw heads. Push back and then down to engage the surround slots on the mounting screws. Make sure the top surround panel sits flat on the stove.

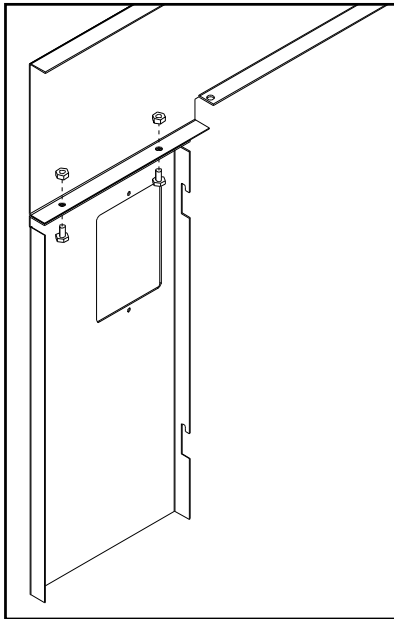

Figure 27: Assembling the Surround Panel, back view.

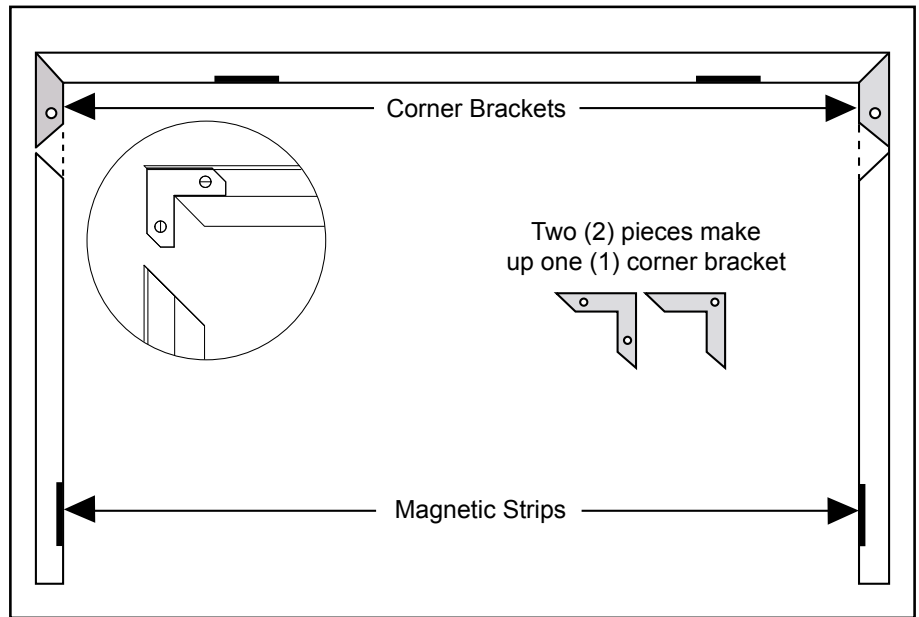

Figure 28: Assembling Trim for Surround Panel.

INSTALLATION AND REMOVAL OF INSERT SURROUND PANELS:

Plug the wiring harness into the control panel (see Figure 25). Place the assembled surround panel around the stove; align the slots with the screw heads. Push surround in then down to engage the surround slots on the mounting screws (see Figure 29). Make sure the top surround panel sits flat behind the stove top.

REMOVAL:

When maintenance is required on the unit the surround must be removed. Pull the surround straight up till it stops then pull it out about 4" (10 cm) and rest the surround on top of the unit while the control panel is removed or disconnected.

If electrical connection is required for maintenance, remove the control board control panel from the surround.

If electrical connection is not required for maintenance, remove the wiring harness from the bottom of the control board control.

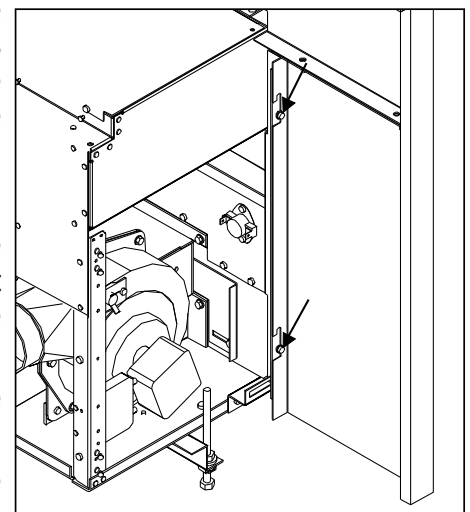

Figure 29: Panel placed on unit.

INSTALLATION

INSTALLATION OF DOOR A:

WARNING: DO NOT install the EF4 plated door A when unit is hot or is in operation.

REMOVE PAINTED DOOR A:

Remove the door assembly by opening the door, use the Allen key with the wood handle that was provided with the stove (see Figure 30). Lift the door up over the hinge pins and out. Lay the door down on a soft surface.

Remove the two end covers using a T-20 screwdriver, each side has two screws (see Figure 31). Place end covers and screws to the side.

There are four screws, one in each corner, that hold the painted door in place (see Figure 32), remove the screws with a T-20 screwdriver and place the screws to the side. Discard the painted door A.

INSTALL PLATED DOOR A:

Place the plated door (gold or nickel) in position and fasten with the four T-20 screws that were used on the painted door. Ensure the screws are tight.

Reinstall the two end covers with their two screws each. Tighten the screws.

Close the door assembly using the Allen key with the wood handle.

CLEANING THE PLATED DOOR A:

It is important to note that fingerprints and other marks can leave a permanent stain on plated finishes. To avoid this, give the face a quick wipe with denatured alcohol on a soft cloth BEFORE lighting the fireplace. Never clean the face when it is hot, let the stove completely cool off. Do not use other cleaners as they may leave a residue, which can become permanently etched into the surface.

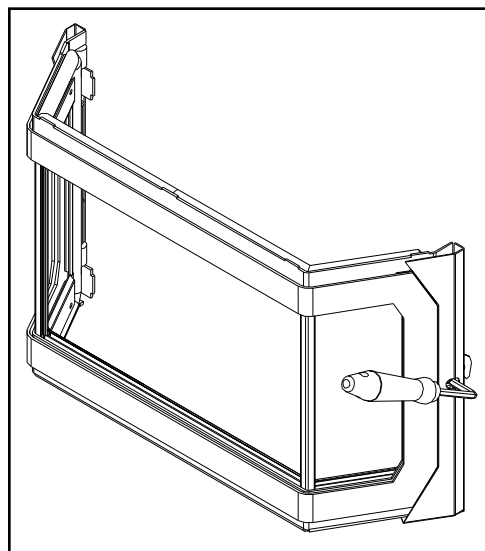

Figure 30: EF4 complete door.

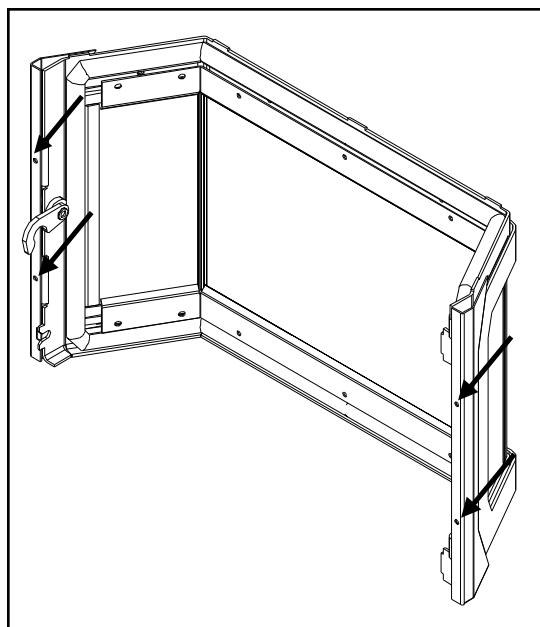

Figure 31: EF4 end screws.

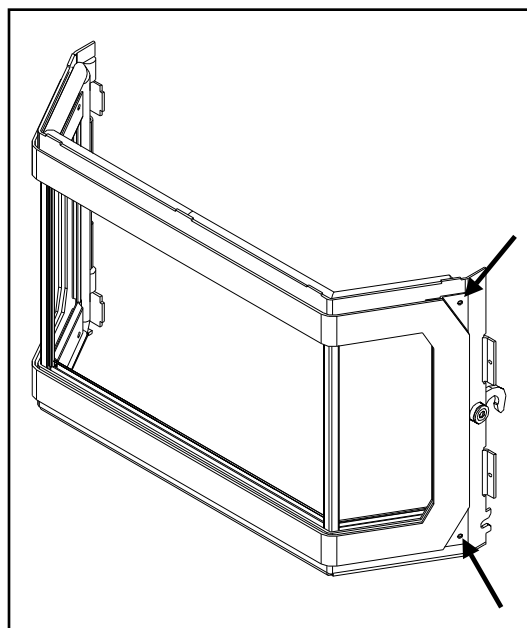

Figure 32: EF4 front screws.

TROUBLESHOOTING

DO NOT:

- Hold the start-up switch down; this is a momentary contact switch and can be damaged if held down too long.
- Service the stove with wet hands. The stove is an electrical appliance, which may pose a shock hazard if handled improperly. Only qualified technicians should deal with possible internal electrical failures.
- Remove any screws in the firebox without first lubricating them with penetrating oil.

What to do if:

1. The stove will not start.
2. The stove will not operate when hot.
3. The exhaust blower will not function normally.
4. The convection blower will not function normally.
5. Ignitor: The pellets will not light.
6. The auger motor does not function normally.
7. The dial-a-fire has no effect on the fire.
8. The stove will not shut off.
9. The stove keeps going out.

***NOTE:** All troubleshooting procedures should be carried out by qualified technicians or installers.

1. The stove will not start

- ✓ Make sure the stove is plugged in and the wall outlet is supplying power.
- ✓ Push the Start-up switch. If the stove fails to start, unplug the unit and open the hinged side panels (held tight with one screw at the top, front).
- ✓ With the stove unplugged, examine all connections. Make sure they are firmly connected and that there are no exposed wires touching the stove (except the chassis ground wire).
- ✓ Check the continuity and placement of connections against the "WIRING DIAGRAM" in this manual.
- ✓ Ensure that the connections to the fifteen (15) minute start-up timer are correct.
- ✓ Attempt to bypass the switch by inserting a jumper wire between the red and white wires that attach to the switch. Plug the stove back in. If the stove starts, replace the switch.
- ✓ If this fails, replace the (15) minute start-up timer.

Caution: Installation of a new start-up timer without checking the ignitor resistance may cause another failure to the new start-up timer due to a short in the ignitor. The proper resistance through the ignitor should be 138Ω to 250Ω.

2. The stove will not operate when hot

- ✓ Check the hopper for fuel.
- ✓ Incorrect air damper setting - Excessive air may consume the fire too quickly before the next drop of fuel, leaving completely unburned fuel in the burn pot liner. Insufficient air will cause build up, further restricting the air flow through the Burn Pot Liner. This in turn will cause the fuel to burn cold and very slowly. Fuel may build up and smother the fire. **(NOTE: Unit may require a change to the vent system or installation of fresh air to correct Air to Fuel ratio problems).**

TROUBLESHOOTING

- √ Combustion Blower failure - The Combustion Blower is not turning fast enough to generate the proper vacuum in the fire box. Visual Check – is the blower motor turning?
- √ Check Vacuum levels in the exhaust channel by bypassing the Vacuum Switch, then remove the Vacuum hose from Vacuum Switch. Check exhaust vacuum readings by placing the open end of the Vacuum Hose on a Magnahelic Gauge (readings must be above 0.10" W.C. on low fire).
Note: If the motor fails to reach a 0.10" W.C. reading, then replace the Combustion Blower.
- √ Poor Quality Fuel – Insufficient energy in the fuel to produce enough heat to keep the stove burning or operational.
- √ Exhaust Temperature Sensor failure – Bypass sensor located on Exhaust Blower. If stove now operates properly, the unit may require cleaning or a new sensor. Contact your local dealer for service.
- √ The unit may require cleaning. Contact your local dealer for service.
- √ Unplug the stove, open the left side panel. Jump the two (2) brown leads that are attached to the 120°F (49°C) temperature sensor. If the stove operates replace the 120°F (49°C) sensor.

3. The exhaust motor will not function normally

- √ Open the left side panel, check all connections against the "WIRING DIAGRAM" in this manual.
- √ Thoroughly check for broken wires or connections.
- √ If all the connections are verified and the exhaust blower does not function at all, tap lightly on the exhaust blower's motor end cap. This may loosen a tight motor.
- √ Apply 220 V AC directly to the exhaust blower. If the motor does not run, replace the blower.
- √ If the motor runs, check the exhaust potentiometer in the dial-a-fire. Remove the grey wires from the exhaust motor speed controller and measure the resistance (10Ω. to 400kΩ). If this range is not present or it is an open circuit, replace the speed controller.
- √ Check all wires for continuity.
- √ Replace the exhaust motor phase control (speed control module).
- √ Contact your local dealer for service.

4. The convection blower will not function normally

- √ Check all the connections between the controller, switch, and the convection blower against the "WIRING DIAGRAM" in this manual.
- √ If the convection motor will not run, apply 220 V AC to the motor directly. If the motor runs, replace the fan controller. If the motor does not run, the convection blower has failed. Replace the blower.
- √ If the convection blower runs on high at all times (no control with the fan controller), check the connections from the 160°F (71°C) sensor (located on the upper left side of the fire wall) and convection fan controller to the blower. Disconnect one of the wires from the sensor. If control of the convection blower returns to the fan controller, replace the sensor.
- √ If the motor is still on high, re-connect the sensor and replace the convection fan controller.

TROUBLESHOOTING

5. Ignitor- Everything else in the stove operates but the ignitor will not light the pellets

- ✓ Make sure the burn pot liner is up tight and square to the ignitor tube.
- ✓ Check to see if the exhaust blower is operating.
- ✓ Check all the electrical connections on the 120°F (49°C) temperature sensor located on the exhaust channel.
- ✓ Check the connections at the ignitor socket.
- ✓ Place a jumper wire between the two (2) leads on the 120°F (49°C) temperature sensor. If the ignitor works, **replace the sensor**.
- ✓ If the ignitor does not work, **replace the ignitor**

NOTE: The ignitor should be bright orange in color. If not, replace the ignitor.

6. The auger motor will not function normally

- ✓ Check for obstructions in the hopper system.
- ✓ Make sure the exhaust blower is operating.
- ✓ Make sure the dial-a-fire is turned on.
- ✓ Unplug the stove and open the side and back panels.
- ✓ Check all the connections to the auger motor, auger dial-a-fire, vacuum sensor, 200°F (93°C) temperature sensor and the timing control module against the "WIRING DIAGRAM" in this manual.
- ✓ Check the condition of the vacuum hose (located on the left side of the stove). It should not be cracked or torn and should be installed on the top air inlet tube on the vacuum sensor.
- ✓ Check the manual reset button on the 200°F (93°C) temperature sensor. If this sensor has been tripped, check for the cause of the over-heating before pushing the red button in. Check auger for movement.
- ✓ If the auger still does not work, then apply 220 V AC directly to the auger motor. If the auger motor does not work, replace it.
- ✓ By pass the 200°F (93°C) temperature sensor with a jumper wire. Check the auger. If the auger works replace the sensor.
- ✓ Check the vacuum sensor by placing a jumper wire between the blue wires that are attached to the sensor. If the auger works, test to see if the exhaust blower is producing enough firebox vacuum.
- ✓ To test the exhaust vacuum, place a magnehelic gauge in the sensor end of the vacuum tube. It should read 0.23" W.C. If the reading is good then replace the vacuum sensor.
- ✓ If the auger motor still does not work, then attempt to by-pass the auger dial-a-fire control by removing the leads from the timing control module's second delay pins and placing a jumper across the pins. If the auger now cycles very quickly, test the dial-a-fire potentiometer. If the auger did not cycle, then replace the timing control module.
- ✓ To test the dial-a-fire potentiometer. The potentiometer should have a range of 150 K Ω to 900 K Ω (\pm 10%). If the range is not close, then replace the potentiometer.
- ✓ Check the voltage across the load pins of the timing module. It should be around 1 V to 2 V, cycling to line voltage during an auger pulse. If not, replace the timing control module.
- ✓ Call your local dealer for service.

TROUBLESHOOTING

7. The dial-a-fire has no effect on the fire

Make sure all connections to the timer control module are secure.

Perform a resistance test to the dial-a-fire potentiometer by placing the two (2) test leads from a multimeter into the leads of the potentiometer. The potentiometer should have a range of 150 K Ω to 900 K Ω (\pm 10%).

Potentiometer Readings:

Full counter-clockwise (switched off) = open circuit, overload or infinite resistance

Low fire 800 K Ω to 900 K Ω

High fire 150 K Ω to 185 K Ω

If the range is not close or does not vary then replace the potentiometer.

8. The stove will not shut down

✓ Check the connections to the 120°F (49°C) exhaust temperature sensor, start-up switch and the start-up timer against the "WIRING DIAGRAM" in this manual.

✓ Check the 120°F (49°C) temperature sensor by removing one (1) of the brown wires from the sensor. The unit should shut down right away as long as the start button was not pressed within fifteen (15) minutes of this test. If the stove shuts down within fifteen (15) minutes, replace the 120°F (49°C) sensor. If the stove does not shut down within fifteen (15) minutes, test the switch.

✓ To test the switch, the stove must be cold. Pull the plug, then plug the stove back in. If it fails to start, replace the switch.

9. The stove keeps going out

✓ If the stove goes out and leaves fresh unburned pellets or cigarette-like ashes in the burn pot liner, the fire is going out before the 120°F (49°C) temperature sensor shuts the stove off.

- Check to see that the slider is in the correct position.

- Turn the dial-a-fire up slightly (poor quality pellets will require slightly higher settings).

✓ If the stove goes out and there are partially burned pellets left in the burn pot liner, the stove shuts down due to a lack of air, exhaust temperature or power failure.

- Adjust the slider damper.

- Check to see if the stove needs a more complete cleaning.

- Turn the dial-a-fire up slightly (poor quality pellets will require slightly higher settings).

- Did the power go out?

- Contact your local Dealer for service.

✓ If the stove goes out and there are no pellets in the liner, the auger is stopping.

- See "The auger motor will not function normally" and "The exhaust blower will not function normally."

WIRING DIAGRAM

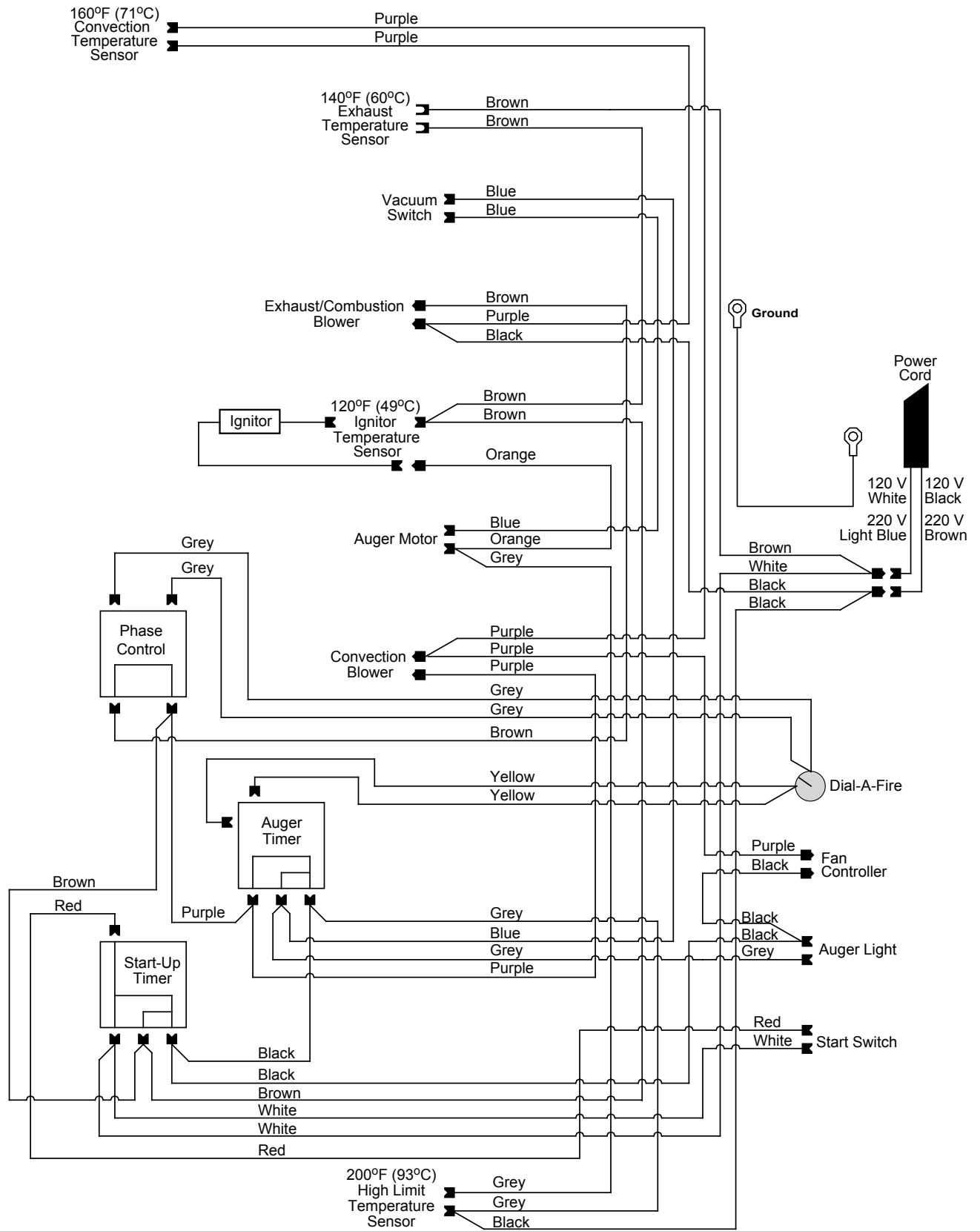

PART LIST

Reference Number	Description	Part Number
	Fan Controller Knob	EC-040
1	Auger motor - 220 V	EF-001-220V
	Convection blower insulator (gasket)	EF-006
	Combustion main impeller	EF-008
	Combustion cooling impeller	EF-009
2	140°F (60°C) exhaust temperature sensor ceramic	EF-010
	Combustion blower mounting gasket	EF-011
	Combustion blower housing gasket	EF-012
3	Fan temperature sensor 160°F (71°C)	EF-013
4	Ignition temperature sensor 120°F (49°C) ceramic	EF-015
5	High limit temperature sensor 200°F (93°C) manual reset	EF-016
6	Vacuum switch - 220 V	EF-017-220V
	Silicone hose	EF-018
	Aluminum hose barb	EF-019
7	Auger timer control - 220 V (3 sec)	EF-036-220V
8	Power up timer control - 220 V	EF-037-220V
9	Green light - 220 V	EF-041-220V
10	Start up switch	EF-043
11	Fan controller with knob - 220 V	EF-045-220V
	Ash pan latch (Insert)	EF-060
12	Auger brass bushings (set of 2)	EF-065
	Dial-a-fire knob	EF-067
	Shoulder bolt, hardened bushing and nut (set of 2)	EF-124
	Pellet stove cleaning brush	EF-156
13	Ash pan latch (Freestanding)	EF-178
	Pedestal & Ash Pan Gasket (10 feet)	EF-208
14	Convection blower - 220 V	EF4i-002-220V
	Convection blower impeller	EF4i-004
15	Ignition burn pot	EF4i-021
	Auger Brass Bushing and Plate	EF4i-026
16	Door Handle (wooden)	EF4i-028
17	Door latch with bolt (includes feral & bearing)	EF4i-029
18	Firebox liner with insulation	EF4i-047
	Heat exchanger rod	EF4i-051
	Door gasket ¾" firm round (7 feet)	EF4i-056
	Window channel tape	EF4i-058
19	Glass set	EF4i-062
	Slider damper spacers	EF4i-063

PART LIST

Reference Number	Description	Part Number
	Slider damper plate	EF4i-064
20	Firebox liner top plate	EF4i-066
	Wiring harness	EF4i-071
	Pedestal (Insert)	EF4i-074
21	Door latch cover & door hinge cover (set of 2)	EF4i-096
22	Back grill	EF4i-097
23	Ash sill	EF4i-103
24	Ash pan with latch	EF4i-105
25	Stove top (Freestanding)	EF4i-111
	Stove top (Insert)	EF4i-114
26	Front grill	EF4i-123
	Cabinet side set - left and right (Insert)	EF4i-131
	Hopper side - left	EF4i-135
	Hopper side - right	EF4i-135A
	Hopper lid spring mechanism (Insert)	EF4i-138
27	Pedestal (Freestanding)	EF4i-139
28	Cabinet side - left (Freestanding)	EF4i-142
29	Cabinet side - right (Freestanding)	EF4i-143
	CE power cord - 220 V	20-010-220V
30	Pin ignitor - 220V	20-016-220V
	Firebox ceramic wool insulation	20-017
31	Halogen cycle	20-034
32	Cleaning port covers	20-037
33	Control panel door	20-040
34	Dial-a-fire - 220 V	20-043
35	Steel burn pot liner (High Ash)	50-259
36	Auger	50-319
37	Control panel touch latch	50-323
38	Phase controller - 220 V	50-353
39	Glass extrusions (set of 2)	50-483
40	Phase control panel with door, decal, switch, and light - 220 V (Freestanding)	50-486
40	Phase control panel with door, decal, switch, and light - 220 V (Insert)	50-494
41	Flush handle (for hopper lid)	50-523
	EMI Filter - 220 V	50-648
	Owner's Manual - DIN	50-839
	Technical Manual - DIN	50-840
42	Exhaust Blower Assembly - 220 V	50-900
	5/8" ID Auger Collar with Screw	50-968

PART LIST - OPTIONS

Reference Number	Description	Part Number
	Log set	20-036
43	Steel brick lining	EF4i-130
	Bar set (set of 2) - Gold	EF4i-144
44	Door complete - Polished Nickel	50-261
44	Door complete - Gold	EF4i-092
44	Door complete - Painted	EF4i-094
45	Door cover (door A) - Painted	50-169
45	Door cover (door A) - Gold	50-170
45	Door cover (door A) - Polished Nickel	50-171
	Regular surround panel with Black trim (Insert)	50-102
	Oversize surround panel with Black trim (Insert)	50-103
	Oversize surround panel trim only - Black (Insert)	50-119
	Regular surround panel trim only - Black (Insert)	50-120
	Oversize surround panel trim only - Nickel (Insert)	50-131
	Regular surround panel trim only - Nickel (Insert)	50-132
	Regular surround panel trim only - Brass (Insert)	EC-051
	Oversize surround panel trim only - Brass (Insert)	EC-052
	Tapped corner bracket (Insert)	EC-053
	Regular surround panel (Insert)	EF4i-076
	Oversize surround panel (Insert)	EF4i-078
	Square oversize surround panel with brass trim (Insert)	EF4i-108

PART DIAGRAM - COMPONENTS



EF 4 Europe
COMPONENTS
August 2004

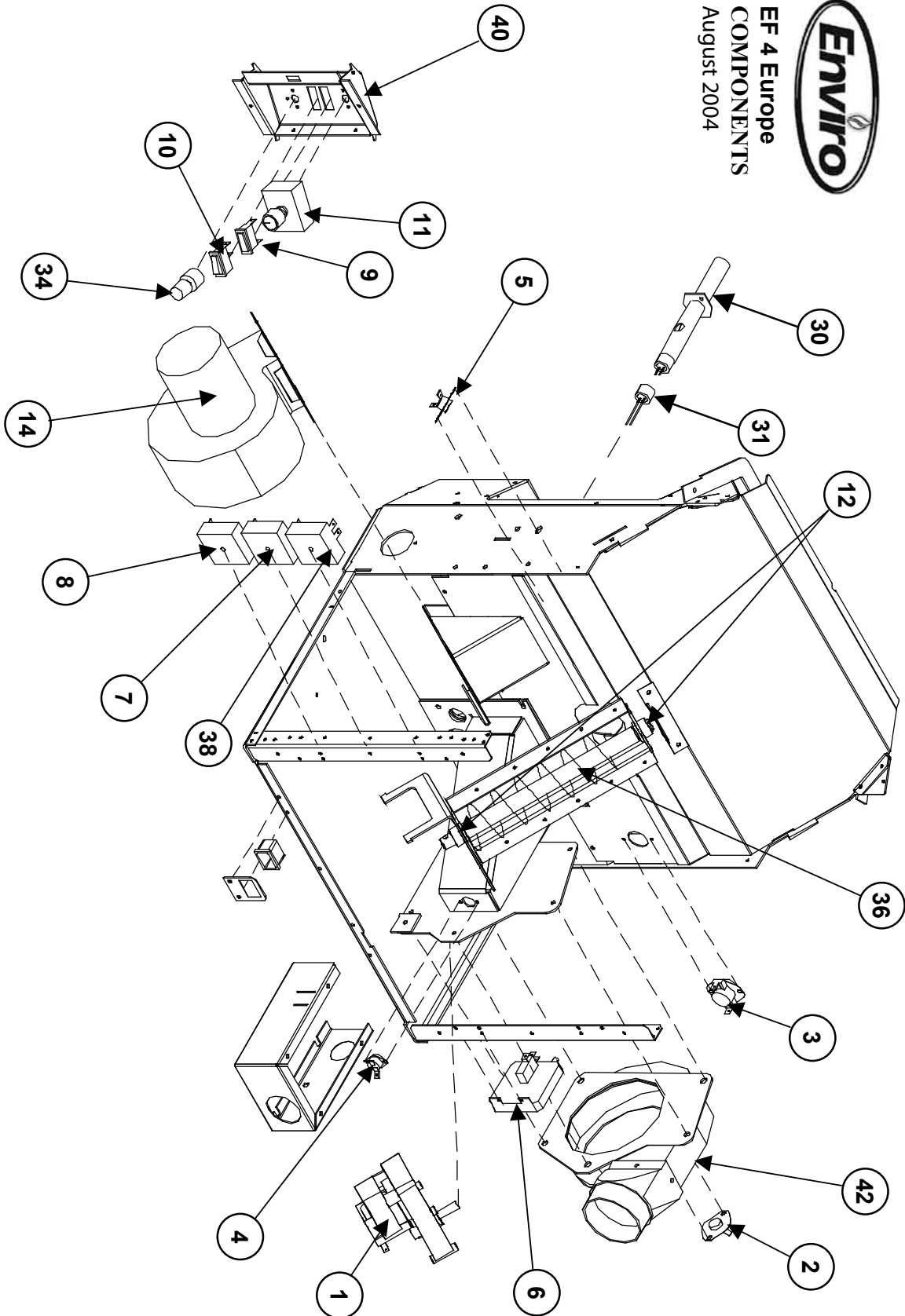

PART DIAGRAM - STEEL

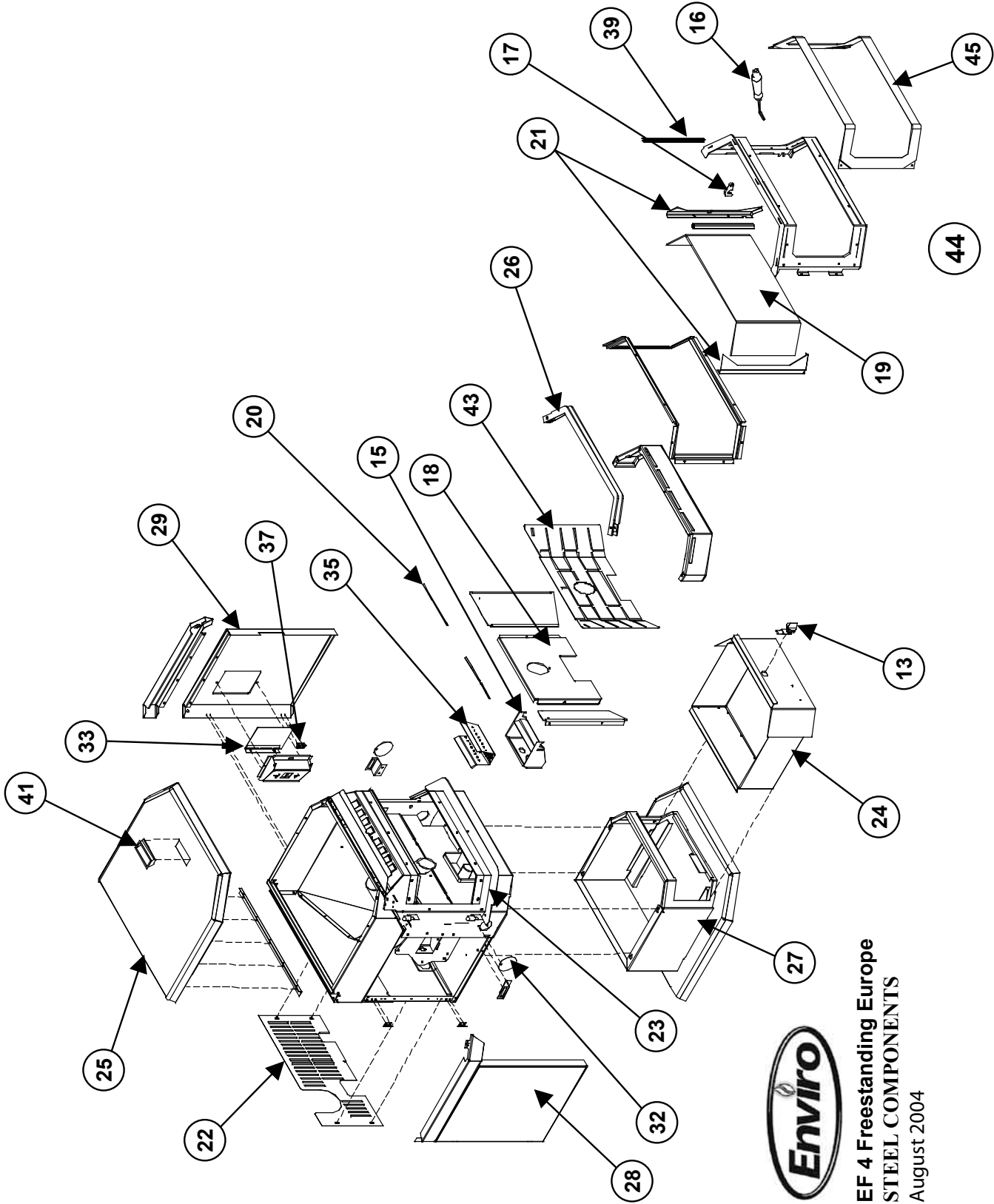

EF 4 Freestanding Europe
 STEEL COMPONENTS
 August 2004

WARRANTY

Sherwood Industries Ltd. gives a five year limited warranty on all steel manufactured parts. A one-year warranty is provided on all electrical components. The above limited warranties are extended only to the original purchaser.

There is no warranty on the following parts:

- Fiberglass rope baskets
- refractory material
- burn pot liner
- paint
- enamel finish or plating where it applies
- vacuum hose.

****NOTE:** The paint on the brick firebox lining may peel. This is due to the extreme conditions applied to the paint and is in no way covered under warranty.

WHEN FILING A WARRANTY CLAIM PLEASE COMPLETE THE FOLLOWING INFORMATION ON AN OFFICIAL WARRANTY CLAIM FORM:

TO THE DEALER:

- Name, Address and Telephone Number of purchaser and date of purchase.
- Date of Installation. Name of the installer and dealer. Serial Number of the appliance. Nature of the complaint, defects or malfunction, description and part # of any parts replaced.

TO THE DISTRIBUTOR:

- Sign and verify that work and information are correct.

ENSURE THAT YOU SPECIFY THE NATURE OF THE COMPLAINT, DEFECT, PERIODICAL MALFUNCTION, ETC.

The limited warranty covers defects in materials and workmanship as long as the products has been installed according to the manual's instruction. If the product is damaged or broken as a result of mishandling or misuse, the warranty does not apply. Removal and re-installation costs are not covered under this warranty.

It is the manufacturer's option whether to repair or replace the appliance. The shipping cost to and from the factory is paid by the consumer. All warranties by the manufacturer are set forth herein and no claim shall be made against the manufacturer on any oral warranty or representation.

Sherwood Industries Ltd. assumes no responsibility for damage caused by household power fluctuations or power surges.

Under Warranty

For the do-it-yourself Individual

The consumer should be aware that the pellet appliance needs setting using tools that he/she might not have. Consult an ENVIRO dealer. It is recommended than only an authorized ENVIRO dealer installs an ENVIRO unit. There will be no warranty coverage on parts destroyed or burnt out as a result of a consumer installation error or defect.

Sherwood Industries Ltd. reserves the right to make changes without any notice.

INSTALLATION DATA SHEET

The following information must be recorded by the installer for warranty purposes and future reference.

NAME OF OWNER:

ADDRESS:

PHONE: _____

NAME OF DEALER:

ADDRESS:

PHONE: _____

MODEL: _____
SERIAL NUMBER: _____
DATE OF PURCHASE: _____ (dd/mm/yyyy)
DATE OF INSTALLATION: _____ (dd/mm/yyyy)
MAGNEHELIC AT INSTALL: _____
INSTALLER'S SIGNATURE:

NAME OF INSTALLER:

ADDRESS:

PHONE: _____

MANUFACTURED BY:
SHERWOOD INDUSTRIES LTD.
6782 OLDFIELD RD. SAANICHTON, BC, CANADA V8M 2A3
www.envirofire.biz
September 10, 2004
C-10449