

INSTALLATION & OPERATION MANUAL

*Thank you for purchasing this product from a fine line of heating equipment.
We wish you many years of safe heating pleasure.*

Visit our web page at www.englishstoveworks.com for helpful information, frequently asked questions, parts & accessory orders and more.

NOTE: IF YOU HAVE A PROBLEM WITH THIS UNIT DO NOT RETURN IT TO THE DEALER. CONTACT CUSTOMER SERVICE @1-800-245-6489.

CAUTIONS AND WARNINGS:

This unit must be installed in accordance with these instructions and must comply with local building and fire codes. Failure to do so could result in a chimney or house fire, property damage, bodily injury or even death.

England's Stove Works highly recommends the use of smoke detectors and Carbon Monoxide detectors with any hearth product, including this unit. Follow all manufacturer's instructions when using smoke or Carbon Monoxide detectors.

Keep children, furniture, fixtures and all combustibles away from any heating appliance.

Maintain a minimum clearance of 30" (6" if using a Heat Shield) from the firebox and 18" from the flue pipe to any combustibles.

This product contains a catalytic combustor, which needs periodic inspection and replacement for proper operation. It is against the law to operate this wood heater in a manner inconsistent with the operating instructions in this manual, or if the catalytic element is deactivated or removed.

Our catalytic stoves are designed to burn seasoned, dry wood.

**NOTE: THIS STOVE IS *NOT* MOBILE HOME APPROVED
DO NOT PLACE IN A MOBILE HOME!**

24-ACD/FC , 50-SHW24/16 & 50-TRW24/16

COMPLIANCE STATUS

Type of Fuel	Wood
EPA Certificate Number	452
Emission Rate	2.7 Grams Per Hour
Overall Test Efficiency	82.88%
Heat Output Test Range	9,000 to 20,100 BTU/Hr.

Rev. 1/06



SAFETY NOTICE:

IF THIS STOVE IS NOT PROPERLY INSTALLED, A HOUSE FIRE MAY RESULT. FOR YOUR SAFETY, FOLLOW ALL OF THE INSTALLATION DIRECTIONS. CONTACT LOCAL BUILDING OR FIRE OFFICIALS ABOUT RESTRICTIONS AND INSTALLATION INSPECTIONS IN YOUR AREA.

This manual applies to six different model numbers: 24-ACD, 24-FC, 50-SHW24 and 50-SHW16, and 50-TRW24 and 50-TRW16. The 24-FC is an identical unit to the 24-ACD, except it does not have a blower system. The 50-SHW16 (50-TRW16) is identical to the 50-SHW24 (50-TRW24), except it does not have a blower system.

NOTE: FLUE SYSTEMS AND FLUE PIPE ARE NOT FURNISHED WITH THE UNITS. THEY MUST BE PURCHASED SEPARATELY.

SECTION 1: FLUE SYSTEM

A. Existing Flue System

If you have chosen a freestanding unit, this stove is designed to connect to an existing flue system, such as masonry or pre-manufactured Class A Flue systems. If you have a masonry flue system, you should inspect the inner liner very carefully for cracks in the liner; if there is no liner in your chimney, we recommend you install a stainless steel liner or have one installed. If you have an existing pre-manufactured flue system, you should inspect the inner liner to ensure there is no buckling or warping and no cracks in the liner.

Whether you have a masonry or pre-manufactured flue system, you should clean the chimney before installing your new unit to the flue system. We strongly recommend you have a qualified chimney sweep clean and inspect your flue system. The sweep can spot problems you may unknowingly overlook, and in most cases will be able to make any necessary repairs or at least recommend qualified people to do so.

It is not permissible to connect this unit to a chimney that is servicing another unit.

B. Flue Size Needed

The proper flue size is determined by the inside diameter of the flue collar of the unit. The stoves are equipped with a six-inch (6") top or rear exhaust collar; therefore, the connector pipe should be six inches (6") and never less in diameter than the flue collar on the stove. The area of the chimney liner must also be equal to or greater than the area of the flue collar on the stove. However, if the area of the flue is greater than the area of the flue collar, it should never be more than three times greater.

Example: The area of a six inch (6") diameter collar is 28.87 sq. inches; therefore the connector pipe should be a six inch (6") pipe and the chimney liner must be at least 28.87 sq. inches, but no greater than 84.8 sq. inches.

Note on Outside Air Hookup: You can use an outside air hookup with our catalytic stoves. We highly recommend it for homes built since the more air-tight construction standards went into effect. This involves connecting a metal pipe (usually three inches (3") in diameter - check your stove - and the pipe can be flex or rigid) from the air inlet pipe located on the bottom rear of the stove through your floor or wall. The outside end of this pipe should be covered in some manner (i.e. with a screen) to keep it clear of foreign matter.

Installation of 24-ACD/FC & 50-SHW24/16 (50-TRW24/16) Using a Masonry Chimney

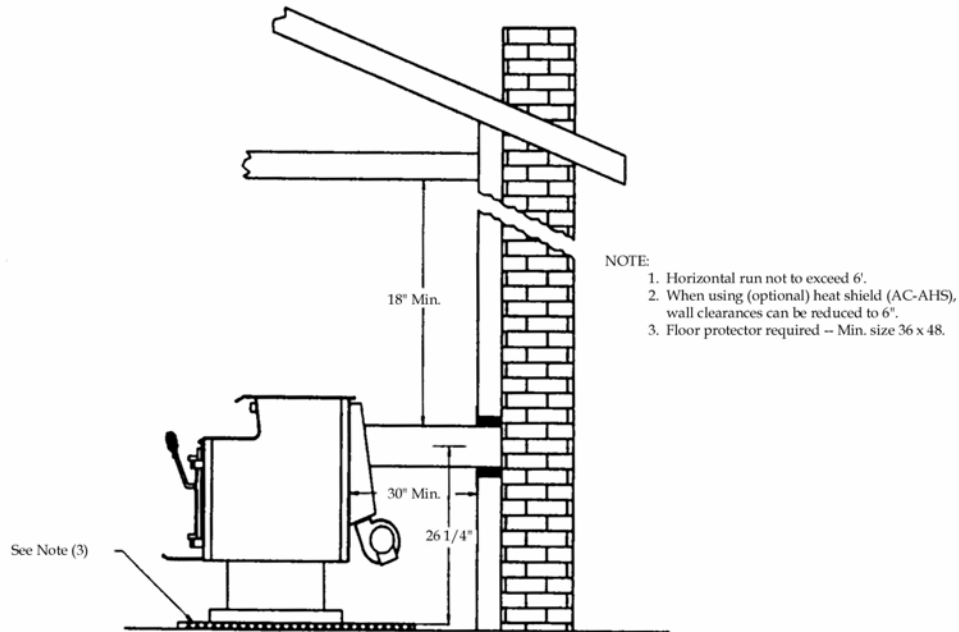

Installation of 24-ACD/FC & 50-SHW24/16 (50-TRW24/16) Using UL Approved Pre-Manufactured Chimney

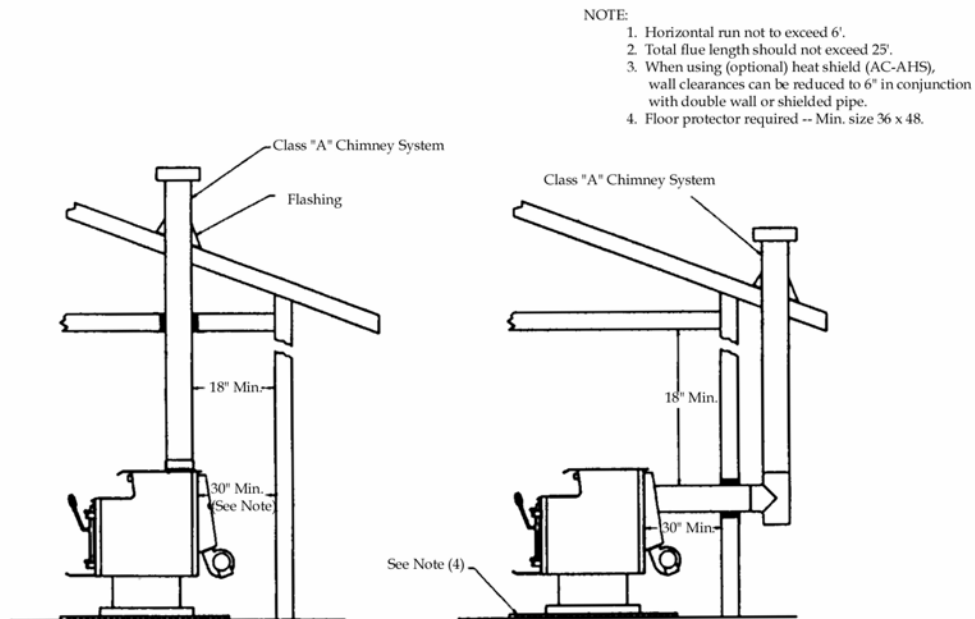

***IMPROPER INSTALLATION:** The manufacturer will not be held responsible for damage caused by the malfunction of a stove due to improper venting or installation. Call (800-245-6489) and/or consult a professional installer if you have any questions.

C. Top or Rear Exhaust

This stove comes with an adaptable top or rear exhaust flue system. When you open the box you will notice the unit is shipped for a top exhaust application; however, if you need a rear exhaust application, unbolt the CA-22 cap from the rear of the unit. Then, bolt it in place covering the hole on top of the unit, and bolt the CA-20 six inch (6") flue collar onto the rear of the unit using a 3/16" Allen head wrench, making sure all bolts are tight and the gasket is in place. Connector pipe should be 24-gauge steel and eighteen inches (18") from the wall or ceiling, unless you are using double wall or shielded pipe. This will reduce the clearance to combustibles to six inches (6").

D. Installation of a New Flue System

1. Masonry Flue: In the event that you plan to install a flue system by yourself or have a flue system installed, there are several avenues you can take. A masonry flue system is a popular and satisfactory system. If you are considering a masonry system, you should consult with your local building officials for the proper procedures in construction of a masonry chimney. We recommend you consult with and have your flue built by a licensed, bonded contractor.

Most masonry flues are placed against the outside wall and extend upward beside the house. The flue thimble is then inserted through the wall, making connection with the vertical flue and the stove flue pipe. Exercise extreme caution when drilling through the wall; you must maintain proper clearance between the connecting liner and any combustibles in the wall.

We also recommend that you have a flue door located at least two feet (2') below your flue thimble connection for easy access and clean-out. You should make this door as airtight as possible. It is the customer's responsibility to ensure the chimney or flue system is safe and in good operating condition. **The manufacturer will not be responsible for an accident attributed to a unit connected to a faulty chimney or flue system.**

2. Pre-Manufactured Flue System: Pre-Manufactured flue systems have become very popular, because this type system is fairly easy to install and when done correctly, it is very safe. There are many pre-manufactured flue systems on the market from which to choose. In making your choice be sure the system has a recognized label of approval such as U L, B.O.C.A. or I.C.B.O. -- any of these approvals will ensure the flue system is constructed of the proper materials and meets required safety standards.

There are two popular methods for installation of a pre-manufactured flue system. The first method, the most popular and least expensive, is through the ceiling and out the roof. This is the most direct route and creates a tremendous amount of draw due to having less pipe in the system, and is less expensive because insulated pipe is only needed from the ceiling and above. Single wall 24 gauge or thicker pipe is used from the unit to the ceiling.

The second method for installation of a pre-manufactured system is to go through the wall and up the side of your home or structure. This method is more expensive because more insulated pipe is required -- you must use insulated pipe through the wall and up the outside of your home. Whether you choose to go through the ceiling or through the wall, you must exercise extreme caution and maintain proper clearances to combustibles in either installation. Your flue pipe manufacturer furnishes a wall thimble or ceiling support box, and when these are installed properly the correct safety clearances will be met. If you choose a pre-manufactured flue system and you are not qualified or capable

of installing the system, you can consult your local dealer. In most cases he can recommend a contractor or sweep that can handle the installation. It is the customer's responsibility to ensure the chimney (or flue system) is safe and in good operating condition. **The manufacturer will not be responsible for an accident attributed to a unit connected to a faulty chimney or flue system.**

SECTION 2: FLOOR AND WALL PROTECTION

A. Floor Protection

If your floor is constructed of a non-combustible material such as brick or concrete, there is no floor protection required or needed. If your floor is constructed of a combustible material such as hardwood, carpet or linoleum, you must place protection between the unit and the combustible material.

There are many stove floor and wallboards on the market. You must be very cautious in choosing the proper protection; always look for a UL listed product. After examining the area in which you plan to locate your unit and determining it requires a board, select the proper size board needed. The approved protector board should be large enough to provide a minimum of eight inches (8") behind the stove, with sixteen inches (16") in the front or the side where the door is located and eight inches (8") on either side of the stove. These units require a minimum of 36" x 48" floor protection.

B. Wall Protection

These stoves can be placed within thirty inches (30") of a combustible wall such as paneling, wallpaper or drywall, unless your local codes state otherwise. If you need to place your unit closer to a combustible wall, you will need UL listed wall protection. There are many manufacturers, and most boards will require a one inch (1") air space between the board and the wall, which reduces your clearance by two-thirds (2/3). You can then place your unit within twelve inches (12") of a combustible surface. In addition, the wallboard only needs to be six inches (6") higher than the top of the unit. After placing the unit twelve inches (12") from a combustible, the flue pipe will be closer than eighteen inches (18") to the combustible. This will require you to use double wall or shielded pipe that will allow the flue pipe to come within six inches (6") of a combustible. Always follow the pipe and board manufacturer's directions, and contact us if you have any questions.

C. Heat Shields

1. MODEL 24-FC, 50-SHW16 or 50-TRW16

The AC-FHS(B) side and rear heat shield attaches to the rear of the unit and wraps around the sides to allow for six inches (6") clearance to a combustible from the rear of the unit or from each corner if placed cater-cornered. You will still need the thirty inches (30") clearance in a parallel or corner installation, as the shield does not cover the complete side of the stove.

NOTE: You must use the top vent option of your unit when using this heat shield.

2. MODEL 24-ACD, 50-SHW24 or 50-TRW24

The AC-AHS/SH-HS22 side and rear heat shield is a two piece item which attaches to the rear of the stove and wraps around the sides to allow for six inches (6") clearance to a combustible from the rear of the unit, or from each corner if placed cater-cornered.

You will still need the thirty-inch (30") clearance on the sides, as the shield does not cover the entire side of the stove.

NOTE: You must use the top vent option of your unit when using this heat shield.

SECTION 3: FREESTANDING PLACEMENT AND INSTALLATION

A. Placement

Please take caution getting the stove into your home. All of these stoves are well constructed, which makes them rather heavy. To lighten the unit and make for easier handling, you can remove the door and the firebrick (after making a diagram of the firebrick placement) – we also recommend using a handcart. As a rule, three or four adults can handle any of these stoves. **Never try handling any of these products without help!** After the unit has been placed in position, replace the brick and door. Install the flue collar, then the spring handles on the door and the by-pass slide damper, and attach any optional equipment.

B. Chimney Connector Pipe

The black connector pipe must be six inches (6") in diameter (24 gauge steel pipe). **Do not** use aluminum or galvanized steel -- they cannot properly withstand the extreme temperatures of a wood fire. Do not use chimney connector pipe (single wall) as a chimney; you must connect your stove to a chimney comparable to those listed in this manual (See Section 1). A chimney connector must be attached to the stove and to each other with the crimped end toward the stove. This allows creosote to run into the stove and not onto the outside of the stove. As a safety precaution, all joints should be sealed with high temperature silicone (AC-RTV3) and secured with three sheet metal screws. For proper operation, the chimney connector should be as short as possible and horizontal lengths of chimney connector pipe should have an upward slope from the stove of ¼ inch per foot. Maintain eighteen inches (18") of clearance between the chimney connector and the wall and ceiling unless a wall protection system is installed. You can also use double wall or shielded pipe.

SECTION 4: ACCESSORY ITEMS

There are several accessory items available for your stove. It is suggested that you install any accessory items before proceeding to the next section; however, the accessories are designed to be Add-On items at any time. If you purchase accessories after you have bought your unit, simply let the stove cool down and add them as follows.

AC-102(BN)/SH-102 Brass (or Nickel) Lip & Ash Apron Trim

There are three (3) pieces of J-Channel trim in this kit, which snap onto the edges of the stove (the top front edges and the ash apron front edge). To remove the protective cover, start at one end and peel off the film. The pieces are precut to fit the edges – simply match the piece with the proper edge. Center the J-Channel on the edge, and with the short side of the channel down, force the underside of the channel over the edge of the metal. If the J-Channel is too tight for starting by hand you can tap it into place with a wooden block or rubber hammer. If the J-Channel is too loose and will not stay in place lay the long side down on a flat surface and bend (crimp) the short side slightly on each end and in the center. Follow this procedure with each piece.

You may order parts and options on our web site: www.englishstoveworks.com,
or by calling (800) 516-3636

**AC-106-P(BN) / SH106-P Brass (or Nickel) Window Trim
(Model 24-ACD/FC, 50-SHW24/16 or 50-TRW24/16)**

With the door closed, take the spring clip (which has a tee on one end) and twist it into the groove on the backside of the trim allowing the plain end of the spring to fall onto the groove. You can place the spring clip on any side of the trim; however, this side pointed down will hold best. Hold the spring clip in place and slide the bottom edge of the trim onto the bottom ledge of the window opening. With both hands press down and in, pushing the trim into place, then press all four (4) corners firmly to ensure they are in the window opening as far as they will go. This trim kit will adapt to the glass or the solid plaque. You may want to use furnace cement on the backside of the trim kit to better hold it in place.

AC-FHS(B) Side and Rear Heat Shield (Model 24-FC, 50-SHW16 or 50-TRW16)

This accessory item comes complete with the hardware necessary to install it to the rear of the stove. The side panels of the heat shield are broken on a 90-degree angle, making it necessary to spring the heat shield around the rear firebox wall. Next, move the heat shield forward over the two weld nuts on the rear of each side of the stove. While holding the shield in place, align the two slotted pre-punched holes in the rear of the heat shield with the weld nuts and fasten with the bolts provided. See the prior note on heat shields or the plate on the side of the stove for clearances to combustibles.

NOTE: You must use the top vent option of your unit when using this heat shield.

**AC-AHS/SH-HS22 Side & Rear Heat Shield
(Model 24-ACD, 50-SHW24 or 50-TRW24)**

This accessory item comes with the hardware necessary to install it to the rear of the stove. This is a two-piece heat shield, but is installed one piece at a time. There are weld nuts on the rear of each side of the above listed models. While holding each side of the AC-AHS in place, align the slotted pre-punched holes in the heat shield with the weld nuts and fasten with the bolts provided. See prior note on heat shields or the plate on the side of the stove for clearances to combustibles.

NOTE: You must use the top vent option of your unit when using this heat shield.

SECTION 5: OPERATING INSTRUCTIONS

A. Building a Fire

Your stove is equipped with a catalytic combustor that requires the following procedure in burning the unit from a cold start. Inspect your unit to ensure the combustor is well seated in the housing and the flame impingement baffle plate is in place before starting this procedure.

CAUTION:

Never light or restart a fire with kerosene, gasoline, diesel fuel or charcoal lighter fluid. Always open the by-pass damper before opening the stove door.

Notice: Your new unit and the connector pipe may smoke for a few minutes. This is called “cooking out” and is no cause for alarm, but it is a good idea to open all doors and windows during the first two (2) hours of operating a new stove. “Cooking out” is a one-time occurrence.

1. Place several wads of crushed paper evenly over the entire bottom of the firebox.
2. Lay small dry sticks of kindling on top of the paper.
3. Pull out the draft handle below the ash lip and open the by-pass damper located on the right side of the unit (by pulling it out completely).
4. Be sure there are no matches or other combustibles in the immediate area of the stove. Always be sure the room is adequately ventilated and the flue is unobstructed.
5. Ignite the paper and leave the door cracked about one-half inch (1/2"). Allow the paper and kindling to burn freely for 15 to 20 minutes.
6. Once the kindling is burning freely, open the door slowly and add several pieces of split dry wood. Close the door again leaving a one-half inch (1/2") crack. Allow the stove to burn in this manner for another 15 to 20 minutes.
7. Once the split wood has started to turn to charcoal, slowly open the door and fill the firebox with seasoned wood. Close the door again, leaving a one-half inch (1/2") crack, and allow the stove to burn for another 15 to 20 minutes.
8. Close the door completely, leaving the draft control in the open position, and allow the unit to burn in this mode for 5 to 10 minutes. **NOTE:** If you have glass in the door you will notice the flame die or go away. This does not mean the fire has gone out; it is only burning more efficiently. Your stove is designed to burn wood slowly, and slow burning wood does not generate much flame.
9. Close the by-pass damper on the side of the unit, and watch underneath the rear of the unit for smoke. If you see smoke in this area, the catalytic combustor has not ignited properly; open the by-pass damper and allow the stove to burn another 10 minutes. This should give the combustor ample time to reach the operating temperature.
10. Once you are sure the combustor is working properly, close the draft control for about 5 minutes, then re-open the control or controls slightly (see "Draft Control").

NOTE: It is very important that you follow the above procedure to ensure the catalytic combustor ignites. The combustor will ignite at 400 to 500 degrees Fahrenheit. The manufacturer recommends the combustor be operated at 1000 to 1200 degrees Fahrenheit or 540 to 650 degrees Centigrade. Operating at a high temperature above 1800 degrees Fahrenheit or 1000 degrees Centigrade could damage the combustor. There is a 1/4" diameter hole located on the left side near the rear of the unit which is covered with a 1/4" plug; the plug can be removed and a catalytic probe thermometer (Part #AC-13) inserted through this hole, which will monitor the operating temperature of the combustor. We recommend the use of the Condor probe thermometer that can be purchased from your local dealer or ordered from our factory at (800) 245-6489.

B. Draft Control

These units have a draft control under the ash lip, which is used to control the amount of combustion air entering the firebox; this controls the heat output and the burn rate of the stove. The more you pull out (open) this draft control, the more combustion air enters the firebox and allows the stove to generate more heat. The desired setting for a long burn is to push the handle in completely, which closes the draft completely, then pull the control out one half to one inch (1/2" to 1"). No two flue systems operate the same, therefore, you will have to experiment with your unit to find the best setting for your stove and flue system.

C. Do Not Over-fire Your Unit

Burning flammable liquids, too much wood, or trash in the stove may result in over-firing. If the chimney connector pipe or stove glows red, the stove is over-fired. This condition may ignite creosote in the chimney, possibly causing a house or chimney fire. If this does occur, immediately shut down the unit by pushing in on the damper control below the ash lip, as well as the by-pass damper. Get out of the house and call the fire department. Since a chimney fire could cause structural damage to the chimney, do not use the stove until the chimney and chimney connector pipe have been inspected and any damaged parts have been repaired or replaced. A chimney sweep can perform the inspection of your flue system.

D. Everyday Fueling

This stove is designed to burn six to eight hours on one filling of good seasoned wood. At the end of a long burn cycle you will need to fill your unit again for another long burn cycle. See directions listed below:

1. **Always open the by-pass damper located on the right side of the stove.** Open both draft controls on the door or the pull damper under the ash lip depending on your model.
2. Crack the door about one inch (1") and leave it cracked for 2 to 5 minutes. This will allow the excess smoke in the unit to go up the flue and increase the draft.
3. Slowly open the door. You should have a hot bed of coals in the firebox or wood that has not completely burned. If the fire has gone out, stop here and refer back to the steps on building a fire.
4. Fill the firebox with dry seasoned wood and leave the door cracked about one-half inch (1/2"). Allow the fire to burn freely for about 15 to 20 minutes.
5. Close the door completely, leaving your draft control or controls in the open position and allow the stove to burn in this mode for 5 to 10 minutes.
6. Close the by-pass damper and watch the rear of the unit as previously described. If you see any smoke in this area the combustor has not reached the proper temperature; open your control or controls and allow the stove to burn another 5 minutes.
7. Once you are sure the combustor is operating properly, close the draft control and allow the stove to operate in this mode for about 5 minutes. You can now open your draft control to the desired setting.

E. Ash Removal and Disposal

Regularly inspect the ash build-up in your stove and remove as necessary. Ashes should be placed in a metal container with a tight fitting lid. Pending final disposal, the closed container of ashes should be placed on a non-combustible floor or on the ground, away from all combustible materials. The ashes should be retained in the closed container until all cinders have thoroughly cooled. Whether you have a masonry or pre-manufactured flue system, it is essential your chimney and connector pipe be inspected and cleaned as required for creosote build-up. Your system should be inspected for creosote twice a month.

SECTION 6: CARE AND MAINTENANCE

A. Catalytic Combustor Maintenance

Note – Your unit will have a 3” thick, 25-cell combustor (manufactured by Applied Ceramics), **or** it will have a 1” thick, “ceramic foam” type combustor (manufactured by Clear Skies). The following instructions apply to both types, unless otherwise specified.

1. To reach the combustor, first take out the Flame Impingement Plate by removing the four (4) 3/8” brass nuts (they take a 9/16” wrench). Once the nuts are removed the plate should drop from the four bolts. This will allow you to see the bottom of your catalytic combustor.
2. *For 25-cell Applied Ceramics combustor:* If the combustor is plugged up you will see black soot within the cells on the bottom side of the ceramic piece. This can usually be removed by brushing the combustor with a soft bristled brush. You can also run a pipe stem cleaner through each cell for removal of any internal build-up. This type cleaning can be done without removing the combustor from the stove. *For 1” thick Clear Skies combustor:* Follow the instructions provided by Clear Skies pertaining to the cleaning of their combustor.
3. Combustor Housing (Part #CA-1710) – This cast iron housing holds the combustor in place and if it becomes cracked or broken it should be replaced (See Catalytic Combustor Replacement”).
4. Flame Impingement Plate (Part #IP-24AC) - These units are equipped with a flame impingement plate designed to keep the flames from directly hitting the combustor, which also aids in heating up gases before they reach the combustor. If this plate becomes distorted, it should be replaced (See Step 1, above).
5. The catalytic combustor (Part #AC-6C3) is guaranteed by Applied Ceramics or Clear Skies, the manufacturers. A separate warranty card will be in the manual for this part and should be mailed back to the combustor manufacturer. Both combustors are equivalent, and in the event there is a problem with this item, the manufacturer should be contacted as listed below.

Applied Ceramics
Customer Service Dept.
P.O. Box 29664

Clear Skies Unlimited, Inc.
11208 Cochiti SE
Albuquerque, NM 87123

Atlanta, GA 30359
(1-770-448-6888)

(1-505-237-9519)

B. Catalytic Combustor Replacement

1. First, remove the Flame Impingement Plate from the underside of the combustor plate. (See Catalytic Combustor Maintenance, Step 1, above.)
2. After this plate has been removed you will see four (4) more 3/8" brass nuts (they take a 9/16" wrench) holding the combustor in place. Remove these nuts, allowing the combustor collar to drop down, then remove the combustor housing.
3. The old combustor is seated in the combustor housing, and it may be necessary to use a hammer to break the old combustor out. Replace the old part with a new AC-6C3 Catalytic Combustor. It is important to purchase the combustor from your local dealer or from our factory because this part has a special interam gasket around the combustor. You may also need four (4) new brass nuts to reinstall the combustor housing.
4. After the combustor collar has been placed into the housing, carefully place the housing back into the combustor plate using four (4) 3/8" brass nuts (they take a 9/16" wrench). Bolt the housing in place and replace the flame impingement plate.

C. Gaskets

Each unit comes with a gasket kit around the door that should be replaced every two years. To replace the gasket, pull the old gasket from the channel frame, using a flathead screw driver to scrape the old gasket and cement from the channel frame. Place the new gasket in the frame and allow the adhesive to set 24 hours before building a fire.

If you have a glass in the door it may be necessary to replace the window gasket, which can only be done with the glass removed from the stove. To replace it, pull off the old gasket and scrape off the old adhesive. The AC-GGK Glass Gasket Kit has adhesive on one side of the gasket; peel off the paper (adhesive side) a little at a time and form a "U" with the adhesive side on the edge of the glass. Start at one corner and go all the way around the outer perimeter of the glass forming the "U" as you go. Cut off the excess gasket and place the glass back in the door. The replacement door gasket kit for your stove is AC-DGKC and can be purchased from your local dealer or from our factory at (Parts Orders only – 800-516-3636).

D. Firebrick

The stove is equipped with high density, high temperature firebrick. If the bricks become chipped or cracked, especially on the sides of the firebox, they should be replaced and can be purchased from your local dealer or from our factory. The stove requires seven (7) small brick (Part #AC-SB) and fourteen (14) large brick (Part #AC-LB).

E. Finish

This product has been painted with 1200 degree Fahrenheit Metallic Charcoal paint which will retain its original look for several years; however, if your unit should get wet some rust spots may appear. Use steel wool to remove the rust and repaint this area with our paint: Part # AC-MCSP (or AC-MBSP if you have a black painted unit). When you repaint, use only this paint because other paints may not adhere to the stove surface. You can purchase the paint from your local dealer or from our factory at (Parts Orders only – 800-516-3636).

F. Blower System

The 24-ACD, 50-SHW24 and 50-TRW24 have a tube type blower system that consists of a manifold welded into the inner-top of the firebox chamber. If you notice smoke coming from one of the four (4) blower tubes, put the fire out and contact the factory. The manifold system is covered by the factory warranty.

At the rear of the unit is a blower duct, and at the bottom is a flange for the AC-16 blower motor connection. The AC-16 is a squirrel cage blower that has two (2) oil ports on the motor housing, (one over each bearing). Prior to each heating season you should place three (3) to four (4) drops of light sewing machine type oil in each port, and you should check the intake blower to be sure it is not clogged with lint or dust. If it is clogged, unplug the unit from the power source, and remove the motor and impeller by removing the two (2) sheet metal screws from the squirrel cage. Clean the impeller and inside the squirrel cage and replace the motor and impeller.

G. Glass Cleaning

Note: Glass is standard on the 24-ACD/FC, 50-SHW24/16 and 50-TRW24/16

It will be necessary to clean the glass two or three times a week, depending on the type wood you are using and the mode in which you are operating the stove. To clean the glass let the unit cool down, open the door and use a stove glass cleaner or ammonia mixed with water.

SECTION 7: CHIMNEY AND FLUE PIPE MAINTENANCE

A. Chimney and Flue System Maintenance

Cleaning your chimney is not a difficult task, and some stove owners choose to inspect and clean their own flue system. However, many owners will contact a local chimney sweep to inspect and clean their flue system. We highly recommend you have a professional chimney sweep inspect and clean your flue system -- remember, a professional can spot problems you may overlook.

B. Flue Pipe Maintenance

Whether you are connecting your freestanding unit to a masonry or pre-manufactured chimney system, you should have 24 gauge or thicker single wall pipe to connect your stove to the flue system. This pipe requires a certain amount of maintenance. You should clean the pipe, as needed, usually just after the heating season or just before the coming heating season. This pipe will eventually need to be replaced, depending on the thickness of the pipe (thicker pipe will last longer).

NOTE: It is a good idea to clean your chimney and flue pipe in the spring to eliminate any lingering odor through the summer months.

SECTION 8: THINGS THAT COULD CAUSE YOUR STOVE TO SMOKE

It is of the utmost importance that installations are made airtight. This is best accomplished by using furnace cement at each joint and where the elbow or first joint of pipe enters the heater and chimney flue. Any existing air leaks will cause the draft to draw at points where the least resistance is offered – such places are the joints where pipe enters the chimney flue; around a loose flue thimble, or flue openings into the chimney; around clean out doors into the chimney; and where decayed matter has fallen out, permitting air to enter the chimney. When this takes place, the gases and smoke are not drawn off the stove in proper quantity, causing them to build up in volume within the stove, which results in “back puffing.” All such leaks must be sealed off airtight. In other words, the entire chimney “pull” or “draft” must be only on the draft entrance.

There are two main reasons for chimney down draft. One is from air currents being deflected down the chimney by nearby objects such as a tree, building or hill. The other reason, equally or more common, is that in many chimneys the flue gases are chilled too quickly as they pass up the chimney. The temperature of the flue gases drop and they become heavy. As other gases from the fire attempt to push up the flue they hit the heavy air and then tend to back up in the flue system; this often results in back puffing, back pressure, odors in the house or poor combustion, all of which can be very annoying. If you have a smoking problem that you cannot correct, consult your local dealer for assistance or call the Customer Service Department at our factory.

HEAT SHIELD INSTALLATION

Freestanding models have weld nuts on the rear of the units for attaching optional Heat Shields. By using an Add-on Heat Shield, you will be able to reduce your clearance to combustibles to six inches (6”) in conjunction with double wall or shielded pipe.

Both the AC-AHS/SH-HS22 and the AC-FHS(B) Side and Rear Heat Shields attach to the rear of the unit and wrap around the sides. The sides of the stove not covered by the Heat Shield will require thirty inches (30”) of clearance to a combustible surface.

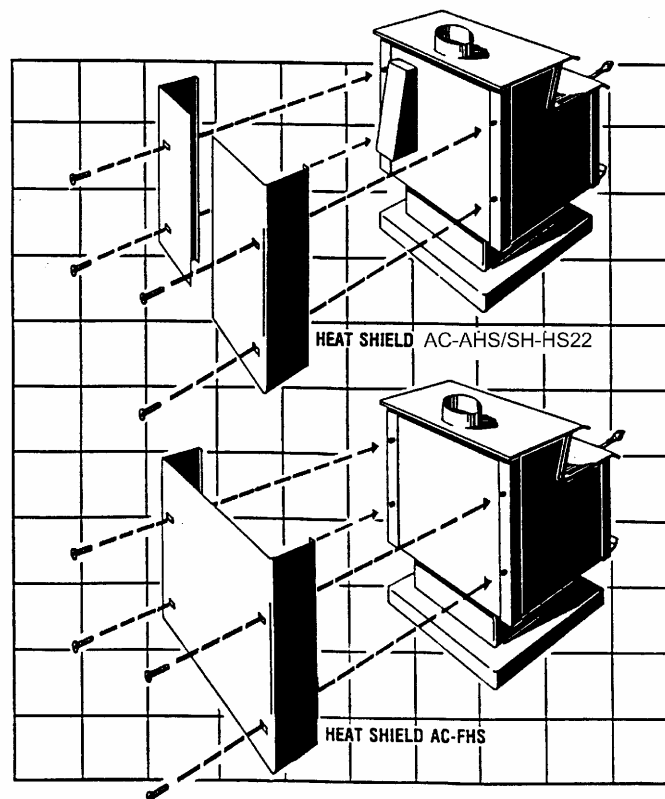

HAVE THIS INFORMATION ON HAND IF YOU PHONE THE FACTORY OR THE DEALER REGARDING THIS PRODUCT.

Retain for your files:

Model Number _____

Date of Purchase _____

Date of Manufacture _____ **Serial #** _____

**LIMITED 5 YEAR WARRANTY
FROM THE DATE OF PURCHASE TO THE ORIGINAL OWNER**

The manufacturer extends the following warranties:

Five Year Period:

1. Carbon steel and welded seams in the firebox are covered for 5 years against splitting.
2. The cast iron door, hasp and hinges are covered for 5 years against cracking.

One Year Period:

3. Component parts such as combustor housing, flue collar, flame impingement plate, baffle plate, brick retainers, combustor plate and fasteners are covered for 1 year against cracking, breakage and welded seams from separating.
4. Electrical components, accessory items, glass and the painted surface are covered for 1 year from the date of purchase.

Conditions and Exclusions:

Damage from over-firing will void your warranty.

This warranty does not apply if damage occurs because of an accident, improper handling, improper installation, improper operation, abuse, or unauthorized repair made or attempted to be made.

The manufacturer is not liable for indirect, incidental, or consequential damages in connection with the product including any cost or expense providing substitute equipment or service during periods of malfunction or nonuse.

All liability for any consequential damage for breach of any written or implied warranty is disclaimed and excluded. Some states do not allow the exclusion or limitations of incidental or consequential damages, so the above may not apply to you.

Procedure:

Purchaser must give notice of claim of defect within the warranty period and pay transportation to and from a service center designated by the factory. The dealer from which the unit was purchased or the factory, at our option, will perform the warranty service.

Other Rights:

This warranty gives you specific legal rights, and you may also have other rights, which may vary from state to state.

NOTE: THIS WARRANTY IS NULL AND VOID IF YOU DO NOT RETURN THE ATTACHED WARRANTY REGISTRATION WITH A COPY OF THE SALES RECEIPT WITHIN 30 DAYS FROM THE DATE OF PURCHASE. WARRANTY IS NOT TRANSFERABLE.

REPLACEMENT PARTS and OPTIONS LIST

OPTIONS:

AC-13	Catalytic Thermometer
AC-102/SH-102	Brass Lip & Ash Apron Trim
AC-102BN	Brushed Nickel Lip & Ash Apron Trim
AC-106-P/SH-106-P	Brass Window Trim (24-ACD/FC, 50-SHW24/16 or 50-TRW24/16)
AC-106-PBN	Brushed Nickel Window Trim
AC-FHS	Side and Rear Heat Shield (24-FC, 50-SHW16 or 50-TRW16)
AC-FHSB	Side and Rear Heat Shield (Black, for 50-SHW16L)
AC-AHS/SH-HS22	Side & Rear Heat Shield (24-ACD, 50-SHW24 or 50-TRW24)

NOTE: You must use the top vent option of your unit when using heat shields.

REPLACEMENT PARTS:

AC-G9	9" x 9" Glass with Gasket
AC-16	Complete Blower Assembly (24-ACD, 50-SHW24 or 50-TRW24)

NOTE: The 24-FC, 50-SHW16, 50-SHW16L and 50-TRW16 are not blower adaptable (cannot use the blower)

AC-DGKC	Door Gasket Kit
AC-FCGK	Flue Collar Gasket
AC-SB	9" x 4" x 1.25" Firebrick (7 Required in bottom)
AC-LB	9" x 4" x 2.25" Firebrick (14 Required –sides & back)
AC-SH	Spring Handle – Door
AC-6C3	Catalytic Combustor
AC-MCSP	Hi-Temp Metallic Charcoal Paint
AC-MBSP	Hi-Temp Black Paint
CA-1710	Combustor Housing
CA-20	6" Flue Collar (Incl. Gasket & Hardware)
CA-22	6" Blank (Incl. Gasket & Hardware)
CA-24	Cast Iron Draft Cap
IP-24AC	Flame Impingement Plate

All replacement parts can be ordered from our factory at (Parts Orders ONLY): 1-800-516-3636, or from our web site: www.englishstoveworks.com .

If you have any problems or questions call the Customer Service Department.

Customer Service Department service@englanderstoves.com
P.O. Box 206 **Parts Orders ONLY: (800-516-3636)**
Monroe, Va 24574 **Tech. Questions/Problems: (800-245-6489) (Fax: 434-929-4810)**

WARRANTY REGISTRATION for England's Stove Works

Purchased by (Name) _____

Address _____

City _____ State _____ Zip _____

Telephone _____

Email Address _____

DEALER INFORMATION

Purchased From (Dealer) _____

Address _____

City _____ State _____ Zip _____

UNIT INFORMATION

(Please be sure to refer to sticker on back of manual or box to complete this section)

Model Number _____ Purchase Date _____

Purchase Price _____

Serial Number _____ Mfg. Date _____

How did you first hear about our product? (please check one)

Word of Mouth Burn Trailer Demonstration Internet

Other: _____

Where did you receive information about our product? (please check one)

Rec'd. info. via phone Dealer (Name of dealer): _____

Internet Other: _____

IMPORTANT NOTICE

**THIS REGISTRATION INFORMATION MUST BE ON FILE FOR THIS WARRANTY TO BE VALID.
PLEASE MAIL THIS INFORMATION WITHIN THIRTY (30) DAYS FROM THE DATE OF PURCHASE.**

Mail To:

England's Stove Works, Inc.
Customer Service Department
P.O. Box 206
Monroe, VA 24574

Or, Fax To:

(434) 929-4810 – 24 hours a day

Or, now available – Go online to complete your Warranty Registration!

Visit www.englishstoveworks.com if you prefer to register online.