

INSTALLATION & OPERATION MANUAL

MODEL NUMBERS: 10-CDV 49-TRC22 49-SHC22

*Thank you for purchasing this product from a fine line of heating equipment.
We wish you many years of safe heating pleasure with your new heating appliance.*

Save These Instructions.

IMPORTANT: IF YOU HAVE A PROBLEM WITH THIS UNIT DO NOT RETURN IT TO THE DEALER. CONTACT CUSTOMER SERVICE @ 1-800-245-6489.

Mobile Home Use:

These freestanding corn/pellet units are approved for mobile home or doublewide installation with outside combustion air hook-up. See "Flue System" section of manual.

Mobile home installation should be in accordance with the Manufactured Home and Safety Standard (HUD), CFR 3280, Part 24.

WARNING: Do Not Install in Sleeping Room

CAUTION: The structural integrity of the mobile home floor, wall and ceiling/roof must be maintained.

Please Note the Following Precautionary Statements:

NOTE: WE DO NOT RECOMMEND CORN/PELLET STOVES AS YOUR ONLY SOURCE OF HEAT.

England's Stove Works highly recommends the use of smoke detectors and Carbon Monoxide detectors with any hearth product, including this unit. Follow all manufacturer's instructions when using smoke or Carbon Monoxide detectors.

CAUTION: Please read this entire manual before installation and use of this corn/pellet/ fuel burning room heater.



Keep children, furniture, fixtures and all combustibles away from any heating appliance.

WARNING: USE OF OUTSIDE AIR IS MANDATORY WITH THIS UNIT.

DO NOT OPERATE UNIT WITH HOPPER OPEN. LID MUST BE SHUT AND TIGHTLY SECURED.
DO NOT OPERATE WITH DOOR OPEN

SAFETY NOTICE

FAILURE TO FOLLOW THESE INSTRUCTIONS COULD RESULT IN PROPERTY DAMAGE, BODILY INJURY OR EVEN DEATH. FOR YOUR SAFETY AND PROTECTION, FOLLOW ALL THE INSTALLATION INSTRUCTIONS. CONTACT YOUR LOCAL BUILDING OR FIRE OFFICIALS FOR RESTRICTIONS AND INSTALLATION INSPECTION REQUIREMENTS (INCLUDING PERMITS) IN YOUR AREA.

Questions? Need Parts or Options? www.englishstoves.com



A letter from our Technical Support department:

Thank you for purchasing this fine product from England's Stove Works!

England's Stove Works was started, and is still owned by, a family that believes strongly in a "Do It Yourself" spirit – that's one reason you found this product at your favorite "Do It Yourself" store.

We intentionally design and build our stoves so that any homeowner can maintain his or her unit with basic tools, and we're always more than happy to show you how to do the job as easily and as inexpensively as possible.

From our free, downloadable service sheets; to our Corn and Pellet Service Videos; to our new "wizard-style," click-through Troubleshooting guide on our web site, we have always tried to help our customers stay "heat-ready," especially while oil and electricity prices continue to skyrocket.

Please look at our vast Help section on our web site and call our Customer Service department at (800) 245-6489 if you need any help with your unit. We are nearly always able to help "walk you through" any repairs, problems or questions you may have.

PLEASE NOTE: While information obtained on our web site and through our 800 number is always free of charge, there will be a service charge incurred with any "on-site" repairs or maintenance that we may arrange.

Wishing you years of efficient, quality and "comfy" heating,

England's Stove Works
Technical Support Department

www.englishstoves.com

(800) 245-6489

<p>IF YOU HAVE A PROBLEM WITH THIS UNIT DO NOT RETURN IT TO THE DEALER. CONTACT CUSTOMER SERVICE at 1 (800) 245-6489.</p>

IMPORTANT INFORMATION

1. Installation of this pellet/corn unit should be performed by a professional only. Check local installation codes for your area. Call your Homeowner's Insurance representative for inspection of your stove's installation.
2. Read and comply with the instructions in this manual.
3. This unit should be tested (dry run) for 20 minutes before loading corn or pellets. The stove should automatically shut itself off after the 20-minute dry run.
4. **If burning pellets instead of corn, you should use Premium Pellets, as this stove is designed for Premium Pellets.** Pellets with high ash content will burn dirty and require the unit to be cleaned more often.
5. Be sure your corn or pellets are not damp or wet. If your corn is too damp, this stove may not be able to run on the lower Heat Range settings (the fire will die out). Be sure to keep sawdust out of the unit.
6. Use three-inch (3") U.L.-approved CORN VENT TWIST-LOCK PIPE when installing this stove and follow the manufacturer's specifications for installation and clearances (we highly recommend Simpson Dura-Vent corn twist-lock pipe). Even though this pipe interlocks, it is a good idea to seal all connections with high temperature silicone. Use at least three screws to secure the pipe to this unit's exhaust blower. Also, if you do not use U.L.-approved twist-lock corn pipe, be sure to use U.L.-approved Corn Vent pipe, and fasten each joint of the pipe with at least three screws.
7. Outside combustion air is mandatory for these units to work properly. Make this connection using a 1 ⁷/₈" I.D. metal pipe (steel, aluminum or copper) and coupler. Be sure to secure the pipe to the unit with a clamp or aluminum tape. The outside end should be covered (screened) to prevent any foreign matter from entering the system. Try to keep the number of bends in this pipe to a minimum. Our Part Number PU-OAK (Outside Air Kit with flex pipe) can be used.
NOTE: If the total run of the connection exceeds 6', use 3" metal pipe and coupler instead.
8. Regularly inspect the Burnpot area and, if any crust forms, remove it with a poker.
9. The ash in the Firebox should be removed regularly, depending on your burn rate. The area to the right and left of the Burnpot is for ash storage; keep the air holes in the Burnpot clean for a more efficient burn. Check your exhaust system frequently. Refer to "Ash Removal and Disposal" section.
10. Keep corn, pellets and all other combustible materials a safe distance from the unit.
11. This unit will require floor protection if installed on a combustible surface. The minimum floor protector for this unit is 36" x 36" which should give you at least six inches (6") of protection at the rear and at each side, and six inches (6") minimum in the front of the unit.

12. Horizontal runs should not exceed four feet (4') with a maximum vertical flue height of thirty five feet (35'). At fifteen feet (15'), the pipe should be increased to four inch (4") corn vent pipe.
13. This unit should be turned off and allowed to cool prior to cleaning. Any ashes should be kept in an airtight metal container and not disposed of until they are completely cooled.
14. Read the instructions thoroughly, including instructions concerning the digital control board, and save them for future reference.
15. Do not allow paint, chemicals or construction dust on or near your unit. Do not allow liquid or ANY foreign materials on or inside your unit. Shut your unit down and cover it when painting, construction or similar activity is taking place. Wipe and clean your unit after any construction is done in your home, or if any foreign material gets on or inside your unit. You may also need to remove the rear and side cover plates to your unit (unplug unit first) and vacuum and clean the motors and inside of your unit.
16. Improper gasket maintenance, including failure to replace gaskets, can cause air leaks resulting in smoke-backs.
17. Remember that, as with any appliance, there is user responsibility involved, including installation, operation and maintenance of this product. Be sure to check local codes, and call Customer Service at (800) 245-6489 if you have any questions.
18. **Be sure to follow the directions of all manufacturers of third party products that you use, including exhaust pipe, etc. Never apply firestarter products (including gel) to a hot surface or hot coals.**
19. **Basement Installation:** Basement installation should be performed only by a professional installer. For basement installations, a 3" (three inch) pipe and coupler must be used for Outside Combustion Air, and a minimum clearance of 3' (three feet) must be maintained from the ground to the corn vent exhaust pipe outside the dwelling. Keep in mind that each elbow used reduces draft by up to 30%; it is good practice to add 3' (three feet) of vertical rise for each elbow used. Example: After the 2nd elbow used, add 6' (six feet) of vertical rise before terminating your vent pipe.
20. **DANGER!** Do not open the door on this unit if the Stirrer is still moving! See instructions on "Setting the Stirrer" later in this manual.

IMPORTANT NOTICE:

This unit must be properly installed to prevent the possibility of a house fire or "smoke-back." The instructions must be strictly adhered to.

Do not use makeshift methods or material which may compromise the installation.

Your unit requires periodic maintenance and cleaning (refer to manual). Failure to maintain your unit may lead to a variety of problems, including but not limited to smoke spillage into the home. England's will not be liable for consequential or indirect damages to property or persons resulting from the use of this product.

UNIT PREPARATION

1. Attach the spring handle to the door by turning it counterclockwise. **Important: Also check hopper latch – must be tight so that the top is sealed to prevent back-burn.**
2. Test your 110-volt outlet for current and then plug in the unit. **(We highly recommend a surge protector for our unit, as the control panel is electronic).**
3. Be sure to “dry run” your unit for 20 minutes before connecting it to the flue. During this time the blowers and auger will operate at different times throughout the 20-minute period (it should stop automatically after 20 minutes).

Visit our web site at www.englanderstoves.com for helpful information, frequently asked questions, parts/accessory orders and more!

IMPORTANT INFORMATION – READ BEFORE OPERATING

- When installing your corn/pellet stove, particular attention needs to be made in regards to fire protection. If the unit is not properly installed, a house fire may result. For your safety, follow the installation and operation instructions provided, and if a question arises contact local building or fire officials about restrictions and installation requirements in your area.
- Read the Operations and Fuel section of this manual before plugging in your unit.
- Always unplug the unit before attempting any service work.
- Do not connect the unit to a chimney flue already serving another appliance.
- When installing the chimney pipe to the unit, it is important to remember that the unit operates on negative pressure and the chimney on positive pressure. All chimney connections, elbows, and fittings must be air-tight. **(Proper venting practices must be followed. Consult with a venting professional.)**
- Ashes must be disposed of in a metal container with a tight fitting lid.
- **All** minimum clearances to combustibles **must** be followed.
- The corn/pellet stove is tested for operation with corn with **14% or less** moisture content; it is recommended that corn with **11-12%** moisture be used for most efficient operation of this unit. **Corn with over 12% moisture has a lower BTU value and will hard to burn on the lower settings.**
- **It is important to use fuel that is clean, dry and consistent.** It is recommended that you purchase your entire heating season supply of fuel at one time, to make sure it is the same.

- Corn must be clean and free from debris; never burn corn straight from the field. Stalk parts, excessive fines and cob remnants, etc. will clog the auger mechanism. We highly recommend the use of a sifter; sifters to filter your corn are available from dealers (and we offer a sifter at www.englishstoves.com). Damage caused by dirty and/or unfiltered (unsifted) corn is not covered by the product warranty – ask for and use clean filtered bagged corn only.
- **DISCLAIMER NOTICE:** No guarantee is made regarding the heating capacity of this product. The actual area that this unit will heat depends on factors such as building conditions, heat loss, type of construction, amount and type of insulation, type of air movement and heat distribution, and the location of the product.
- **Important:** Your home must be checked to verify that there is no negative pressure that will affect the operation of this appliance.
- **IMPORTANT: DO NOT BURN “TREATED” SEED CORN IN YOUR STOVE.** Seed corn is treated with chemical pesticides that are harmful or fatal if swallowed; therefore, seed corn is dangerous to have in the house, especially where children can reach it. **Burning treated seed corn in your stove will void your warranty and will destroy the exhaust system on the unit.**
- There are many varieties of corn grown around the world. Each variety has unique characteristics including the shape and size of the kernel. Your stove will burn more consistently with a small to medium kernel corn. If the kernel size of the corn varies greatly or if you switch sources frequently, you will get a less consistent burn. **Do not use corn with high wax content.**
- Vacuum the hopper out after every 6-8 bags to eliminate buildup of saw dust and fines from corn.

Notes on termination of Vent Pipe (see also “FLUE SYSTEM” section of manual):

1. Not less than three (3) feet above any forced air inlet located within ten (10) feet.
2. Not less than four (4) feet below, four (4) feet horizontally from, or one (1) foot above any door, window or gravity air inlet into any building.
3. Not less than two (2) feet from an adjacent building, and not less than seven (7) feet above grade where located adjacent to public walkways.

The exhaust exit shall be arranged so that the flue gases are not directed so that it will affect people, overheat combustible structures, or enter buildings. Forced draft systems and all parts of induced draft systems under positive pressure during operation shall be installed gastight or to prevent leakage of combustion products into a building. Through-the-wall vents shall not terminate over public walkways, or where condensate or vapor could create hazards or a nuisance.

*Be sure to follow local codes and all manufacturer's instructions (including exhaust pipe).
Consult a professional installer and/or call Customer Service if you have any questions.*

**NOTE: YOUR UNIT MUST BE INSTALLED BY A QUALIFIED
INSTALLER, SUCH AS AN NFI CERTIFIED SPECIALIST**

GUIDELINES FOR EXHAUST VENTING SYSTEMS DESIGN

INSTALL VENT AT CLEARANCES SPECIFIED BY THE VENT MANUFACTURER

- A UL listed three-inch or four-inch (3”or 4”) type “PL” pellet vent exhaust system must be used for installation and attached to the pipe connector provided on the back of the unit. Use a three-inch to four-inch (3” to 4”) adapter for four-inch (4”) pipe. A cap must be used at the termination of type “L” vent chimneys. Four-inch (4”) PL is recommended for elevations above 2,500 feet above sea level.
- Do not terminate vent in any enclosed or semi-enclosed area, such as: carports, garage, attic, crawl space, under a deck or porch, walkway or close area or any location that could build up a concentration of fumes such as a stairwell, covered breezeway, etc.
- Vent surfaces can get hot enough to cause burns if touched by children. Non-combustible shielding or guards may be required.
- Do not install a flue damper in the exhaust vent of this unit.
- Termination must exhaust above air inlet elevation. Installation MUST include three (3) vertical feet of pellet vent pipe. This will create some natural draft to prevent the possibility of smoke or odor during unit shutdown, and keep exhaust from causing a nuisance or hazard from exposing people or shrubs to high temperatures. **DO NOT CONNECT THIS UNIT TO A CHIMNEY FLUE SERVICING ANOTHER APPLIANCE. DO NOT CONNECT DIRECTLY TO A MASONRY CHIMNEY.**
- Distance from doors and windows, gravity or ventilation air inlet into building: not less than four feet (4 ft.) below, four feet (4 ft.) horizontally from, one foot (1 ft.) above (this does not apply if the windows are non-opening or have been fixed so they cannot open).

- Distance from bottom of termination and grade - one foot (1 ft.) minimum. This is conditional upon the plants and nature of the grade surface. The exhaust gases are hot enough to ignite grass, plants, shrubs, etc. located in the vicinity of the termination. The grade must not be a lawn. Distance from bottom of termination and public walkways is seven feet (7 ft.) minimum.
- Distance to combustible materials – two feet (2 ft.). This includes adjacent buildings, fences, protruding parts of the structure, roof overhang, plants and shrubs, etc.
- The installation must include a cleanout tee to enable the collection of fly ash and permit periodic cleaning of the exhaust system. 90° elbows accumulate fly ash and soot, thereby reducing exhaust flow and performance of the unit. Each elbow or tee reduces draft potential by up to 30%.
- Total length of horizontal vent must not exceed 48” (4 ft.). All joints in the vent system must be fastened by at least 3 screws, and all joints must be sealed with RTV silicone sealer to be air-tight.
- The “PL” vent or single wall stainless exhaust system must be installed so as to be GAS TIGHT! Follow the vent manufacturer’s installation instructions.
- The area where the vent pipe penetrates the exterior of the home must be sealed with silicone or other means to maintain the vapor barrier between the exterior and the interior of the home.

NOTE: These are guidelines only. Proper venting is accomplished by design and common sense. In most installations, three-inch (3”) diameter venting is adequate. If it does not vent properly, you will have to change it to four-inch (4”) diameter venting.

DO NOT CONNECT TO ANY AIR DISTRIBUTION DUCT OR SYSTEM.

BURNING SOLID FUELS

Ashes will need to be removed from the unit periodically. See Ash Removal section. You can minimize cleaning required and maximize efficiency by maintaining the proper draft.

This unit has been designed to burn dry shelled corn or premium hardwood pellets that meet the association of pellet fuel industry standards.

Shelled corn (dry, preferably corn with 11-12% moisture content)

Never burn “deer corn” as it frequently contains molasses/sugars.

Store your corn supply in a dry place and keep bags or container sealed to prevent your corn from absorbing excess moisture. Test the moisture content regularly to ensure proper dryness.

IMPORTANT: DO NOT BURN “TREATED” SEED CORN IN YOUR STOVE. Seed corn is treated with chemical pesticides that are harmful or fatal if swallowed; therefore, seed corn is dangerous to have in the house, especially where children can reach it. **Burning treated seed corn in your stove will void your warranty and will destroy the exhaust system on the unit.**

WOOD PELLETS

As with corn, be consistent in your choice of wood pellet supplier. Pellets will vary in content and burn characteristics from supplier to supplier.

- Check your pellets for foreign objects. Your stove warranty will not cover any damage caused due to foreign objects in the fuel supply.
- Store your pellets in a dry place to prevent them from absorbing added moisture.
- To decrease sawdust buildup, the hopper will need to be vacuumed out after every 6-8 bags of pellets, or more often if the quality of the pellets are poor. You may need to screen each bag of pellets if the sawdust becomes a problem.
- Wood pellets vary in size and also ash content (from less than 1% to 3% or more). Your unit will burn more efficiently with small to mid-size pellets. Low ash content pellets will allow you to burn the stove longer between cleanings.
- Your unit is designed to burn pellets that are no larger than one-quarter inch (¼”) in diameter, and no longer than two and one-half inches (2 ½”) long.

CAUTION: DO NOT PLACE SUCH FUELS WITHIN THE SPACE HEATER’S INSTALLATION CLEARANCES OR WITHIN THE SPACE REQUIRED FOR CHARGING AND ASH REMOVAL.

SETTING THE STIRRER

- **Warning: Do not open the door on this unit if the Stirrer is still moving!
Bodily Injury can occur!**

The Stirrer may be turned Off by pushing the “Air On” button on the bottom of the Control Panel, and then pressing the Down arrow on the “Blower Speed” until you see a “0” in the Blower Speed window.

The Stirrer may be turned back On by pressing the “Air On” button on the bottom of the Control Panel, and then pressing the Up arrow on the “Blower Speed” until you see a “1” in the Blower Speed window.

FLUE SYSTEM

Caution: Follow the pipe manufacturer's installation instructions and directions for passing through combustible walls and ceilings.

Be sure to check local codes in your area.

NOTE: See the installation drawing later in this manual (Illustration 1).

This unit is equipped with a negative draft system that pulls combustion air through the Burnpot and pushes the exhaust air out of the dwelling. If this unit is connected to the flue system other than the way explained in this manual, it will not function properly. For any of these installations, keep in mind that each elbow used reduces draft by up to 30%; it is good practice to add 3' (three feet) of vertical rise for each elbow used. Example: After the 2nd elbow used, add 6' (six feet) of vertical rise before terminating your vent pipe.

Corn Vent Pipe

The UL approved corn vent pipe that we recommend is a twist lock system; however, it is still recommended that high temperature silicone be used at each joint. England's Stove Works recommends the use of Simpson Dura-Vent® twist-lock pipe (if you use other pipe, consult your local building codes and/or building inspectors, and secure each joint with at least three screws—see Important Information, above). *Do not* use "B" vent gas pipe or galvanized pipe with this unit. The corn pipe is designed to disassemble for cleaning and should be checked several times during the burning season — corn vent pipe is not furnished with the unit and must be purchased separately. **Do not install a flue damper of any kind in this system, and do not connect this unit to a flue system serving another heating appliance.**

Through the Wall

To vent the unit through the wall, connect the pipe adapter to the exhaust motor adapter. If the exhaust adapter is at least eighteen inches (18") above ground level, a straight section of corn pipe can be used to initially pass through the wall (see **Illustration 1**). Your dealer or our factory should be able to provide you with a kit that will handle most of this installation, which will include a wall thimble that will allow the proper clearances through a combustible wall. Once outside the structure, a three-inch (3") clearance should be maintained to the outside wall and a clean out tee should be placed on the pipe that extends through the wall. We recommend a minimum of three feet (3') of vertical pipe with a 90-degree turn away from the house. At this point, a one-foot (1') section and horizontal cap will complete the installation (see **Illustration 1**).

A wall strap should be placed just below the last 90-degree section to make the system more stable. If you live in an area that has heavy snowfall, it is recommended the installation be taller than three feet (3') to get above the snowdrift line.

The same type installation can be used if your stove is below ground level by adding the clean-out section and vertical pipe inside until ground level is reached. However, we recommend basement installation be performed only by a professional installer. For basement installations, a 3" (three inch) pipe and coupler must be used for Outside Combustion Air, and a minimum clearance of 3' (three feet) must be maintained outside the dwelling from the ground to the Corn Vent Exhaust Pipe.

The through-the-wall installation is the least expensive and simplest installation. In a through-the-wall installation you should be mindful of the snowdrift line, as well as dead grass and leaves. We recommend a three foot (3') minimum vertical rise on the inside or the outside of the dwelling. Never terminate the end vent under a deck, in an alcove, under a window or between two windows.

Call **(800) 516-3636** to inquire about the AC-33000 Through-the-Wall Kit or
Visit our web site at www.englishstoves.com for ordering information!

Through the Ceiling

When venting the stove through the ceiling, the pipe is connected the same as through the wall, except the clean out tee is always on the inside of the house, and a 3" adapter is added before the clean-out tee. You must use the proper ceiling support flanges and roof flashing supplied by the pipe manufacturer -- follow the pipe manufacturer's directions and **Illustration 1** in this manual. It is important to note that if your vertical runs of pipe are more than fifteen feet (15') at this point, the corn vent pipe should be increased to four inches (4") in diameter. Do not exceed four feet (4') of pipe on a horizontal run, and do attempt to use the least number of elbows in the flue system. If an offset is used it is better to install a 45-degree elbow whenever possible. *Please remember, installing elbows may inhibit your draft by up to 30% per elbow.*

Outside Air (Outside Combustion Air Intake)

Outside air is mandatory for this unit to operate properly. This unit has been designed and tested with this connection, because so many homes are airtight and there is not adequate combustion air available inside the dwelling. The air intake pipe is located on the bottom side of the Burnpot (from the rear) and measures 1 ½" inside diameter (I.D.). The connection can be made with a metal 1 7/8" I.D. coupler and pipe (see "Important Information" section of manual), and should exit through the wall. Be sure to secure the pipe to the unit with a clamp or aluminum tape. The outside end of the pipe should be covered (screened) to prevent foreign matter from entering the system. Our Outside Air Kit (Part Number PU-OAK) can be used. If the unit is located below ground level, you will need to run the pipe up and then outside the dwelling. NOTE: If the total run of the connection exceeds 6', if more than 2 elbows are used, or if a basement installation, use 3" metal pipe (and coupler) instead.

Mobile Home Installation

Secure the heater to the floor using the two holes in the pedestal. If the unit is on a combustible surface, you will need to drill matching holes in the floor protection that you choose (see Floor Protection section). Do not disturb the structural integrity of the home, and be sure the unit is permanently electrically grounded to the chassis of your home. Remember that outside combustion air is mandatory, and not to install the unit in a sleeping room of the home.

Important Notes Concerning Installation:

***IMPROPER INSTALLATION:** The manufacturer will not be held responsible for damage caused by the malfunction of a stove due to improper venting or installation. Call (800-245-6489) and/or consult a professional installer if you have any questions.

IMPORTANT: Improper hook-up (too much pipe, too many elbows, etc.) will cause the unit not to operate. Call Customer Service (800-245-6489) if you have questions about your hook-up or if your unit will not operate.

IMPORTANT SAFETY NOTE: If the unit or chimney connector pipe "glows" red (or white), the stove is over-fired. This condition could cause a house or chimney fire. Do not operate your unit too hot, or over-firing may result.

Freestanding Corn/Pellet Installation

Caution: Follow the pipe manufacturer's installation instructions and directions for passing through combustible walls and ceilings. Check local codes in your area.

Illustration 1

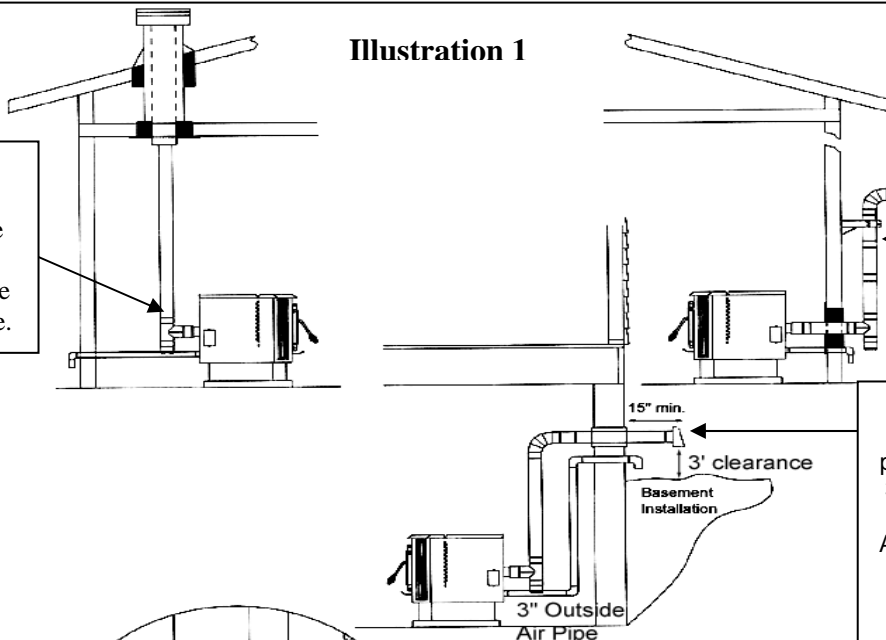

Must have minimum 3" adapter before tee for longer run. For shorter run, tee alone is acceptable.

Our Part AC-33000 is acceptable for through-the-wall installation. (We recommend 4" for 2500+ ft. installations.)

Basement Installation should be performed by professional installer. Use 3" metal pipe and coupler for Outside Combustion Air. Minimum 3' clearance from ground to the Pellet Vent Exhaust Pipe.

Outside AIR IS MANDATORY for this unit to operate properly.

1. If 3" flue pipe exceeds 15' in length, increase to 4" flue pipe for remaining flue connections.
2. Total flue length should not exceed 35'.
3. Horizontal run not to exceed 4'.
4. Floor protector required: Min. size 36" x 36".
5. If the total run of outside air connection exceeds 6', if more than 2 elbows are used, or if a basement install, use 3" metal pipe (and coupler) instead.
6. **Outside Air is mandatory for proper safe operation.**

FLOOR AND WALL PROTECTION

Floor Protection

If your floor is constructed of a non-combustible material such as brick or concrete, there is no need for floor protection. If the floor is constructed of a combustible material such as hardwood, linoleum, or carpet, then you will be required to use floor protection between the unit and the combustible. The protection should be U.L. approved or equal, and should be large enough to provide a minimum of six inches (6") behind and on both sides of the stove. The clearance in front of the stove should be at least six inches (6"). This freestanding pellet unit will need a minimum 36" x 36" floor protector.

Wall Protection

From the rear of this stove only three inches (3") of clearance is required to paneling, wallpaper or drywall. The same clearance (3") is required to a corner wall. Six inches (6") would be required to a sidewall. Alcove clearances: Six inches (6") is required to an alcove sidewall; three inches (3") is required to an alcove backwall, and seventeen inches (17") is required to an alcove ceiling. The corn vent pipe would require the standard three inches (3") clearance, or as recommended by the manufacturer. Normally additional wall protection is not required with this type unit.

OPERATING INSTRUCTIONS

CAUTION: DO NOT OPERATE WITH THE DOOR OPEN.

If door is left open (approximately) two minutes, unit will stop feeding and fire will go out.
Do not burn trash (paper bags, etc.) in this unit.

This stove has an induced draft system and is designed to operate continuously, as frequent shutdown is not required. The setting of the “**Heat Range**” touch pad will control the heat output and the amount of fuel the unit will burn (see “Control Board” section and **Illustration 4**). Note: This stove is using solid fuel and will not restart automatically.

* *NOTE: Blower Speed will automatically be adjusted to the desired Heat Range that you select.*

START- UP PROCEDURES

Caution - Never use gasoline, lantern fuel, charcoal lighter fluid, diesel fuel, or any other flammable liquid to start the fire.

When first starting your corn/pellet stove, place approximately one (1) cup of hardwood pellets in the Burnpot. Place a small amount of starter gel or fire starter on top of the pellets and light, leaving the door cracked slightly for the first 2 minutes. After the first two minutes, close the door and press the “ON” button located on the Control Panel.

The Heat Range and Blower Speed will automatically be set to setting “5,” to ensure that proof of fire is detected. During the 20 minute start-up period the user can set the controls to a desired heat setting, and *after* the 20 minute start-up the unit will operate at that user setting.

NOTE: On the “first fire” (the first time you burn the unit), the Control Panel should be set at a “5” Heat Range and “5” Blower Speed for at least 3 hours to allow the unit to “cure” as the oils from the manufacturing process burn off. Windows and doors in the home should be opened to help ventilate as these oils burn off.

NOTE: If the unit does not start, **DO NOT** try to restart the unit until it has cooled completely down. If the unit does not start or maintain a fire, you will receive an **E-2** in the Heat Range and Blower Speed window of the Control Board. If this occurs, wait until unit has cooled completely down and repeat these steps.

FUEL NOT FEEDING CORRECTLY

If the fuel is not feeding correctly, the feed auger could possibly be misaligned due to factors such as rough handling during shipping. If you suspect your feed auger is misaligned, call Customer Service at (800) 245-6489.

CORN START-UP PROCEDURE

When starting the stove with corn, push the “AIR ON TEMP” button and hold, which will rotate the Stirrer mechanism in the Burnpot. Release the button when the Stirrer is straight up (in the “12:00” position) before following the above instructions concerning placing the handful of pellets in the Burnpot and starting your fire.

Changing from Corn to Pellets

Your unit was primarily designed to burn corn, but will also burn hardwood pellets. Your unit comes ready to burn corn by default; if you would like to burn pellets in your unit, follow the steps below.

WARNING: Do not open the door on this unit if the Stirrer is still moving!
See instructions on “Setting the Stirrer” earlier in this manual.

NOTE: Before doing these steps make sure the unit is out and completely cold!!

1. Remove the Stirrer shaft (See **Illustration 2**)
2. Unplug the unit and plug back in, then press the Heat Range down and Blower Speed down buttons at the same time and release. You should see a “P” in the Heat Range window.
3. Follow lighting instructions.

PELLET START-UP PROCEDURE

NOTE: When burning only pellets, remove Stirrer from Burnpot. See **Illustration 2**. While you will not follow the instructions in the above “Corn Start-Up Procedure,” you will follow the instructions on “Changing from Corn to Pellets” and the other “Start-Up Procedures” in the preceding “Operating Instructions” section of this manual.

If the unit does not start or maintain a fire, you will receive an **E-2** in the Heat Range and Blower Speed window of the Control Board. If this occurs, wait until unit has cooled completely down and repeat.

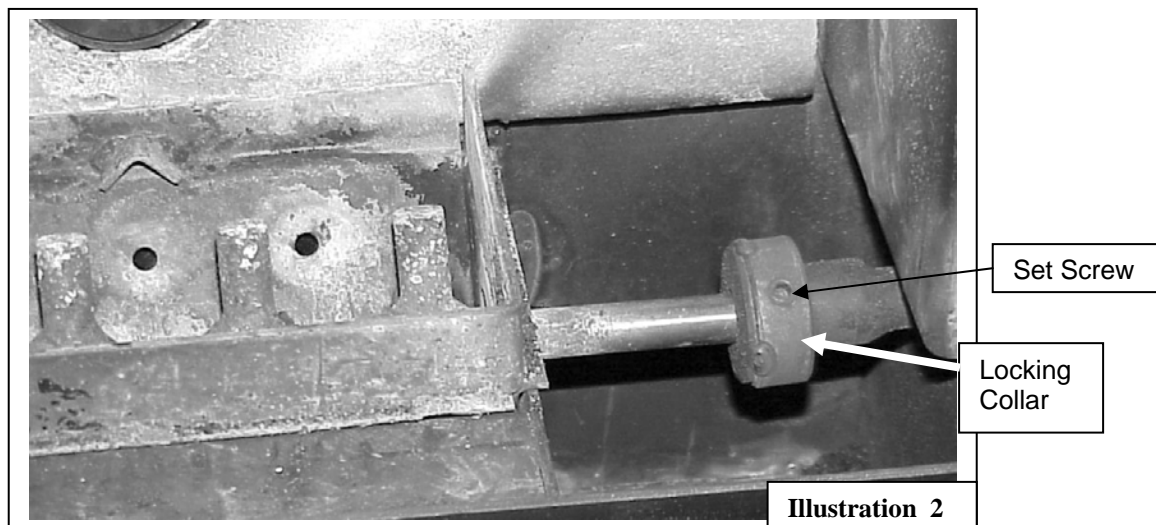

To remove the Stirrer for burning pellets

While the unit is **COLD** and the unit is off, press and hold the Air On Temp button until the Stirrer is at the “12:00” position; loosen the Allen head Set Screw (marked in **Illustration 2**). Slide the locking collar (also marked in **Illustration 2**) to the Burnpot. Lifting the Burnpot and Stirrer at the same time, remove the Stirrer from the Burnpot and replace Burnpot back into the unit.

NOTE: When replacing the Burnpot, notice there is a welded piece that is always set toward the *back* of the Firebox.

E-Codes

“E-Codes,” or Error Codes, are codes that will appear in the Heat Range and Blower Speed windows of the Control Board if your unit experiences problems. If you receive these codes, **wait until the unit is cooled completely down before trying to restart your unit.**

If the unit continues to display any E-Code(s), please contact Customer Service at (800) 245-6489 before further attempting to restart your unit.

E-2 = Fail to Start

NOTE: “E-0” indicates “No Error”

First Fire: When you push the “ON” button, the Control Board will automatically be set at both “Heat Range” and “Blower Speed” to setting “5”. Allow the stove to burn in this manner for *at least* three (3) hours. This will allow the unit to “cure out” as the paint and the oils from the manufacturing process burn off. We recommend you open doors and windows in your dwelling during this process.

Subsequent Cold Starts: In a cold start situation, the unit should be operated at a “5” setting until the room air blower begins to operate.

NOTE: Press the “ON” button only once on start-up. Pressing the “ON” button a second time during the start-up cycle will cause the start-up cycle to begin again.

IMPORTANT: If the unit fails to start properly, or does not properly complete the Shut-Down procedure, **open the closest outside door and a window to eliminate the home’s natural draft BEFORE opening the stove’s door or hopper lid.** This will allow any smoke to exit through the external air hook-up instead of spilling into the home.

SHUT-DOWN PROCEDURE

WARNING: NEVER SHUT DOWN THIS UNIT BY UNPLUGGING IT FROM THE POWER SOURCE.

Refer to the following instructions:

Press the “OFF” touch pad to put the stove in the “Shut-Down” mode. There will be an “S D” in the Heat Range and Blower Speed windows while the unit is shutting down to verify this. At this time the red light above the “OFF” pad will illuminate. When the “OFF” pad is touched the auger will instantly stop feeding fuel to the auger tube, but the room air blower, exhaust blower and bottom auger will continue to operate. When the internal temperature drops to 95 degrees the room air blower will cease to operate, and when the internal temperature drops to 90 degrees the exhaust blower will stop. The red light will then shut off and the entire stove will be shut down. The hotter the unit is operating, the longer it will take for the stove to complete the Shut-Down cycle.

Note: The unit will exit the Shut-Down cycle if you press any buttons during Shut-Down.

Note: If the room temperature stays above 70 degrees the stove will remain in the Shut Down mode for 60 minutes, regardless of the temperature reading at the heat sensor. If the stove stays on longer than 60 minutes the unit will automatically turn off.

NOTE: **If your unit overheats the auger will stop feeding and the unit will go into Shut-Down if it does not recover; if this happens you need to wait 45 minutes before trying to re-light the unit.**

DAILY OPERATION

Refueling the Unit

Always press the “OFF” touch pad before refueling. This stove has a approximately 80-lb. hopper, and should be refilled when the hopper level drops to three or four inches.

Note: The hopper lid will be warm; therefore, you should always use some type of hand protection. NEVER place your hand near the auger while the stove is operating.

Note: Always ensure that all corn and pellet matter is cleared from the hopper lid gasket before closing. Be sure to close and latch hopper **securely** before re-firing. Do not operate this unit with the hopper lid open or unsecured.

Power Outage

If the power to the unit is interrupted for approximately three minutes or less, the unit will resume operation when power is restored according to the following table:

Unit's State Before Power Loss	State When Power Returns
ON	Start-Up
Start-Up	Start-Up
Shut-Down	Shut-Down
OFF	OFF

If the power is interrupted for more than (approximately) three minutes, the unit will be “OFF” when power returns.

Important: Do NOT open the hopper lid or the door to the unit during power outage. Open the closest outside door and a window to eliminate the home's natural draft. Wait for power to be restored and then press the “ON” button to re-start the unit, if necessary.

NOTE: Remember:

- 1) It is **very** important for the unit to be vented properly (see instructions on Outside Air), as the natural draft is needed to clear the smoke from the stove.
- 2) Do not open the hopper lid (or the unit's door). This may cause fire to burn in the hopper.

Fuel Outage

If your unit runs out of fuel, let the unit go through the complete Shut-Down cycle and then follow the instructions for restarting the unit.

NOTE: DO NOT TRY TO RESTART THE UNIT HOT. If the unit runs without pellets or corn, after one hour the unit will shut down.

Combustion Blower Failure

If the Combustion (exhaust) Blower should fail on this unit, a Vacuum Shut-Down Switch will automatically stop the auger. This will cause your stove to stop feeding fuel to the firepot, and the unit will eventually stop completely. Check your power supply, including tripped breakers, etc. If the blower has failed, you will need to contact Customer Service at (800) 245-6489.

NOTE: It is **very** important for the unit to be vented properly (see instructions on Outside Air), as the natural draft is needed to clear the smoke from the stove.

ASH REMOVAL AND DISPOSAL

IMPORTANT: While the amount of ash generated by this unit is not excessive compared to log-burning woodstoves, keeping the unit clean and free of ash is essential for peak performance. Too much ash build-up hampers airflow and reduces the unit's efficiency, and can cause smoke-back.

Daily Ash Maintenance

Press the "OFF" touch pad and allow the stove to burn for five (5) minutes prior to opening the door. A long-handled screwdriver or long-handled putty knife can be used to scrape off any build-up or crust in the Burnpot area. This can then be pushed to the left or right into the ash storage area.

Ash Pan

NOTE: The ash pan must be latched when the unit is in operation. NEVER operate the unit with the ash pan out! This unit has an ash pan for more convenient and hassle-free cleaning; to open, simply pull the handles and rotate them down, then pull the ash pan forward. Note also that there are two access panels (one on each side) inside the unit in the bottom; to put ashes into the ash pan, remove the panels and push the ashes into the ash pan and then replace them, making sure that the area under these plates are clear before replacing them. As noted below, the unit should be off and cooled before any ash maintenance.

Semi-Weekly Ash Removal

Twice each week: Shut the unit down by pressing the "OFF" pad and allowing the unit to go through the complete Shut-Down cycle. Allow the unit to completely cool down and then remove the ashes with a scoop, as described in the Ash Pan section above. The ashes should be placed in a non-combustible container with an airtight lid and should always be placed on a non-combustible surface or on the ground until completely cooled and free of hot cinders. Once the ash is removed, the Burnpot should be given a thorough inspection. Remove and clean the Burnpot. Check for any build-up in the front of the burn area. Clean out all air holes, these air holes should be kept clean, as they supply combustion air under and around the fuel. The Burnpot assembly should also be thoroughly cleaned, including the Firebox.

IMPORTANT: Ash build-up can cause the unit to malfunction.

Monthly Ash Removal

Use a screwdriver or chisel and break any creosote build-up in the front of the unit, where the pellets are fed into the Burnpot from the Auger Tube. Moisture in the pellets and resulting build-up in this area can cause the auger to "squeal" or squeak. Also inspect your flue pipes, and remove ash buildup from the clean-out tee.

Annual Cleaning

The stove and the flue system should be given a complete cleaning at the end of the heating season. Remove the Burnpot, clean it thoroughly, and re-install it. In addition to the cleaning mentioned for semi-weekly and monthly, the Combustion (exhaust) Blower should be removed annually and the blower tube vacuumed of any ash build-up. When cleaning or replacing the blower a new gasket (Part # PU-CBG) should be added between the blower flange and the steel exhaust tube.

Soot and Fly ash: Formation and Need for Removal – The products of combustion will contain small particles of fly ash. The fly ash will collect in the exhaust venting system and restrict the flow of flue gases. Incomplete combustion, such as occurs during startup, shutdown, or incorrect operation of the room heater will lead to some soot formation which will collect in the exhaust venting system. The exhaust venting system should be inspected at least once every year to determine if cleaning is necessary.

MAINTENANCE

CAUTION: UNPLUG THE UNIT PRIOR TO ANY SERVICE WORK!

SEE EXPLODED DIAGRAM (ILLUSTRATION 6) FOR PARTS REFERENCE

Note: To do any service on this unit the rear access sheet metal panel must be removed. One (1) screw holds this panel to the rear of the stove.

Parts Orders: (800) 516-3636 www.englishstoves.com Questions: (800) 245-6489

Visit our web site for information that details and illustrates the following maintenance tasks.

Auger Motors

The Auger Motor and gearbox are one complete assembly, and can be removed by disconnecting the power leads and loosening the ($\frac{5}{16}$ " head) set bolt in front of the assembly. This bolt tightens down *on the flat side of the gear shaft* and locks the gear shaft and auger shaft together – once the bolt is loosened, the entire assembly will slide from the locking collar. There are two motor assemblies on the unit, and both rest on a shelf when not in operation. When replacing a motor, the assembly should always be placed to rest on this shelf prior to starting the unit.

Convection Blower

The Convection (room air) Blower (Part # **PU-4C447**) can be removed by disconnecting the power leads and removing the four mounting screws. Once this is done, the blower will slide out of the stove. This procedure can be reversed to install a new blower.

Combustion Blower

To clean or replace the Combustion (exhaust) Blower (Part # **PU-076002B**), the power leads from the blower and the corn vent pipe must be disconnected. Next, remove the screws that hold the blower to the steel exhaust tube and slide the blower from the stove. The blower impeller, blower tube and steel blower exhaust tube on the unit should be brushed and vacuumed. When cleaning or replacing the blower a new gasket (Part # **PU-CBG**) should be added between the blower flange and the steel exhaust tube.

Vacuum Switch

The vacuum switch (Part # **CU-VS**) is located above the Stirrer drive motor and shuts the feed auger off when the fuel door is left open or the combustion blower fails. If an operational error occurs in the unit, the switch will stop the feed auger. Situations which could cause this include power failure, Combustion Blower failure, improper flue installation, a blocked flue (from rodents, nests, etc.), or "dirty burning" from burning improper fuel (see "Important Information" at the beginning of the manual).

Gaskets

IMPORTANT: IMPROPER GASKET MAINTENANCE, INCLUDING FAILURE TO REPLACE GASKETS, CAN CAUSE AIR LEAKS RESULTING IN SMOKE-BACKS.

This unit comes with a $\frac{5}{8}$ " rope gasket around the door that should be replaced at least every two years. To replace the *door gasket* (Part # **AC-DGKNC**), the old gasket must first be removed entirely — prior to adding the new adhesive, you may have to scrape the old cement from the door channel. Once the cement and gasket have been added, the door should be closed and latched for twenty-four hours to allow the cement to harden.

If you are replacing the *window gasket* (Part # **AC-GGK**), the new gasket will already have adhesive on one side. Remove the paper on the adhesive side and place the gasket around the outside edge of the glass by forming a "U" with your fingers and placing the gasket around the glass. You should also replace the *Combustion Blower gasket* (Part # **PU-CBG**) whenever you remove or clean the Combustion Blower.

Finish

This new unit has been painted with High-Temperature Paint that should retain its original look for years. If the unit should get wet and rust spots appear, the spots can be sanded with plain steel wool and repainted. We recommend this paint, as others may not adhere to the surface or withstand the high temperatures.

Glass

This unit has a ceramic glass (Part # **AC-G10**, comes with gasket) in the viewing door. Surface scratches are acceptable, but if this glass becomes cracked in any area, the unit should be shut down and the window replaced with this high-temperature ceramic glass.

Auger Removal and Replacement

To remove the auger from the unit, you will first need to make sure that the unit has been shut down, unplugged and is cold.

IMPORTANT: Before removing the auger you will also need to remove any fuel that is in the hopper, including any sawdust or fines. Using a pair of regular pliers, simply grab the front part of the auger and pull forward.

To reinstall the auger, put the “notched” end of the auger into the tube and rotate clockwise until you feel the auger lock.



Control Board

The Control Board (Part # **CU-CB05**) is a digital read-out board. This board offers a wide variety of settings to operate the unit. This part can be removed from the unit by loosening the two outside screws and pulling the board back to the inside of the stove. The rear access panel should be removed prior to removing the control board. A 6-amp “quick-blow” fuse is used on this Control Board.

NOTE: The bottom three control buttons are preset at the factory and should *not* require any changes. See “Operating Instructions” and “Daily Operation” section of the manual for instructions on other Control Board settings.

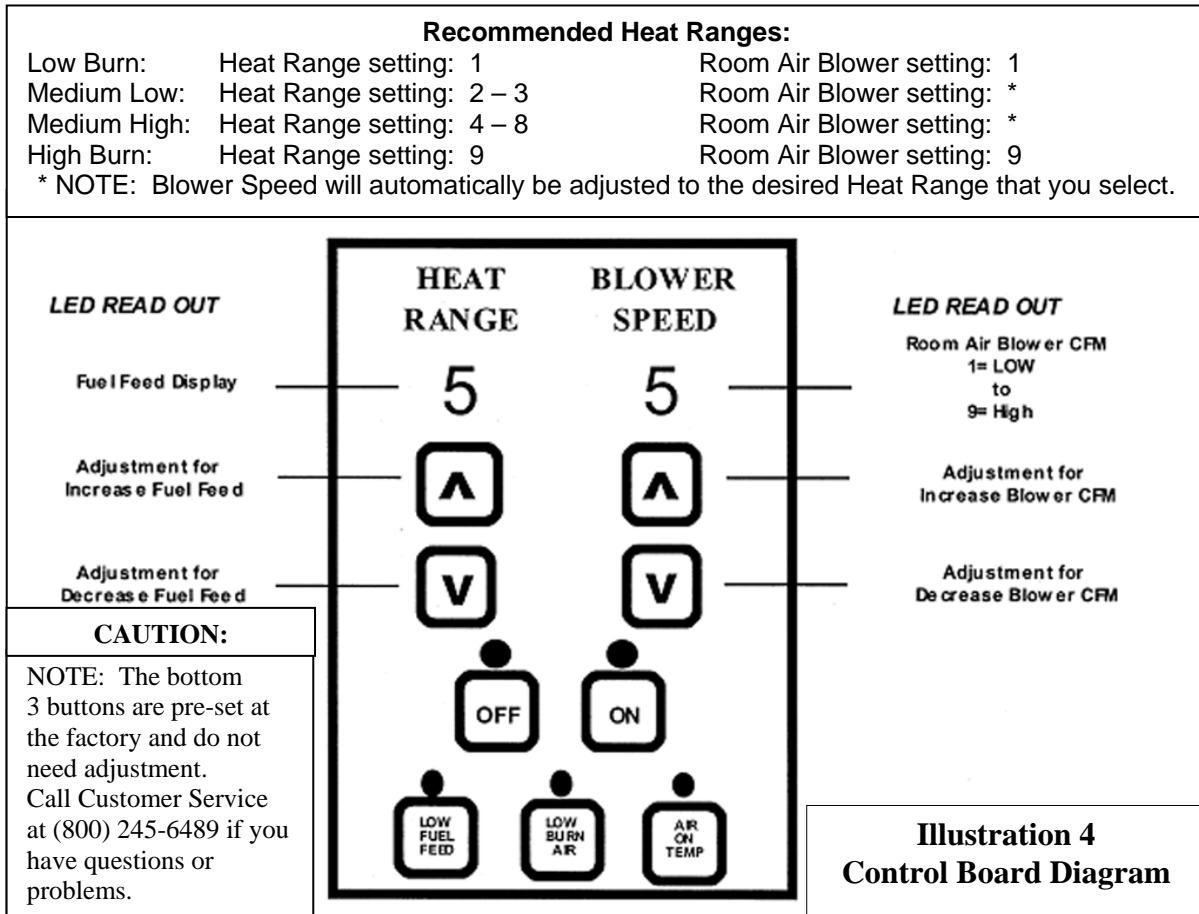

CAUTION: Moving Parts May Cause Injury.
Do NOT Operate with Panel(s) Off.

DANGER: Parts May Be Hot. Risk of Electric Shock.
Disconnect Power Before Servicing Unit.

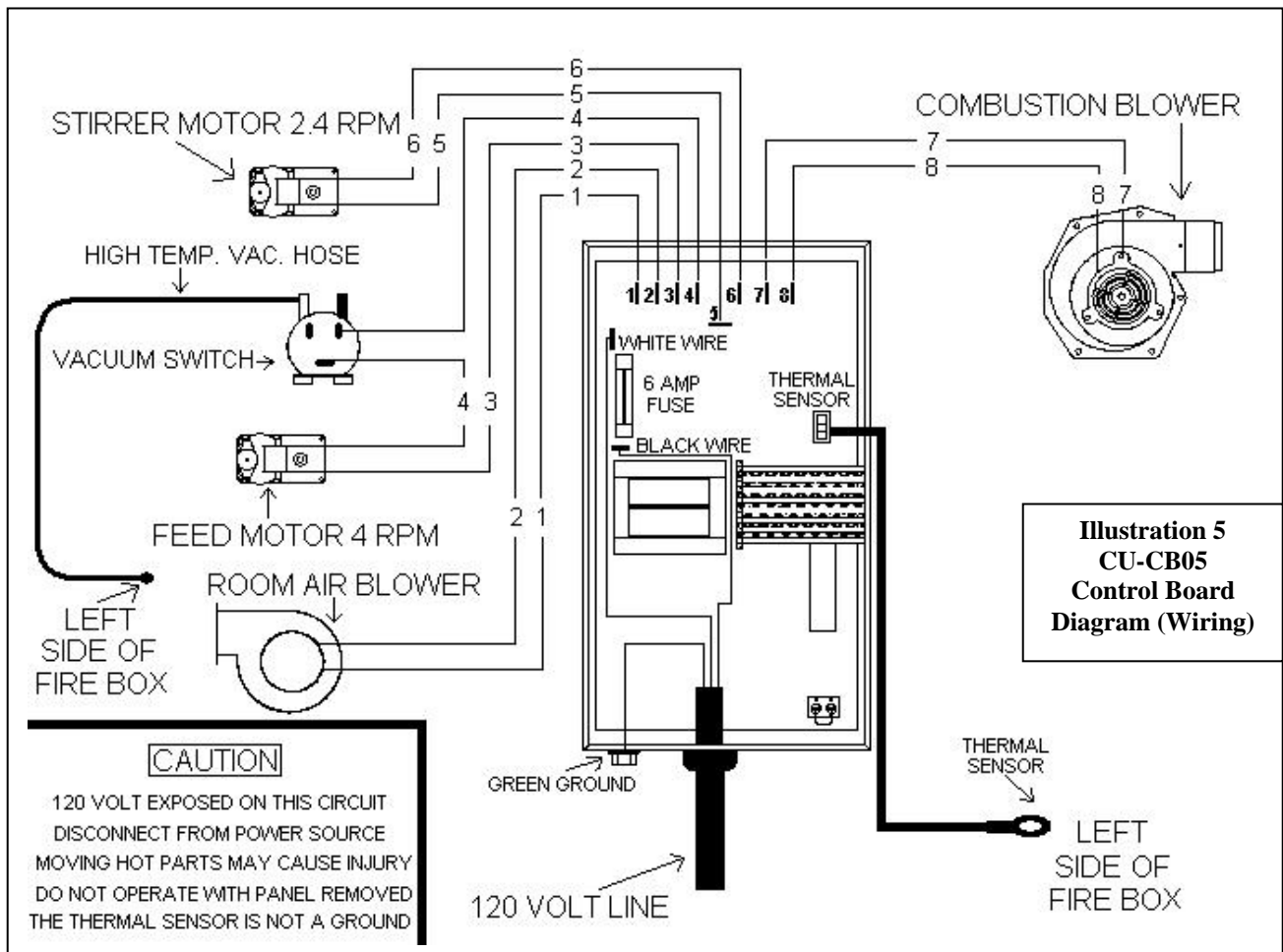

CIRCUIT BOARD FUNCTIONS

COMPONENT	OPERATION START	OPERATION END
Exhaust Blower	Starts Immediately	Will continue until shutdown. Shutdown will occur when the operating temperature is below 90 degrees.
Stirrer	Three minutes after starting, the Stirrer will begin to turn.	Will continue intermittently, as determined by the Heat Setting, until Shutdown
Auger	Three minutes after starting, the auger will begin to turn.	The auger will continue at the feed rate determined by the Heat Setting. NOTE: Safety switch, Hi Limit and Vacuum Sensor must be activated to continue proper operation.
Room Fan	Begins when 110 degrees is reached	Will continue to operate until the unit cools down to below 90 degrees. This may take from several minutes up to an hour.
Automatic Shutdown	If, after 15 minutes, the unit has not reached the preset operating temperature, the unit will begin to automatically shut down. This will be evidenced by the red light on the Control Board.	If the timer should expire before the preset operating temperature is achieved, resetting the timer is possible by switching the Control Board "OFF" and then back "ON."
Normal Operation	If, after 15 minutes, the preset operating temperature of 110 degrees is achieved, normal operation will continue.	Operation will continue until either the Control Board is turned "OFF," or the operating temperature falls to below 90 degrees. At this time, the unit will default to "Automatic Shutdown."

ACCESSORY ITEMS

The following accessories can be added to your unit at anytime after purchase; however, let the unit cool down before adding any accessories.

Thermostat

WALL: An external wall thermostat (such as our Part # **PU-DTSTAT**) can be used on our corn/pellet units as long as it is a low-voltage that works with millivolt systems. After unplugging the unit, locate the jumper wire (J-3) on the bottom of the control panel. The two screws should then be loosened and the jumper wire removed from the board. Next, the two thermostat lead wires should be slipped into these openings and the screws tightened; the jumper wire should be saved for future operation without a thermostat.

The unit will operate differently once the wall thermostat is connected – we recommend the Control Board be set at “9” on Heat Range and Blower Speed while using the thermostat. Refer to the section on “Start-up Procedure” for information on cold starts.

AC-117, AC-117BN Lip Trim

There are two pieces of J-Channel trim in this kit that snap onto the ash apron and top lips of the stove. Match the channel with the correct edge of the lip, then remove the protective covering from the trim and force the piece onto the edge. Although it should stay in place, stove cement can be used to secure it if necessary.

AC-118, AC-118BN Window Trim

Window trim can be attached by using the provided spring clip(s) and some high temperature silicone (optional). Insert the tee end of the spring clip into the channel on the edge of the trim – then, turn the clip and set the other end of the clip into the channel. The spring clip will hold well if it is placed on the top edge of the trim before placing the trim in the window of the stove. Place the top edge with the clip into the window opening, then push the bottom edge of the trim flush with the window. We also suggest that high temperature silicone be used on the corners, to ensure the trim will stay in place.

Accessories can be ordered from the factory at:

(Parts orders ONLY) -- **(800) 516-3636**, or on our web site: www.englishstoves.com .

Questions/Problems: Please call Customer Service at **(800) 245-6489**.

REPLACEMENT PARTS, ACCESSORIES AND OPTIONS

<u>ITEM</u>	<u>PART NUMBER</u>	<u>PART DESCRIPTION</u>
1	CA-13C	Door
2	AC-G10	Glass with Gasket
	AC-GGK	Glass Gasket Kit (not shown) (gasket only, no glass)
	AC-DGKNC	Door Gasket Kit (not shown)
3	CU-GS	Glass Supports
4	CU-CFB	Brick Fiber Board
5	CU-BP	Burnpot
6	CA-FS	Fuel Stirrer
7	CU-SC	Fuel Stirrer Collar
8	CA-DS	Drive Shaft
9	CU-MC	Mounting Collar
10	CU-AFC	Auger
11	CU-RCP	Right Side Cover Plate
12	CU-047042	2.4 RPM Auger Motor
13	CU-CB05	Control Board
14	CU-VS	Vacuum Switch
15	CU-AP	Ash Pan
16	CU-BR	Base & Riser
17	PU-103-50	Ash Pan Latch (2 per stove)
18	PU-CBG	Combustion Blower Gasket
19	PU-076002B	Combustion Blower
20	CU-LCP	Left Side Cover Plate
21	CA-AT	Auger Tube Assembly (with Part CU-ASB, 2 per stove)
22	CU-RGN	Auger Tube Gasket
23	CU-047044	4 RPM Auger Motor
24	PU-4C447	Convection Blower
25	CU-HFG	$\frac{5}{8}$ " Hopper Flange Gasket
26	CU-RAP	Rear Access Panel
27	CU-HOP-CDV	Hopper
28	PU-HLG	Hopper Lid Gasket
29	CU-HL-CDV	Hopper Lid
30	PU-62-40-151-3	Hopper Lid Latch
31	CU-FST	Fuel Stirrer Tube
32	CU-ASB	Auger Shaft Bushing
33	CA-AMP	Auger Mounting Plate
34	CA-AC	Auger Coupler

(See Item numbers on Exploded Diagram for part location)

OPTIONS:

PU-OAK	Outside Air Kit (Now included with unit!)
AC-33000	3" Corn Vent Kit (Through-the-Wall)
PU-DTSTAT	Wall Thermostat
AC-117	Brass Lip Trim (2 pc.)
AC-117BN	Brushed Nickel Lip Trim (2 pc.)
AC-118	Brass Window Trim
AC-118BN	Brushed Nickel Window Trim
CA-14	9" Cast Leg (need 4 to convert to leg model)

If you have any questions or problems contact the Customer Service Department:

Customer Service Department service@englanderstoves.com

P.O. Box 206

Parts Orders ONLY: 800-516-3636

Monroe, VA 24574

Questions: 800-245-6489

(Fax: 434-929-4810)

You may also order parts and options, view frequently asked questions and more, on our web site: www.englanderstoves.com

Corn Stove – Exploded View Diagram
(Illustration 6)

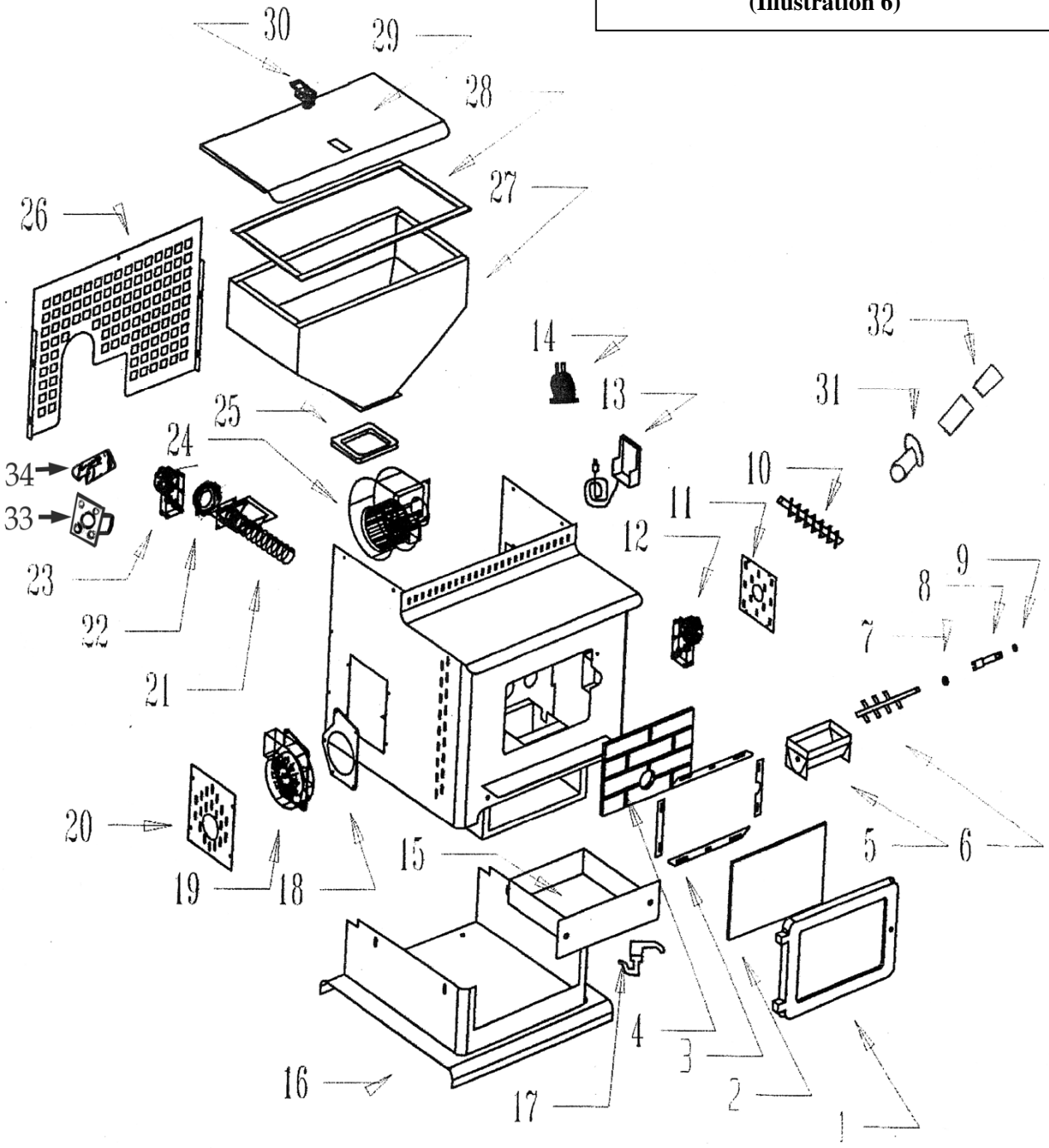

Adjusting your Hopper Lid Latch

The seals around the top of the pellet hopper are important to safe an efficient operation of the unit. The latch installed on these units is designed to pull the hopper lid tight against this seal. Over the course of operation as these seals “wear in” and compress, the tension of the latch should be tested periodically, and adjusted if necessary.

To adjust the lid latch, the following tools will be needed; two ½ inch wrenches, or a ½ inch wrench and a ½ inch socket.

In order to adjust the latch, first open the hopper lid and then lock the latch in its closed position. Then take the ½ inch wrench and loosen the nut closest to the latch. This nut is then adjusted closer to the lid itself to tighten the latch. After adjusting this nut to the desired location, hold this nut in place with the ½ inch wrench, the tighten down the holding nut on the end of the latch shaft with the ½ inch socket or second wrench to hold the latching assembly in place

After tightening the latch, test the latch for proper tension by locking the lid down and lifting each front corner of the lid. The lid should be firmly held down by the latch. Repeat the same procedure if the latch is still not tight enough.

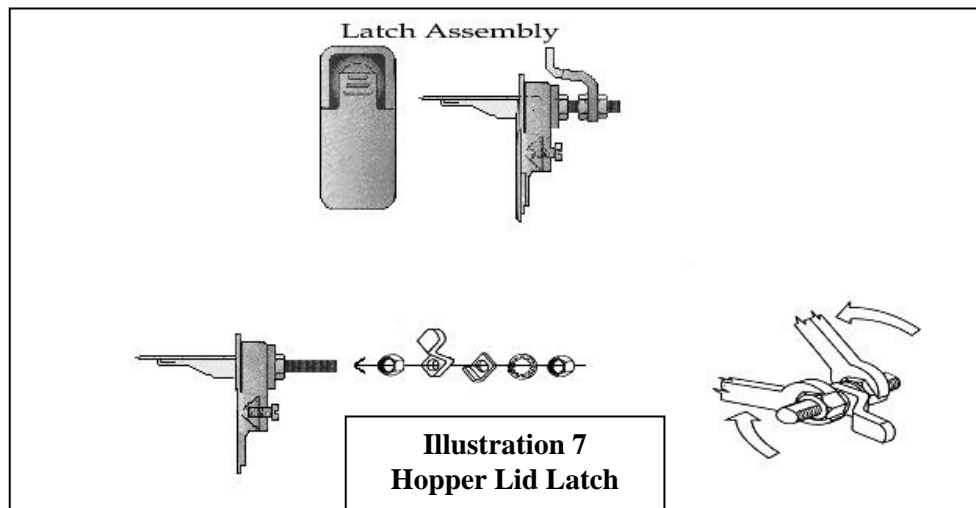

Important: Hopper Lid Latch must be checked periodically and kept tight so the top is sealed to prevent back-burn.

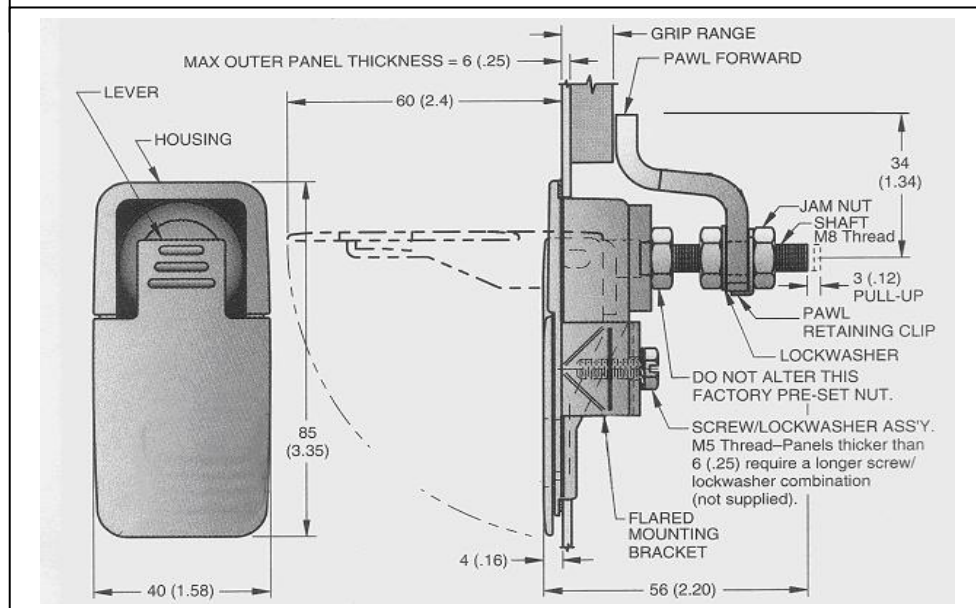

Latch Assembly

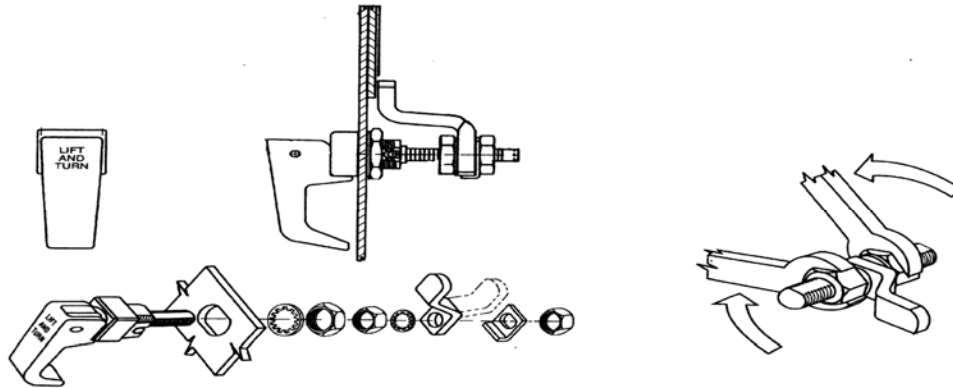

**Ash Pan Latch
Illustration 8**

Dimensions of your corn/pellet unit:

28"W x 33"H x 28"D 350 lbs.
(Approx. 18" height from floor to center of exhaust)



**LEG
ASSEMBLY**

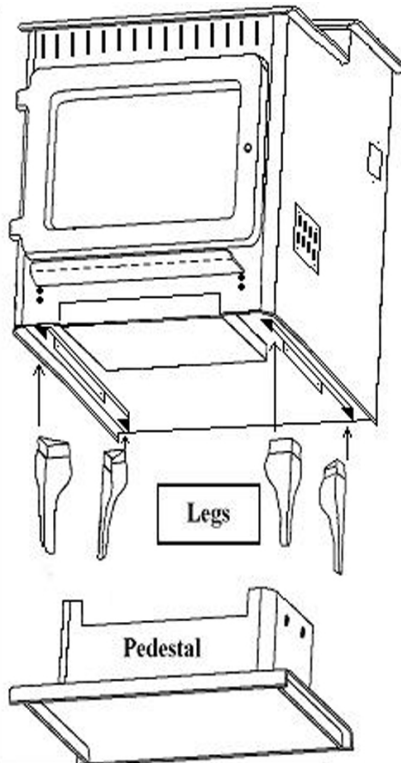

DIRECTIONS FOR INSTALLATION OF LEGS OR PEDESTAL:

(Stove must be cooled and all ashes cleaned out)

- * Remove bricks, disconnect flue, and turn stove on its back.
- * If you are replacing existing legs or pedestal, disconnect the existing legs or pedestal.

To install legs:

1. Each leg will fit into a pre-made slot on each corner of the bottom of the unit.
2. A 3/8" x 1-1/2" Carriage Bolt and matching nut is supplied with each leg. Fit a leg into a slot, and match the hole on the leg with the hole in the slot. Attach the legs one at a time, using the supplied bolts and nuts. Tighten securely.

To install pedestal:

1. Place spacers (provided) between the slots on the unit and the pedestal base (one spacer will fit on each side of the pedestal). Match the four holes in the pedestal (2 on each side) with the holes in the spacers and slots on the unit.
2. Use the four 3/8" x 1-1/2" Carriage Bolts and nuts (provided) to attach the pedestal to the base of the stove. Tighten securely.

- * After attaching the legs or pedestal, turn unit upright, reconnect flue and replace bricks according to manual.

Illustration 9

Base Options and Details

TROUBLE-SHOOTING GUIDE

WARNING: TO AVOID ELECTRICAL SHOCK ALWAYS *DISCONNECT* THE UNIT FROM THE POWER SOURCE BEFORE ATTEMPTING ANY REPAIR. IF THIS GUIDE DOES NOT CORRECT THE PROBLEM CALL YOUR LOCAL DEALER OR OUR CUSTOMER SERVICE AT 1-800-245-6489.

<u>Problem</u>	<u>Cause</u>	<u>Solution</u>
1. Auger not turning	<ol style="list-style-type: none"> 1. Loose set screw 2. Bad gear motor 3. Foreign matter in auger 4. Vacuum sensor (Top Auger) 5. Carbon buildup in feed auger tube 	<ol style="list-style-type: none"> 1. Tighten setscrew on collar 2. Replace auger motor 3. Remove pellets and object 4. Check exhaust blower 5. Remove carbon by scraping
2. Smoke smell or dust in house	<ol style="list-style-type: none"> 1. Improper exhaust connection 	<ol style="list-style-type: none"> 1. Check all connections for leaks especially the exhaust blower connection; Seal with silicone, hose clamp or aluminum tape
3. Room air blower not operating	<ol style="list-style-type: none"> 1. Loose sensor 2. High "ON" temperature 	<ol style="list-style-type: none"> 1. Tighten connection on sensor 2. Adjust temperature lower
4. Exhaust blower not operating	<ol style="list-style-type: none"> 1. Loose connection 2. Bad blower 3. Bad vacuum sensor 	<ol style="list-style-type: none"> 1. Check connection at c/board 2. Replace blower 3. Replace vacuum sensor
5. Lazy fire	<ol style="list-style-type: none"> 1. Control board settings 2. Bad exhaust blower 3. Excessive pellet moisture 4. Excessive ash 5. Low quality pellets 	<ol style="list-style-type: none"> 1. Review board settings 2. Replace blower 3. Keep pellets inside 4. Remove baffles; Clean unit 5. Use premium pellets
6. Blown fuse (6 AMP)	<ol style="list-style-type: none"> 1. Power surge 2. Exposed wire 3. Electric motor shorting or bound up 	<ol style="list-style-type: none"> 1. Replace fuse; use surge protector 2. Check for exposed or frayed wire and loose connections 3. Check motors and blowers for obstructions or lock-up
7. High pellet consumption	<ol style="list-style-type: none"> 1. Low quality pellets 2. Board out of adjustment 	<ol style="list-style-type: none"> 1. Use premium fuel 2. Check c/board settings
8. Squeaking noise	<ol style="list-style-type: none"> 1. Build up in tube 2. Improper auger alignment 3. Blower noise 	<ol style="list-style-type: none"> 1. Remove auger and clean 2. Re-align auger 3. Remove and oil blower
9. Pinging or rattling noise	<ol style="list-style-type: none"> 1. Foreign material 2. Loose set screw 	<ol style="list-style-type: none"> 1. Check blower for material 2. Check impeller blower screw
10. Unit shuts down in 20 to 30 minutes E2 error code	<ol style="list-style-type: none"> 1. Loose heat sensor 2. Control board settings 3. Failure to start 	<ol style="list-style-type: none"> 1. Check stove connection 2. Check settings; always start unit on "5" to "9" setting 3. Check igniter for buildup
11. Unit keeps shutting down ("E" codes on control board)	<ol style="list-style-type: none"> 1. Blocked flue (E-1) 2. Blower failure (E-3) 3. Improper installation* (E-1) 	<ol style="list-style-type: none"> 1. Check for flue blockage (nests, rodents, excess soot, etc.) 2. Check combustion blower wires, then call Cust. Svc. 3. Check for loose flue/pipe connections. Also be sure to have proper Outside Air hook-up.

**Improper installation may cause a back draft.*

***NOTE: Also check for loose or cracked vacuum hose on vacuum switches (see Parts Diagram).**

TROUBLE SHOOTING (Unit must be OFF, unplugged and cool before any maintenance)

PROBLEM	CAUSE: Too rich air/fuel mixture	
<p><i>Fire burns with a lazy, orange flame and/or fuel builds up in the firepot. Glass may become dirty.</i></p>	<p>Flue or intake is restricted.</p> <p>Make sure glass door is shut and sealed tightly. If not, adjust door handle or replace gasket if necessary.</p> <p>Verify ash removal plates are pushed completely in.</p> <p>Verify that exhaust fan is running and venting properly. If not, check connection and clean or replace.</p> <p>Moisture content above 15%. Allow fuel to dry or mix with some wood pellets.</p>	<p>Check inside stove and exhaust pipes for blockage. Tap inside walls of firebox, clean behind the lower access plates (located on the back inside wall, next to the firepot); clean firepot and firebox vent holes above firebrick panel.</p> <p>Feed rate is too High for fuel; reduce heat setting.</p> <p>Inadequate combustion air available; combustion air is mandatory (Our Part PU-OAK is acceptable).</p>
<p><i>Fire goes out or stove shuts down. Fuel may stop feeding.</i></p>	CAUSE: Firepot burns out of fuel	
	<p>Hopper empty; refill</p> <p>Auger jams. Remove auger and clean. Auger jams can be a problem if poor quality fuel is used, or if excessive fines (sawdust, corn cobs, husks, etc.) are present in hopper. Auger jams are evidenced when the auger turns, but no fuel is delivered.</p>	<p>Improper air mixture can cause the unit to burn fuel faster than the auger is feeding.</p> <p>Too many elbows in the venting restrict air flow.</p>
<p><i>Fire goes out or stove shuts down. Fuel may stop feeding.</i></p>	CAUSE: Auger stops turning	
	<p>Auger has come loose. Check to see if auger motor is turning and auger is not. NOTE: Auger is held to the auger motor by a coupler that is fastened to the auger motor with a setscrew. Simply slide the auger into the auger housing and rotate it until it fits into the coupler. If coupler is loose, remove the auger motor and tighten setscrew in the coupler.</p>	<p>Hi-limit sensor. Evident when the unit is extremely hot.</p> <p>Vacuum switch tripped. Caused by exhaust blower not running, or venting blocked. Check blower, clean or replace as necessary. Clean any blockage from venting.</p> <p>Auger motor not operating. Inspect connection and replace if necessary.</p>

**NOTE: Negative pressure in a home is a serious issue.
This unit must be installed with the Outside Air Kit (Part PU-OAK).**

Have this information on hand if you phone the factory or your dealer regarding this product.

Retain for your files:

Model Number _____

Date of Purchase _____

Date of Manufacture _____ Serial # _____

LIMITED 5 YEAR WARRANTY FROM THE DATE OF PURCHASE TO THE ORIGINAL OWNER

The manufacturer extends the following warranties:

Five Year Period:

1. Carbon steel and welded seams in the firebox are covered for 5 years against splitting.
2. The cast iron door and hinges are covered for 5 years against cracking.

One Year Period:

3. Component parts such as the hopper, auger Burnpot, baffle plate, auger shafts, auger bearings, and fasteners are covered for 1 year against cracking, breakage and welded seams from separating.
4. Electrical components, brick fiber board, accessory items, glass and the painted surface are covered for 1 year from the date of purchase.

Conditions and Exclusions:

Damage from over-firing will void your warranty.

This warranty does not apply if damage occurs because of an accident, improper handling, improper installation, improper operation, abuse, or unauthorized repair made or attempted to be made.

The manufacturer is not liable for indirect, incidental, or consequential damages in connection with the product including any cost or expense providing substitute equipment or service during periods of malfunction or nonuse.

All liability for any consequential damage for breach of any written or implied warranty is disclaimed and excluded. Some states do not allow the exclusion or limitations of incidental or consequential damages, so the above may not apply to you.

Procedure:

Purchaser must give notice of claim of defect within the warranty period and pay transportation to and from a service center designated by the factory. The dealer from which the unit was purchased or the factory, at our option, will perform the warranty service.

Other Rights:

This warranty gives you specific legal rights, and you may also have other rights, which may vary from state to state.

NOTE: THIS WARRANTY IS NULL AND VOID IF YOU DO NOT RETURN THE ATTACHED WARRANTY REGISTRATION WITH A COPY OF THE SALES RECEIPT WITHIN 30 DAYS FROM THE DATE OF PURCHASE.

WARRANTY IS NOT TRANSFERABLE

WARRANTY REGISTRATION for England's Stove Works

Purchased by (Name) _____

Address _____

City _____ State _____ Zip _____

Telephone _____

Email Address _____

DEALER INFORMATION

Purchased From (Dealer) _____

Address _____

City _____ State _____ Zip _____

UNIT INFORMATION

(Please be sure to refer to sticker on back of manual or box to complete this section)

Model Number _____ Purchase Date _____

Purchase Price _____

Serial Number _____ Mfg. Date _____

How did you first hear about our product? (please check one)

Word of Mouth Burn Trailer Demonstration Internet

Other: _____

Where did you receive information about our product? (please check one)

Rec'd. info. via phone Dealer (Name of dealer): _____

Internet Other: _____

IMPORTANT NOTICE

**THIS REGISTRATION INFORMATION MUST BE ON FILE FOR THIS WARRANTY TO BE VALID.
PLEASE MAIL THIS INFORMATION WITHIN THIRTY (30) DAYS FROM THE DATE OF PURCHASE.**

Mail To:

England's Stove Works, Inc.
Customer Service Department
P.O. Box 206
Monroe, VA 24574

Or, Fax To:

(434) 929-4810 – 24 hours a day

Or, now available – Go online to complete your Warranty Registration!

Visit www.englishstoves.com if you prefer to register online.