



21-PG100  
51-SHPG100  
51-TRPG100



Manufactured By:  
England's Stove Works, Inc.  
PO Box 206  
Monroe, VA 24574  
REV. 2/27/2013



**CAUTION**

**PLEASE READ THIS ENTIRE MANUAL BEFORE INSTALLATION AND OPERATION OF THIS PELLET FUEL-BURNING COOKING APPLIANCE. KEEP CHILDREN, FURNITURE, FIXTURES AND ALL COMBUSTIBLES AWAY FROM COOKING APPLIANCE. CONTACT LOCAL BUILDING OR FIRE OFFICIALS ABOUT RESTRICTIONS AND INSTALLATION INSPECTION REQUIREMENTS IN YOUR AREA.**

**FAILURE TO FOLLOW THESE INSTRUCTIONS CAN RESULT IN PROPERTY DAMAGE, BODILY INJURY OR EVEN DEATH. ENGLAND'S STOVE WORKS INC. WILL NOT BE HELD RESPONSIBLE FOR CARELESS AND DANGEROUS OPERATION OF THIS UNIT. ALL WARRANTIES ARE NULL AND VOID IF THE PRACTICES DESCRIBED IN THE OPERATOR'S MANUAL ARE NOT FOLLOWED.**

**A MAJOR CAUSE OF FIRES IS FAILURE TO MAINTAIN REQUIRED CLEARANCES (AIR SPACES) TO COMBUSTIBLE MATERIALS. IT IS OF UTMOST IMPORTANCE THAT THIS PRODUCT BE INSTALLED ONLY IN ACCORDANCE WITH THESE INSTRUCTIONS.**

**SAVE THESE INSTRUCTIONS.**

**IMPORTANT: IF YOU HAVE A PROBLEM WITH THIS UNIT, DO NOT RETURN IT TO THE DEALER. CONTACT TECHNICAL SUPPORT @ 1-800-245-6489.**

**Retain for your files**

Model Number \_\_\_\_\_

Date of Purchase \_\_\_\_\_

Date of Manufacture \_\_\_\_\_

Serial Number \_\_\_\_\_

\* This information can be found on the safety tag attached to the inside of the hopper lid. Have this information on hand if you phone the factory or your dealer regarding this product.\*

**DO NOT USE GASOLINE, GASOLINE TYPE LANTERN FUEL, KEROSENE, CHARCOAL LIGHTER FLUID, OR SIMILAR LIQUIDS TO START OR FRESHEN UP A FIRE IN THIS APPLIANCE. KEEP ALL SUCH LIQUIDS WELL AWAY FROM THE APPLIANCE WHEN IN USE.**

**CAUTION**

- Keep children away.
- Supervise children while appliance is in use.
- Alert children and adults to the hazards of high temperatures.
- Do NOT operate with protective barriers open or removed.
- Hot while in operation! Keep clothing, furniture, and other combustibles away. Contact may cause skin burns!
- This grill is intended for use as a food smoker, barbeque and grill. It is not intended for any use not specifically described in this manual. Misuse of this grill can result in serious property damage, bodily injury or even death.
- Use ONLY food-grade wood pellets with this unit.

# TABLE OF CONTENTS

## Introduction

- Introduction.....4

## Warning

- Warning.....5

## Assembly

- Assembly..... 6-7

## Getting Started

- Starting your grill.....8
- Manual start-up.....8
- Shut-down.....8

## Grill Operation

- Pre heat.....9
- Cook mode.....9
- Smoking.....9

## Grill Maintenance

- Painted steel surfaces.....10
- Burn pot and igniter.....10
- Drip pan.....10
- Grease bucket.....10
- Combustion chamber.....10
- Flame deflector.....11
- Grill interior.....11
- Steel grates.....11
- Cast iron grate.....11
- Door thermometer.....11
- Grill thermocouple.....11
- Disposal of ashes.....11
- Hopper and auger.....12
- Exhaust hood and chamber.....12
- Ash pan.....12

## Pellet Maintenance

- Pellet maintenance.....12

## Cooking and Food Safety Tips

- Cooking and food safety tips.....13

## Recommended Smoking Temperatures

- Smoking temperatures.....13

## Grilling Meat Temperatures

- Grilling meat temperatures.....14

## Component Replacement

- Cover panel.....15
- Combustion fan.....15
- Hopper lid safety switch.....15
- Auger motor/Auger..... 15-16
- Hopper lid latches.....16
- Door thermometer.....17
- Thermocouple.....17
- Exhaust hood and chamber.....17
- Burn pot.....18
- Igniter.....18
- Control board.....18

## Trouble Shooting

- Trouble shooting.....19

## Wiring Diagram

- Wiring diagram.....20

## Control Board Layout

- Control board layout.....21

## Exploded Diagram

- Exploded diagram.....22

## Optional Parts

- Optional parts.....22

## Replacement Parts

- Replacement parts..... 22-23

## Warranty

- Warranty details..... 24-25

## Serial Tag Sample

- Serial tag sample.....26

## Warranty Registration

- Warranty registration.....27

## INTRODUCTION

Thank you for purchasing this fine product from England's Stove Works!

England's Stove Works was started, and is still owned, by a family that believes strongly in a "Do It Yourself" spirit; that's one reason you found this product at your favorite "Do It Yourself" store.

We intentionally designed our pellet grills so that any homeowner can maintain their unit with basic tools. We're always more than happy to show you how to do the job as easily and as inexpensively as possible. While remaining simple, our grills are designed to perform extremely easily and efficiently, helping deliver a more enjoyable cooking experience.

Please look at our vast **Help Section** on our website ([www.pelletgrillsusa.com](http://www.pelletgrillsusa.com)) and call our Technical Support Department at (800) 245-6489 if you need any help with your unit. We are nearly always able to "walk you through" any repairs, problems or other questions that you may have.

Wishing you years of enjoyable, quality and safe cooking,

**EVERYONE AT ENGLAND'S STOVE WORKS!**

**Please Note: While information obtained from our web site and through our Technical Support line is always free of charge, there will be a service charge incurred with any "on-site" repairs or maintenance that we may arrange.**

# WARNING

**For outdoor use only. Do not use in any enclosed area. Do not install under a combustible ceiling or overhang.**

**Keep grill 12 inches (or more) on the front and sides, 18 inches (or more) in the rear from any combustible surface.**

**To prevent grease fires, be sure to clean your grill on a regular basis - this includes the flame deflector and ash pan. If a grease fire should occur, press the OFF button on the control board and leave the doors closed until the fire is out. DO NOT unplug the grill unless absolutely necessary. The combustion fan will continue to run for 5 minutes after the OFF button has been pressed.**

**Do not put anything flammable near the grill. This includes but is not limited to: gasoline, gas containers, gasoline-type lantern fuel, kerosene, propane tanks, and charcoal, charcoal lighter fluid, lighters, butane, etc.**

**Do not leave food containers, plates, etc. on or near the grill.**

**Always operate the grill with both doors closed.**

**Regularly check your burn pot for obstructions or any ash blockages that could prevent proper air flow to the fire. Refer to the *Maintenance Section* in this manual for cleaning procedures.**

**Do not use lava rocks, charcoal or any type of wood chips in your grill.**

**Your grill should be plugged into a GFCI (Ground-Fault Circuit Interrupt) outlet. DO NOT PLUG THIS UNIT UP TO AN EXTENSION CORD THAT IS NOT RATED FOR OUTDOOR USE, OR THAT IS LONGER THAN FIVE FEET (5').**

**It is recommended that you unplug the unit when not in use.**

**Surface temperatures will be extremely hot; we recommend the use of heat resistant gloves when operating this unit.**

**Do not attempt to move the grill while operating, or while the grill is still hot. Make sure the fire is out, and that the grill has cooled before moving or transporting the grill.**

**Use ONLY food-grade wood pellets in the operation of this grill (we recommend using flavored pellets from England's Stove Works, Inc.).**

**NEVER put your fingers near the auger, even if it is not rotating.**

## ASSEMBLY

When you receive your grill, a few parts will need to be assembled before you begin using your appliance. First, remove your manual, drip pan, the front and side shelves, and the legs. All of the hardware for attaching these will be included in the manual packet. You will need a ½" socket to attach the shelves.

The grease bucket will hang just to the bottom right of the grill, on the drain tube.



The longer shelf and heat shield must be attached to the four holes in the front of the grill. Before trying to install the legs/front shelf, lay the grill on its back. (This will allow for easier assembly.) First place the heat shield, with the holes lined up, on the front side of the grill. Then place the shelf on top of the heat shield with the holes in the shelf lined up with the shield. Then insert the four ½" bolts and washers in the four holes and tighten using a ½" wrench/socket.

\*Use the longer, 2 ¼" bolts for the front shelf.\*

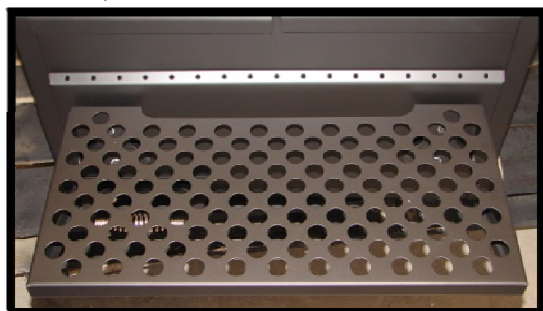

The shorter side shelf attaches to the four holes in the side of the grill. While holding up the shelf, insert and tighten the four washers and bolts, using a ½" socket. (In case of the need to replace this part, use the reverse of this procedure.)



## ASSEMBLY, CONTINUED

To install the legs, first place the back of the grill flat on the ground. Each leg attaches to four holes in the bottom of the grill. While holding each leg, insert and tighten the four washers and bolts, using a ½" socket. (In case of the need to replace this part, use the reverse of this procedure.)

If using the optional cabinet, the legs will not be needed.



Optional cabinet installation: The bolts that are intended for the legs will be used for the optional cabinet. Place the main body of the grill onto the cabinet and install the washers and bolts into the holes in the bottom of the grill, using a ½" socket. \*The cabinet will need to be assembled first; those instructions will be included with the cabinet.



**WARNING: NO  
COMBUSTIBLES SHOULD BE  
PLACED IN THIS OPTIONAL  
CABINET. DOING SO COULD  
CAUSE A FIRE OR  
EXPLOSION RESULTING IN  
INJURY OR DEATH.**

The grill's door thermometer will also need to be installed. Put the probe end of the thermometer in the hole in the right side door, and put the wing nut on and tighten by hand.

# GETTING STARTED

## Starting your Grill

Before cooking on your grill for the first time, we recommend that you allow the grill to “cure.” The process of curing the grill will allow any paint and oils from the manufacturing process to burn off. Add pellets to the hopper, then close and latch the lid. (The grill will not feed pellets with the hopper lid open.) Plug the power cord into a GFCI outlet. Press the ON button on the control board, and use the heat range arrow to select the desired cooking temperature. We recommend firing your grill to 450F and running the grill for at least 30 minutes with the front doors closed. After running the grill for at least 30 minutes, press the OFF button and allow the grill and the inside grates to cool. Once the grates have cooled, remove them, wash with hot soapy water and rinse them thoroughly. Wipe the grates down (or allow them to air dry) and place them back into the stove. You are now ready to cook on your grill.

**DAILY OPERATION:** During subsequent start ups after the first fire, it is recommended that you open both doors for at least five minutes during start up to allow the initial smoke to dissipate quicker. Once the grill has started, close both doors and then allow the grill to reach the temperature that was selected before cooking. Until the grill has ignited, you will see the lights under “Igniter” and “Auger” illuminating. Once the grill has ignited and the igniter has turned off, the red light will no longer illuminate under the “Igniter” display. The “Auger” light will illuminate green every time the auger is running during a cycle. As mentioned in the “Cooking and Food Safety Tips” section, use cooking oils on the cast grate to prevent food sticking, especially during the first few times you use your grill.

## Manual Start-up

In the event your igniter should fail, you may start your grill manually. Remove the cast iron grate and flame deflector (on the left, “direct” side). Check to be sure the burn pot is free and clear of any ash or debris. Place a small handful of pellets in the bottom of the burn pot. We recommend adding a small amount of pellet starter gel, then using a match, lighter or propane torch to start the fire. Once the fire has started to burn, use heat resistant gloves or oven mitts to put the flame deflector and cast iron grate back in place, close the front doors and press the ON button. Select the desired temperature and the grill will begin to feed pellets normally.

## Shut-Down

When you are finished using your grill you may press the OFF button on the control board. The board will then display “SHD” for shutdown. This will cause the auger to stop feeding pellets, and the combustion blower will continue to run for a period of 5 minutes. This will help the remaining fuel in the burn pot to extinguish and burn out. This process will also help keep the burn pot cleaner between uses. Open your doors to allow the heat to dissipate during shutdown. Make sure the grill is cool before covering.

# GRILL OPERATION

## Pre-Heat

“Pre-Heat” is the starting stage of cooking or smoking where the pellet fuel is fired, and the grill comes to the set temperature. It can occasionally take the grill up to 30-45 minutes to completely pre-heat. \*This time may be longer if you operate your grill during the colder months.

## Cook Mode

During Cook mode, the grill will maintain the temperature selected on the heat range. It is normal to see some fluctuation up and down of the temperature. NOTE: When adding, adjusting, or removing food, you may see a larger decrease in temperature, but once the doors are closed again the grill should return to set temperature.

\*The cast grate temperature (on the left, “direct” side) is 100-200 degrees hotter than the temperature on the right, “indirect” side, where the door thermometer is located. Please be aware that when grilling on the cast grate, the temperature will be hotter than the door thermometer indicates. This is a positive feature, since you will be able to achieve temperatures in excess of 600 degrees for cooking steak, etc.

## Smoking

Your grill has been designed to serve as an excellent smoker as well as a barbecue grill. Setting the control board heat range to lower temperatures is perfect for long (i.e. overnight) smoking. The temperature selected will depend on what foods are being smoked. Recommended temperatures for different meats are discussed later in this manual. Different varieties of food-grade flavored pellets may also be experimented with, to accommodate different tastes. Please note that (in general) the lower the temperature setting, the more smoke the grill will produce.

**CAUTION:** Always use a meat thermometer to ensure meats and poultry have been cooked to a safe internal temperature. **Serious health risks may occur when consuming undercooked meat.** We recommend using a good quality probe-type thermometer for the most accurate results.

**CAUTION:** We do not recommend using your grill as a smoker when outside temperatures are cold and windy. At smoking temperatures less than 225F, the chance of creosote forming from smoke condensation could be possible. Also, when operating during hot weather (90 degrees or above), it may be harder to maintain low grill temperatures (200 degrees or lower).

**Creosote – Formation and need for removal:** When wood pellets are burned slowly, they produce tar and other organic vapors that combine with expelled moisture to form creosote. The creosote vapors condense in the relatively cool oven flue and exhaust hood of a slow burning fire. As a result, creosote residue accumulates on the flue lining and exhaust hood. If ignited, this creosote makes an extremely hot fire. When grease or creosote has accumulated, they should be removed to reduce the risk of fire.

**\*There is risk of serious injury or death if the unit is over-fired. If operated and maintained properly, the unit should not over-fire. Any self modification to the unit could cause it to over-fire, and also voids any warranty.\***

# GRILL MAINTENANCE

**BEFORE PERFORMING ANY MAINTENANCE, BE SURE THE GRILL IS COMPLETELY COOLED. IT IS ALWAYS A SAFE PRACTICE TO USE HEAT RESISTANT GLOVES WHEN HANDLING SURFACES/OBJECTS THAT MAY STILL BE HOT.**

**\*SEE 'COMPONENT REPLACEMENT' AND 'EXPLODED DIAGRAM' PAGES TO REFERENCE THE LOCATION OF THESE PARTS**

## Painted Steel Surfaces

Although your grill is painted with very durable high temperature paint, always attempt to keep dirt and dust off the outside of the grill before cooking. Dust or dirt could be cooked into the metal, causing the paint to discolor. The surface can be cleaned with hot water and a mild detergent mix. To prolong the life of the paint, a grill cover is recommended. Before covering, make sure the grill has completely cooled - covering while still warm can cause condensation under the covering, leading to premature rusting.

## Burn Pot and Igniter

The burn pot air holes should be regularly checked for any blockages or buildup. The burn pot can be cleaned using a scraper, putty knife, or a wire brush to clean any buildup or blockages. The igniter should also be checked for buildup. **Continued burning with buildup on the igniter or in the burn pot could cause abnormal smoking, delayed firing of the grill, and possible injury (and could shorten the life of the igniter).**

## Drip pan

Lining the drip pan (located on the right, "indirect" side) with aluminum foil will greatly reduce the amount of cleaning of the drip pan. However, if cleaning is necessary, it can be done with hot, soapy water or a cleaning degreaser. This should be inspected at least twice a year to determine when grease and/or creosote buildup has occurred.

## Grease Bucket

Excess grease from cooking will travel down the drip pan and drain tube, and collect in a bucket on the bottom right side of the grill. This should be checked and dumped regularly to avoid spillage onto your deck (or other surface) that could cause stains, attract insects or cause unwanted smells, etc. Also check the drain tube for buildup and clean if necessary.

## Combustion Chamber

Due to the fact that the combustion fan forces air into the burn pot, the area around the fan stays relatively clean and does not require much maintenance. It is good practice to occasionally vacuum or brush this area out, to clean any ash or burn pot debris that may have fallen through.

# GRILL MAINTENANCE, CONTINUED

## Flame Deflector

The flame deflector is located on the left “direct” heating side, under the cast iron grate. It is recommended that you remove any food or grease buildup that may accumulate when cooking on the direct side. Also, regularly remove the flame deflector and clean it with a scraper or putty knife. This will greatly reduce the risk of grease flare ups during cooking. **Make sure the flame deflector is cool before cleaning.** It may be cleaned with hot, soapy water.

## Grill Interior

Although food-grade wood pellets burn very efficiently, they will still create a small amount of ash that will accumulate on the inside grill walls, doors, grates and in the ash pan storage area. Although it is not necessary to keep these areas spotless, occasional cleaning is recommended. This can be done with a scraper, putty knife, utility shop vac and some soft cloths.

## Steel Grates

Along with scraping the steel grates with a grill brush before each use, we also recommend periodically cleaning these grates with hot, soapy water. These grates are also dishwasher safe.

## Cast Iron Grate

The cast iron grate should be cleaned before each use with a grill brush. It may also be cleaned periodically with hot, soapy water.

## Door Thermometer

Over time, the thermometer probe may accumulate a small buildup of ash. To ensure the thermometer is accurately reading temperature, it is recommended that you clean the probe regularly with a wet cloth or paper towel.

## Grill Thermocouple

Over time, the thermocouple may also accumulate a small buildup of ash. To ensure the thermocouple is accurately reading temperature, it is recommended that you clean the tip off regularly, with a wet cloth or paper towel. If your actual temperature reading on the control board differs significantly from the door probe, that is an indication that the thermocouple needs to be cleaned off.

## Disposal of Ashes

Ashes should be placed in a metal container with a tight-fitting lid. The closed container of ashes should be placed on a non-combustible floor or on the ground, well away from all combustible materials, pending final disposal. When the ashes are disposed by burial in soil or otherwise locally dispersed, they should be retained in the closed container until all cinders have thoroughly cooled.

## GRILL MAINTENANCE, CONTINUED

### Hopper and Auger

Although food-grade wood pellets are typically cleaner than heating pellets, it is important to monitor the sawdust in the hopper and auger system. If you begin to notice a large accumulation of sawdust in the hopper and auger chamber, it is recommended that you remove the pellets and use a utility shop vac to vacuum out all of the loose sawdust. Keeping the hopper and auger free and clean of sawdust will ensure the grill is feeding pellets as accurately as possible. It is also recommended that you cover the grill when not in use, to prevent any water from reaching the pellets in the hopper. If the pellets get wet, they will expand and could possibly jam the auger.

### Exhaust hood/chamber

The exhaust hood and chamber area is where the exhaust exits the grill; it is located on the right side. It should be inspected at least twice a year to determine if creosote buildup has occurred. If there is a heavy buildup, it should be removed and cleaned.

### Ash pan

The ash pan is located on the bottom left of the grill. This should be cleaned before every use, to prevent the buildup of ashes and pellets that could potentially cause unwanted, uncontrolled fire.

*Now Serving...*

Pellet Grills!  
Proudly Made in U.S.A.  
[www.pelletgrillsusa.com](http://www.pelletgrillsusa.com)

## PELLET MAINTENANCE

To help ensure that your grill operates properly and without issue, it is important that you store pellets in a dry place, such as a basement or a garage (**as long as they aren't near chemicals**). Cooking pellets are about the thickness of a pencil eraser and vary from 1" to 1 ½". They start as sawdust that is filtered and compressed, then fed through a machine that cuts them to specified lengths. Then they are cooled, cleared of extra dust and bagged. No chemicals are added. Different woods can add extra flavor to your foods. **\*\*ONLY PUT THE AMOUNT OF PELLETS YOU INTEND TO USE FOR COOKING, BECAUSE OVER TIME PELLETS CAN ABSORB THE MOISTURE IN THE AIR AND SWELL, CAUSING AUGER JAMS OR FAILURE TO IGNITE. USE ONLY WOOD PELLET FUEL SPECIFIED BY THE MANUFACTURER. USE ONLY ENGLAND'S STOVE WORKS, INC. BRAND WOOD PELLETS. (8,500 BTU/LB. <1% ASH CONTENT) DO NOT USE PELLET FUEL LABELED AS HAVING ADDITIVES.\*\***

## COOKING AND FOOD SAFETY TIPS

Following are some basic cooking and safety tips. Be sure to refer to resources such as [foodsafety.gov](http://foodsafety.gov) for comprehensive safety information.

- Be sure your grill is clean, has enough pellets and preheated.
- Do your prep work ahead of time.
- Use cooking oils on the cast iron grate to prevent sticking.
- Remember that leaving the doors open for extended periods or overcrowding the grilling area may cause extended cooking times.
- Use long handled tongs for turning meats and a spatula for burgers. Using a fork could cause burns and could allow juices to escape the meat, causing dryness.
- Always thoroughly cook meats, and do not leave out of refrigeration for more than two hours.
- Wash hands and surfaces properly.
- Do not mix cooked and uncooked food.
- Marinate meats in the refrigerator.
- Defrost meats in the refrigerator.
- Do not save marinade.
- Use a meat thermometer to ensure proper internal temperatures.

## RECOMMENDED SMOKING TEMPERATURES

\*The times listed in the chart are only a guide, and may need to be adjusted based on the quantity and/or thickness of the meat. Check all meats' internal temperatures before serving.

MEAT	SET POINT °F	AVERAGE SMOKING TIME
Brisket	225	1 1/2 hours per pound
Beef Ribs	225	3 hours
Pork Butt	225	1 1/2 hours per pound
Whole Chicken	250	4 hours
Whole Turkey	240	6 1/2 hours
Spare Ribs	225-240	6 hours
Baby Back Ribs	225-240	5 hours
Smoked Fish	170 then 220	1-2 hours at 170 then 1-2 hours at 220

## GRILLING MEAT TEMPERATURES

CATEGORY	MEAT	INTERNAL TEMPERATURE °F	REST TIME
Ground Meat & Meat Mixtures	Beef, Pork, Veal, Lamb	160	None
	Turkey, Chicken	165	None
Fresh Beef, Veal, & Lamb	Steaks, roasts, chops	145	3 minutes
Poultry	Chicken & Turkey, whole	165	None
	Poultry breasts, roasts	165	None
	Poultry thighs, legs, wings	165	None
	Duck & Goose	165	None
	Stuffing (cooked alone or in bird)	165	None
Pork and Ham	Fresh pork	145	3 minutes
	Fresh ham (raw)	145	3 minutes
	Precooked ham (to reheat)	140	None
Seafood	Fin Fish	145 or cook until flesh is opaque and comes apart easily with a fork.	None
	Shrimp, lobster, and crabs	Cook until flesh is pearly and opaque.	None
	Clams, oysters, and mussels	Cook until shells open during cooking.	None
	Scallops	Cook until flesh is milky white or opaque and firm.	None

These are the US-government recommended minimum internal temperatures for listed meats, from [foodsafety.gov](http://foodsafety.gov). Remember that this is a listing of safe minimum internal temperatures only.

## COMPONENT REPLACEMENT

(WARNING: As with any maintenance concerning this unit, be sure the unit is “OFF” and has completed the Shut-Down cycle BEFORE beginning. Unplug the unit. Be aware that metal parts can remain HOT long after the fire has gone out and EVEN after the Shut-Down cycle is complete. Always use extreme caution when handling potentially hot parts, even if you think they should be cold.)

### Cover panel

To remove the cover panel: Using a 5/16” socket, loosen and remove the six screws on the cover panel, then slide the panel out and set aside. When finished with any trouble shooting or component replacement, reinstall the panel in the reverse of this method.

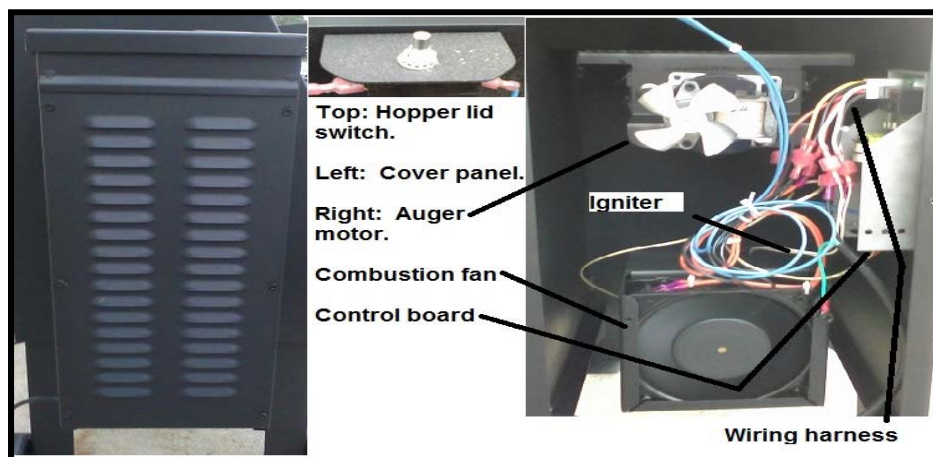

*Refer to this illustration for the procedures on this page*

### Combustion fan

Remove the cover panel. Unplug the wires from the fan. Lift the fan up and then remove. \*Because the ground wire is attached to the unit on the combustion chamber, it may be necessary to loosen this screw to remove the combustion fan. To install the new fan, use the reverse of this method, being sure to install the fan in the correct direction (with the fan blowing into the chamber).

### Hopper lid safety switch

Loosen the ½” nut, and then remove the nut and washer. Unplug the wires from the switch, taking note of where the wires are connected. To install the new switch, connect the wires to the new switch and then place the switch button into the hole and install the nut and washer, being careful not to over-tighten.

### Auger motor/Auger

\*Be sure to remove all the pellets from the hopper before trying to remove the auger or auger motor.\* Remove the cover panel. Unplug the auger motor wires from the wiring harness.  
(Continued next page.)

# COMPONENT REPLACEMENT, CONTINUED

## Auger motor/Auger continued

Loosen and remove the two 1/2" bolts holding the auger motor support shelf, then remove the assembly. You will need a 5/16" socket to remove the two screws that hold the auger motor to the support shelf (from the back side). Then remove the cotter pin that holds the auger to the auger motor. To remove the auger from the support shelf, simply slide it out. To reinstall this assembly, slide the auger in, connect it to the motor using the cotter pin, reinstall the two 5/16" screws through the shelf and motor, and slide the assembly (auger first) back in and reinstall the two 1/2" bolts.



## Hopper lid latches

To adjust the lid latch, the following tools will be needed: two, 1/2" wrenches (or a wrench and a socket). In order to adjust the latch, first open the hopper lid and then lock the latch in its closed position. Then take the 1/2" wrench and loosen the nut closest to the latch (see below). This nut is then adjusted closer to the lid itself to tighten the latch. After adjusting this nut to the desired location, hold this nut in place with the 1/2" wrench, then tighten down the holding nut on the end of the latch shaft with the 1/2" socket or second wrench, to hold the latching assembly in place. After tightening the latch, test the latch for proper tension by locking the lid down and lifting each front corner of the lid. The lid should be firmly held down by the latch. To replace the latch, remove the 5/16" screw from the bracket, using a socket or wrench. Remove the latch and replace with a new one, and reinstall the 5/16" screw and bracket.

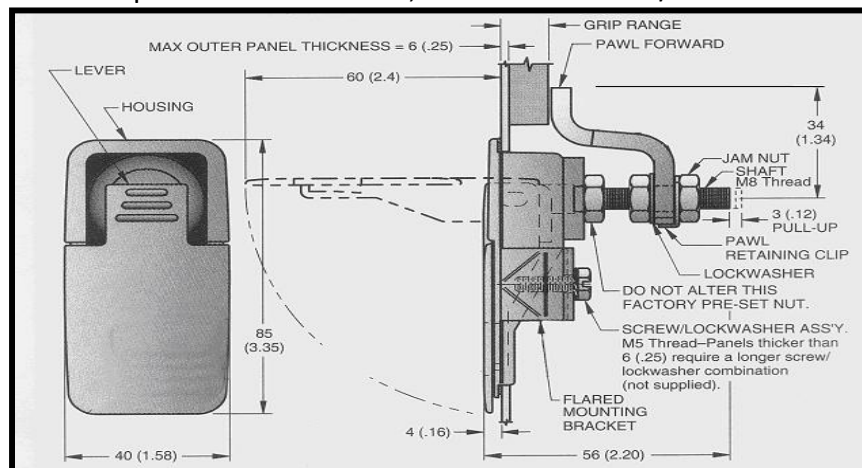

# COMPONENT REPLACEMENT, CONTINUED

## Door Thermometer

Open the right side door to the grill. Loosen and remove the wing nut on the thermometer. Then, pull the thermometer out of the door. To replace, put a new thermometer in the opening and reinstall the wing nut.

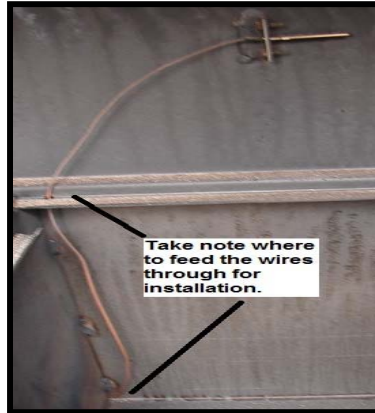
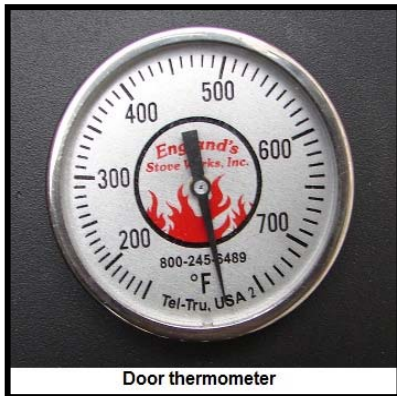

*Refer to this illustration for the procedures on this page*

## Thermocouple

Remove the cover panel and the control board (see instructions on Page 18). Then, using a small flat head jeweler's screwdriver, loosen the two screws that hold the thermocouple wires in place. (Note which color wires are on which side. The control board should also be marked with an "r" and a "y" directly next to where the wires are connected.) Next, open the front doors and locate the thermocouple along the right side of the rear wall of the grill. Using the 5/16" socket, loosen and remove the two screws that hold the thermocouple to the bracket. You can then pull the wires through and remove the thermocouple (take note as to where the wires feed through, as you will need to put the new wires back through the same way). To install the new thermocouple, feed the wires back through and reattach the thermocouple, using the two screws previously removed. Then reinstall the ends of the wires into the control board in the same position that they were previously. Reinstall the control board, using the same screws that were previously removed.

## Exhaust hood and chamber

The exhaust hood and chamber are located on the right side of the grill. To remove, use a 5/16" socket to remove the screws that secure the hood and chamber. Be sure to clean the parts and the side of the grill where the chamber was installed, using a specialty creosote remover and a scraper.

## COMPONENT REPLACEMENT, CONTINUED

### Burn pot

Remove the cover panel and unplug the igniter from the control board. Remove the cast iron grate inside the grill, and then remove the flame deflector. Pull up on the right side of the burn pot and remove it at an angle. Make sure to feed the ends of the wires (for the igniter) through the hole in the exhaust chamber when pulling out the burn pot.

### Igniter

Remove the cover panel and unplug the igniter from the wiring harness. Then, remove the combustion fan. Remove the cast iron grate from inside the fire chamber, and then remove the flame deflector. Remove the burn pot, making sure to feed the ends of the wires down through the hole drilled in the combustion chamber. Loosen the 1/8" allen set screw in the burn pot that secures the igniter. Pull the igniter out. To replace, insert the new igniter and tighten the set screw. Feed the wires back through the combustion chamber and up through the hole. Plug the wires back into the wiring harness and reinstall the combustion fan.

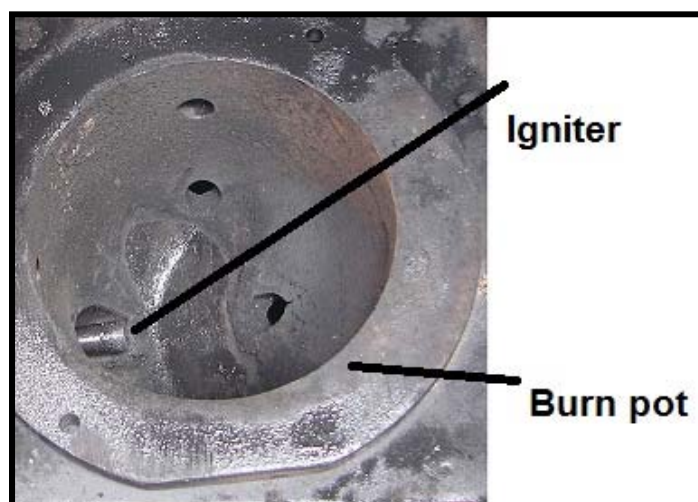

### Control Board

Remove the cover panel. Detach the wiring harness from the control board, by squeezing the arm on the clip and pulling slightly. Unplug the white and black wire from the harness for the power cord, then, using a 5/16" socket, remove the two screws that hold the control board in place. To reinstall, attach the two screws, then the white and black wires for the power cord and, lastly, reattach the clip with the wiring harness.

## TROUBLE SHOOTING

Problem	Cause	Solution
Grill will not turn on.	Grill is not properly plugged in.	Ensure that your grill is plugged into a <b>WORKING</b> GFCI outlet.
	A power surge has blown the fuse on the control board.	Replace the fuse with a 6 amp (125 volt) fuse.
Grill produces excess or discolored smoke.	Pellets may have absorbed excess moisture.	Clean the hopper and burn pot of any wet pellets and replace with dry ones.
	Burn pot is clogged with ash or carbon.	Check the burn pot for any ash or carbon deposits. Clean if needed.
Grill unable to reach or maintain stable temperature.	Grill not receiving sufficient fuel.	Check the hopper's fuel level, add pellets if needed.
	Grill not receiving sufficient air flow to burn pot.	Check the burn pot for any ash or carbon deposits. Clean if needed.
		Check to ensure the combustion fan is installed in the proper direction (should blow towards the fire), is plugged in and is still operating properly.
	Thermocouple problem.	If the door temperature is reading different from the control board then the thermocouple may need to be cleaned or there is a nick/kink in the wires.
	Igniter problem.	Check to ensure the igniter is plugged in and starts to glow after pressing the "on" button.
Frequent flame fluctuation.	Build up of creosote or carbon material.	Possible combustion failure/malfunction. Check combustion fan.
		Check the burn pot for any deposits or buildup.

Should you have an issue that is not addressed on this chart, or if you need assistance with any of the solutions, please contact our Technical Support line at 1-800-245-6489. If you need parts you can order them online at [www.pelletgrillsusa.com](http://www.pelletgrillsusa.com) or by contacting us at 1-800-245-6489.

## WIRING DIAGRAM

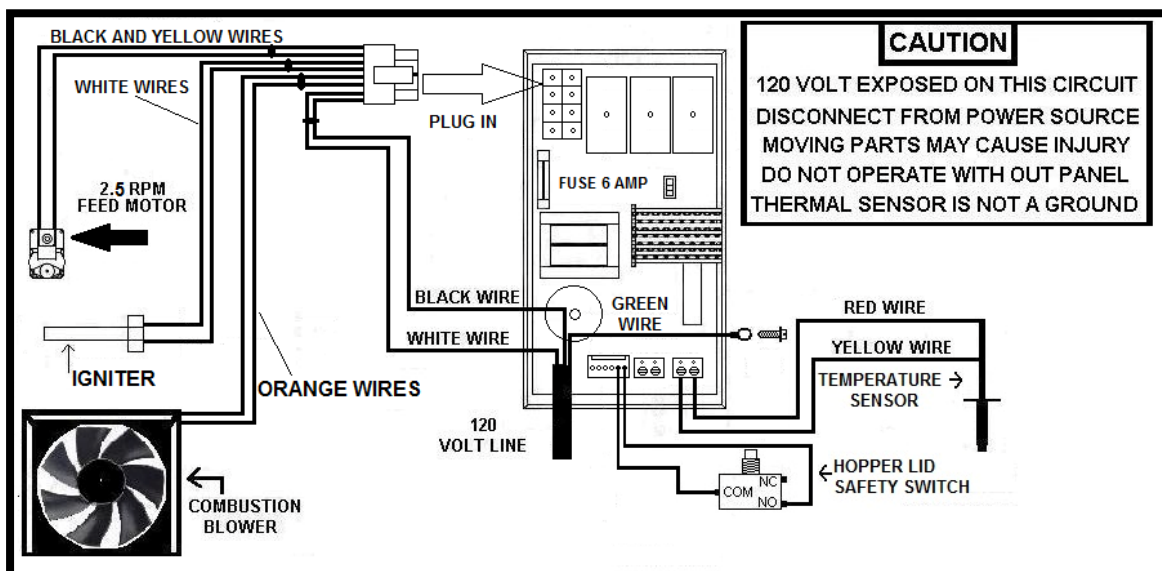

**\*A copy of this diagram is also in the area that encloses the motor and fan.\***

### **FOLLOW THESE GUIDELINES TO PREVENT THIS COLORLESS, ODORLESS GAS FROM POISONING YOU, YOUR FAMILY OR OTHERS:**

- **KNOW THE SYMPTOMS OF CARBON MONOXIDE POISONING: HEADACHE, DIZZINESS, WEAKNESS, NAUSEA, VOMITING, SLEEPINESS, AND CONFUSION. CARBON MONOXIDE REDUCES THE BLOOD'S ABILITY TO CARRY OXYGEN. LOW BLOOD OXYGEN LEVELS CAN RESULT IN LOSS OF CONSCIOUSNESS AND DEATH.**
- **SEE A DOCTOR IF YOU OR OTHERS DEVELOP COLD OR FLU-LIKE SYMPTOMS WHILE COOKING OR IN THE VICINITY OF THIS APPLIANCE. CARBON MONOXIDE POISONING, WHICH CAN EASILY BE MISTAKEN FOR A COLD OR FLU, IS OFTEN DETECTED TOO LATE.**
- **ALCOHOL CONSUMPTION AND DRUG USE INCREASE THE EFFECTS OF CARBON MONOXIDE POISONING. CARBON MONOXIDE IS ESPECIALLY TOXIC TO MOTHER AND CHILD DURING PREGNANCY, INFANTS, THE ELDERLY, SMOKERS, AND PEOPLE WITH BLOOD OR CIRCULATORY SYSTEM PROBLEMS, SUCH AS ANEMIA, OR HEART DISEASE.**

## CONTROL BOARD LAYOUT

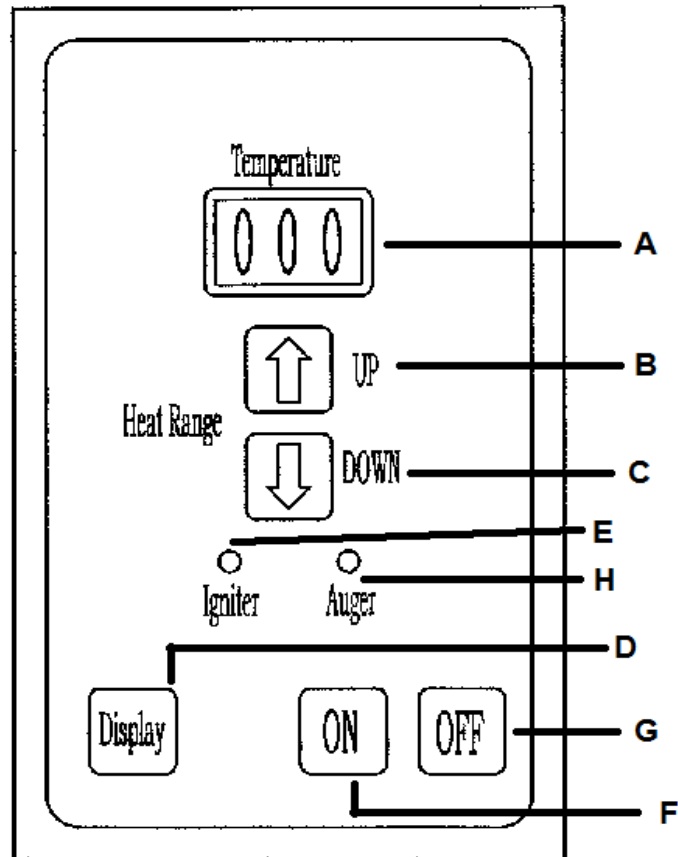

- A- Digital display**
- B- Increase temperature setting**
- C- Decrease temperature setting**
- D- Display options- Set temperature and actual temperature**
- E- Igniter on indicator**
- F- Grill on**
- G- Grill off**
- H- Auger on indicator**

# EXPLODED DIAGRAM

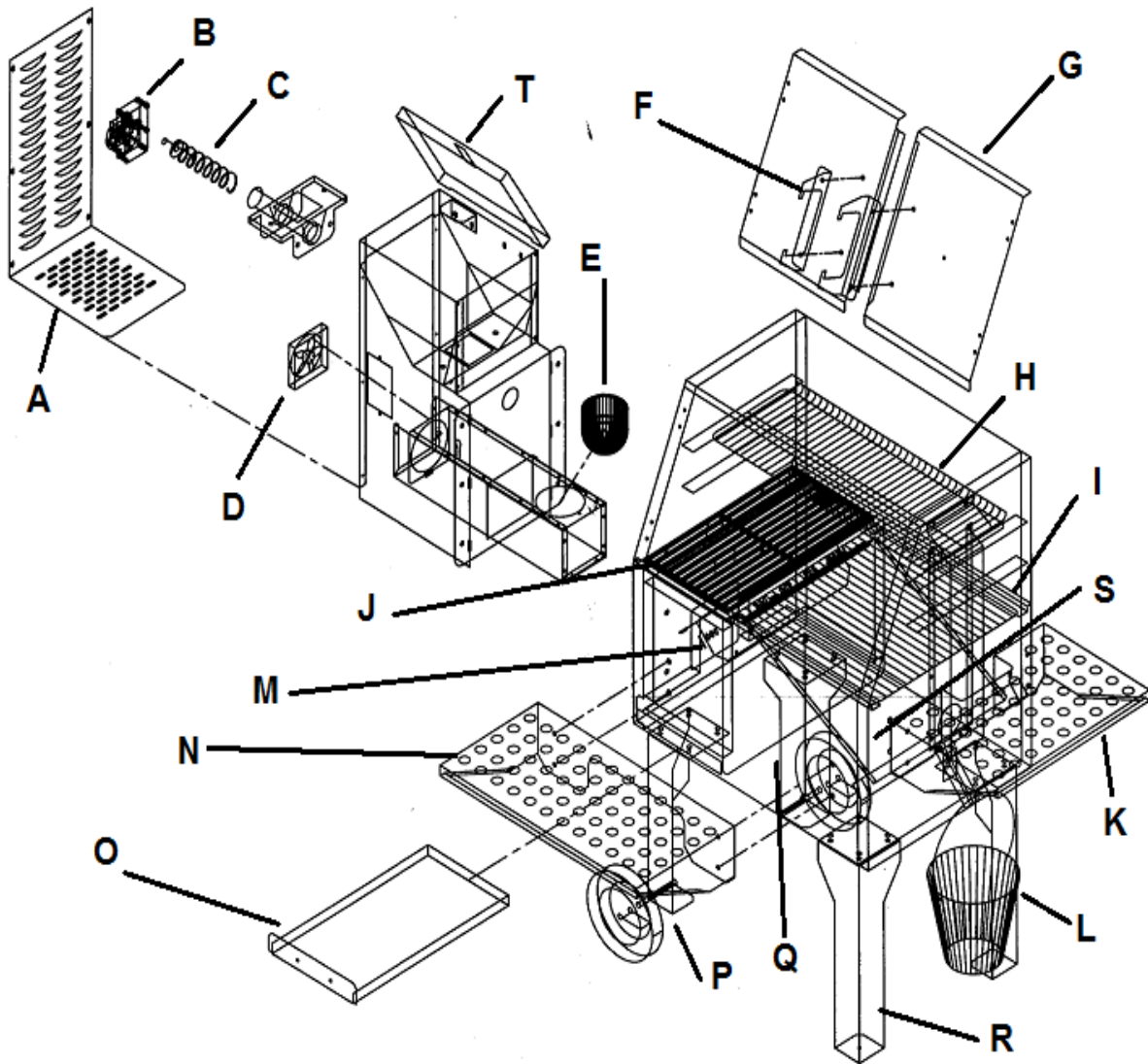

## OPTIONAL PARTS

\* DO NOT USE ACCESSORIES NOT SPECIFIED FOR USE WITH THIS APPLIANCE\*

PG-WB	Warming Box	not shown
PG-SC	Storage Cabinet	not shown
PG-RB	Recipe book	not shown

## REPLACEMENT PARTS

AC-CORD	Power cord	not shown
PG-BUSHING	Bushing for Auger	not shown
PG-FN	Fastener pack (shelf and handles)	not shown
PG-HPEL	Hickory Pellets (20 lbs)	not shown

## REPLACEMENT PARTS

PART NUMBER	DESCRIPTION	DIAGRAM REFERENCE LETTER
PG-TG	Metal Top grate	H
PG-CG	Cast Iron Grate	J
PG-SG	Metal Bottom grate	I
PG-BP	Burn pot	E
PU-CHA	Igniter	not shown
PG-WHLS	Hopper lid switch wiring harness	Not shown
PG-DB	Bucket	L
PG-THERM	Thermometer	not shown
PG-TC	Thermocouple	not shown
PG-CB12	Control Board	not shown
PG-SA	Steel Auger	C
PG-CBF	Combustion Fan	D
PG-MOTOR	Auger motor	B
PG-WH	Wiring Harness	not shown
AC-HLS	Hopper lid switch	not shown
PU-62-40-151-3	Hopper lid latch	not shown
PG-APH	Ash pan handle	not shown
PG-SHN	Spring handle (nickel) (2)	not shown
PG-SD	Steel Doors (2)	G
PG-BH	Door Hinges (4)	not shown
PG-AP	Ash Pan	O
PG-WHEEL8	Wheels	P
PG-HL	Hopper lid with attached hinge	T
PG-LEG	Legs (2)	R
PG-LGW	Legs (2) with wheel attachment	Q
PG-DP	Drip Pan	S
PG-FD	Flame deflector	M
PG-HMB	Handle mounting bracket	F
PG-AMSS	Auger motor support shelf	not shown
PG-CP	Cover panel	A
PG-SR	Side Rack	K
PG-FR	Front Rack	N
PG-DVD	Instructional DVD	not shown
AC-MBSP	Black Hi-Temp spray paint	not shown

## **LIMITED 1 YEAR WARRANTY**

**From the date of purchase to the original owner**

The manufacturer extends the following warranties:

### **One Year Period:**

1. Component parts such as the hopper, auger, burn-pot, auger shaft and fasteners are covered for one (1) year against cracking, breakage and welded seam separation.
2. Electrical components and accessory items are covered for one (1) year from the date of purchase.

### **Conditions and Exclusions**

1. Damage resulting from over-firing will void your warranty.
2. This warranty does not apply if damage occurs because of an accident, improper handling, improper installation, improper operation, abuse or unauthorized repair made or attempted to be made.
3. The manufacturer is not liable for indirect, incidental, or consequential damages in connection with the product including any cost or expense, providing substitute equipment or service during periods of malfunction or non-use.\*
4. The painted surface of the stove is not under warranty.
5. All liability for any consequential damage for breach of any written or implied warranty is disclaimed and excluded.

### **Procedure**

Purchaser must give notice of claim of defect within the warranty period and pay transportation to and from a service center designated by the manufacturer. The dealer from which the unit was purchased or the factory, at our option, will perform the warranty service.

## **Other Rights**

This warranty gives you specific legal rights; you may also have other rights, which may vary from state to state.

Some states do not allow the exclusion of limitations of incidental or consequential damages, so the above may not apply to you

Please Note: This warranty is null and void if the attached warranty registration AND a copy of the sales receipt is not returned within thirty (30) days from the date of purchase.

**Warranty is not transferable.**

## **IMPORTANT NOTICE**

The registration information **MUST** be on file for this warranty to be valid. Please mail this information within thirty (30) days from the original date of purchase.

Use any of these three easy ways to send your warranty information in!

### **Mailing Address**

England's Stove Works, Inc.  
Technical Support Department  
P.O. Box 206  
Monroe, Virginia 24574

### **Fax Number**

(434) 929-4810 – Twenty-four hours a day

### **Online Registration**

Visit our warranty registration website at:

<http://www.pelletgrillsusa.com>

**(Warranty Card is on the last page of this manual.)**

# SERIAL TAG SAMPLE



**Intertek**

Model 21-PG100 / 51-SHPG100 / 51-TRPG100  
 Wood Pellet BBQ Grill/Smoker  
 Tested to UL Subject 2728-2009; CSA 22.2 #3

Manufactured by:  
 England's Stove Works, Inc.  
 589 S. Five Forks Rd.  
 Monroe, VA 24572

Manufacture Date	
Serial Number	

**CAUTION**

IMPROPER USE CAN CAUSE UNCONTROLLED FIRE. TO REDUCE FIRE RISK:

- USE ONLY FOOD-GRADE WOOD PELLETS.
- OPERATE ONLY PER MANUFACTURER'S INSTRUCTIONS.
- NEVER USE GASOLINE OR LIGHTER FLUID.
- ALWAYS STORE WOOD PELLETS AWAY FROM HEAT-PRODUCING APPLIANCES AND OTHER FUEL CONTAINERS.

IF FIRE OCCURS:

- CALL FIRE DEPARTMENT.
- DO NOT TRY TO MOVE THE APPLIANCE, TRY TO SMOTHER FIRE, OR PUT WATER ON THE FIRE.
- KEEP THE APPLIANCE CLEAN – SEE INSTRUCTION MANUAL FOR CLEANING AND PROPER OPERATION.

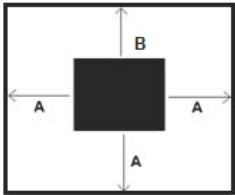

A: 12" CLEARANCE TO COMBUSTIBLES  
 Front and right side clearance is from the end of the shelves, the point furthest away from the grilling surface.

B: 18" CLEARANCE TO COMBUSTIBLES

THIS APPLIANCE IS INTENDED TO BURN ENGLAND'S STOVE WORKS, INC. BRAND HICKORY WOOD PELLET FUEL ONLY  
 8,500 BTU/LB. <1% ASH CONTENT

Keep doors shut during normal operation, unless adding/removing food or during warm-up.

ELECTRICAL RATING: 4.0 a, 115 V, 60 HZ. ROUTE THE POWER CORD SO THAT IT DOES NOT COME INTO CONTACT WITH ANY HOT SURFACES ON THE UNIT AND DOES NOT CROSS IN FRONT OF THE UNIT.

Fuel input rating: 4.0 lbs/hr

CAUTION – Moving Parts May Cause Injury. Do Not Operate Unit With Panels Removed.

CAUTION – Hot Parts. Do Not Operate Unit with Panels Removed.

DANGER – Risk of Electric Shock. Disconnect Power Before Servicing Unit.

CAUTION – Operate this unit only with the fuel hopper lid closed. Failure to do so may result in emission of products of combustion from the hopper under certain conditions. Do not overfill the hopper.

**CAUTION: NO COMBUSTIBLE ITEMS ARE TO BE PLACED ON/IN THE SHELVES/OPTIONAL CABINET. DOING SO COULD RESULT IN FIRE, EXPLOSION, SERIOUS INJURY OR EVEN DEATH.**

You may write your unit's manufacture date and serial number in the blank spaces on this sample tag for future reference. This sample tag also shows the safety information, such as UL/ULC testing standards, etc for your local officials, or anyone else who may need reference information. Your tag may be found under the hopper lid.

**WARRANTY REGISTRATION for England's Stove Works®**

Purchaser Information

I. Purchased By (Name) \_\_\_\_\_

II. Address \_\_\_\_\_

III. City \_\_\_\_\_ State \_\_\_\_\_ Zip Code \_\_\_\_\_

IV. Telephone Number \_\_\_\_\_

V. Email Address \_\_\_\_\_

Dealer Information

VI. Purchased From \_\_\_\_\_

VII. Address \_\_\_\_\_

VIII. City \_\_\_\_\_ State \_\_\_\_\_ Zip Code \_\_\_\_\_

Unit Information

IX. Model Number \_\_\_\_\_ Purchase Date \_\_\_\_\_

X. Purchase Price \_\_\_\_\_

XI. Serial Number \_\_\_\_\_ Mfg. Date \_\_\_\_\_

Purchase Questions

How did you first hear about our product? (Please check one)

Word of Mouth \_\_\_\_\_ Burn Trailer Demonstration \_\_\_\_\_ Internet \_\_\_\_\_

Other: \_\_\_\_\_

Where did you receive information about our product?

Via Telephone \_\_\_\_\_ Dealer (Name of dealer) \_\_\_\_\_ Internet \_\_\_\_\_

Other: \_\_\_\_\_