

**enerzone**

# Wood Stove Owner's Manual

## Part 2 of 2

### SOLUTION 1.4

(EB00061 model)

#### INSTALLATION AND OPERATION REQUIREMENTS

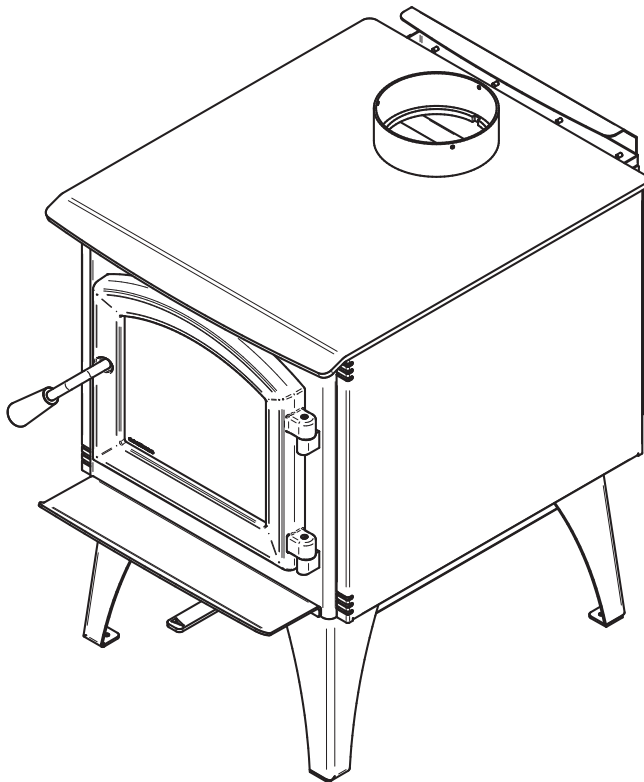

US Environmental Protection Agency  
phase II certified wood stove compliant  
with 2020 cord wood standard

**EPA**  
 $\leq 2.5$  g/h

Safety tested according to ULC S627,  
UL 1482 and UL 737 standards by an  
accredited laboratory.



ALCOVE



MOBILE  
HOME

ENGLISH

CONTACT LOCAL BUILDING OR FIRE OFFICIALS ABOUT RESTRICTIONS AND INSTALLATION INSPECTION REQUIREMENTS  
IN LOCAL AREA.

READ THIS ENTIRE MANUAL BEFORE INSTALLATION AND USE OF THIS WOOD STOVE. FAILURE TO FOLLOW THESE  
INSTRUCTIONS COULD RESULT IN PROPERTY DAMAGE, BODILY INJURY OR EVEN DEATH.

**READ AND KEEP THIS MANUAL FOR REFERENCE**

Dealer: \_\_\_\_\_

Installer: \_\_\_\_\_

Phone Number: \_\_\_\_\_

**Serial Number:** \_\_\_\_\_

### ONLINE WARRANTY REGISTRATION

If the unit requires repairs during the warranty period, proof of purchase must be provided. The purchase invoice must be kept. The date indicated on it establishes the warranty period. If it can not be provided, the warranty period will be determined by the date of manufacture of the product. It is also highly recommended to register the warranty online at

<https://www.enerzone-intl.com/en/warranty/warranty-registration/>

Registering the warranty will help to quickly find the information needed on the unit.



# TABLE OF CONTENTS

<b>1. CERTIFICATION PLATE .....</b>	<b>4</b>
<b>2. General Information .....</b>	<b>5</b>
2.1 Performances.....	5
2.2 Specifications.....	6
2.3 Dimensions .....	7
2.4 EPA Loading .....	9
<b>3. Clearances to Combustible Material.....</b>	<b>10</b>
3.1 Clearances.....	10
<b>4. Floor Protection .....</b>	<b>17</b>
<b>5. Reducing Wall and Ceiling Clearances Safely .....</b>	<b>18</b>
5.1 Shield Construction Rules .....	18
<b>6. Installation of options on your product.....</b>	<b>21</b>
6.1 Decorative Panels.....	21
6.2 Optional Fresh Air Intake Kit Installation .....	23
6.3 Optional Fire Screen Installation .....	24
6.4 Optional Blower And Thermodisc Installation.....	25
6.5 Air Tubes And Baffle Installation.....	26
6.6 Mobile Home Installation .....	28
<b>7. Maintenance/Parts Replacement.....</b>	<b>29</b>
7.1 Replacement.....	29
7.2 Gasket.....	30
7.3 Door .....	30
<b>8. Exploded Diagram and Parts List .....</b>	<b>33</b>
<b>ENERZONE LIMITED LIFETIME WARRANTY .....</b>	<b>36</b>

# 1. CERTIFICATION PLATE



Intertek  
May/Mai 2021  
Control number: 4002461

REFER TO INTERTEK'S DIRECTORY OF BUILDING PRODUCTS FOR DETAILED INFORMATION  
SE RÉFÉRER AU RÉPERTOIRE DES PRODUITS HOMOLOGUÉS D'INTERTEK POUR PLUS D'INFORMATION

STANDARDS / NORMES D'ESSAI:  
Certified to/Certifié selon ULC S627  
Certified to/Certifié selon UL 1482  
Certified to/Certifié selon UL 737  
Certified to/Certifié selon CSA B415.1-10  
Certified to/Certifié selon ASTM E3053-17  
Certified to/Certifié selon ASTM E2515-11 (R2017)

**LISTED SOLID FUEL BURNING APPLIANCE**  
**POÈLE À COMBUSTIBLE SOLIDE HOMOLOGUÉE**  
**MODEL / MODÈLE :**  
**SOLUTION 1.4**

Serial Number / No. de Série: **999967**

**Clearances to combustibles / Dégage­ments aux combustibles**

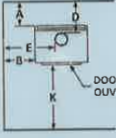

DOOR OPENING  
OUVERTURE DE PORTE

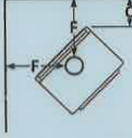

**MOBILE HOME  
MAISONS MOBILES**  
Double wall connector  
Tuyau à paroi double

A: 6 in./po. (152 mm) D: 9.25 in./po. (235 mm)  
B: 12 in./po. (305 mm) E: 18 in./po. (457 mm)  
C: 6 in./po. (152 mm) F: 12.875 in./po. (327 mm)

Back / Arrière

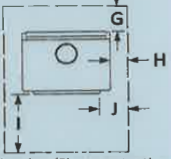

CANADA		U.S.A.	
Single wall connector Tuyau à paroi simple	Double wall connector Tuyau à paroi double	Single wall connector Tuyau à paroi simple	Double wall connector Tuyau à paroi double
A: 14 in./po. (356 mm)	A: 6 in./po. (152 mm)	A: 12 in./po. (305 mm)	A: 6 in./po. (152 mm)
B: 12 in./po. (305 mm)	B: 12 in./po. (305 mm)	B: 12 in./po. (305 mm)	B: 12 in./po. (305 mm)
C: 11 in./po. (279 mm)	C: 6 in./po. (152 mm)	C: 11 in./po. (279 mm)	C: 6 in./po. (152 mm)
D: 18 in./po. (457 mm)	D: 9.25 in./po. (235 mm)	D: 16 in./po. (406 mm)	D: 9.25 in./po. (235 mm)
E: 18 in./po. (457 mm)	E: 18 in./po. (457 mm)	E: 18 in./po. (457 mm)	E: 18 in./po. (457 mm)
F: 18 in./po. (457 mm)	F: 12.875 in./po. (327 mm)	F: 18 in./po. (457 mm)	F: 12.875 in./po. (327 mm)

**Protection de plancher/Floor protection**

CANADA	U.S.A.
G: 8 in./po. (203 mm)	I: 16 in./po. (406 mm)
H: 8 in./po. (203 mm)	J: 8 in./po. (203 mm)
I: 18 in./po. (457 mm)	K: 36 in./po. (914 mm)
K: 48 in./po. (1219 mm)	

\* See owner's manual for other clearances with lowered ceiling / voir manuel d'installation pour autres dégage­ments avec plafond abaissé

**PREVENT HOUSE FIRES**

- Install and use only in accordance with the manufacturer's Installation and operating Instructions.
- Contact local building or fire officials about restrictions and installation inspection in your area.
- Use listed 152 mm / 6 in. diameter single or double wall connectors with prefabricated chimneys approved UL 103 HT (US) and ULC S629 (CAN) suitable for solid fuels or lined masonry chimneys.
- See local building code and manufacturer's Instructions for precautions required for passing a chimney through a combustible wall or ceiling.
- This stove must be installed as a freestanding heater with the clearances listed in the manufacturer's Installation Instructions. It is strictly forbidden to install this stove in a factory-built fireplace.
- Do not pass connector through combustible wall or ceiling.
- Do not connect this unit to a chimney serving another appliance.
- For use with solid fuel only. Do not use other fuels.
- Operate only with door closed or door open with firescreen installed. Open door or remove firescreen to feed the stove only.
- Do not obstruct the space underneath the stove.
- Do not use grate or elevate fire. Build fire directly on hearth.
- Do not overfire. If heater or chimney connector glows, you are overfiring.
- Inspect and clear chimney frequently. Under certain condition of use, creosote buildup may occur rapidly.
- Replace glass with ceramic type only.
- Install unit on a non-combustible material extending as shown above on this label.
- Suitable for mobile-home installation.
- Combustion air openings shall not be obstructed.
- This wood heater needs periodic inspection and repair for proper operation. Consult the owner's manual for further information. It is against US federal regulations to operate this wood heater in a manner inconsistent with the operating instructions in the owner's manual.

**PRÉVENEZ LES INCENDIES**

- Installer et utiliser conformément au manuel d'utilisation du fabricant.
- Contactez les autorités de votre localité ayant juridiction concernant les restrictions et inspections d'installation.
- Utiliser des tuyaux d'évacuation à parois simple ou double homologués d'un diamètre de 6 po. (152 mm) avec une cheminée préfabriquée approuvée UL 103 HT (US) et ULC S629 (CAN) pour utilisation au bois ou une cheminée de maçonnerie gainée.
- Voir les codes locaux et le manuel d'installation du fabricant pour le passage de la cheminée à travers un mur ou un plafond combustible.
- Ce poêle doit être installé comme appareil de chauffage autonome avec les dégage­ments indiqués dans les Instructions d'installation du fabricant. Il est strictement défendu d'installer ce poêle dans un foyer préfabriqué.
- Ne pas traverser un plafond ou un mur combustible avec un tuyau d'évacuation.
- Ne pas raccorder cet appareil à une cheminée desservant un autre appareil.
- Pour l'usage avec du combustible solide seulement. Ne pas utiliser d'autres combustibles.
- Garder la porte fermée ou le pare-étincelle en place en tout temps. Ouvrir la porte ou retirer le pare-étincelle que lors du chargement.
- Ne rien entreposer sous l'appareil.
- Ne pas utiliser de grilles ou de chenets pour surélever le feu. Préparer le feu directement sur l'âtre.
- Ne pas surchauffer. Si l'appareil ou le tuyau rougit, il y a surchauffe.
- Inspecter et nettoyer la cheminée fréquemment. Sous certaines conditions, l'accumulation de crésote peut être rapide.
- Remplacer la vitre seulement avec un verre de céramique.
- Installer l'appareil sur une plaque non combustible tel qu'indiqué sur l'étiquette.
- Poêle approuvé pour maison mobile.
- Les entrées d'air servant à la combustion ne doivent pas être obstruées.
- Cet appareil de chauffage requiert des inspections et réparations périodiques. Consulter le manuel de l'utilisateur pour plus d'information. Opérer cet appareil de chauffage de façon inconsistante par rapport au manuel de l'utilisateur consiste une violation de la loi fédérale (USA).

Optional blower: (115V, 0.8A, 60Hz)      Option ventilateur: (115V, 0.8A, 60Hz)

U.S. ENVIRONMENTAL PROTECTION AGENCY Certified to comply with 2020 particulate emission standards using cordwood.  
AGENCE DE PROTECTION DE L'ENVIRONNEMENT DES É.-U. Conforme aux normes d'émission de particules de 2020 avec bûche de bois.

**Weighted average emission rate / Moyenne pondérée des émissions : 1.8 g/h**  
Tested and certified in compliance with CFR 40 part 60, subpart AAA, section 60.534(a)(1)(ii)

**WARNING:** This product can expose you to carbon monoxide, which is known to the State of California to cause cancer, birth defects or other reproductive harm.  
(For more information go to [www.p65warnings.ca.gov](http://www.p65warnings.ca.gov))



**CAUTION**

- HOT WHILE IN OPERATION.
- DO NOT TOUCH. KEEP CHILDREN, CLOTHING AND FURNITURE AWAY.
- CONTACT MAY CAUSE SKIN BURNS. SEE NAME-PLATE AND INSTRUCTIONS.

**ATTENTION**

- CHAUD EN FONCTIONNEMENT.
- NE PAS TOUCHER. GARDER LES ENFANTS, LES VÊTEMENTS ET LES MEUBLES ÉLOIGNÉS.
- UN CONTACT AVEC LA PEAU PEUT OCCASIONNER DES BRÛLURES. VOIR LES INSTRUCTIONS.

27868  
Made in St-Augustin-de-Desmaures (Qc), Canada  
16/06/2022 (# test)



Fabricant de poêles international  
Stove Builder International

Fabriqué à St-Augustin-de-Desmaures (Qc), Canada  
16/06/2022 (# test)

## 2. General Information

### 2.1 Performances

Values are as measured per test method, except for the recommended heating area, firebox volume, maximum burn time and maximum heat output.

Model	Solution 1.4 (EB00061)	
Type of combustion	Non-catalytic	
Fuel Type	Dry Cordwood	
Recommended heating area (sq. ft.) <sup>1</sup>	250 to 1,200 ft <sup>2</sup> (23 to 111 m <sup>2</sup> )	
Overall firebox volume <sup>2</sup>	1.8 ft <sup>3</sup> (0.0510 m <sup>3</sup> )	
Loading volume EPA	1.55 ft <sup>3</sup> (0.0439 m <sup>3</sup> )	
Maximum burn time <sup>1</sup>	5 hours	
Maximum heat output (dry cordwood) <sup>3</sup>	45,000 BTU/h (13.2 kW)	
Overall heat output rate (min. to max.) <sup>2 4</sup>	12,124 BTU/h to 26,700 BTU/h (3.55 kW to 7.83 kW)	
Average overall efficiency <sup>3</sup> (Dry cordwood)	74 % (HHV) <sup>5</sup>	79 % (LVH) <sup>6</sup>
Optimum efficiency <sup>7</sup>	80 %	
Optimum overall efficiency <sup>8</sup>	79 %	
Average particulate emissions rate <sup>9</sup>	1.8 g/h (EPA / CSA B415.1-10) <sup>10</sup>	
Average CO <sup>11</sup>	74 g/h	

<sup>1</sup> Recommended heating area and maximum burn time may vary subject to location in home, chimney draft, heat loss factors, climate, fuel type and other variables. The recommended heated area for a given appliance is defined by the manufacturer as its capacity to maintain a minimum acceptable temperature in the designated area in case of a power failure.

<sup>2</sup> The overall firebox calculation is an approximation and is not intended to be used for loading. This volume includes a buffer zone to allow an easier fuel insertion, prevent ash spillage and allow the air wash to work properly.

<sup>3</sup> The maximum heat output (dry cordwood) is based on a loading density varying between 15 lb/ft<sup>3</sup> and 20 lb/ft<sup>3</sup>. Other performances are based on a fuel load prescribed by the standard. The specified loading density varies between 7 lb/ft<sup>3</sup> and 12 lb/ft<sup>3</sup>. The moisture content is between 19% and 25%.

<sup>4</sup> As measured per CSA B415.1-10 stack loss method.

<sup>5</sup> Higher Heating Value of the fuel.

<sup>6</sup> Lower Heating Value of the fuel.

<sup>7</sup> Optimum overall efficiency at a specific burn rate (LHV).

<sup>8</sup> The optimum heat transfer efficiency is for the low burn rate and represents the appliance's ability to convert the energy contained in the wood logs into energy transferred to the room in the form of heat and does not take into account the chemical losses during combustion.

<sup>9</sup> This appliance is officially tested and certified by an independent agency.

<sup>10</sup> Tested and certified in compliance with CFR 40 part 60, subpart AAA, section 60.534(a)(1)(ii) and ASTM E3053-17 based on the ALT-125 sent by EPA on February 28<sup>th</sup>, 2018.

<sup>11</sup> Carbon monoxide.

## 2.2 Specifications

Recommended log length	16 in (406 mm) north-south
Maximum log length <sup>12</sup>	17 in (432 mm) north-south
Flue outlet diameter	6 in (150 mm)
Recommended connector pipe diameter	6 in (150 mm)
Type of chimney	ULC-S629, UL 103 HT (2100 °F)
Minimum chimney height	12 feet
Baffle material	C-Cast
Approved for alcove installation	Yes
Approved for mobile home installation <sup>13</sup>	Yes
Type of door	Simple, glazed, with cast iron frame
Type of glass	Ceramic glass
Blower	Optional (up to 100 CFM)
Particulate emission standard <sup>14</sup>	EPA / CSA B415.1-10
USA standard (Safety)	UL 1482, UL 737
Canada standard (Safety)	ULC-S627

<sup>12</sup> North-south: ends of the logs visible, East-west: sides of the logs visible.

<sup>13</sup> Mobile homes (Canada) or manufactured homes (USA): The US Department of Housing and Urban Development describes “manufactured homes” better known as “mobile homes” as follows; buildings built on fixed wheels and those transported on temporary wheels/axles and set on a permanent foundation. In Canada, a mobile home is a dwelling for which the manufacture and assembly of each component is completed or substantially completed prior to being moved to a site for installation on a foundation and connection to service facilities and which conforms to the CAN/CSA-Z240 MH standard.

<sup>14</sup> Tested and certified in compliance with CFR 40 part 60, subpart AAA, section 60.534(a)(1)(ii) and draft ASTM WK47329-14. Based on ALT-125 sent by EPA on February 28th, 2018.

## 2.3 Dimensions

### 2.3.1 Stove Dimensions

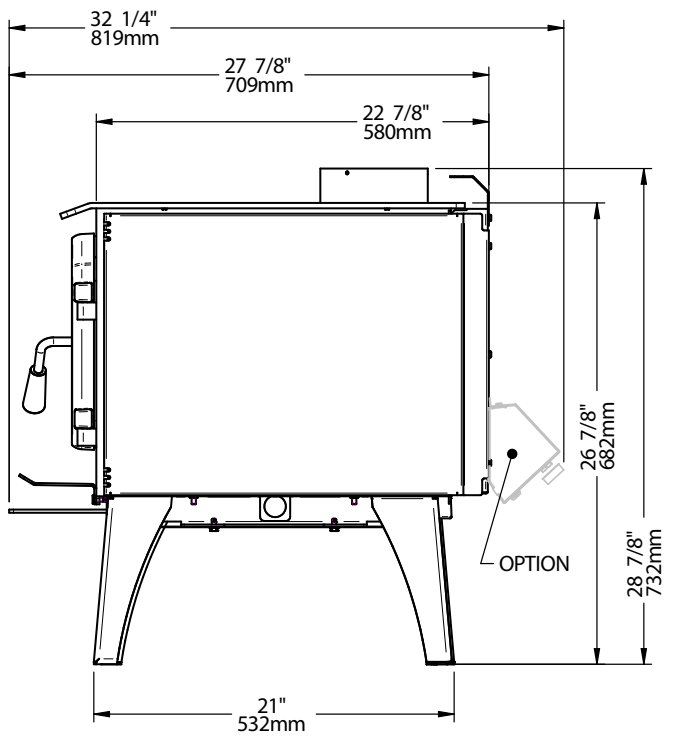
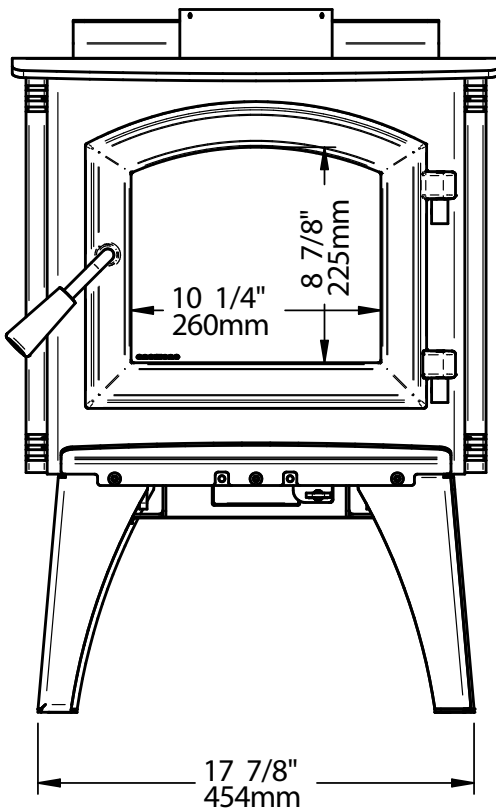
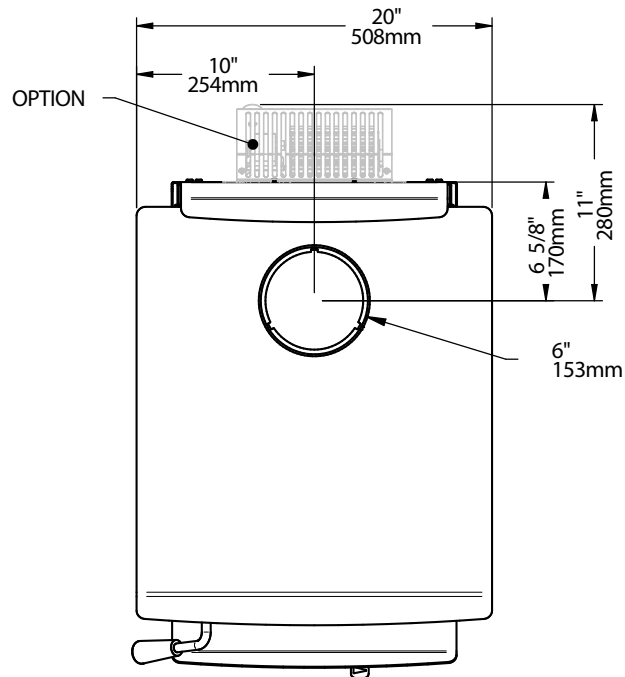

ENGLISH

### 2.3.2 Combustion Chamber Dimensions

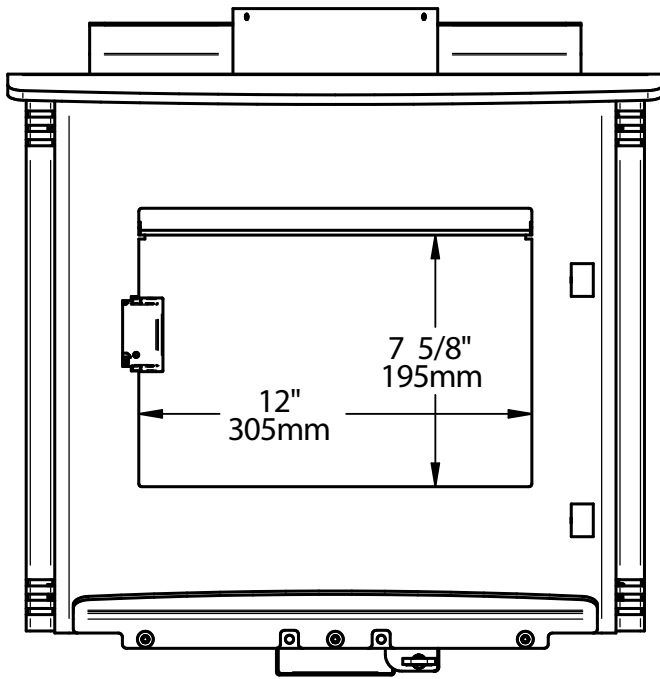

Figure 4: Door Opening

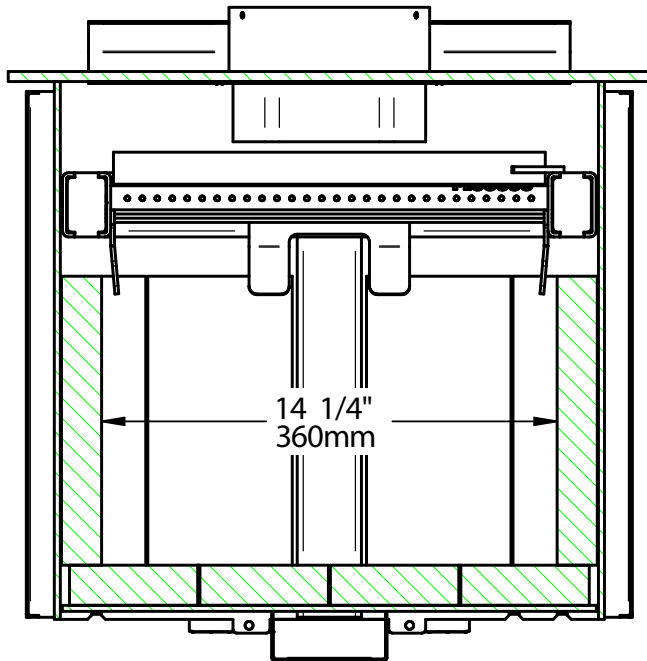

Figure 5: Front View - Combustion Chamber

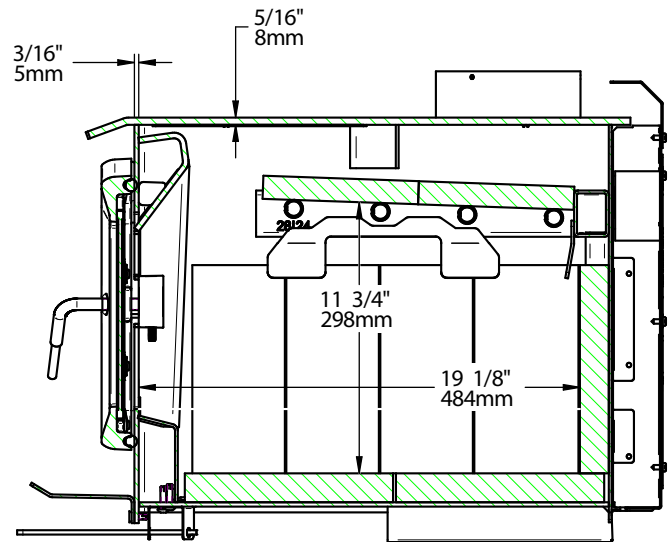

Figure 6: Side View - Combustion Chamber

## 2.4 EPA Loading

The loading methods shown below are those that were used during emissions certification.

### 2.4.1 Air control

The air control is located underneath the ash shelf. To open the air control, push the air control handle completely to the left (High). This will increase the burn rate. To close the air control, push the air control handle completely to the right (Low). This will decrease the burn rate.

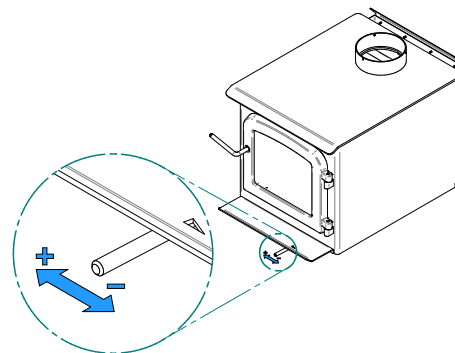

### 2.4.2 High burn rate (primary air control open)

Open the air control completely. Place six small pieces (2"x2") of wood in the firebox crossing them at the greatest possible angle. Criss cross fifteen kindling wood pieces on the small pieces of wood in three layers at the greatest possible angle. Tie knot with five sheets of paper and place them on top of the kindling wood. Light up the paper and let the door ajar at 90° until all the kindling wood is on fire and the first row of small pieces of wood is on fire too. Close the door.

When there is no more fire in the front of the firebox and there are only faint flames on the wood in the back of the firebox, break ashes, level the coal bed and put four logs in the firebox. Place the biggest log (about 5"x5") and a medium log (about 4"x4") on the coal bed with a north-south orientation. Place two other medium logs on the first two with the greatest possible angle. Their should be air space between each logs and between the logs and the bricks. Let the door ajar at 90° for approximately two minutes and then close the door.

### 2.4.3 Medium and low burn rate

On a 2" coal bed that is still slightly red, place five logs of approximately 4"x4" or 3"x3" with a north-south orientation. Place three logs on the coal bed and the other two on top with the greatest possible angle. Their should be air space between each logs and between the logs and the bricks. Let the door ajar at 90° for approximately 5 min. Then, close the door with the primary air control open. Leave to burn with the primary air control open for approximately 10 minutes and then close the primary air control completely for the low burn rate and halfway for the medium burn rate.

### 3. Clearances to Combustible Material

The clearances shown in this section have been determined by tests according to procedures set out in safety standards ULC S627 (Canada), UL 1482 (U.S.A.) and UL 737 (U.S.A.). When the stove is installed so that its surfaces are at or beyond the minimum clearances specified, combustible surfaces will not overheat under normal and even abnormal operating conditions.

**No part of the stove or flue pipe may be located closer to combustibles than the minimum clearance figures given.**

The clearances to combustible walls may be slightly different in Canada and the U.S.A. and may also differ depending on whether single or double wall flue pipe is used. Make sure to choose the correct clearance for the stove location and type of flue pipe.

The clearances of the appliance and the flue pipes must be met individually, meaning the appliance cannot be installed closer to the combustible materials than the single or double wall pipe allows. For a safe way to reduce clearances refer to section "5. Reducing Wall and Ceiling Clearances Safely" of this manual.

#### 3.1 Clearances

	APPLIANCE CLEARANCES WITH SINGLE WALL PIPE CONNECTOR	
	Canada	USA
<b>A</b>	14" (356 mm)	12" (305 mm)
<b>B</b>	12" (305 mm)	12" (305 mm)
<b>C</b>	11" (279 mm)	11" (279 mm)

	APPLIANCE CLEARANCES WITH DOUBLE WALL PIPE CONNECTOR	
	Canada	USA
<b>A</b>	6" (152 mm)	6" (152 mm)
<b>B</b>	12" (305 mm)	12" (305 mm)
<b>C</b>	6" (152 mm)	6" (152 mm)

If the above clearances are met, then the distances measured from the flue outlet will be:

	DISTANCES <sup>13</sup> FROM PIPE CONNECTOR WITH SINGLE WALL PIPE CONNECTOR	
	Canada	USA
<b>D</b>	18" (457 mm)	16" (406 mm)
<b>E</b>	18" (457 mm)	18" (457 mm)
<b>F</b>	18" (457 mm)	18" (457 mm)

	DISTANCES <sup>15</sup> FROM PIPE CONNECTOR WITH DOUBLE WALL PIPE CONNECTOR	
	Canada	USA
<b>D</b>	9 ¼" (235 mm)	9 ¼" (235 mm)
<b>E</b>	18" (457 mm)	18" (457 mm)
<b>F</b>	12 7/8" (327 mm)	12 7/8" (327 mm)

<sup>15</sup> The pipe distances listed in this table refer to the distances obtained when the stove is installed in accordance with the appliance clearances above mentioned.

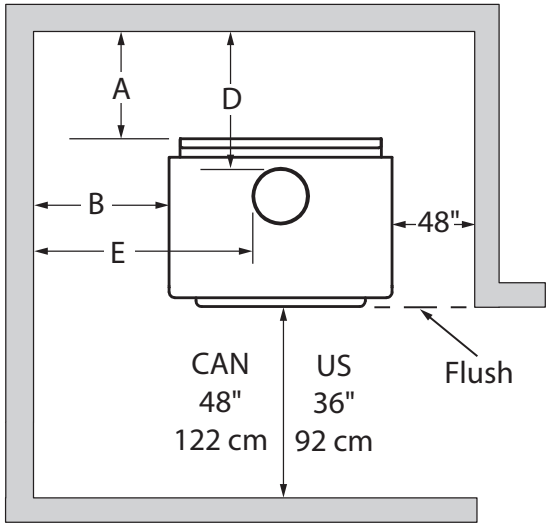

Figure 7: Clearances - Top

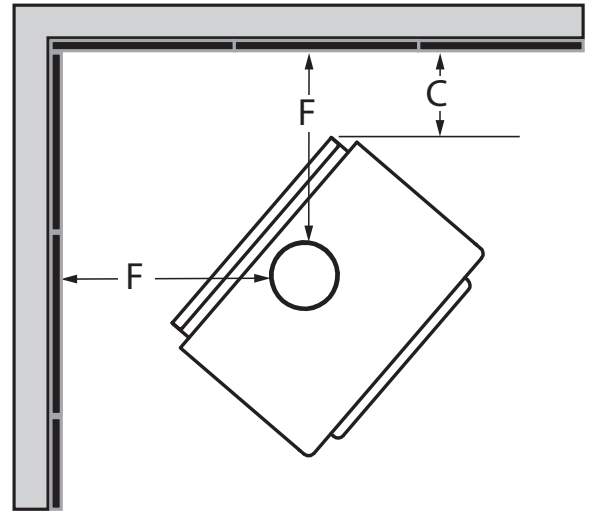

Figure 8: Clearances - Corner

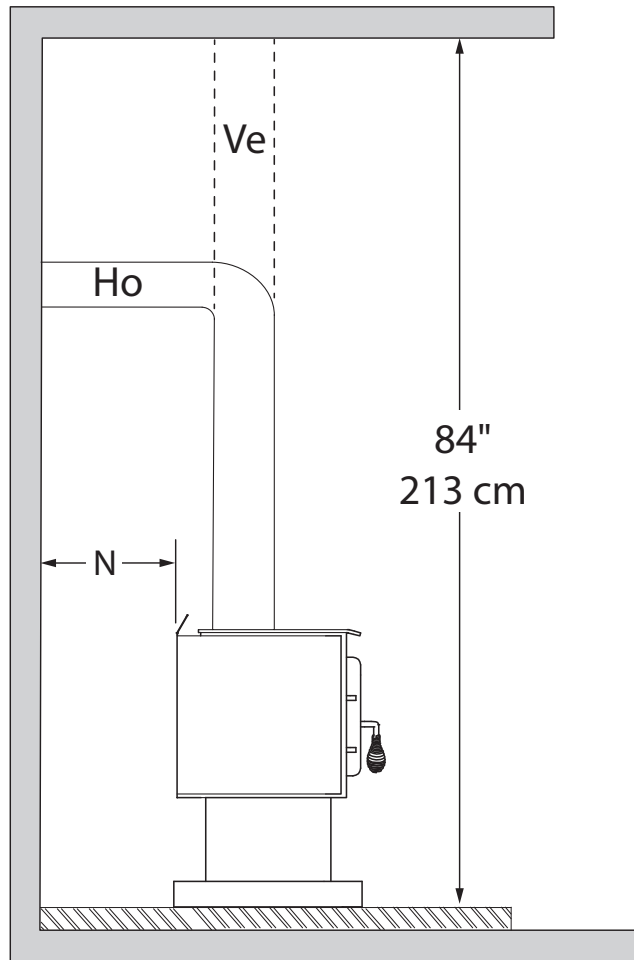

Figure 9: Clearances - Side

### 3.1.1 With Heat Shield AC02762<sup>16</sup>

To reduce the clearances of an appliance using a single wall pipe connector, the use of a heat shield certified with the single wall pipe connector to be used as close as 6" from combustible materials must be used. Only in this case, the same clearances as a certified double wall pipe connector can be used. Refer to the booklet in the screen options to obtain the dimensions to be respected.

	APPLIANCE CLEARANCES WITH DOUBLE WALL PIPE CONNECTOR	
	Canada	USA
<b>A</b>	2 ½" (64 mm)	2 ½" (64 mm)
<b>B</b>	2 ½" (64 mm)	2 ½" (64 mm)
<b>C</b>	2 ½" (64 mm)	2 ½" (64 mm)

	DISTANCES <sup>17</sup> FROM DOUBLE WALL PIPE CONNECTOR	
	Canada	USA
<b>D</b>	5 ¾" (146 mm)	5 ¾" (146 mm)
<b>E</b>	8 ½" (216 mm)	8 ½" (216 mm)
<b>F</b>	9 3/8" (238 mm)	9 3/8" (238 mm)

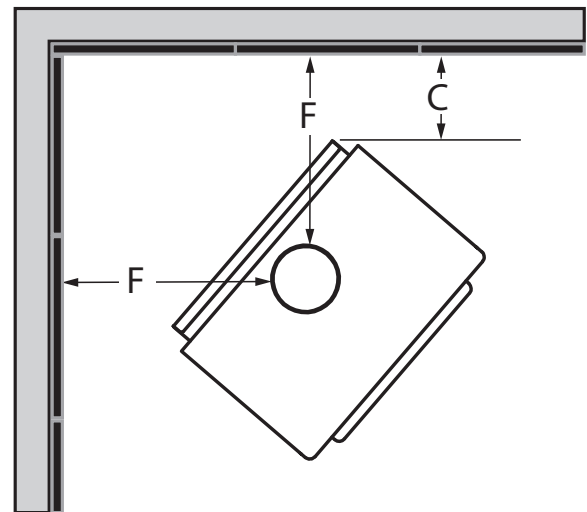
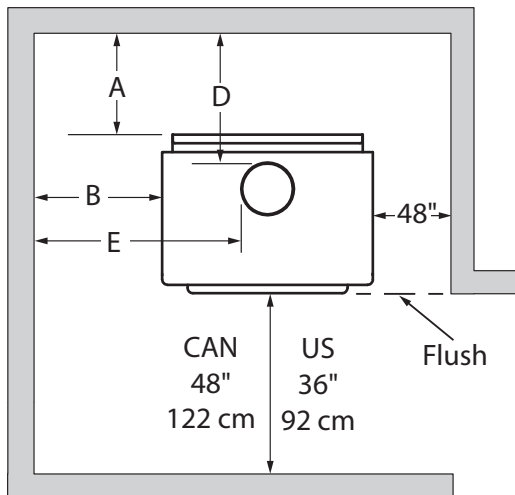

If the clearance reduction is on the same side as the door handle, position the stove at a minimum of 6 inches from the side wall (clearance B), otherwise it may be located at the clearance shown in the table above.

<sup>16</sup> Note that to reduce the clearances of an appliance using a single wall pipe connector, the use of a heat shield certified with the single wall pipe connector to be used as close as 6" from combustible materials must be used. Only in this case, the same clearances as a certified double wall pipe connector can be used.

<sup>17</sup> The pipe distances listed in this table refer to the distances obtained when the stove is installed in accordance with the appliance clearances above mentioned.

### 3.1.2 With Lowered Ceiling

	APPLIANCE CLEARANCES WITH SINGLE WALL PIPE CONNECTOR	
	Canada	USA
<b>A</b>	14" (356 mm)	14" (356 mm)
<b>B</b>	13" (330 mm)	13" (330 mm)
<b>C</b>	11" (279 mm)	11" (279 mm)
<b>L</b>	72" (1829 mm)	72" (1829 mm)

	APPLIANCE CLEARANCES WITH DOUBLE WALL PIPE CONNECTOR	
	Canada	USA
<b>A</b>	6" (152 mm)	6" (152 mm)
<b>B</b>	13" (330 mm)	13" (330 mm)
<b>C</b>	6" (152 mm)	6" (152 mm)
<b>L</b>	72" (1829 mm)	72" (1829 mm)

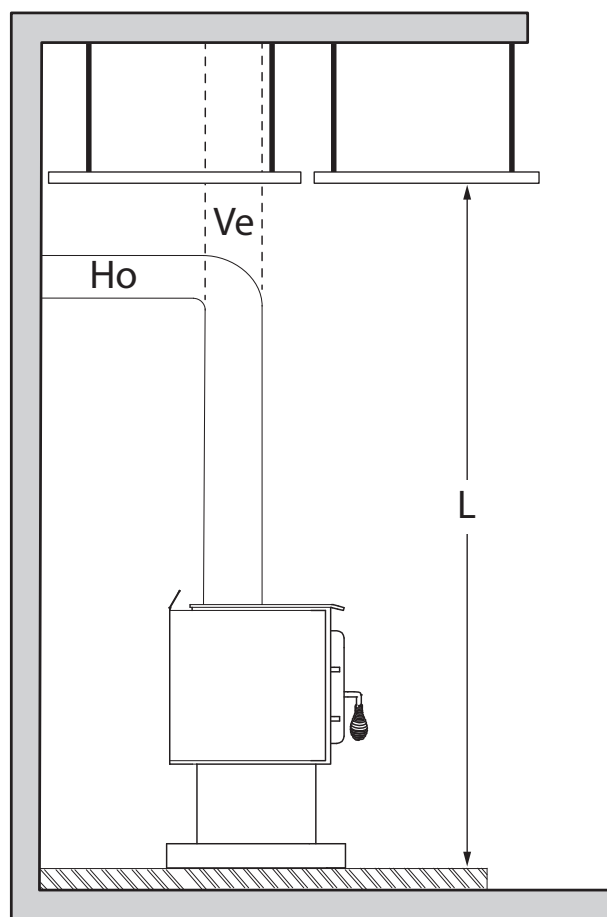

If the above clearances are met, then the distances measured from the flue outlet will be:

	DISTANCES <sup>18</sup> FROM PIPE CONNECTOR WITH SINGLE WALL PIPE CONNECTOR	
	Canada	USA
<b>D</b>	18" (457 mm)	18" (457 mm)
<b>E</b>	19" (483 mm)	19" (483 mm)
<b>F</b>	18" (457 mm)	18" (457 mm)

	DISTANCES <sup>17</sup> FROM PIPE CONNECTOR WITH DOUBLE WALL PIPE CONNECTOR	
	Canada	USA
<b>D</b>	9 ¼" (235 mm)	9 ¼" (235 mm)
<b>E</b>	19" (483 mm)	19" (483 mm)
<b>F</b>	12 7/8" (327 mm)	12 7/8" (327 mm)

<sup>18</sup> The pipe distances listed in this table refer to the distances obtained when the stove is installed in accordance with the appliance clearances above mentioned.

### 3.1.3 With Heat Shield AC02762 and Lowered Ceiling

To reduce the clearances of an appliance using a single wall pipe connector, the use of a heat shield certified with the single wall pipe connector to be used as close as 6" from combustible materials must be used. Only in this case, the same clearances as a certified double wall pipe connector can be used. Refer to the booklet in the screen options to obtain the dimensions to be respected.

	APPLIANCE CLEARANCES WITH DOUBLE WALL PIPE CONNECTOR	
	Canada	USA
<b>A</b>	2 ½" (64 mm)	2 ½" (64 mm)
<b>B</b>	2 ½" (64 mm)	2 ½" (64 mm)
<b>C</b>	2 ½" (64 mm)	2 ½" (64 mm)
<b>L</b>	74" (1880 mm)	74" (1880 mm)

	DISTANCES <sup>19</sup> FROM PIPE CONNECTOR WITH DOUBLE WALL PIPE CONNECTOR	
	Canada	USA
<b>D</b>	5 ¾" (146 mm)	5 ¾" (146 mm)
<b>E</b>	8 ½" (216 mm)	8 ½" (216 mm)
<b>F</b>	9 3/8" (238 mm)	9 3/8" (238 mm)

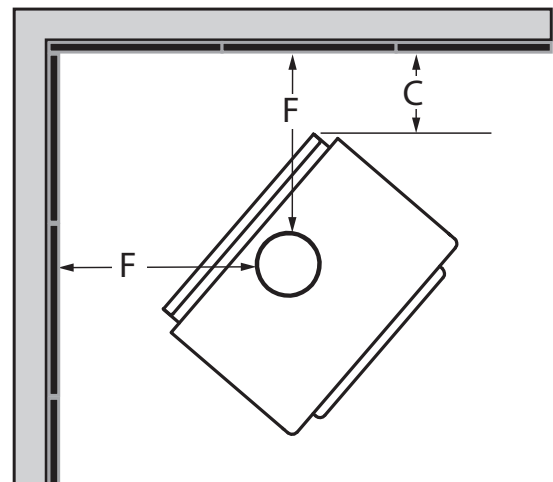
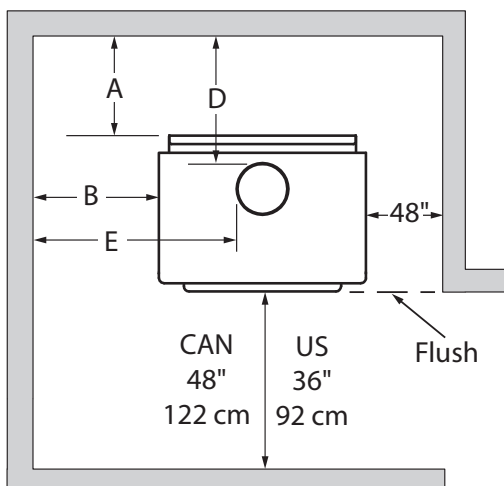
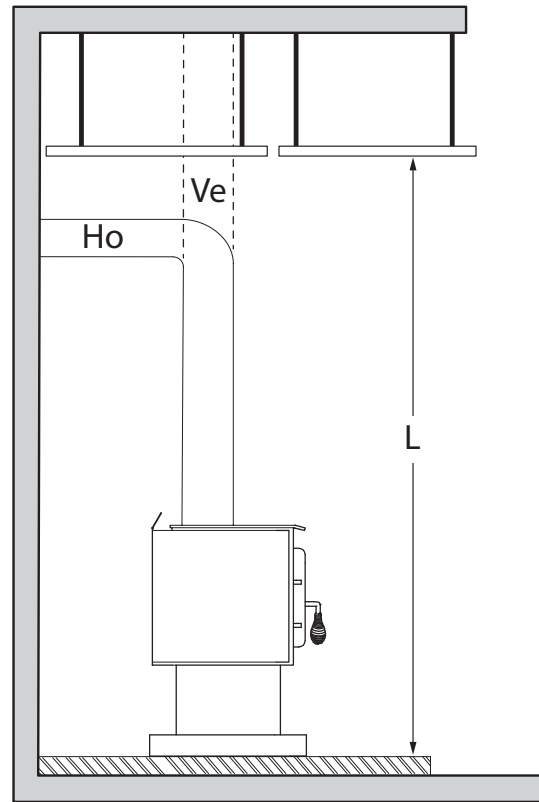

**If the clearance reduction is on the same side as the door handle, position the stove at a minimum of 6 inches from the side wall (clearance B), otherwise it may be located at the clearance shown in the table above.**

<sup>19</sup> The pipe distances listed in this table refer to the distances obtained when the stove is installed in accordance with the appliance clearances above mentioned.

### 3.1.4 Inside a Combustible Alcove

See section 3.1 for the single wall pipe installation.

	APPLIANCE CLEARANCES WITH DOUBLE WALL PIPE CONNECTOR	
	Canada	USA
<b>A</b>	6" (152 mm)	6" (152 mm)
<b>B</b>	13" (330 mm)	13" (330 mm)
<b>K</b>	48" (1219 mm)	36" (914 mm)
<b>L</b>	72" (1829 mm)	72" (1829 mm)

	DISTANCES <sup>19</sup> FROM PIPE CONNECTOR WITH DOUBLE WALL PIPE CONNECTOR	
	Canada	USA
<b>D</b>	9 1/4" (235 mm)	9 1/4" (235 mm)
<b>E</b>	19" (483 mm)	19" (483 mm)

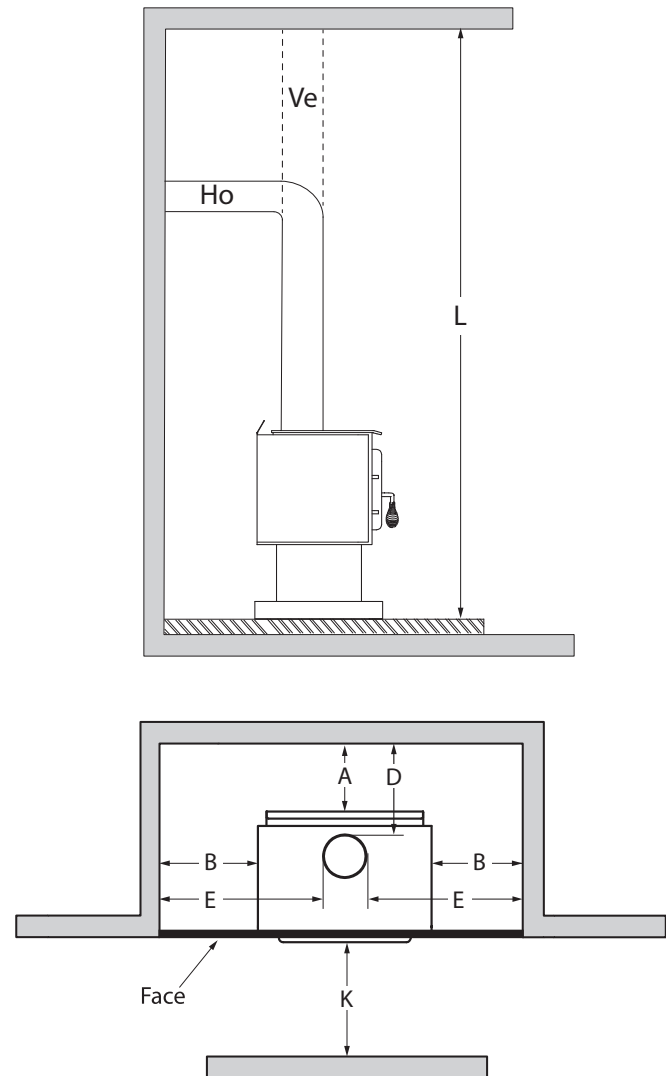

### 3.1.5 Mobile Home

It is strictly **forbidden** to install a unit with a **single wall pipe** in a **mobile home**.

	APPLIANCE CLEARANCES WITH DOUBLE WALL PIPE CONNECTOR	
	Canada	USA
<b>A</b>	6" (152 mm)	6" (152 mm)
<b>B</b>	12" (305 mm)	12" (305 mm)
<b>C</b>	6" (152 mm)	6" (152 mm)

	DISTANCES <sup>20</sup> FROM PIPE CONNECTOR WITH DOUBLE WALL PIPE CONNECTOR	
	Canada	USA
<b>D</b>	9 1/4" (235 mm)	9 1/4" (235 mm)
<b>E</b>	18" (457 mm)	18" (457 mm)
<b>F</b>	12 7/8" (327 mm)	12 7/8" (327 mm)

<sup>20</sup> The pipe distances listed in this table refer to the distances obtained when the stove is installed in accordance with the appliance clearances above mentioned.

### 3.1.6 Mobile Home With Heat Shield AC02762

It is strictly **forbidden** to install a unit with a **single wall pipe** in a **mobile home**.

	APPLIANCE CLEARANCES WITH DOUBLE WALL PIPE CONNECTOR	
	Canada	USA
<b>A</b>	3" (76 mm)	3" (76 mm)
<b>B</b>	3" (76 mm)	3" (76 mm)
<b>C</b>	3" (76 mm)	3" (76 mm)

	DISTANCES <sup>21</sup> FROM PIPE CONNECTOR WITH DOUBLE WALL PIPE CONNECTOR	
	Canada	USA
<b>D</b>	6 ¼" (159 mm)	6 ¼" (159 mm)
<b>E</b>	9" (229 mm)	9" (229 mm)
<b>F</b>	9 7/8" (251 mm)	9 7/8" (251 mm)

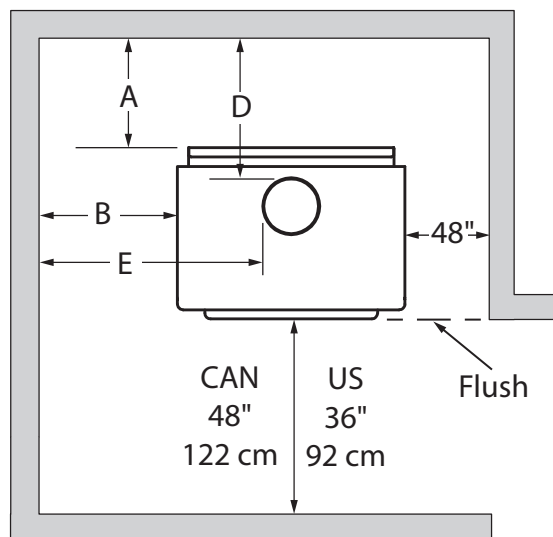

If the clearance reduction is on the same side as the door handle, position the stove at a minimum of 6 inches from the side wall (clearance B), otherwise it may be located at the clearance shown in the table above.

<sup>21</sup> Les distances de tuyau listées dans ce tableau se réfèrent aux distances obtenues lorsque le poêle est installé en accord avec les dégagements de l'appareil mentionnés ci-dessus.

## 4. Floor Protection

This stove is designed to prevent the floor from overheating. However, it must be placed on a non-flammable surface to protect the floor from hot embers that may fall during loading.

The floor protection must be a continuous, non combustible material, such as steel with a minimum thickness of 0.015" (0.38 mm) or ceramic tiles sealed together with grout. Cement board, brick, or any other approved or listed material suited for floor protection. No R factor required.

Any type of tile will require a continuous non combustible sheet beneath to prevent the possibility of embers falling through to the combustible floor if cracks or separation should occur in the finished surface. Check local codes for approved alternatives.

No protection is required if the unit is installed on a non-combustible floor (ex: concrete).

	FLOOR PROTECTION	
	Canada	USA
<b>G<sup>22</sup></b>	8" (203 mm)	N/A
<b>H</b>	8" (203 mm)	N/A
<b>I</b>	18" (457 mm) From door opening	16" (406 mm) From door opening
<b>J</b>	N/A	8" (203 mm)
<b>K</b>	35 1/2" (902 mm)	30 3/8" (772 mm)
<b>N<sup>23</sup></b>	N/A	See note 22
<b>S</b>	48 3/4" (1238 mm)	38 3/4" (984 mm)
<b>T</b>	34 1/2" (876 mm)	27 1/2" (699 mm)
<b>U</b>	35 1/2" (902 mm)	30 3/8" (772 mm)
<b>V</b>	66 1/2" (1689 mm)	54" (1372 mm)

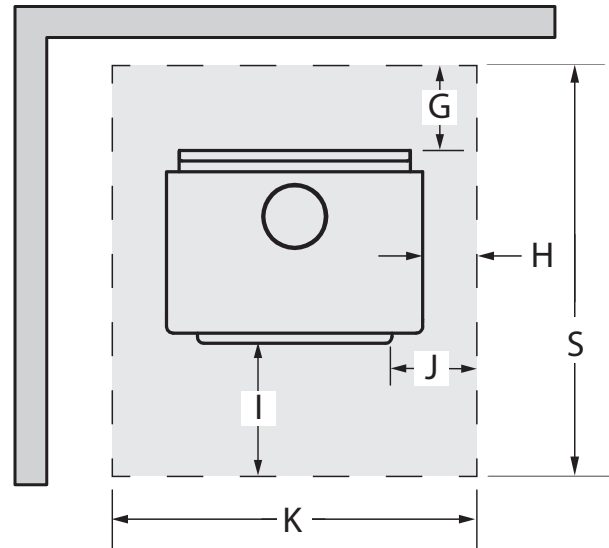
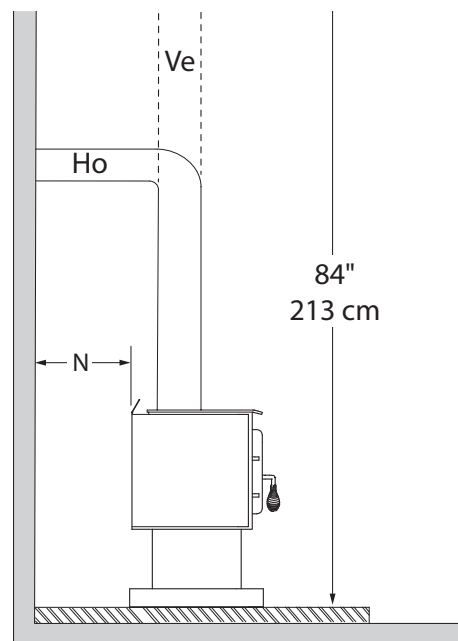
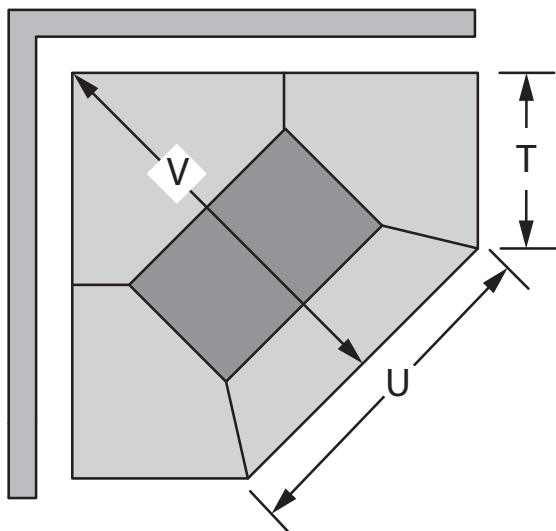

Figure 10: Floor Protection



ENGLISH

<sup>22</sup> The floor protection at the back of the stove is limited to the stove's required clearance if such clearance is smaller than 8 inches (203 mm).

<sup>23</sup> Only required under the horizontal section (Ho) of the connector. Must exceed each side of the connector by at least 2 inches (51 mm).

## 5. Reducing Wall and Ceiling Clearances Safely

It is often desired to use as little space as possible when installing a wood stove. To do this, it is possible to reduce the clearances safely and install the stove closer to the walls by permanently installing a heat shield between the stove and the flammable material.

The rules for heat shields are sometimes complicated. Read and apply the instructions carefully. Some regions may have different regulations. Consult the local building code or contact the fire department for restrictions, inspection and installation requirements in the area.

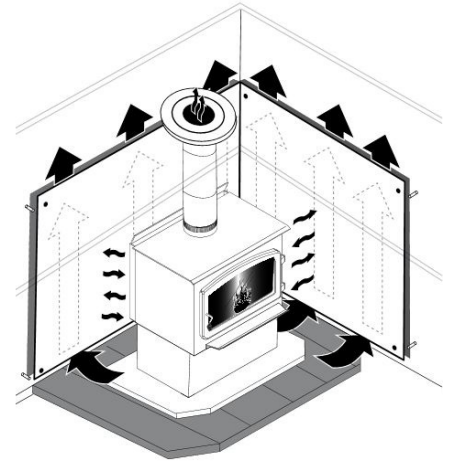

### 5.1 Shield Construction Rules

- Adhesives used in shield construction must not ignite or lose adhesive qualities at temperatures likely to be encountered.
  - Mounting hardware which extends from the shield surface into combustibles may be used only at the edges of the shield.
  - Mounting hardware must allow full vertical ventilation.
- A) Minimum clearance between the appliance top and an unshielded combustible ceiling: 47 ¼" (1200 mm)
  - B) Shield extension above the appliance: 20" (500 mm)
  - C) Minimum space behind the shield: 1" (25 mm). In Canada 7/8" (21 mm)
  - D) Clearance along the bottom of the shield: minimum 1" (25 mm) and maximum 3" (75 mm)
  - E) Minimum clearance along the top of the shield: 3" (75 mm)
  - F) Mounting hardware must not be located closer than 8" (200 mm) from the vertical centre line of the appliance.
  - G) Edge clearance for ceiling shields to side and back walls: 3" (75 mm)
  - H) Shield extension beyond each side of the appliance: 18" (450 mm)

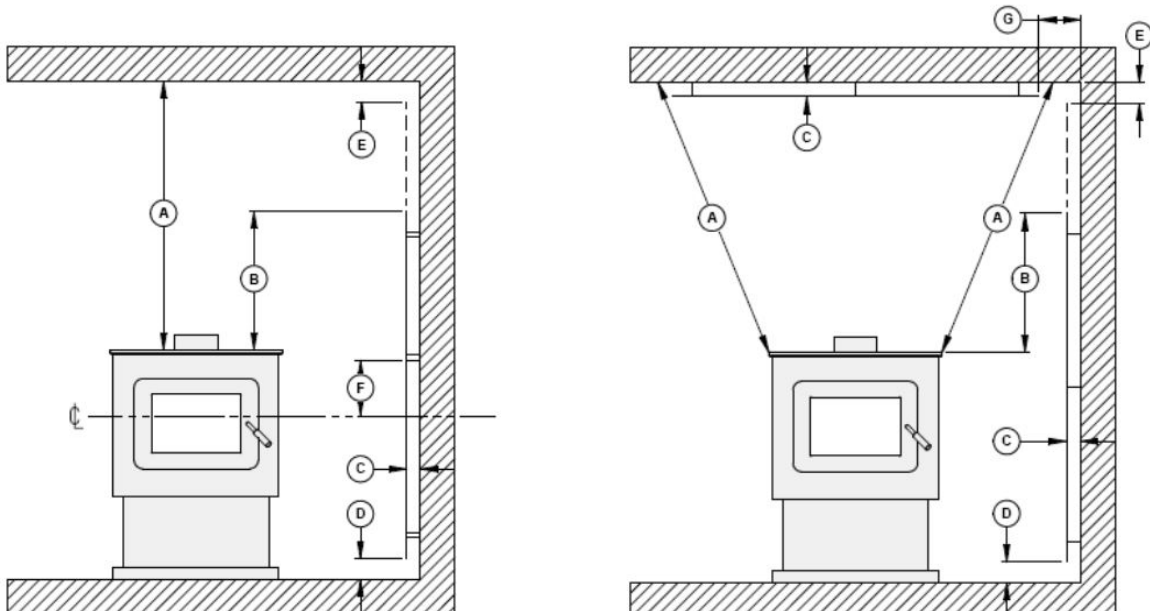

Figure 11: Heat shield clearances

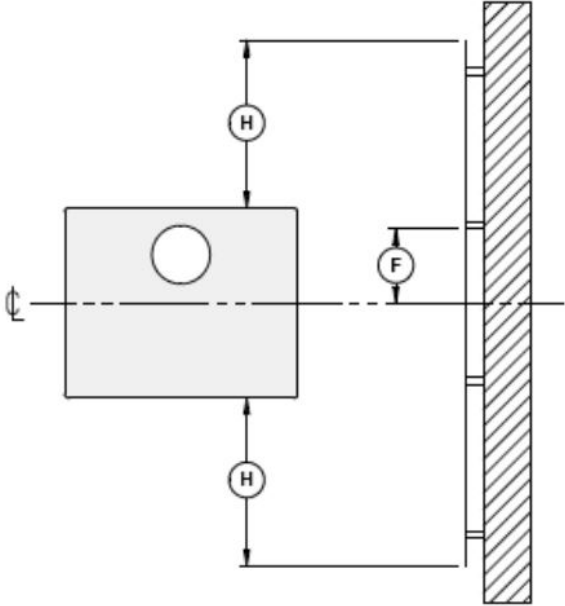

Figure 13: Heat shield clearances

Figure 12: Heat shield clearances

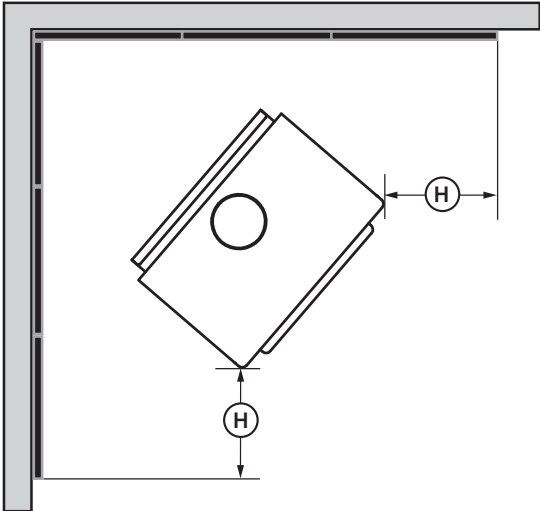
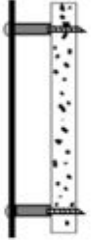
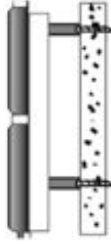

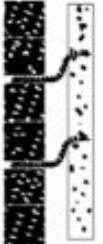
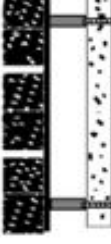

Figure 14: Heat shield clearances

TYPE OF SHIELD	CLEARANCES MAY BE REDUCED BY THESE PERCENTAGES				
	SIDES AND REAR		TOP (CEILING)		
	CAN / USA (%)	USA MIN.	CAN / USA (%)	USA MIN.	
Sheet metal, a minimum of 24 gauge (0.61 mm) in thickness , spaced out at least 1" (25 mm)* by non-combustible spacers	67	12" (305 mm)	50	18" (457 mm)	
Ceramic tiles, or equivalent non-combustible material, on non-combustible board spaced out at least 1" (25 mm)* by non-combustible spacers	50	18" (457 mm)	33	24" (610 mm)	
Ceramic tiles, or equivalent non-combustible material, on non-combustible board, with a minimum of 24 gauge (0.61 mm) sheet metal backing spaced out at least 1" (25 mm)* by non-combustible spacers	67	12" (305 mm)	50	24" (610 mm)	
Brick, spaced out at least 1" (25 mm)* by non-combustible spacers	50	18" (457 mm)	N/A	N/A	
Brick, with a minimum of 24 gauge (0.61 mm) sheet metal backing, spaced out at least 1" (25 mm)* by non-combustible spacers	67	12" (305 mm)	N/A	N/A	

\* In Canada this space can be 7/8" (21 mm)

## 6. INSTALLATION OF OPTIONS ON YOUR PRODUCT

### 6.1 Decorative Panels

THE IMAGES SHOWN ARE FOR GUIDANCE ONLY AND MAY BE DIFFERENT FROM YOUR PRODUCT, BUT THE ASSEMBLY REMAINS THE SAME.

1. To remove the decorative panel **(A)**, remove the screws **(B)** and push forward on the panel to unhook it from the bracket **(E)**.

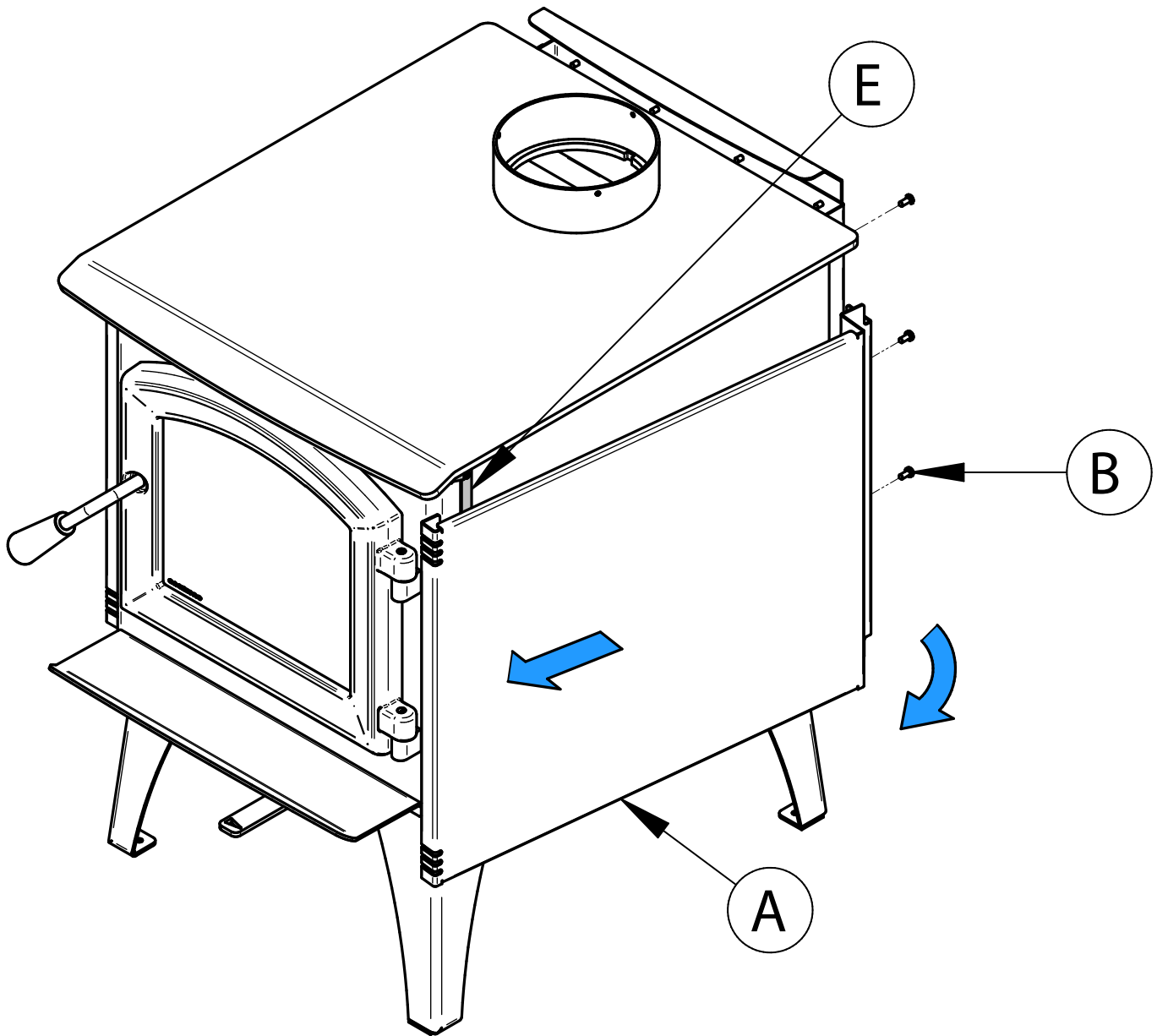

2. It is now possible to install the U-shaped decorative pieces (C) in the front fold of the decorative panels (A).

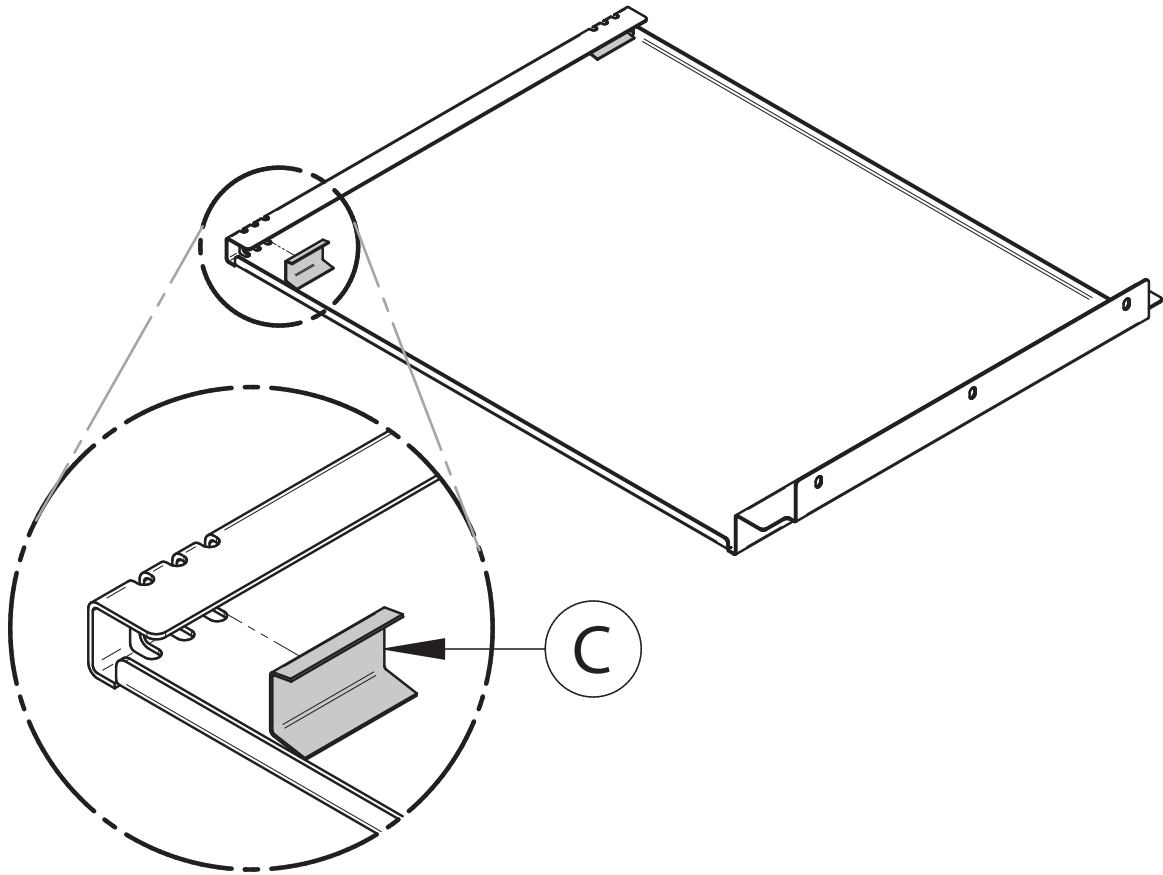

## 6.2 Optional Fresh Air Intake Kit Installation

THE IMAGES SHOWN ARE FOR GUIDANCE ONLY AND MAY BE DIFFERENT FROM YOUR PRODUCT, BUT THE ASSEMBLY REMAINS THE SAME.

This mobile home approved stove requires the installation of a fresh air intake kit **(A)** and an insulated fresh air intake pipe (HVAC type, must meet ULC S110 or UL 181 class 0 or class 1) **(B)**, sold separately. Refer to air intake kit installation instructions for more details.

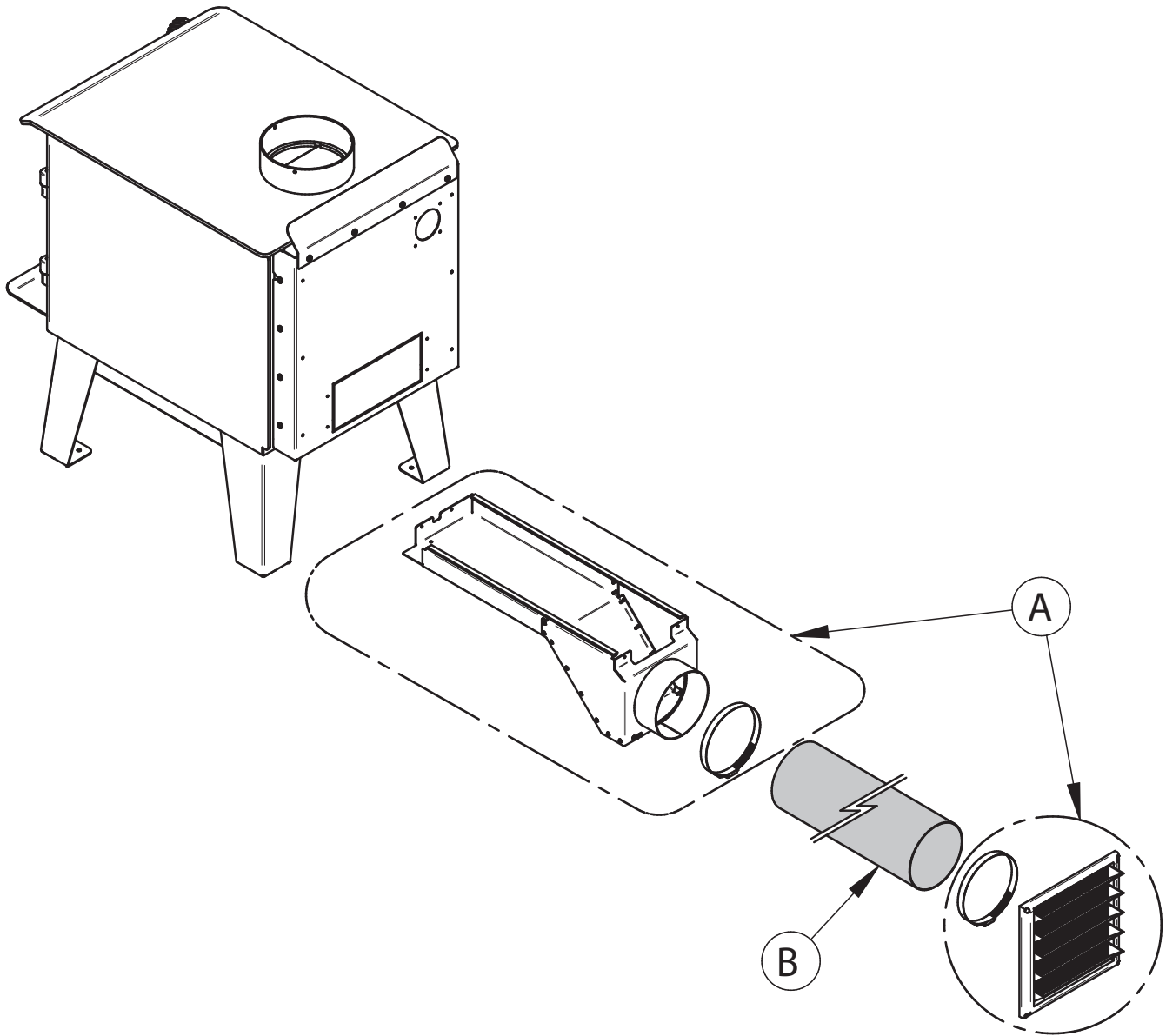

## 6.3 Optional Fire Screen Installation

THE IMAGES SHOWN ARE FOR GUIDANCE ONLY AND MAY BE DIFFERENT FROM YOUR PRODUCT, BUT THE ASSEMBLY REMAINS THE SAME.

In the United States or in provinces with a particulate emission limit (eg. US EPA), the use of wood stoves with the door open with a rigid firescreen is prohibited.

It is prohibited to use this wood stove with a fire screen in a mobile home.

1. Open the door.

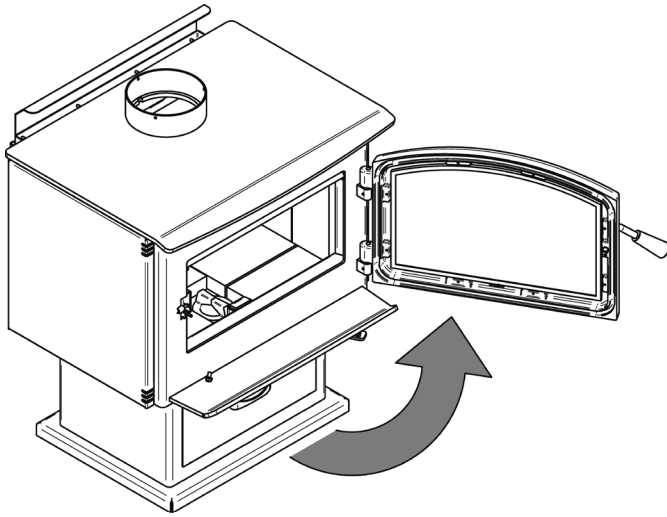

2. Hold the fire screen by the two handles and bring it close to the door opening.

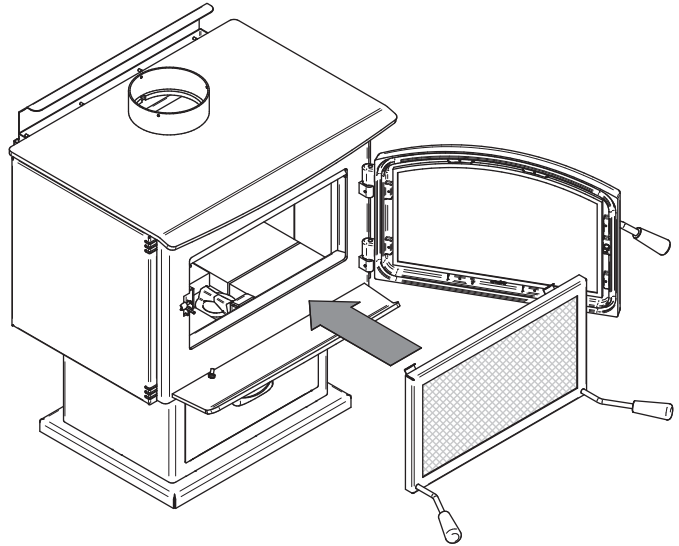

3. Lean the upper part of the fire screen against the top door opening making sure to position the top fire screen brackets behind the primary air deflector.
4. Lift the fire screen upwards and push the bottom part towards the stove then let the fire screen rest on the bottom of the door opening.

**Warning: Never leave the stove unattended while in use with the fire screen.**

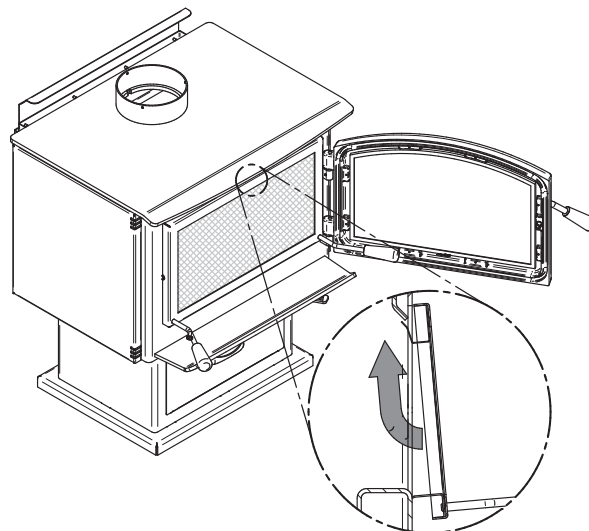

## 6.4 Optional Blower And Thermodisc Installation

THE IMAGES SHOWN ARE FOR GUIDANCE ONLY AND MAY BE DIFFERENT FROM YOUR PRODUCT, BUT THE ASSEMBLY REMAINS THE SAME.

A blower and a thermodisc, sold separately, can be installed on the stove. The installation of the blower is identical for a stove on legs or pedestal. Thermodisc allows the blower to operate only when the stove is hot enough. See the instructions provided with the thermodisc for more details.

1. Remove the backplate by cutting the knockouts with pliers.

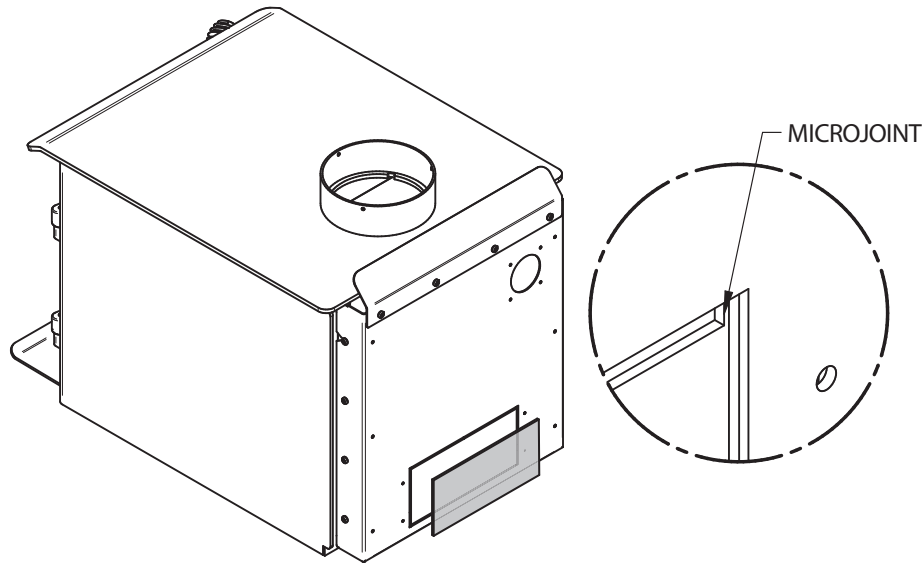

2. Screw the blower **(D)** in place using the screws **(C)** included in the installation manual. Screw the thermodisc **(A)** with the screws **(B)** supplied with the thermodisc on the back of the stove. **Ensure that the blower's power cord is not in contact with any surface of the stove to prevent electrical shock or fire damage. Do not run the power cord beneath the stove.**

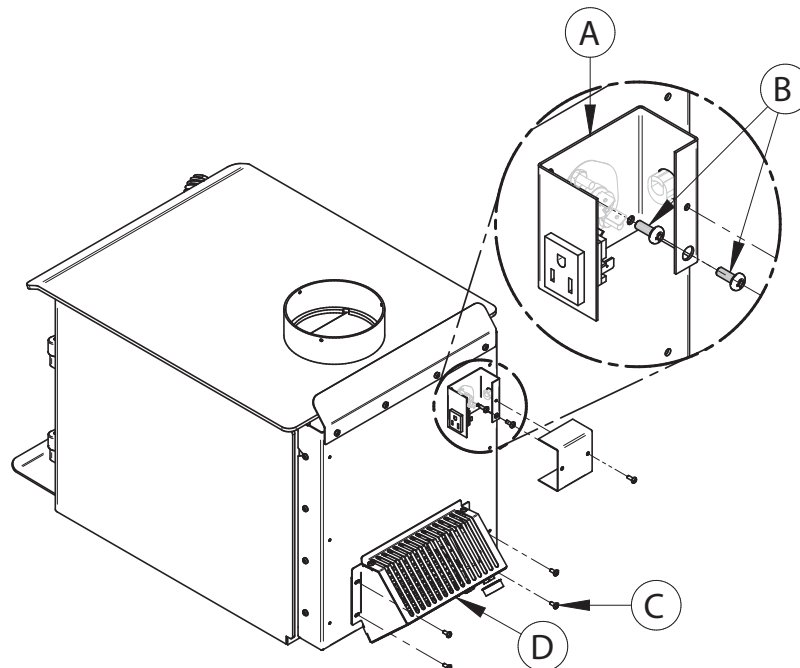

## 6.5 Air Tubes And Baffle Installation

1. Starting with the rear tube, lean and insert the right end of the secondary air tube into the rear right channel hole. Then lift and insert the left end of the tube into the rear left channel.

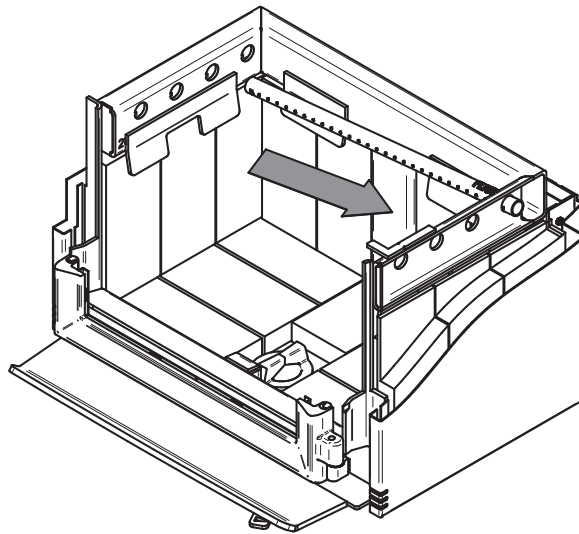

2. Align the notch in the left end of the tube with the key of the left air channel hole. Using a « Wise grip » hold the tube and lock it in place by turning the tube as shown. Make sure the notch reaches the end of the key way.

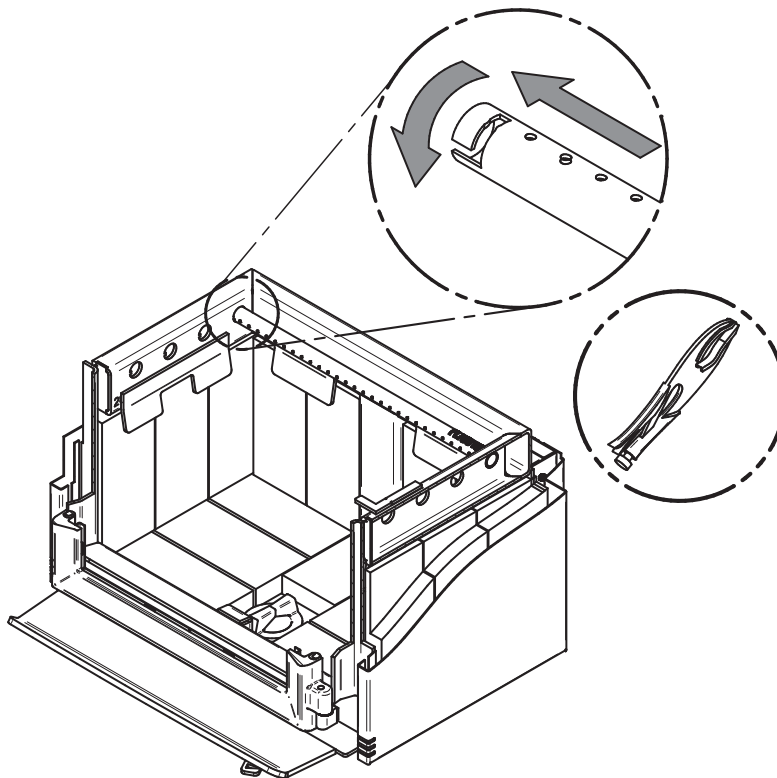

3. Put the baffle in place.
4. Repeat steps 1 and 2 for the three other tubes.
5. To remove the tubes use the above steps in reverse order.

Note that secondary air tubes (B) can be replaced without removing the baffle board (A) and that all tubes are not necessarily identical (look at the part number on the tube).

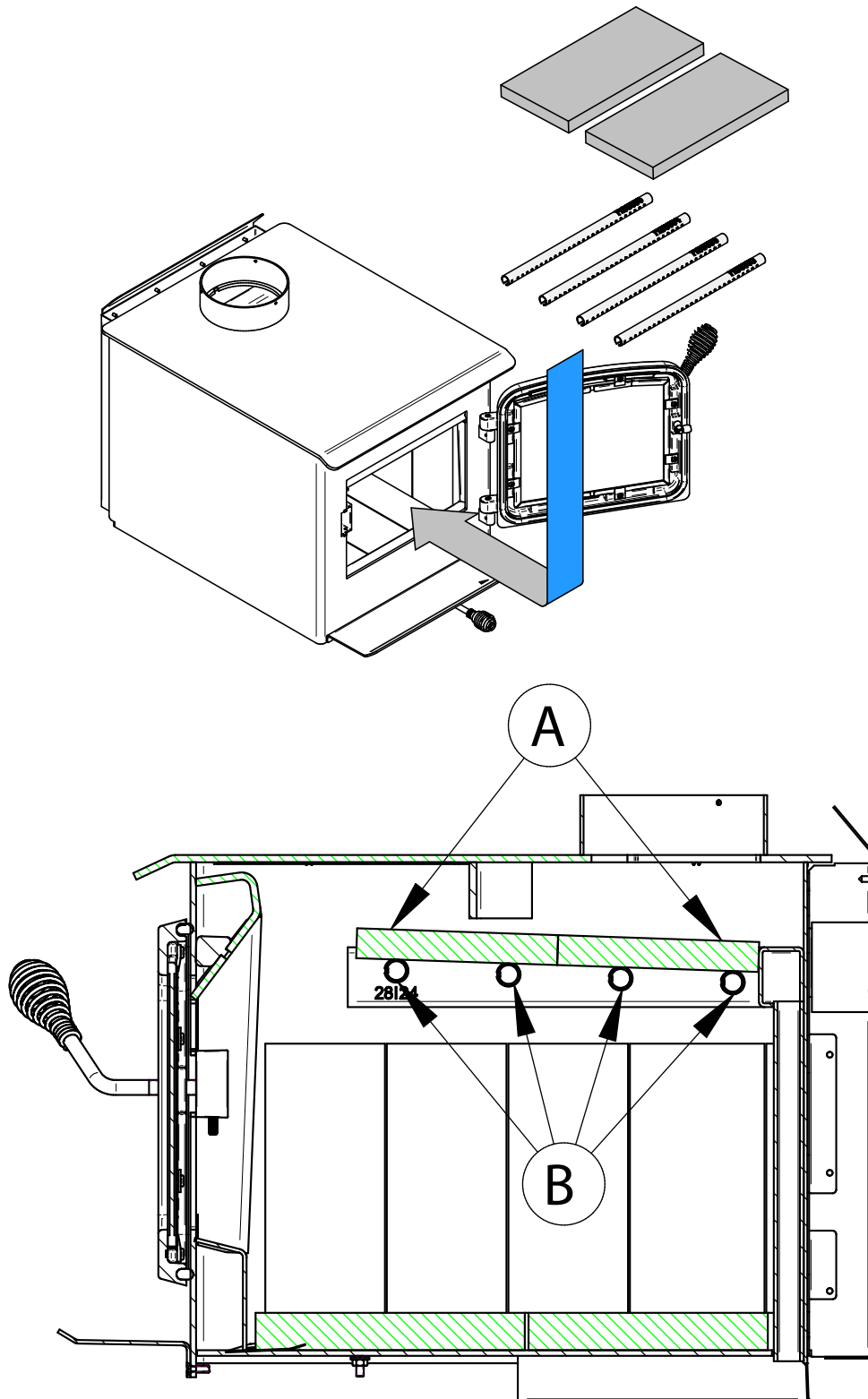

## 6.6 Mobile Home Installation

THE IMAGES SHOWN ARE FOR GUIDANCE ONLY AND MAY BE DIFFERENT FROM YOUR PRODUCT, BUT THE ASSEMBLY REMAINS THE SAME.

Screw the legs on the floor with the proper hardware **(A)**.

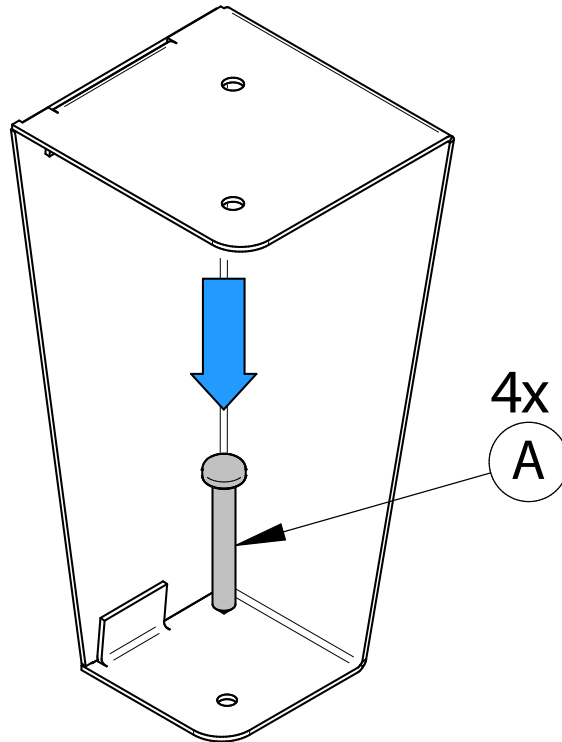

## 7. Maintenance/Parts Replacement

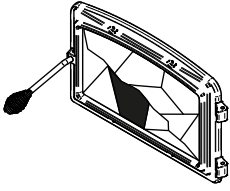

**Do not clean the glass when the stove is hot.**

**Do not abuse the glass door by striking or slamming shut.**

**Do not use the stove if the glass is broken.**

### 7.1 Replacement

The glass used is a ceramic glass, 5/32" (4 mm) thick, tested to reach temperatures up to 1400° F. If the glass breaks, it must be replaced with one having the same specification.

#### To remove or replace the glass (D):

THE IMAGES SHOWN ARE FOR GUIDANCE ONLY AND MAY BE DIFFERENT FROM YOUR PRODUCT, BUT THE ASSEMBLY REMAINS THE SAME.

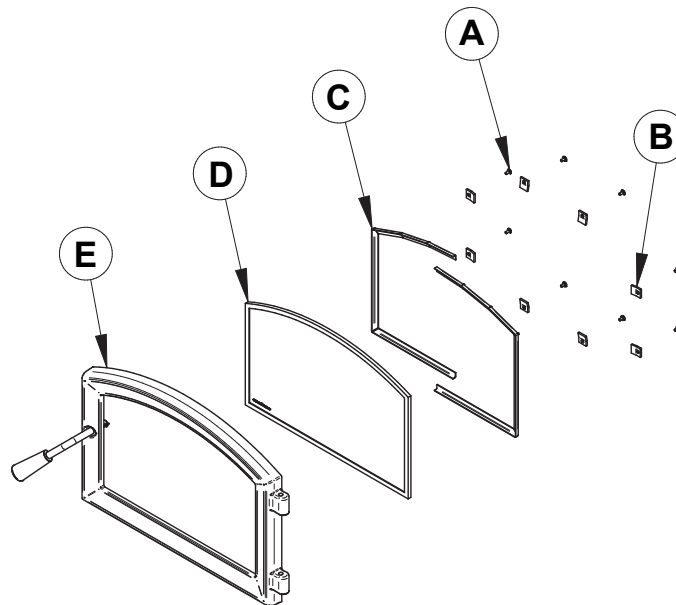

1. Remove the door **(E)** from its hinges and lay it on a soft, flat surface.
2. Remove the eight screws **(A)**, the eight glass retainers **(B)**, and the metal frames **(C)**.
3. Remove the glass **(D)**. If it is damaged install a new one in place. The replacement glass must have a gasket all around (see procedure below).
4. Reinstall the glass, being careful to centre the glass in the door and not to over-tightening the retaining screw.

*The two main causes of broken door glass are uneven placement in the door and over-tightening the retaining screws.*

## 7.2 Gasket

The glass gasket is flat, adhesive-backed, woven fibreglass. The gasket must be centred on the edge of the glass.

1. Follow the steps of the previous section to remove the glass.
2. Remove the old gasket and clean the glass thoroughly.
3. Peel back a section of the paper covering the adhesive and place the gasket on a table with the adhesive side up.
4. Stick the end of the gasket to the middle of one edge, then press the edge of the glass down onto the gasket, taking care that it is perfectly centred on the gasket.
5. Peel off more of the backing and rotate the glass. The gasket must not be stretched during installation.
6. Cut the gasket to the required length.
7. Pinch the gasket onto the glass in a U shape, all around the glass.

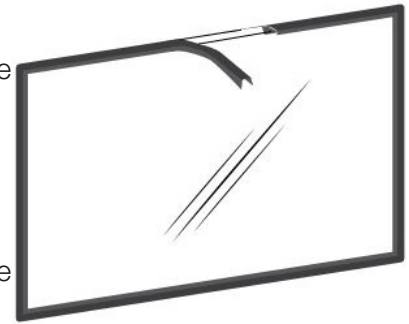

## 7.3 Door

In order for the stove to burn at its best efficiency, the door must provide a perfect seal with the firebox. The tightness of the door seal can be verified by closing and latching the door on a strip of paper. The test must be performed all around the door. If the paper slips out easily anywhere, either adjust the door or replace the gasket.

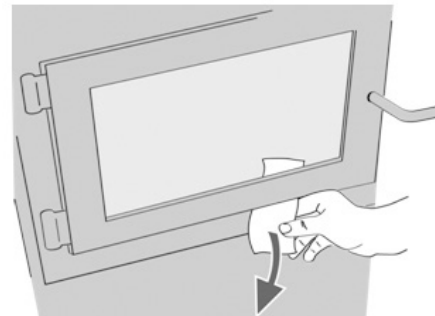

### 7.3.1 Adjustment

In order for the stove to burn at its best efficiency, the door must provide a perfect seal with the firebox. Therefore, the gasket should be inspected periodically to check for a good seal. The gasket seal may be improved with a simple latch mechanism adjustment:

1. Remove the split pin by pulling and turning it using pliers.
2. Turn the handle one counterclockwise turn to increase pressure.
3. Reinstall the split pin with a small hammer.

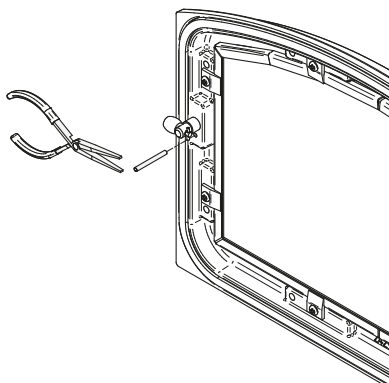

Figure 15: Removing the split pin

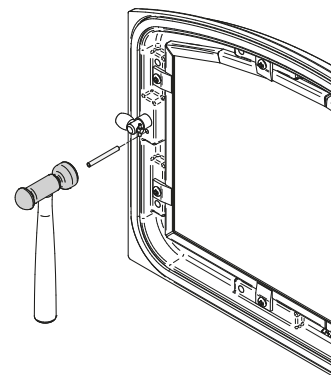
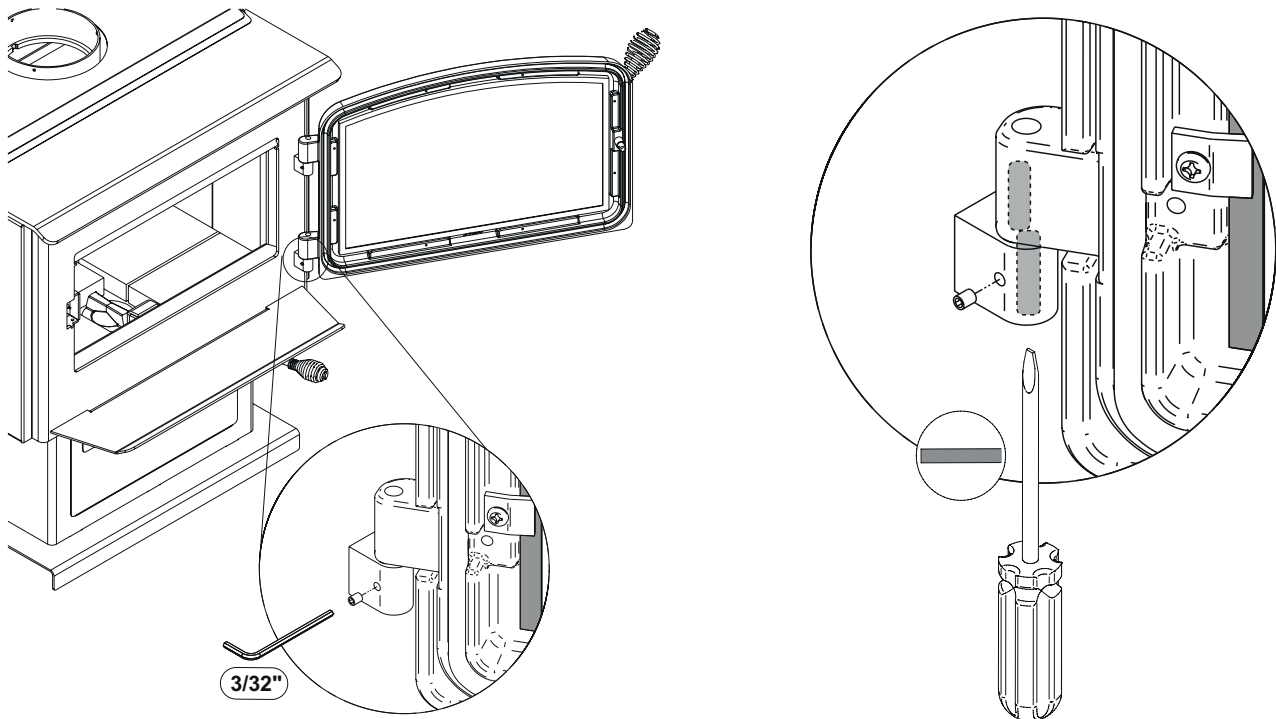

Figure 16: Installing the split pin

### 7.3.2 Door Alignment

To align, open the door and loosen the pressures screws located on the lower and upper hinges of the door using a 3/32" Allen key to free the adjustable hinge rods.



Using a flat screwdriver, turn the adjustable hinge rods in the direction shown to adjust the doors. Tighten all door hinge pressure screws when they are at the desired positions. Configurations 1-2-3-4-5-6, show in which direction these act on the adjustment of the door.

①	②	③	④
	A		A
	B		B

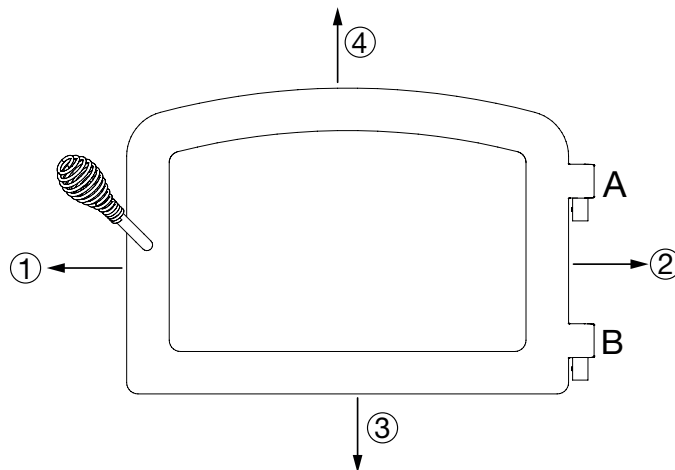
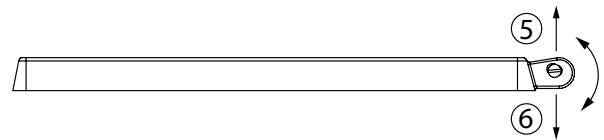

### 7.3.3 Gasket

It is important to replace the gasket with another having the same diameter and density to maintain a good seal.

1. Remove the door and place it face-down on something soft like a cushion of rags or a piece of carpet.
2. Remove the old gasket from the door. Use a screwdriver to scrape the old gasket adhesive from the door gasket groove.
3. Apply a bead of approximately 3/16" (5 mm) of high temperature silicone in the door gasket groove. Starting from the middle, hinges side, press the gasket into the groove. The gasket must not be stretched during installation.
4. Leave about 1/2" long of the gasket when cutting and press the end into the groove. Tuck any loose fibers under the gasket and into the silicone.
5. Close the door. Do not use the stove for 24 hours.

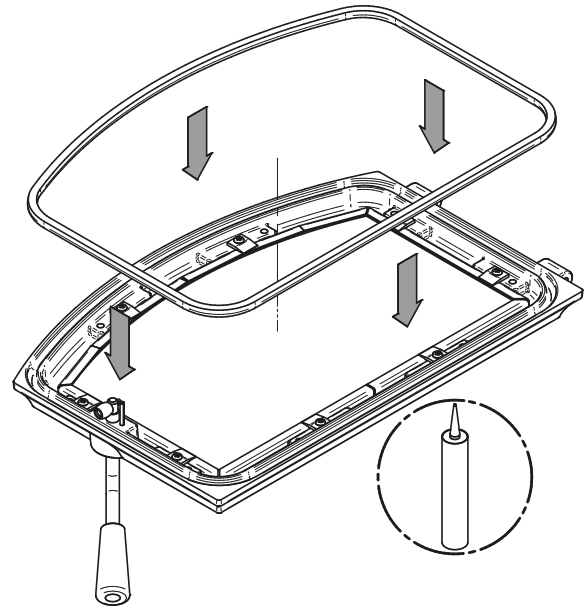

# 8. Exploded Diagram and Parts List

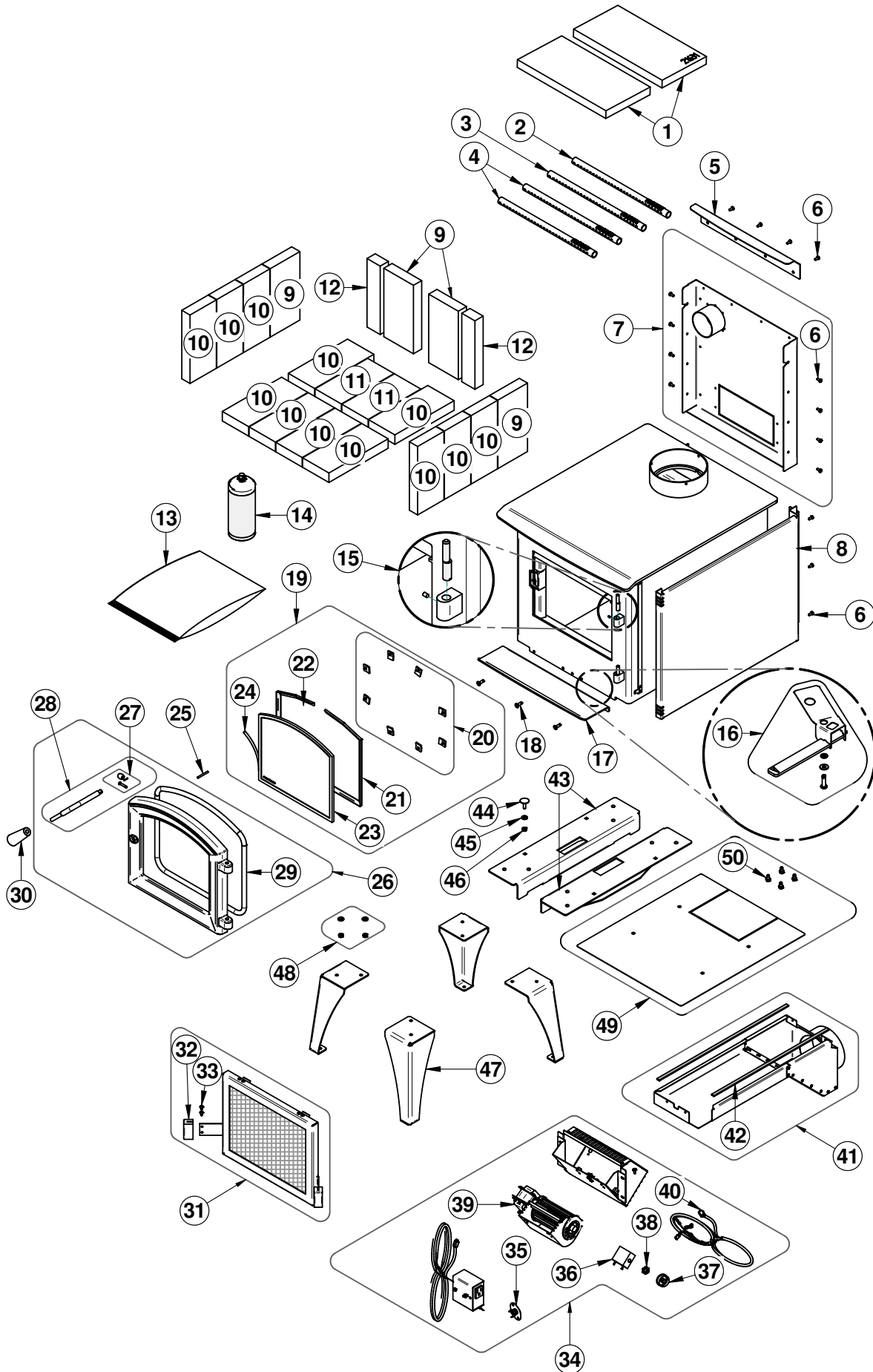

ENGLISH

IMPORTANT: THIS IS DATED INFORMATION. When requesting service or replacement parts for your unit, please provide the model number and the serial number. We reserve the right to change parts due to technology upgrades or availability. Contact an authorized dealer to obtain any of these parts. Never use substitute materials. Use of non-approved parts can result in poor performance and safety hazards.

#	Item	Description	Qty
1	21631	C-CAST BAFFLE 13 7/16" X 6 3/4" X 1"	2
2	PL66833	REAR SECONDARY AIR TUBE	1
3	PL66834	REAR CENTER SECONDARY AIR TUBE	1
4	PL66835	FRONT AND CENTER SECONDARY AIR TUBE	2
5	PL74338	AIR BAFFLE	1
6	30154	BLACK SCREW #10 X 5/8" QUADREX #2 TYPE A	18
7	SE74262	BACK HEAT SHIELD ASSEMBLY	1
8	PL74344	DECORATIVE SIDE	2
9	29020	4 1/2" X 9" X 1 1/4" REFRACTORY BRICK HD	4
10	29011	4" X 9" X 1 1/4" REFRACTORY BRICK HD	12
11	29001	4" X 8" X 1 1/4" REFRACTORY BRICK HD	2
12	PL36056	2" X 9" 1 1/4" REFRACTORY BRICK HD	2
13	SE46263	EB00061 INSTRUCTION MANUAL KIT	1
14	AC05959	METALLIC BLACK STOVE PAINT - 342 g (12oz) AEROSOL	1
15	SE74167	DOOR HINGE REPLACEMENT KIT	1
16	SE74366	ASSEMBLY AIR CONTROL HATCH KIT	1
17	PL74339	ASH TRAY	1
18	30507	BLACK TORX SCREW WITH FLAT HEAD TYPE F 1/4-20 X 3/4"	3
19	SE74371	GLASS, GASKET AND MOULDING KIT	1
20	SE53585	GLASS RETAINER KIT WITH SCREWS (12 PER KIT)	1
21	PL74347	RIGHT GLASS FRAME	1
22	PL74348	LEFT GLASS FRAME	1
23	SE74253	16 3/4" X 9 5/8" GLASS WITH GASKET	1
24	AC06400	3/4" X 6' FLAT BLACK SELF-ADHESIVE GLASS GASKET	1
25	30101	SPRING TENSION PIN 5/32"Ø X 1 1/2"L	1
26	SE24356	SOLUTION 1.4 DOOR WITH HANDLE AND GASKET	1
27	AC09185	DOOR LATCH KIT	1
28	SE65019	REPLACEMENT HANDLE WITH LATCH KIT	1
29	AC06500	SILICONE AND 5/8" X 8' BLACK DOOR GASKET KIT	1
30	30898	ROUND WOODEN BLACK HANDLE	1
31	AC01420	RIGID FIRESCREEN	1
32	PL06728	PAINTED AIR CONTROL HANDLE	2
33	30129	METAL SCREW #10 X 1/2" PAN QUADREX ZINC "A" TYPE	2
34	AC02023	BLOWER WITH THERMODISC	1
35	44028	CERAMIC THERMODISC F110-20F	1

#	Item	Description	Qty
36	44080	RHEOSTAT WITHOUT NUT (MODEL KBMS-13BV)	1
37	44085	RHEOSTAT KNOB	1
38	44087	RHEOSTAT NUT	1
39	44073	CROSSFLOW BLOWER 115V-60Hz-39W 100 CFM	1
40	60013	POWER CORD 96" X 18-3 type SJT (50 pcs per carton)	1
41	AC01421	5"Ø FRESH AIR INTAKE KIT FOR WOOD STOVE ON LEGS	1
42	AC06810	SELF ADHESIVE BLACK GASKET KIT 1/8" X 3/8" X 6'	1
43	PL74355	LEG SUPPORT	2
44	30536	LEVELING BOLT 1/4 - 20 X 1"	4
45	30185	17/64" AA TYPE WASHER BLACK	4
46	30100	BLACK HEX NUT 1/4 - 20 (NON-OILED)	4
47	PL74341	SOLUTION 1.4 LEG	4
48	30141	LEG KIT HARDWARE BAG	1
49	SE74368	BOTTOM HEAT SHIELD KIT	1
50	30060	THREAD-CUTTING SCREW 1/4-20 X 1/2" F HEX STEEL SLOT WASHER C102 ZINC	4

# ENERZONE LIMITED LIFETIME WARRANTY

The warranty of the manufacturer extends only to the original retail purchaser and is not transferable. This warranty covers brand new products only, which have not been altered, modified nor repaired since shipment from factory. Proof of purchase (dated bill of sale), model name and serial number must be supplied when making any warranty claim to your ENERZONE dealer.

**This warranty applies to normal residential use only. This warranty is void if the unit is used to burn material other than cordwood (for which the unit is not certified by EPA) and void if not operated according to the owner's manual. Damages caused by misuse, abuse, improper installation, lack of maintenance, over firing, negligence or accident during transportation, power failures, downdrafts, venting problems or under-estimated heating area are not covered by this warranty. The recommended heated area for a given appliance is defined by the manufacturer as its capacity to maintain a minimum acceptable temperature in the designated area in case of a power failure.**

This warranty does not cover any scratch, corrosion, distortion, or discoloration. Any defect or damage caused by the use of unauthorized or other than original parts voids this warranty. An authorized qualified technician must perform the installation in accordance with the instructions supplied with this product and all local and national building codes. Any service call related to an improper installation is not covered by this warranty.

The manufacturer may require that defective products be returned or that digital pictures be provided to support the claim. Returned products are to be shipped prepaid to the manufacturer for investigation. Transportation fees to ship the product back to the purchaser will be paid by the manufacturer. Repair work covered by the warranty, executed at the purchaser's domicile by an authorized qualified technician requires the prior approval of the manufacturer. All parts and labour costs covered by this warranty are limited according to the table below.

The manufacturer, at its discretion, may decide to repair or replace any part or unit after inspection and investigation of the defect. The manufacturer may, at its discretion, fully discharge all obligations with respect to this warranty by refunding the wholesale price of any warranted but defective parts. The manufacturer shall, in no event, be responsible for any uncommon, indirect, consequential damages of any nature, which are in excess of the original purchase price of the product. **A one-time replacement limit applies to all parts benefiting from lifetime coverage.** This warranty applies to products purchased after September 1<sup>st</sup>, 2015.

DESCRIPTION	WARRANTY APPLICATION*	
	PARTS	LABOUR
Combustion chamber (welds only) and cast iron door frame	Lifetime***	5 years
Ceramic glass**, plating (manufacturing defect**) and convector air-mate	Lifetime***	N/A
Surrounds, heat shields, ash drawer, steel legs, pedestal, trims (aluminum extrusions), vermiculite, C-Cast or equivalent baffle**, secondary air tubes**, removable stainless steel combustion chamber, deflectors and supports	7 years***	N/A
Handle assembly, glass retainers and air control mechanism	5 years	3 years
Removable carbon steel combustion chamber components	5 years	N/A
Standard and optional blower, heat sensors, switches, rheostat, wiring and electronics	2 years	1 year
Paint (peeling**), gaskets, insulation, ceramic fiber blankets, refractory bricks (fireplace only***), and other options	1 year	N/A
All parts replaced under the warranty	90 days	N/A

*\*Subject to limitations above    \*\*Picture required    \*\*\*Limited to one replacement*

Labour cost and repair work to the account of the manufacturer are based on a predetermined rate schedule and must not exceed the wholesale price of the replacement part.

Shall your unit or a components be defective, contact immediately your ENERZONE dealer. To accelerate processing of your warranty claim, make sure to have on hand the following information when calling:

- Your name, address and telephone number
- Bill of sale and dealer's name
- Installation configuration
- Serial number and model name as indicated on the nameplate fixed to the back of your unit
- Nature of the defect and any relevant information

**Before shipping your unit or defective component to our plant, you must obtain an Authorization Number from your ENERZONE dealer. Any merchandise shipped to our plant without authorization will be refused automatically and returned to sender.**

Wood\_Revision: June 2021



This document is available for free download on the manufacturer's website. It is a copyrighted document. Resale is strictly prohibited. The manufacturer may update this document from time to time and cannot be responsible for problems, injuries, or damages arising out of the use of information contained in any document obtained from unauthorized sources.

**enerzone**

Stove Builder International inc.  
250, rue de Copenhague,  
St-Augustin-de-Desmaures (Québec) Canada  
G3A 2H3  
1-877-356-6663  
<https://www.enerzone-intl.com/en/>  
[tech@sbi-international.com](mailto:tech@sbi-international.com)