

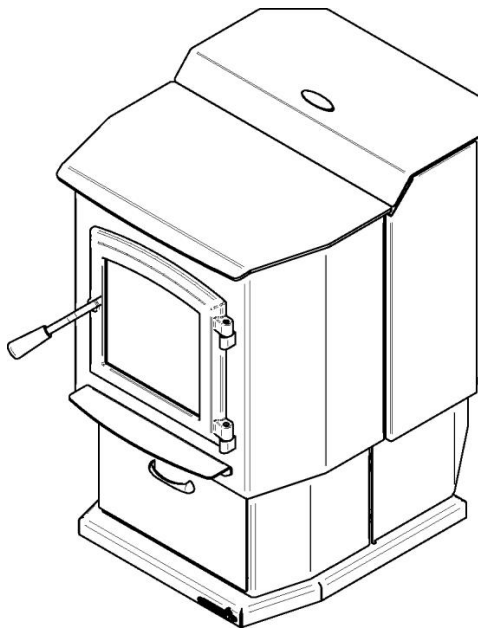

## Cambridge (EP00075 Model)



# INSTALLATION AND OPERATION MANUAL

**INSTALLATION BY A  
PROFESSIONAL IS STRONGLY  
RECOMMENDED**

Safety tested according to ULC S627,  
UL1482 and ASTM E1509  
by an accredited laboratory.



[www.enerzone-intl.com](http://www.enerzone-intl.com)

**Stove Builder International Inc.**  
250, rue de Copenhague,  
St-Augustin-de-Desmaures (Quebec)  
Canada G3A 2H3

After-sale service: 418-908-8002  
E-mail: tech@sbi-international.com

**CONTACT LOCAL BUILDING OR FIRE OFFICIALS ABOUT RESTRICTIONS AND INSTALLATION INSPECTION REQUIREMENTS IN YOUR AREA.**

**PLEASE READ THIS ENTIRE MANUAL BEFORE INSTALLATION AND USE OF THIS PELLET FUEL-BURNING ROOM HEATER. FAILURE TO FOLLOW THESE INSTRUCTIONS COULD RESULT IN PROPERTY DAMAGE, BODILY INJURY OR EVEN DEATH.**

**READ AND KEEP THIS MANUAL FOR REFERENCE**



*This manual is available for free download on the manufacturer's web site. It is a copyrighted document. Re-sale is strictly prohibited. The manufacturer may update this manual from time to time and cannot be responsible for problems, injuries, or damages arising out of the use of information contained in any manual obtained from unauthorized sources.*

## THANK YOU FOR CHOOSING THIS ENERZONE PELLET STOVE

As one of North America's largest and most respected pellet stove, wood stove and fireplace manufacturers, Stove Builder International takes pride in the quality and performance of all its products. We want to help you get maximum satisfaction as you use this product.

In the pages that follow you will find general advice on pellet heating, detailed instructions for safe and effective installation, and guidance on how to get the best performance from this stove as you build and maintain your pellet heating system.

We highly recommend that our pellet burning hearth products be installed and serviced by professionals who are certified in the United States by NFI (National Fireplace Institute®) or in Canada by WETT (Wood Energy Technology Transfer) or in Quebec by APC (Association des Professionnels du Chauffage).

Congratulations on making a wise purchase.

**If this appliance is not properly installed, combustible materials near it may overheat. To reduce the risk of fire, follow the installation instructions in this manual exactly. Contact local building or fire officials about restrictions and installation inspection requirements in your area.**

Please read this entire manual before you install and use your new stove. You may need to get a building permit for the installation of this appliance and the venting system that it is connected to. Consult your municipal building department or fire department before installation. We recommend that you also inform your home insurance company to find out if the installation will affect your policy.

A primary heat source should be available in the home. This heating unit may serve as a supplementary heat source. The manufacturer cannot be responsible for additional heating costs associated with the use of an alternative heat source.

### CAUTION

- **THE INFORMATION GIVEN ON THE CERTIFICATION LABEL AFFIXED TO THE APPLIANCE ALWAYS OVERRIDES THE INFORMATION PUBLISHED, IN ANY OTHER MEDIA (OWNER'S MANUAL, CATALOGUES, FLYERS, MAGAZINES AND/OR WEB SITES).**
- **MIXING OF APPLIANCE COMPONENTS FROM DIFFERENT SOURCES OR MODIFYING COMPONENTS IS PROHIBITED AND WILL VOID THE WARRANTY. ANY MODIFICATION OF THE FIREPLACE THAT HAS NOT BEEN APPROVED IN WRITING BY THE TESTING AUTHORITY IS PROHIBITED AND VIOLATES CSA B365 (CANADA) AND NFPA 211 (USA).**
- **STOVE BUILDER INTERNATIONAL INC. (SBI) GRANTS NO WARRANTY, IMPLIED OR STATED, FOR THE POOR INSTALLATION OR LACK OF MAINTENANCE OF YOUR APPLIANCE AND ASSUMES NO RESPONSIBILITY OF ANY CONSEQUENTIAL DAMAGES.**

# Table of contents

<b>1</b>	<b>CAMBRIDGE GENERAL INFORMATIONS (EP00075)</b> .....	<b>6</b>
1.1	Appliance performance <sup>(1)</sup> .....	6
1.2	General Features.....	7
1.3	Overall Exterior Dimensions .....	8
<b>PART A – INSTALLATION</b> .....		<b>9</b>
<b>2</b>	<b>INSTALLATION SAFETY INFORMATION</b> .....	<b>9</b>
2.1	Warnings and Cautions .....	9
2.2	Regulations Covering Pellet Stove Installation .....	11
2.3	Before Operating Your Stove .....	11
<b>3</b>	<b>CLEARANCES TO COMBUSTIBLE MATERIALS</b> .....	<b>12</b>
3.1	Certification Label Location .....	12
3.2	Clearances to combustibles materials, walls and ceiling.....	12
3.3	Floor Protection .....	14
<b>4</b>	<b>VENTING SYSTEM</b> .....	<b>15</b>
4.1	General.....	15
4.2	Recommendations .....	15
4.3	Equivalent Vent Length (EVL).....	15
4.3.1	<i>Recommended Exhaust Venting Diameter</i> .....	15
4.3.2	<i>Installation compliance</i> .....	17
4.4	Termination Location .....	17
4.4.1	<i>Permitted Termination Location</i> .....	18
4.5	Installation Configurations.....	19
4.5.1	<i>Installation Warnings, Cautions and Recommendations Reminder</i> .....	19
4.5.2	<i>Through Wall Installation (Main Floor or Basement)</i> .....	20
4.5.3	<i>Through Roof Installation</i> .....	21
4.5.4	<i>Through a Factory Built Chimney</i> .....	22
4.5.5	<i>Through an Existing Masonry Fireplace</i> .....	23
4.5.6	<i>Through an Existing Masonry Chimney</i> .....	24
<b>PART B - OPERATION</b> .....		<b>25</b>
<b>5</b>	<b>GENERAL INFORMATION</b> .....	<b>25</b>
5.1	Operation Warnings, Cautions and Recommendations .....	25
5.1.1	<i>Zone Heating and How to Make It Work for You</i> .....	27
5.2	Combustible .....	28
5.2.1	<i>Proper Fuel</i> .....	28
5.2.2	<i>Where to Store Bags of Pellets</i> .....	28
<b>6</b>	<b>STOVE CONTROLS</b> .....	<b>28</b>
6.1	General Information .....	28
6.1.1	<i>Touch Screen Controls, Operation and Configuration</i> .....	29
6.1.2	<i>Configuration and Operation Diagram</i> .....	31
6.1.3	<i>Selecting the Language and Temperature Unit (°F or °C)</i> .....	31
6.1.4	<i>Viewing Statistics</i> .....	31
6.1.5	<i>Adjusting the Combustion Level (Heat Output)</i> .....	32
6.1.6	<i>Combustion Settings and Pilot Settings depending on Fuel Quality</i> .....	33
6.1.7	<i>Convection Fan Speed Adjustment</i> .....	34
6.1.8	<i>Selecting Manual or Thermostatic Mode</i> .....	35

6.1.9	Selecting the Pilot Cycle .....	36
6.1.10	Purging the pellet feeding systems .....	37
6.1.11	Demo Mode .....	38
<b>7</b>	<b>STOVE OPERATION .....</b>	<b>39</b>
7.1	First Startup.....	39
7.2	Everyday Startup .....	39
7.3	Running Out of Pellets .....	39
7.4	Refueling .....	40
7.5	Shutting Down Procedure .....	40
7.6	Signs of an Overheating Stove .....	40
<b>8</b>	<b>MAINTENANCE .....</b>	<b>41</b>
8.1	Stove Maintenance .....	41
8.1.1	Recommended Maintenance Schedule .....	41
8.1.2	Cleaning the Baffle and the Combustion Chamber.....	42
8.1.3	Exhaust Channel and Exhaust Blower Maintenance.....	44
8.1.4	Cleaning the Burn Pot .....	47
8.1.5	Ash Removal.....	48
8.1.6	Cleaning the Air Wash System .....	49
8.1.7	Glass Care.....	50
8.1.8	Replacement of Broken Door Glass.....	50
8.1.9	Door Gasket Maintenance .....	50
8.1.10	Door Adjustment .....	51
8.2	Venting System Maintenance .....	51
8.2.1	Dealing With a Chimney Fire.....	52
8.2.2	Soot and Fly Ash .....	52
<b>9</b>	<b>TROUBLESHOOTING.....</b>	<b>53</b>
9.1	Validating Status .....	53
9.2	Testing Components .....	55
9.3	Main Error Codes, Possible Causes and Solutions .....	55
9.3.1	Blocked Flue .....	56
9.3.2	No Fuel .....	57
9.3.3	Failed Ignition.....	59
9.3.4	Defective Igniter Fuse.....	60
9.3.5	Auger Fuse.....	60
9.3.6	Unit Overheat.....	61
9.3.7	Hopper Lid Open.....	62
9.3.8	Power Loss.....	63
9.3.9	Smoke Smell .....	63
9.3.10	Combustion Air Starvation .....	64
9.3.11	The LCD Touch Screen Does Not Lightup. ....	64
<b>10</b>	<b>WIRING DIAGRAM .....</b>	<b>65</b>
<b>11</b>	<b>ACCESS TO FUSES.....</b>	<b>66</b>
<b>12</b>	<b>COMPONENTS LOCATION .....</b>	<b>67</b>
<b>13</b>	<b>BLOWER REPLACEMENT.....</b>	<b>69</b>
13.1	Convection blower .....	69
13.2	Combustion blower.....	70
13.3	Exhaust blower.....	71

14 L-250 AND F-160 THERMAL SWITCH REPLACEMENT..... 73  
15 EXPLODED VIEW AND REPLACEMENT PARTS ..... 74  
APPENDIX A: HORIZONTAL AND VERTICAL VENT CHART ..... 85  
APPENDIX B: CONNECTING AND INSTALLING THE TOUCHSCREEN ..... 87  
APPENDIX C: INSTALLING A THERMOSTAT (AC05558) ..... 88  
APPENDIX D: MOBILE HOME INSTALLATION ..... 90  
APPENDIX E: COMBUSTION AIR SUPPLY ..... 92  
ENERZONE LIMITED LIFETIME WARRANTY ..... 94

**REGISTER YOUR WARRANTY ONLINE**

To receive full warranty coverage, you will need to show evidence of the date you purchased your stove. Keep your sales invoice. We also recommend that you register your warranty online at:

<http://enerzone-intl.com/warranty-registration.aspx>

Registering your warranty online will help us to quickly track the information we need about your stove.

# 1 CAMBRIDGE GENERAL INFORMATIONS (EP00075)

## 1.1 Appliance performance<sup>(1)</sup>

Fuel type	Wood Pellet (Premium grade or better) <sup>(†)</sup>	
Recommended heating area <sup>[*]</sup>	500 to 2,200 ft <sup>2</sup> (46 to 185 m <sup>2</sup> )	
Hopper capacity	60 lb (27 kg)	
Maximum burn time <sup>[*]</sup>	50 h	
Maximum heat input rate <sup>(2)</sup>	43,000 BTU/h (12.6 kW)	
Overall heat output rate (min. to max.) <sup>(3)</sup>	6,400 BTU/h to 29,300 BTU/h (1.9 kW to 8.6 kW)	
Average overall efficiency <sup>(3)</sup>	69.8% (HHV <sup>(4)</sup> )	75.3% (LHV <sup>(5)</sup> )
Optimum efficiency <sup>(6)</sup>	77.2%	
Burn rate	1.2 lb/h to 5.0 lb/h (0.5 kg/h to 2.3 kg/h)	
Average particulate emissions rate <sup>(7)</sup>	2.9 g/h (EPA / CSA B415.1-10)	
Average CO <sup>(8)</sup>	41.2 g/h	
Average electrical power consumption <sup>(9)</sup>	3.5A (420W) for ignition cycle 2.3A (276W) min. / 3.1A (372W) max. for continuous operation	

*[\*] Recommended heating area and maximum burn time may vary subject to location in home, chimney draft, heat loss factors, climate, fuel type, feed rate, fuel level, and other variables. The recommended heated area for a given appliance is defined by the manufacturer as its capacity to maintain a minimum acceptable temperature considering that the space configuration and the presence of heat distribution systems have a significant impact in making heat circulation optimum.*

*(†) Grades of pellet fuel are determined by organizations such as Pellet Fuels Institute (PFI), ENplus and CANplus.*

*(1) Values are as measured per test method, except for the recommended heating area, hopper capacity, maximum burn time and maximum heat input rate. Results may vary depending on pellet quality, density, length, and diameter.*

*(2) Based on the maximum burn-rate and a dry energy value of pellet at 8,600 BTU/lb.*

*(3) As measured per CSA B415.1-10 stack loss method.*

*(4) Higher Heating Value of the fuel.*

*(5) Lower Heating Value of the fuel.*

*(6) Optimum overall efficiency at a specific burn rate (LHV).*

*(7) This appliance is officially tested and certified by an independent agency.*

*(8) Carbon monoxide.*

*(9) Unless stated otherwise, measures were taken directly at the main power source and include all electrical components present in the appliance.*

## 1.2 General Features

Recommended chimney diameter	3 po
Flue outlet diameter	3 po (75 mm)
Type of chimney	ULC/ORD-C441, CAN/ULC S609, UL 641 (TYPE L)
Baffle material	Stainless Steel
Approved for alcove installation	Yes
Approved for mobile home installation <sup>‡</sup>	Yes
Shipping weight (without option)	348 lb (158 kg)
Appliance weight (without option)	294 lb (133 kg)
Type of door	Single, glass with cast iron frame
Glass type	Ceramic glass
Blower	Included (up to 176 CFM (0.08 m <sup>3</sup> /s))
Particulate emission standard	EPA / CSA B415.1-10
USA standard (safety)	ASTM E1509 and UL 1482
Canadian standard (safety)	ULC S627
Noise level at 6 feet	Min: 49 dBa (+/- 3 dBa) – Max: 59 dBa (+/- 3 dBa)
Electrical requirements	Voltage and frequency: 120VAC and 60Hz AC Current: 2.3A/120VAC - 3.5A/120VAC
Control board fuses	Main: 7.5A-250V fast-blow fuse Convection blower: 5A-250V fast-blow fuse Combustion blower: 3A-250V fast-blow fuse Exhaust blower: 3A-250V fast-blow fuse Auger motor #1: 3A-250V fast-blow fuse Auger motor #2: 3A-250V fast-blow fuse Igniter: 5A-250V fast-blow fuse

<sup>‡</sup> Mobile home (Canada) or manufactured home (USA): The US department of Housing and Urban Development describes “manufactured homes” better known as “mobile homes” as followed; buildings built on fixed wheels and those transported on temporary wheels/axles and set on a permanent foundation. In Canada, a mobile home is a dwelling for which the manufacture and assembly of each component is completed or substantially completed prior to being moved to a site for installation on a foundation and connection to service facilities and which conforms to the CAN/CSA-Z240 MH standard.

### 1.3 Overall Exterior Dimensions

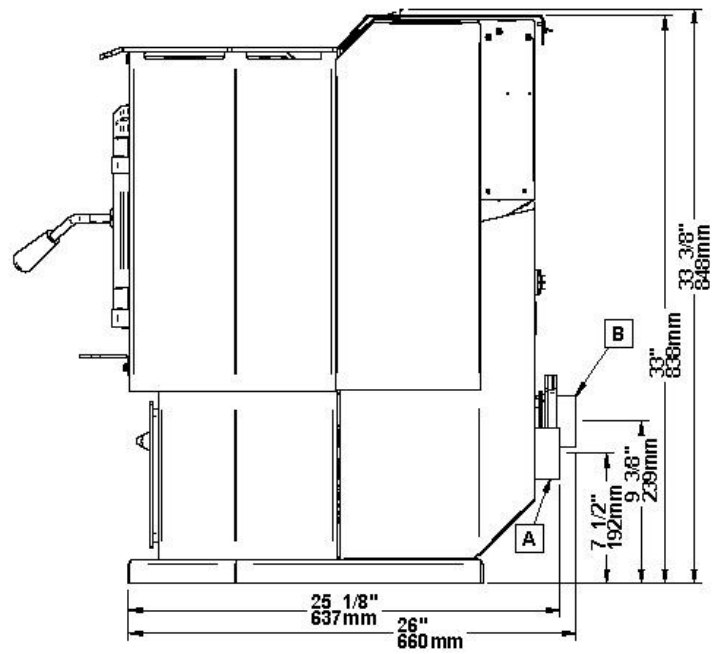
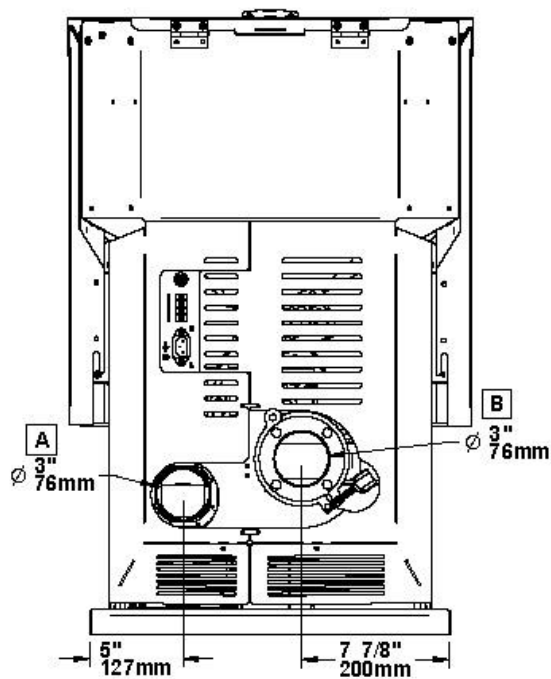
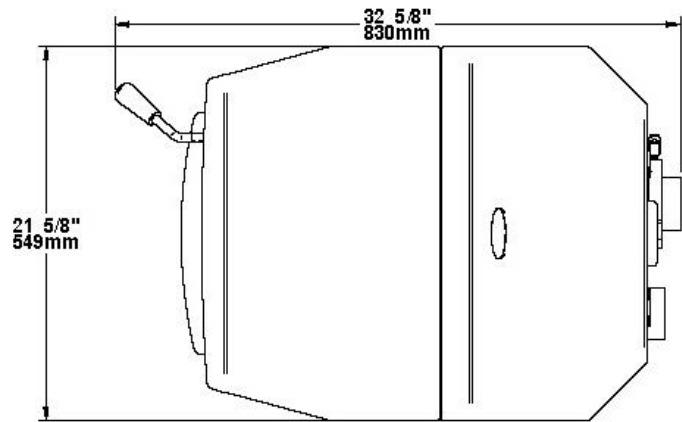
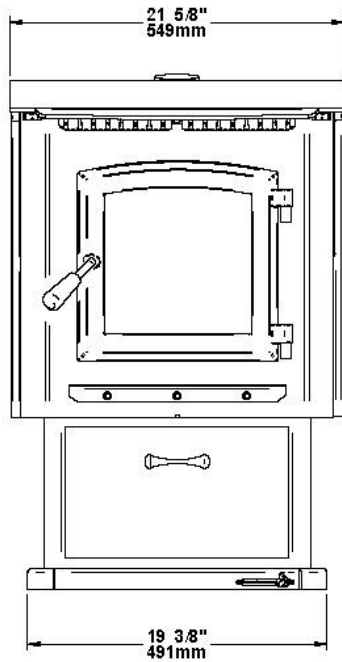

A	FRESH AIR INTAKE
B	FLUE OUTLET

## **PART A – INSTALLATION**

### **2 INSTALLATION SAFETY INFORMATION**

#### **2.1 Warnings and Cautions**

##### **ATTENTION**

THE INFORMATION GIVEN ON THE CERTIFICATION LABEL AFFIXED TO THE STOVE ALWAYS OVERRIDES THE INFORMATION PUBLISHED IN ANY OTHER MEDIA (OWNER'S MANUAL, CATALOGUES, FLYERS, MAGAZINES AND/OR WEB SITES).

##### **CAUTION**

- IF THIS STOVE IS NOT PROPERLY INSTALLED, A HOUSE FIRE MAY RESULT. TO REDUCE THE RISK OF FIRE, FOLLOW THE INSTALLATION INSTRUCTIONS.
- BURNING ANY SOLID FUELS GENERATES CARBON MONOXIDE IN LOW CONCENTRATION. THIS GAS IS EVACUATED BY THE EXHAUST VENTING SYSTEM. IN HIGHER CONCENTRATIONS, CARBON MONOXIDE IS TOXIC AND MAY CAUSE DEATH. TO PREVENT THIS, ENSURE THAT YOUR EXHAUST VENTING SYSTEM IS AIRTIGHT.

##### **WARNING – APPLIANCE LOCATION**

- WHEN LOCATING YOUR APPLIANCE, MAKE SURE THE VENT WILL NOT INTERFERE WITH ANY TRUSS, ROOF BEAMS, WALL STUDS, WATER PIPES OR ELECTRICAL WIRING. IT MAY BE EASIER TO RELOCATE APPLIANCE THAN TO REWORK THE BUILDING STRUCTURE.
- THIS STOVE IS NOT RECOMMENDED TO BE INSTALLED IN A BEDROOM.

##### **WARNING – VENTING SYSTEM**

- CONNECT THIS STOVE ONLY TO A LISTED PELLET EXHAUST VENTING SYSTEM FOR USE WITH SOLID FUEL OR TO A LINED CHIMNEY CONFORMING TO NATIONAL AND LOCAL BUILDING CODES.
- DO NOT INSTALL A FLUE DAMPER IN THE EXHAUST VENTING SYSTEM OF THIS UNIT.
- DO NOT CONNECT THIS STOVE TO ANY OTHER EXISTING VENTING SYSTEM SERVING ANOTHER APPLIANCE.
- DO NOT CONNECT TO OR USE IN CONJUNCTION WITH ANY AIR DISTRIBUTION DUCTWORK.
- THE VENTING SYSTEM MUST BE COMPLETELY AIRTIGHT AND PROPERLY INSTALLED. ALL VENT CONNECTOR JOINTS MUST BE SEALED AND FASTENED IN ACCORDANCE WITH THE PELLET VENT MANUFACTURER'S INSTRUCTIONS TO ENSURE CONSISTENT PERFORMANCE AND AVOID SMOKE AND ASH SPILLAGE.
- THE VENTING SYSTEM SHOULD BE CHECKED, AT LEAST TWICE A YEAR FOR ANY BUILDUP OF SOOT OR CREOSOTE.

## **WARNING – APPLIANCE INSTALLATION**

- PROFESSIONAL INSTALLATION IS HIGHLY RECOMMENDED.
- YOU MAY NEED TO OBTAIN A BUILDING PERMIT FOR THE INSTALLATION OF THIS STOVE AND ITS VENTING SYSTEM. CONSULT YOUR MUNICIPAL BUILDING DEPARTMENT OR FIRE DEPARTMENT BEFORE INSTALLATION TO DETERMINE THE NEED TO OBTAIN ONE. WE RECOMMEND THAT YOU ALSO INFORM YOUR HOME INSURANCE COMPANY TO FIND OUT IF THE INSTALLATION WILL AFFECT YOUR POLICY.
- THIS STOVE MUST BE CONNECTED TO A STANDARD 120V, 60 HZ GROUNDED ELECTRICAL OUTLET. DO NOT USE AN ADAPTER PLUG OR SEVER THE GROUNDING PLUG. DO NOT ROUTE THE ELECTRICAL CORD UNDERNEATH, IN FRONT OR OVER THE STOVE.
- THIS STOVE IS MOBILE HOME APPROVED AND REQUIRES INSTALLATION OF A FRESH AIR KIT, SOLD SEPARATELY. THE STOVE MUST BE ATTACHED TO THE STRUCTURE OF THE MOBILE HOME AND THE STRUCTURAL INTEGRITY OF THE MOBILE HOME FLOOR, WALL, AND CEILING/ROOF MUST BE MAINTAINED. DO NOT INSTALL IN A SLEEPING ROOM.
- IF REQUIRED, A FRESH AIR KIT CAN BE INSTALLED TO SUPPLY COMBUSTION AIR TO THE ROOM OR SPACE (SEE APPENDIX E: *COMBUSTION AIR SUPPLY*).
- STOVE BUILDER INTERNATIONAL INC. (SBI) GRANTS NO WARRANTY, IMPLIED OR STATED, FOR THE POOR INSTALLATION OR LACK OF MAINTENANCE OF YOUR STOVE AND ASSUMES NO RESPONSIBILITY OF ANY CONSEQUENTIAL DAMAGES.

## **WARNING – APPLIANCE OPERATION AND MAINTENANCE**

- THIS STOVE HAS BEEN DEVELOPED AND BUILT FOR RESIDENTIAL SUPPLEMENTARY HEAT SOURCE. COMMERCIAL AND INDUSTRIAL USE IS PROHIBITED AND WILL VOID THE WARRANTY.
- NEVER BLOCK ANY LOUVERS OF THE STOVE.
- MIXING OF APPLIANCE COMPONENTS FROM DIFFERENT SOURCES OR MODIFYING COMPONENTS IS PROHIBITED AND WILL VOID THE WARRANTY.
- ANY MODIFICATION OF THE STOVE THAT HAS NOT BEEN APPROVED IN WRITING BY THE TESTING AUTHORITY IS PROHIBITED AND VIOLATES CSA B365 (CANADA), AND ANSI NFPA 211 (USA).

## 2.2 Regulations Covering Pellet Stove Installation

When installed and operated as described in these instructions, this pellet stove is suitable for use as a freestanding heater in residential installations.

In Canada, the CSA B365 Installation Code for Solid Fuel Burning Appliances and Equipment and the CSA C22.1 Canadian National Electrical Code are to be followed in the absence of local code requirements. In the USA, the ANSI NFPA 211 Standard for Chimneys, Fireplaces, Vents and Solid Fuel-Burning Appliances and the ANSI NFPA 70 National Electrical Code are to be followed in the absence of local code requirements.

This stove must be connected to a pellet vent system complying with the requirements for Pellet Vent in the standards UL 103, UL 641, ULC S629M, CAN/ULC S609 and ULC/ORD C441 or to a code-approved masonry chimney with a stainless steel flue liner.

## 2.3 Before Operating Your Stove

Some minor installation and adjustment are required prior to use:

- LCD support can be installed at the back of the stove, on the right or the left; (see **Appendix B**)
- The handle and door must be adjusted; (see **section 8.1.10 Door Adjustment**)
- The stove must be leveled using threaded legs;
- Make sure the back draft shutter (**F**) from the fresh air intake works freely.

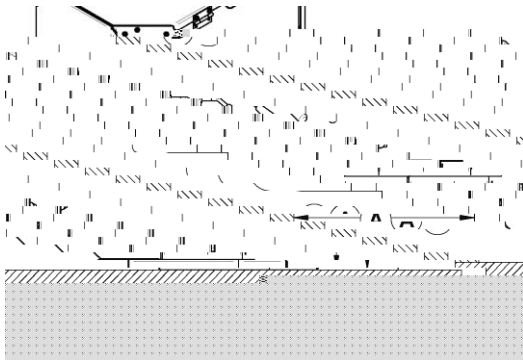

- Make sure to remove all tools or accessories that have been inserted in the stove for transportation purposes (see following illustration.)

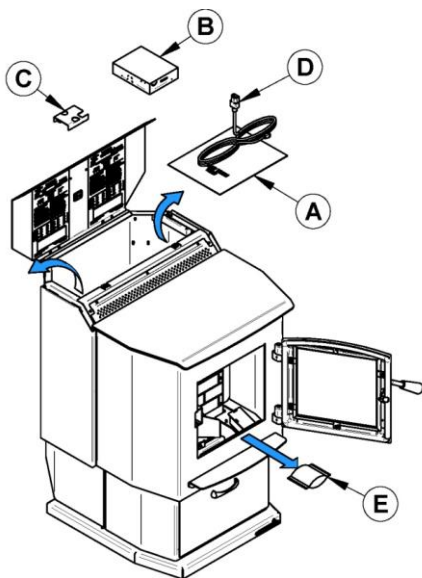

A	Installation and Operation manual
B	Touch Screen
C	Touch Screen support
D	Power cord
E	Dessicant (moisture absorbant)

### 3 CLEARANCES TO COMBUSTIBLE MATERIALS

The clearances shown in this section have been determined by tests according to procedures set out in safety standards ULC S627 (Canada), ASTM E1509 (U.S.A) and UL1482 (USA). When the pellet stove is installed so that its surfaces are at, or beyond, the minimum clearances specified, combustible surfaces will not overheat under normal and even abnormal operating conditions.

#### WARNING

- NO PART OF THE STOVE MAY BE LOCATED CLOSER TO COMBUSTIBLES THAN THE MINIMUM CLEARANCES SPECIFIED ON THE CERTIFICATION LABEL.
- NO PART OF THE PELLET VENT SYSTEM MAY BE LOCATED CLOSER TO COMBUSTIBLES THAN THE MINIMUM CLEARANCES SPECIFIED BY THE VENT MANUFACTURER.

#### CAUTION

- DO NOT USE MAKESHIFT MATERIALS OR MAKE ANY COMPROMISES WHEN INSTALLING THIS STOVE.

#### 3.1 Certification Label Location

Since the information given on the certification label affixed to the stove always overrides the information published in any other media (owner's manual, catalogues, flyers, magazines and/or web sites), it is important to refer to it in order to have a safe and compliant installation. In addition, you will find important information about your stove (model, serial number, etc.). You will find the certification label on the inner side of the hopper lid of the stove.

#### 3.2 Clearances to combustibles materials, walls and ceiling

The distances listed in this table refer to the distances obtained during regular testing. However, it is possible to install the stove at reduced clearances by installing either a *certified heat shield system* (AC02710) or a side clearance reduction kit (AC02733), sold separately.

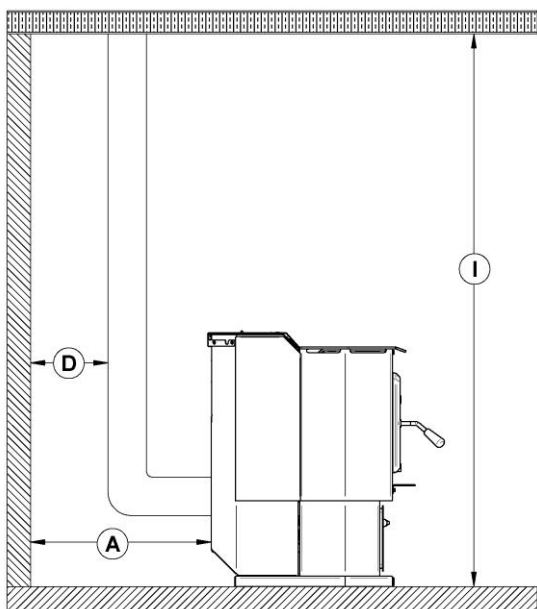

<b>MINIMUM CLEARANCES</b>		
<b>LETTER</b>	<b>CANADA</b>	<b>USA</b>
<b>A*</b>	3" (76 mm)	3" (76 mm)
<b>D</b>	Note 1	Note 1
<b>I**</b>	48" (1 220 mm)	48" (1 220 mm)

\* From the rear panel

\*\* Measured from the platform on which the product is installed.

<b>RECOMMENDED CLEARANCES<sup>2</sup></b>		
<b>LETTER</b>	<b>CANADA</b>	<b>USA</b>
<b>A*</b>	12" (305 mm)	12" (305 mm)

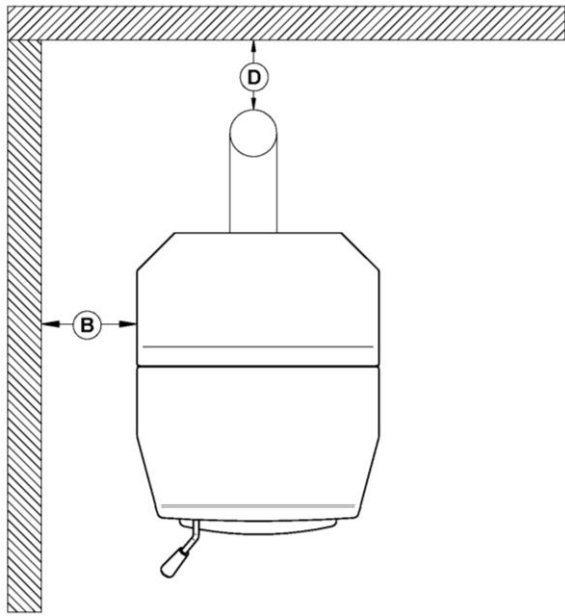

<b>MINIMUM CLEARANCES</b>		
<b>LETTER</b>	<b>CANADA</b>	<b>USA</b>
<b>B</b>	17" (432 mm)	17" (432 mm)
<b>B<sup>3</sup></b>	8" (203 mm)	8" (203 mm)
<b>B<sup>4</sup></b>	3" (76 mm)	3" (76 mm)
<b>D</b>	Note 1	Note 1

<b>RECOMMENDED CLEARANCES<sup>2</sup></b>		
<b>LETTER</b>	<b>CANADA</b>	<b>USA</b>
<b>B</b>	24" (610 mm)	24" (610 mm)

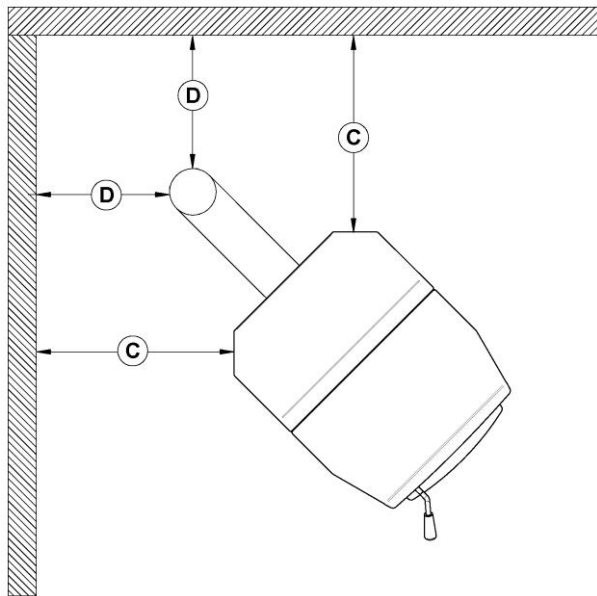

<b>MINIMUM CLEARANCES</b>		
<b>LETTER</b>	<b>CANADA</b>	<b>USA</b>
<b>C</b>	4" (102 mm)	4" (102 mm)
<b>C<sup>5</sup></b>	3" (76 mm)	3" (76 mm)
<b>D</b>	Note 1	Note 1

<b>RECOMMENDED CLEARANCES<sup>2</sup></b>		
<b>LETTER</b>	<b>CANADA</b>	<b>USA</b>
<b>C</b>	12" (305 mm)	12" (305 mm)

- 1: Refer to the exhaust venting system manufacturer's instructions for clearances to combustibles materials.
- 2: Clearances are to facilitate maintenance.
- 3: Clearances to adjacent wall reduced by using the side clearance reduction kit (AC02733), sold separately.
- 4: Clearances to adjacent wall reduced by using the certified heat shield system (AC02710), sold separately.
- 5: Clearances to adjacent wall reduced by using either the side clearance reduction kit (AC02733) or the certified heat shield system (AC02710), both sold separately.

### NOTE

**THESE CLEARANCES ARE ALSO VALID FOR AN ALCOVE INSTALLATION. HOWEVER, IF THE STOVE IS INSTALLED IN AN ALCOVE, TO PERFORM MAINTENANCE, YOU SHOULD EXPECT TO MOVE THE APPLIANCE TO GET TO THE MAINTENANCE ACCESS DOORS AND COMPONENTS.**

### 3.3 Floor Protection

For floor protection clearances refer to the following figure and table.

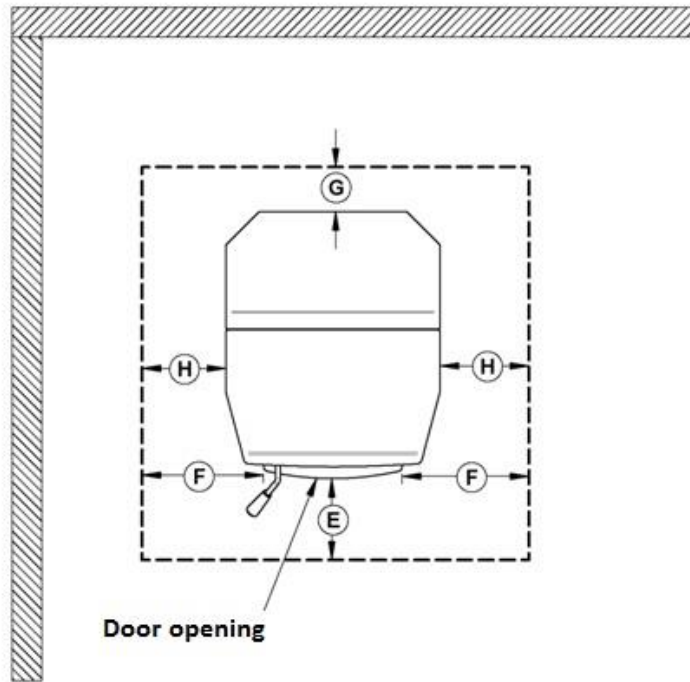

LETTER	CANADA	USA
E	18" (460 mm)** From door opening	6" (155 mm) From door opening
F	N/A (USA only)	6" (155 mm) From door opening
G	8" (205 mm)	N/A (Canada only)
H	8" (205 mm)	N/A (Canada only)

#### CAUTION

**THE STOVE MUST BE PLACED ON A CONTINUOUS (GROUTED JOINTS) NONCOMBUSTIBLE MATERIAL SUCH AS CERAMIC TILE\*, CEMENT BOARD, BRICK, MILLBOARD OR EQUIVALENT, OR ANY OTHER APPROVED OR LISTED MATERIAL SUITED FOR FLOOR PROTECTION.**

*\*Any type of tile will require a continuous non combustible sheet beneath to prevent the possibility of embers falling through to the combustible floor if cracks or separation should occur in the finished surface, this would include floor protection for built-in raised hearths. Check local codes for approved alternatives.*

*\*\*In Canada, you may reduce to the U.S. floor protection requirements (E) ONLY if the following actions are respected: Allow for the appliance to shut-down and fires to be extinguish. Once completely cool and all blowers have stopped you may proceed with opening the firebox or ash door.*

## 4 VENTING SYSTEM

### 4.1 General

Even though the chimney draft is mechanical, a suitable venting system will ensure a natural draft which will prevent smoke spillage in your home if a power outage occurs. Moreover, a suitable venting system configuration will help getting the best efficiency out of your stove when installed in accordance with the required EVL (see **Section 4.3 Equivalent Vent Length (EVL)**).

Even the best stove will not function safely and efficiently as intended if it is not connected to a suitable venting system.

### 4.2 Recommendations

In Canada, we recommend that you use a listed pellet vent that meets the CAN/ULC S609 or ULC/ORD C441 Standard. A pellet vent listed to ULC S629M is also suitable for installation with this stove.

For the United States, we recommend that you use a listed pellet vent that meets the UL 641 Standard. A pellet vent listed to UL 103 is also suitable for installation with this stove.

This stove can be vented in an existing factory-built or masonry chimney with the addition of a stainless steel liner, provided the chimney is more than 4" in diameter. The liner should be listed and should meet the ULC S635 CAN/ULC S640 standard in Canada and the UL 1777 standard in the USA. Refer to the instructions provided by the vent manufacturer, especially when passing through a wall, ceiling or roof.

### 4.3 Equivalent Vent Length (EVL)

#### 4.3.1 Recommended Exhaust Venting Diameter

Recommended venting system inner pipe diameter is 3". Use a 4" pipe if you have more than 15 feet of Equivalent Vent Length (EVL).

To calculate the Equivalent Vent Length of your installation, use the following conversions:

Qty	Type of pipe	Equivalent Length (EVL)
1	90° elbow or "T"	5 feet
1	45° elbow	3 feet
1 foot	Horizontal pipe run	1 foot
1 foot	Vertical pipe run	0.5 foot

#### CAUTION

- **HORIZONTAL RUNS SHALL NOT EXCEED 9 FEET.**
- **NEVER EXCEED 30 FEET OF EVL.**

Here is an example to help you calculate Equivalent Vent Length. On the following figure the EVL can be calculated like this:

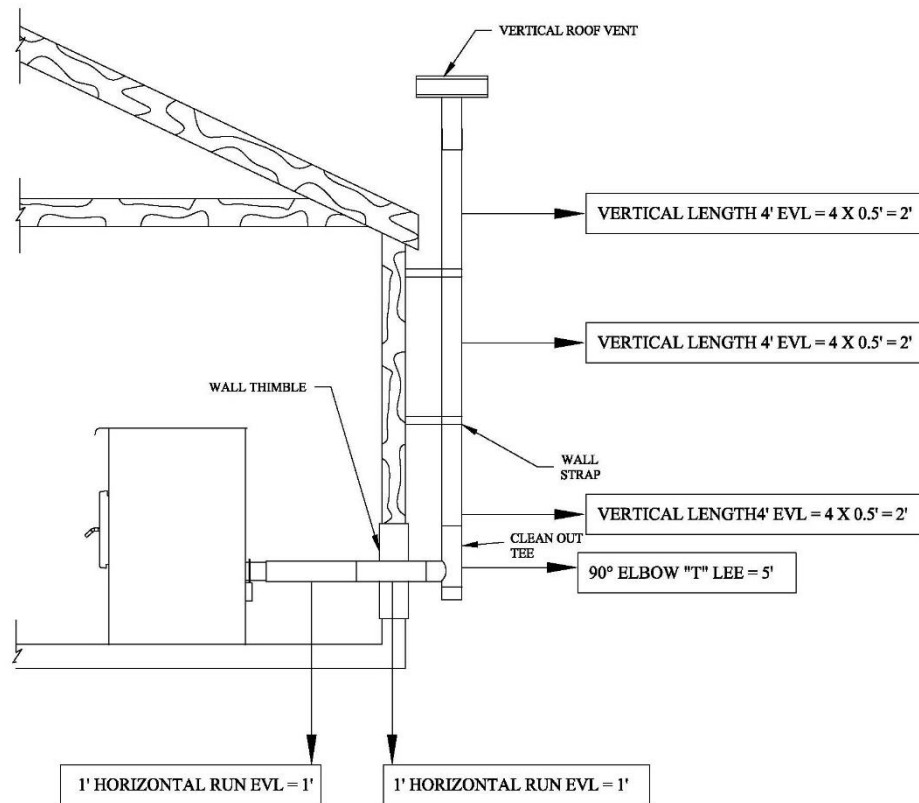

- 2 horizontal run of 1' =  $(2 \times 1') \times 1' = 2'$  of EVL
- 1 elbow 90° or "Tee" = 5' of EVL
- 3 vertical length of 4' =  $(3 \times 4') \times 0.5' = 6'$  of EVL
- Total EVL =  $(2' + 5' + 6') = 13'$

Since the total EVL is less than 15 feet, the recommended exhaust venting diameter is 3".

#### NOTE

**DO NOT INCLUDE THE EXTERIOR WALL TERMINATION IN THE EVL CALCULATION (45° ELBOW AND TERMINATION COLLAR).**

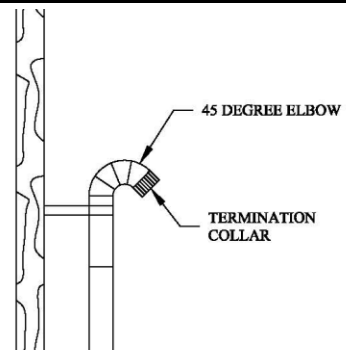

### 4.3.2 Installation compliance

To determine if your installation is compliant, the exhaust venting system must end within the grid on the venting system chart. The previous installation has 2 feet of horizontal run and 12 feet of vertical run. It is thus standard since the venting system ends in the gridded area.

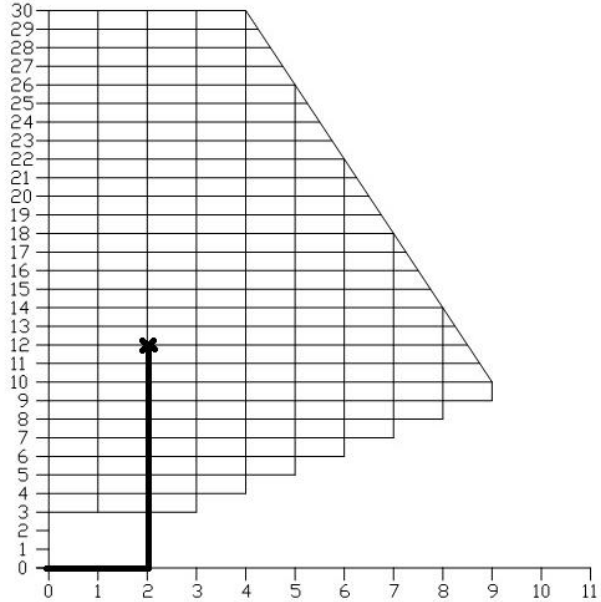

### WARNING

**TO REDUCE THE RISK OF SMOKE SPILLAGE THERE SHOULD ALWAYS BE AT LEAST ONE FOOT OF VERTICAL RISE FOR EACH FOOT OF HORIZONTAL RUN. IN ALL CASES, AT LEAST 3 FEET OF VERTICAL RISE IS NEEDED.**

### 4.4 Termination Location

Termination should not be located so that hot exhaust gases can be a hazard. They can reach temperatures of 500°F (260°C) and cause serious burns.

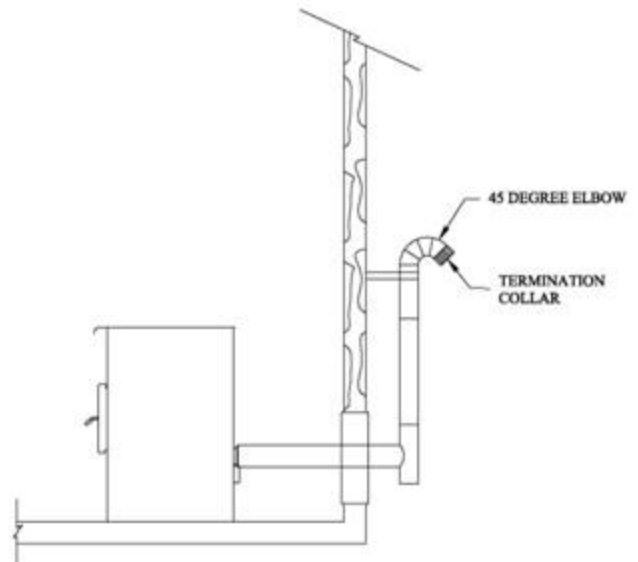

### CAUTION

**TERMINATION COLLAR (SPARK ARRESTER) IS MANDATORY.**

#### 4.4.1 Permitted Termination Location

Refer to NFPA 211 (USA) or CSA B365 (Canada) for rules for the distance of exit terminal from windows and openings. The exit terminal of a mechanical draft system, other than a direct vent appliance shall be located in accordance with the following.

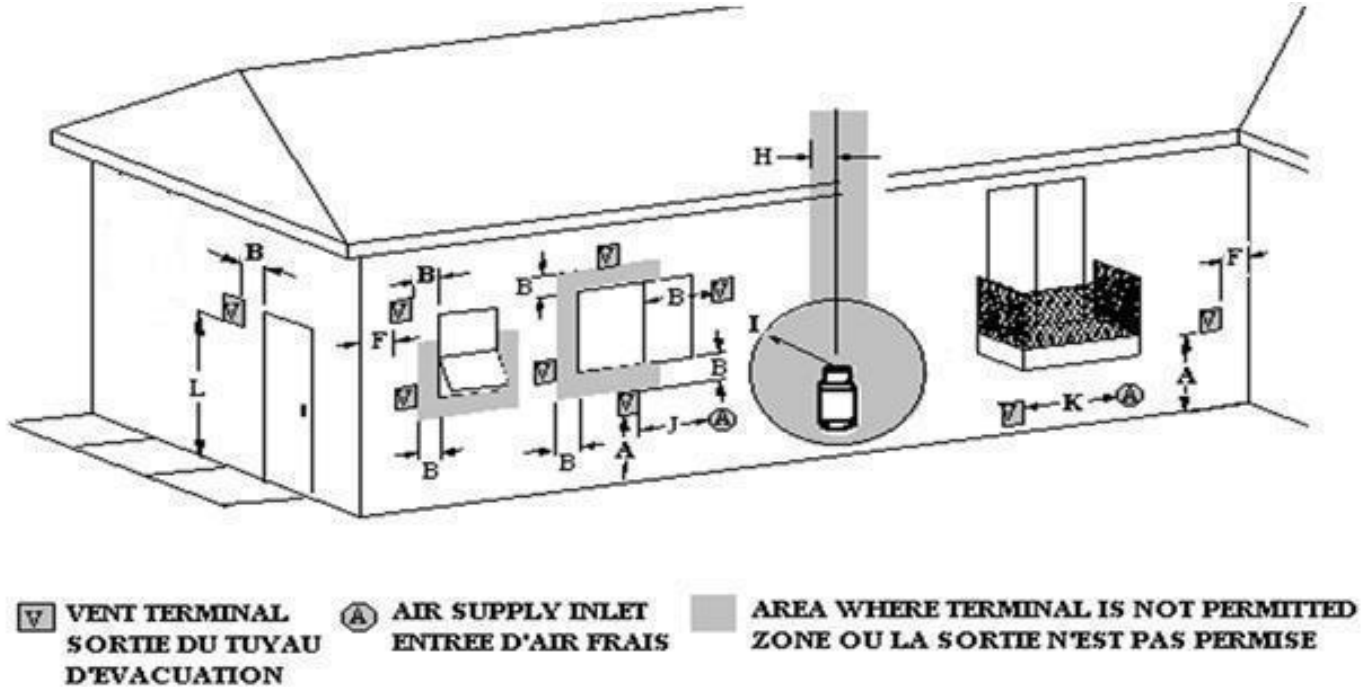

#### Canada:

Letter	Min. clearances	Description
A	12" (30 cm)	Clearances above grade level or any adjacent surface that might support snow, ice, or debris.
B	39" (100 cm)	Clearance to window or door that may be opened.
F	39" (100 cm)	Clearance to corner or adjacent wall.
H	39" (100 cm)	Not to be installed above a meter/regulator assembly within 39" (100 cm) horizontally from the vertical center-line of the regulator and for 15' vertically.
I	72" (183 cm)	Clearance to gas service regulator vent outlet or within 39" (100 cm) of an oil tank vent or an oil tank fill inlet.
J	39" (100 cm)	Clearance to the combustion air inlet to any other appliance.
K	72" (183 cm)	Clearance to a mechanical air supply inlet.
L	84" (213 cm)	Clearance above paved side-walk or a paved driveway located on public property.
	39" (100 cm)	Clearance to property boundary.
		A vent shall not terminate underneath a veranda, porch, or deck.

## **United States:**

- Not Less than 36" (91 cm) above any forced air inlet located within 120" (305 cm);
- Not Less than 48" (122 cm) below and horizontally from, or 12" (30 cm) above, any door, window or gravity air inlet into any building;
- Not Less than 24" (61 cm) from an adjacent building and not less than 84" (213 cm) above grade when located adjacent to a public walkway;
- Cannot be located less than 12" (30 cm) above grade;
- Cannot be located above a gas meter/regulator within 36" (91cm) horizontally of the vertical center line of the regulator;
- Not within 6 feet (183 cm) of a gas service regulator vent outlet;
- Other restrictions may apply. See NFPA 211 for further information.

### **4.4.1.1 Direct Vent System (2-in-1 Exhaust and fresh air intake)**

**In Canada:** The permitted termination location for a direct vent system are the same than those permitted with a regular pellet vent system.

**In the Unites States:** The permitted termination location for a direct vent system are the same than those permitted with a regular pellet vent system except for the following : The exit terminal shall be located not less than 9" (23 cm) from any opening through which vent gases could enter a building.

## **4.5 Installation Configurations**

### **4.5.1 Installation Warnings, Cautions and Recommendations Reminder**

#### **CAUTION**

- **PROFESSIONNAL INSTALLATION IS HIGHLY RECOMMENDED.**
- **THIS STOVE USES A PRESSURIZED VENTING SYSTEM. ALL VENT CONNECTOR JOINTS MUST BE SEALED AND FASTENED. YOU MAY USE RTV SILICONE (ROOM TEMPERATURE VULCANISATION), METALLIC TAPE, AND A MINIMUM OF THREE SELF-TAPING SCREWS AT ALL JOINT CONNECTIONS TO ENSURE A TIGHT SEAL. CONSULT THE PELLET VENT MANUFACTURER'S INSTRUCTION TO ENSURE PROPER INSTALLATION, CONSISTENT PERFORMANCE, AND TO AVOID SMOKE AND ASH SPILLAGE.**
- **THE CHIMNEY CONNECTOR SHALL NOT PASS THROUGH AN ATTIC OR ROOF SPACE, CLOSET OR SIMILAR CONCEALED SPACE OR FLOORS OR CEILING.**
- **INSTALL VENTING SYSTEM AT CLEARANCES SPECIFIED BY THE VENT MANUFACTURER.**
- **THE USE OF A SPARK ARRESTER AT THE END OF THE TERMINATION IS MANDATORY. IT IS IMPORTANT THAT THE SPARK ARRESTER BE CLEAR OF ANY DEBRIS AT ALL TIME.**

#### 4.5.2 Through Wall Installation (Main Floor or Basement)

### CAUTION

TO REDUCE THE RISK OF SMOKE SPILLAGE THERE SHOULD ALWAYS BE AT LEAST 12" (30 CM) OF VERTICAL RISE FOR EACH FOOT OF HORIZONTAL RUN. IN ALL CASES, AT LEAST 36" (91 CM) OF VERTICAL RISE IS NEEDED BEFORE THE TERMINATION.

### WARNING

TERMINATION OF A SIDE WALL VENT SHOULD BE LOCATED TO AVOID PERSONAL BURN INJURY, FIRE HAZARD AND INTERFERENCE WITH OR DAMAGE TO ADJACENT PROPERTIES. EXHAUST GASES CAN REACH TEMPERATURES OF 500°F (260°C) AND CAUSE SERIOUS BURNS. SEE SECTION 4.4.1 PERMITTED TERMINATION LOCATION.

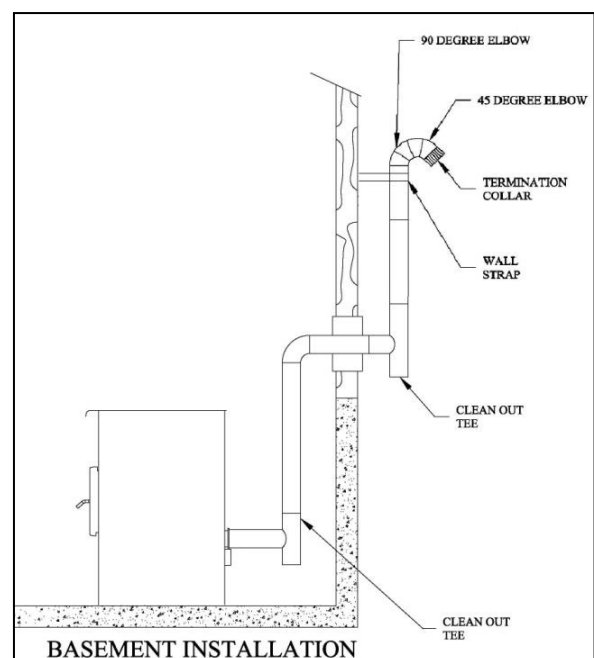
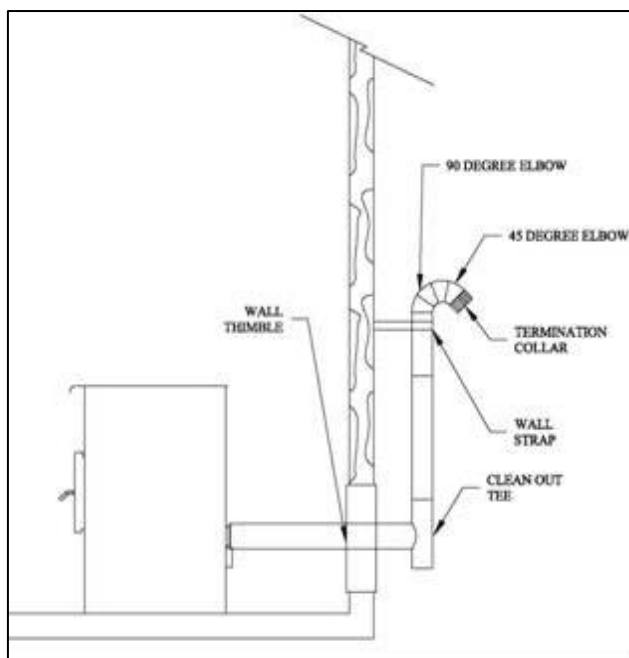

1. Position stove following clearances given in **Section 3, Clearances to Combustible Material** and following vent manufacturer's instructions.
2. Install a stove adapter or a stove adapter tee onto the appliance flue collar.
3. Locate the position of the exhaust pipe in the wall and cut a hole of the appropriate size for vent in the wall.
4. Install wall thimble as per vent manufacturer's instructions.
5. Ensure you install enough horizontal pipe length to exceed the exterior wall of 6 inches. Install a tee section to the pipe passing through the wall.
6. Run the vent vertically up the wall for at least 36". Refer to the vent manufacturer's instructions for clearances to combustible materials and installation of wall bands.

7. Install a 90 degrees elbow facing out from the wall and then attach a 45 degree elbow facing towards the ground. The termination of the vent must include a spark arrester, fastened to the 45 degrees elbow.
8. Sealed outside wall thimbles with high temperature waterproof silicone sealant.

#### 4.5.3 Through Roof Installation

1. Position stove following clearances given in **Section 3.2 Minimum Clearances to Combustibles** and following vent manufacturer's instructions.
2. Install a stove adapter or a stove adapter tee onto the appliance flue collar. If necessary, use a horizontal additional length between the flue outlet and the tee.
3. Drop the plumb line over the center of the tee outlet and mark location on the ceiling.
4. Cut a hole for appropriate ceiling support. Frame rough opening.
5. Install ceiling support and the first vent section as per vent manufacturer's instructions.
6. Install a firestop radiation shield on any subsequent ceiling/floor, except for the attic where an attic insulation shield is required.
7. Run the necessary section of vent vertically so the rain cap exceeds the highest point of the roof at least 24" in United States and at least 36" in Canada.
8. Install roof support.
9. Install roof flashing and rain cap as per manufacturer's instructions. If necessary, install a storm collar.

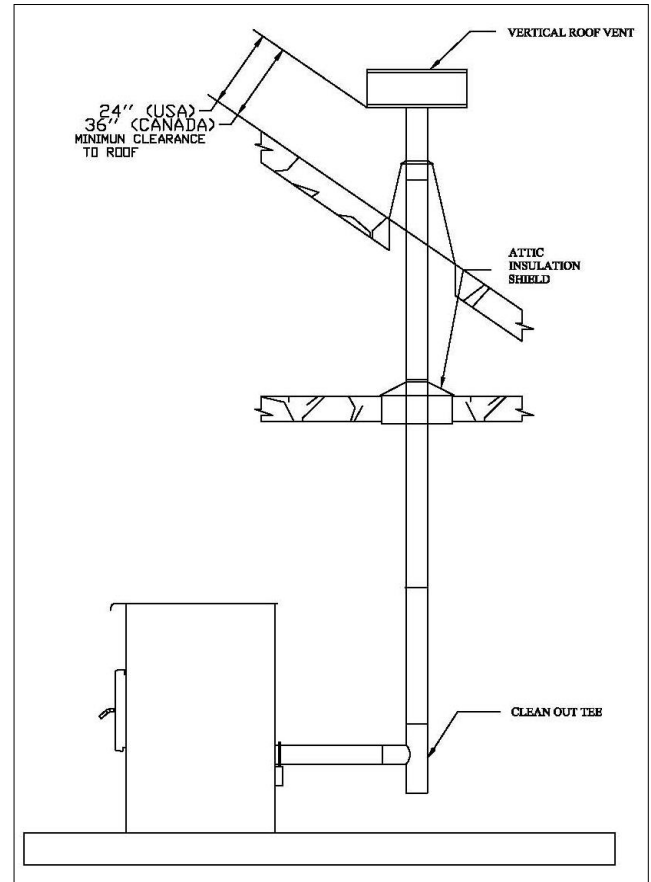

#### 4.5.4 Through a Factory Built Chimney

### NOTE

**BEFORE INSTALLATION, THE CHIMNEY MUST BE CLEANED AND INSPECTED BY A QUALIFIED CHIMNEY SWEEP OR INSTALLER.**

1. Position stove following clearances given in **Section 3.2 *Minimum Clearances to Combustibles*** and following vent manufacturer's instructions.
2. Install a stove adapter or a stove adapter tee onto the appliance flue collar. If necessary, use a horizontal additional length between the flue outlet and the tee.
3. Use a proper chimney adaptor for your installation.
4. Run the number of sections of vent necessary to go through the chimney adaptor into the chimney.
5. Connect the vent to a stainless steel 4" liner according to the vent manufacturer's instruction.
6. Install roof flashing and rain cap as per manufacturer's instructions. If necessary, install and seal a storm collar.

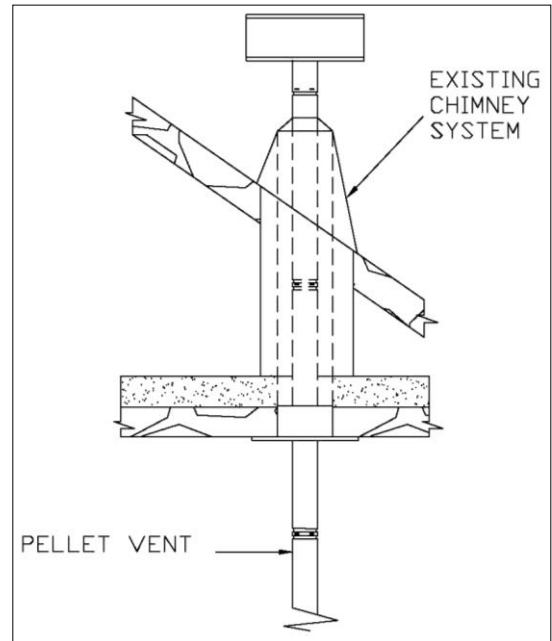

### WARNING

**IN THE U.S., THE USE OF A STAINLESS STEEL LINER IS MANDATORY. IN CANADA, IT IS NOT MANDATORY BUT IS STRONGLY RECOMMENDED.**

### NOTE

**VENTING DIRECTLY IN AN OVERSIZED CHIMNEY AND OMITTING THE USE OF A STAINLESS STEEL LINER CAN AFFECT CHIMNEY DRAFT AND DECREASE STOVE PERFORMANCES.**

#### 4.5.5 Through an Existing Masonry Fireplace

1. Position stove, following clearances shown in **Section 3.2 Minimum Clearances to Combustibles** and following vent manufacturer's instructions.
2. Build and Install a blocking plate inside the chimney to seal the fireplace damper. Stainless steel plate and screws are recommended. Cut a hole for the exhaust pipe. If needed, cut a second hole for the air intake pipe (see **Appendix E**).
3. Attach a section of pipe and clean out tee to the flue outlet, making sure the clean out tee is centered in the chimney flue area.
4. Install a vented flashing at the top of the fireplace chimney. Stainless steel plate and screws are recommended. Cut a hole for the vent pipe. If needed, cut a second hole for the air intake pipe. Seal all joints with high temperature waterproof silicone sealant to prevent water leakage.
5. Seal and install vertical roof vent. If required, seal and install a storm collar.

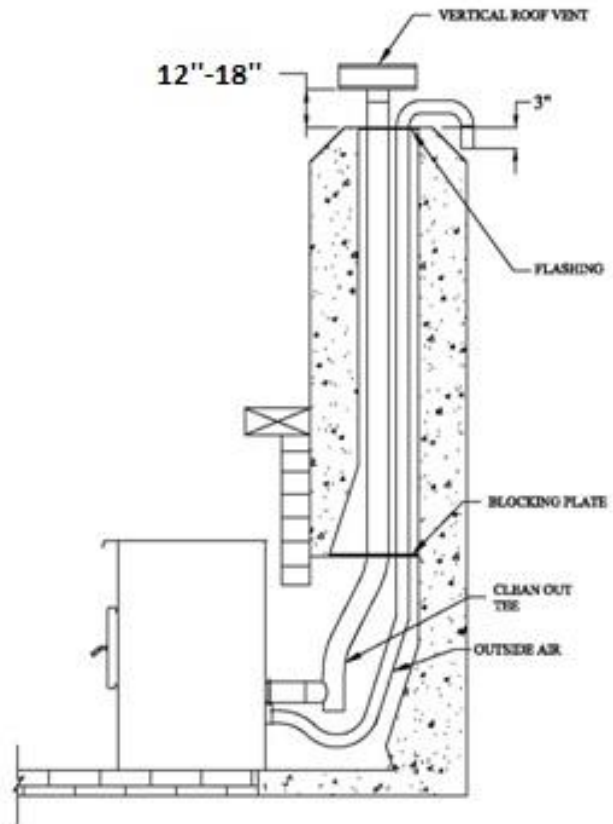

#### NOTE

- **THE STRUCTURAL CONDITION OF THE MASONRY CHIMNEY MUST FIRST BE INSPECTED BY A QUALIFIED CHIMNEY SWEEP OR INSTALLER.**
- **YOU WILL NEED A PIPE LENGTH EQUAL TO THE CHIMNEY HEIGHT FROM THE HEARTH. IF OUTSIDE COMBUSTION AIR IS TO BE USED, YOU WILL NEED A PIPE LENGTH SUPERIOR FROM 12 TO 18 INCHES (30 TO 46 CM) OF THE CHIMNEY HEIGHT TO ENSURE A PROPER STOVE BEHAVIOUR.**

#### 4.5.6 Through an Existing Masonry Chimney

1. Position stove following clearances shown in **Section 3.2 Minimum Clearances to Combustibles** and following vent manufacturer's instructions.

2. Mark the center of the hole where the vent pipe will go through the masonry chimney.

3. It is necessary to make a hole in the masonry with a one-inch diameter greater than the diameter of the vent pipe used.

4. Install the cleanout tee at the bottom of the vertical vent system and lower it down the chimney until the center branch of the tee is aligned with the hole in the masonry.

5. Connect the horizontal vent pipe to the cleanout tee by pushing it through the hole in the masonry.

6. If desired, once the horizontal pipe is in place, the space between the pipe and masonry may be filled with high-temperature grout.

7. Install a vented flashing at the top of the masonry chimney. Stainless steel plate and screws are recommended. Cut a hole for the vent pipe. If needed, cut a second hole for the air intake pipe. Seal all joints with high temperature waterproof silicone sealant to prevent water leakage.

8. Install and seal flashing with high temperature waterproof silicone sealant.

9. Seal and install vertical roof vent. If required, seal and install a storm collar.

10. If desired, install a trim collar and use an additional horizontal vent pipe length, if required, to connect the stove to the chimney.

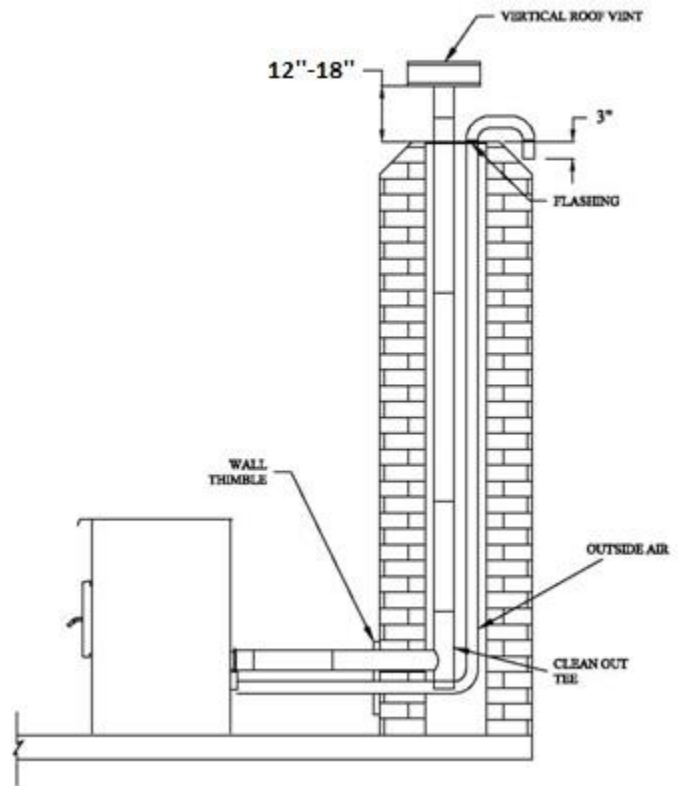

## **PART B - OPERATION**

### **5 GENERAL INFORMATION**

#### **5.1 Operation Warnings, Cautions and Recommendations**

##### **WARNING – APPLIANCE INSTALLATION**

- IT IS HIGHLY RECOMMENDED THAT THE USER BUYS THIS PRODUCT FROM A RETAILER WHO CAN PROVIDE INSTALLATION AND MAINTENANCE ADVICE.
- THIS STOVE MUST SERVE AS A SUPPLEMENTARY HEAT SOURCE. AN ALTERNATIVE HEAT SOURCE SHOULD BE AVAILABLE IN THE HOME IF NEEDED. THE MANUFACTURER CANNOT BE HELD RESPONSIBLE FOR ADDITIONAL HEATING COSTS ASSOCIATED WITH THE USE OF AN ALTERNATIVE HEAT SOURCE.
- STOVE BUILDER INTERNATIONAL INC. GRANTS NO WARRANTY, IMPLIED OR STATED, FOR IMPROPER INSTALLATION OR LACK OF MAINTENANCE OF YOUR STOVE, AND ASSUMES NO RESPONSIBILITY OF ANY CONSEQUENTIAL DAMAGES.

##### **WARNING – APPLIANCE OPERATION**

- HOT WHILE IN OPERATION, KEEP CHILDREN, CLOTHING AND FURNITURE AWAY. CONTACT MAY CAUSE SKIN BURNS. GLOVES MAY BE NEEDED FOR STOVE OPERATION.
- USING A STOVE WITH CRACKED OR BROKEN COMPONENTS, SUCH AS GLASS OR BAFFLE MAY PRODUCE AN UNSAFE CONDITION AND MAY DAMAGE THE STOVE.
- DO NOT STORE FUEL WITHIN STOVE MINIMUM CLEARANCES TO COMBUSTIBLE.
- IT IS RECOMMENDED TO UNPLUG THE STOVE WHEN IT'S NOT IN USE FOR PROLONGED AMOUNT OF TIME (I.E. DURING SUMMER). SENSORS ON THE STOVE ARE ACTIVATED BY HEAT AND COULD ACTIVATE THE FANS EVEN IF THE STOVE IS NOT IN FUNCTION.
- THIS STOVE IS DESIGNED AND TESTED TO BURN ONLY WOOD PELLETS. ANY OTHER TYPE OF FUEL BURNED IN THIS HEATER WILL VOID THE WARRANTY.
- OPERATING YOUR STOVE AT THE MAXIMUM SETTING DURING A LONG PERIOD OF TIME MAY REDUCE THE STOVE AND ITS COMPONENTS LIFE EXPECTANCY.
- THE STOVE WILL NOT OPERATE USING NATURAL DRAFT OR WITHOUT A POWER SOURCE TO ACTIVATE THE BLOWER SYSTEMS AND FUEL FEED SYSTEM.
- THIS STOVE IS DESIGNED TO PROVIDE THE OPTIMUM PROPORTIONS OF FUEL AND AIR TO THE FIRE IN ORDER TO BURN FREE OF SMOKE AND SOOT. ANY BLOCKAGE OF THE AIR SUPPLY TO OR FROM THE STOVE WILL SERIOUSLY DECREASE ITS PERFORMANCE AND WILL BE EVIDENT BY A SMOKING EXHAUST, A SOOT BUILDUP ON THE WINDOW AND ON OUTSIDE WALLS. FOR BEST OPERATION, THE ASH CONTENT OF THE PELLET FUEL SHOULD BE LESS THAN 1% AND THE CALORIFIC VALUE APPROXIMATELY 8,500 BTU/LB. OTHERS FUELS WITH A HIGH ASH CONTENT WILL REQUIRE A HIGHER LEVEL OF MAINTENANCE AND CLEANING.
- DO NOT OPERATE THE STOVE IF THE FLAME BECOMES DARK AND SOOTY OR IF THE BURN POT OVERFILLS WITH PELLETS. TURN THE STOVE OFF, INSPECT IT, AND CALL YOUR DEALER.

## WARNING – APPLIANCE OPERATION

- THE VIEWING DOOR MUST BE CLOSED AND LATCHED AT ALL TIMES DURING OPERATION. THE ASH DRAWER ACCESS PANEL MUST ALSO BE CLOSED DURING OPERATION.
- DO NOT OPERATE THE STOVE IF YOU SMELL OR SEE SMOKE. TURN IT OFF, MONITOR IT AND CALL YOUR DEALER IF NECESSARY. DO NOT UNPLUG IT. NEVER OPEN THE DOOR.
- IF YOU NOTICE A SMOLDERING FIRE (BURNPOT FULL BUT NO VISIBLE FLAME) AND A HEAVY SMOKE BUILDUP IN FIREBOX, IMMEDIATELY TURN OFF THE STOVE, BUT DO NOT UNPLUG IT. DO NOT OPEN THE DOOR OR THE HOPPER LID. MAKE SURE THAT THE FRESH AIR INTAKE SHUTTER WORKS FREELY. WAIT UNTIL SMOKE INSIDE THE FIREBOX CLEARS AND BLOWERS SHUT DOWN. DO AS INSTRUCTED IN “EVERYDAY STARTUP” THEN ATTEMPT TO RESTART THE STOVE. IF THE PROBLEM PERSISTS, CONTACT YOUR DEALER. NOTE THAT SMOKE BUILD-UP DURING IGNITION MAY OCCUR. SMOKE CAN ACCUMULATE IN THE FIREBOX FOR A FEW SECONDS JUST BEFORE THE IGNITOR IS HOT ENOUGH TO FIRE-UP THE PELLETS IN THE BURN POT. THIS IS NORMAL. AS SOON AS THERE IS FIRE IN THE BURN POT, SMOKE WILL DISAPPEAR.
- DO NOT UNPLUG THE STOVE IF YOU SUSPECT IT IS MALFUNCTIONING. TURN IT OFF, MONITOR IT AND CALL YOUR DEALER IF NECESSARY.
- HOPPER SHOULD ONLY CONTAIN PELLETS. HOPPER SHOULD BE KEPT FREE OF ANY FOREIGN OBJECTS AT ALL TIME TO PREVENT ANY DAMAGE TO THE STOVE.
- THE STOVE WILL NOT OPERATE DURING A POWER OUTAGE. IF AN OUTAGE DOES OCCUR, CHECK THE STOVE FOR SMOKE SPILLAGE. OPENING A WINDOW WILL PREVENT NEGATIVE PRESSURE AND SMOKE SPILLAGE IN THE ROOM.
- MAINTAIN PROPER VENTILATION. IT IS IMPORTANT THAT ADEQUATE OXYGEN IS BEING SUPPLIED TO THE FIRE FOR PROPER COMBUSTION. DURING THE WINTER SEASON, MAKE SURE THAT THE FRESH AIR INTAKE IS FREE OF ANY ICE, SNOW, ETC., AS THIS WILL STARVE THE FIRE OF AIR AND PREVENT THE PROPER OPERATION OF THE STOVE. MAKE SURE THE FRESH AIR INTAKE BACKDRAFT SHUTTER WORKS FREELY.
- DURING THE FIRST FEW FIRES, YOUR STOVE WILL EMIT AN ODOR AND A SMALL AMOUNT OF FUMES AS THE HIGH TEMPERATURE PAINT CURES OR BECOMES SEASONED TO THE METAL. MAINTAINING SMALLER FIRES WILL MINIMIZE THIS. AVOID PLACING ITEMS ON STOVETOP DURING THIS PERIOD TO AVOID DAMAGING THE PAINT SURFACE. MAKE SURE THE ROOM IS WELL-VENTILATED. OPEN WINDOWS. ODORS AND FUMES RELEASED DURING THIS PROCESS ARE UNPLEASANT BUT THEY ARE NOT TOXIC. ONCE YOU HAVE BURNED THE FIRST 40LBS OF PELLETS, IT IS RECOMMENDED TO INSPECT THE STOVE AND THE VENTING SYSTEM TO MAKE SURE THAT THERE IS NO LEAKS.
- NEVER USE GASOLINE, GASOLINE-TYPE LANTERN FUEL (NAPHTHA), FUEL OIL, MOTOR OIL, KEROSENE, CHARCOAL LIGHTER FLUID, OR SIMILAR LIQUIDS OR AEROSOLS. KEEP ALL SUCH LIQUIDS OR AEROSOLS WELL AWAY FROM THE STOVE WHILE IT IS IN USE.

## WARNING – APPLIANCE MAINTENANCE

- THIS STOVE SHOULD BE MAINTAINED AND OPERATED AT ALL TIMES IN ACCORDANCE WITH THESE INSTRUCTIONS. NOT FOLLOWING THE INSTRUCTIONS OF THIS MANUAL MAY CAUSE SMOKE SPILLAGE AND OTHER POTENTIAL HAZARDS. IT IS ALWAYS RECOMMENDED TO INSTALL SMOKE DETECTORS AND FIRE EXTINGUISHER IN A CONVENIENT LOCATION.
- NEVER TRY TO REPAIR OR REPLACE ANY PART OF THE STOVE UNLESS INSTRUCTIONS ARE GIVEN BY THE MANUFACTURER. ALL OTHER WORK SHOULD BE DONE BY A TRAINED TECHNICIAN.
- TURNING THE STOVE OFF DOES NOT DISCONNECT ALL POWER FROM THE STOVE. DISCONNECT THE POWER CORD BEFORE PERFORMING ANY MAINTENANCE OR REPAIRS ON THE STOVE.
- ALLOW THE STOVE TO COOL BEFORE CARRYING OUT ANY MAINTENANCE OR CLEANING. ASHES SHOULD BE PLACED IN A METAL CONTAINER WITH A TIGHT FITTING LID. THE CLOSED METAL CONTAINER SHOULD BE PLACED ON A NONCOMBUSTIBLE FLOOR OR ON THE GROUND, WELL AWAY FROM ALL COMBUSTIBLE MATERIALS, PENDING FINAL DISPOSAL. IF THE ASHES ARE DISPOSED OF BY BURIAL IN SOIL OR OTHERWISE LOCALLY DISPERSED, THEY SHOULD BE RETAINED IN THE CLOSED CONTAINER UNTIL ALL ASHES HAVE BEEN THOROUGHLY COOLED.
- THIS STOVE REQUIRES REGULAR MAINTENANCE AND CLEANING. FAILURE TO FOLLOW THE MAINTENANCE SCHEDULE (SEE SECTION 8.1.1 RECOMMENDED MAINTENANCE SCHEDULE) WILL REDUCE THE STOVE PERFORMANCE AND COULD EVENTUALLY DAMAGE IT. IT ALSO MAY LEAD TO SMOKE SPILLAGE IN YOUR HOME.



**WARNING:** This product can expose you to chemicals including carbon monoxide, which is known to the State of California to cause cancer, birth defects or other reproductive harm. For more information go to [www.P65warnings.ca.gov/](http://www.P65warnings.ca.gov/)

### 5.1.1 Zone Heating and How to Make It Work for You

Your new pellet stove is a space heater, which means it is intended to heat the area it is installed in, as well as spaces that connect to that area, although to a lower temperature. This is called zone heating and it is an increasingly popular way to heat homes or spaces within homes.

Zone heating can be used to supplement another heating system by heating a particular space within a home, such as a basement family room or an addition that lacks another heat source.

Although the stove may be able to heat the main living areas of your house to an adequate temperature, this stove must serve as a supplementary heat source. You should have a conventional oil, gas or electric additional heating system to provide heating in the home. The manufacturer cannot be responsible for additional heating costs associated with the use of an alternative heat source in case of stove failure or power outage.

Your success with zone heating will depend on several factors: Proper stove size, stove location, heating area, house layout, insulation and your climate zone.

## 5.2 Combustible

### 5.2.1 Proper Fuel

Each type of pellet has its properties and will burn differently. The amount of ashes produced can also vary greatly. Conventional pellets are those  $\frac{1}{4}$ " or  $\frac{5}{16}$ " in diameter and not over 1" long. Longer or thicker pellets will prevent proper pellet feed.

For example, if the pellets are very short, they will have more ease to accumulate and pile into the feed screws. Thus, the volume of pellets will be denser, which will lead to an increase in BTU. By contrast, longer pellets will pile less so the BTU will be reduced.

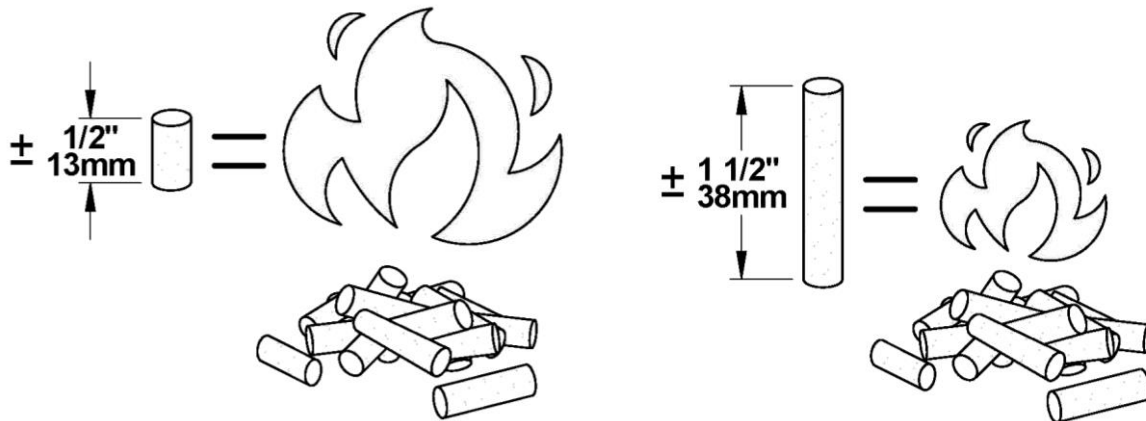

The bottom-feed system of this stove is designed and tested specifically for use with **premium** grade wood pellets **PFI certified** (Pellet Fuel Institute).

### WARNING

**BURNING OTHER TYPES OF PELLETS IS PROHIBITED. IT VIOLATES THE BUILDING CODES FOR WHICH THE STOVE HAS BEEN APPROVED AND WILL VOID THE WARRANTY.**

### 5.2.2 Where to Store Bags of Pellets

We recommend that you store your bags of pellets in a dry and well ventilated area if possible. Using dry pellets will increase the performance of your stove. You may want to have a bag or two in the same room as your stove for refueling but make sure to respect the minimum clearances to combustible materials and the space required for refilling and ash removal.

## 6 STOVE CONTROLS

### 6.1 General Information

The stove uses a touch screen, the latest technology in control devices. The blowers and feed system are controlled from this screen.

The touch screen can be found in the stove hopper. To install it, see **Appendix B**.

### 6.1.1 Touch Screen Controls, Operation and Configuration

The LCD control is an electronic visual display as well as a touch screen that will light-up as you touch any location on the display area. The main status page will then display different icons layout depending if the stove is on or not.

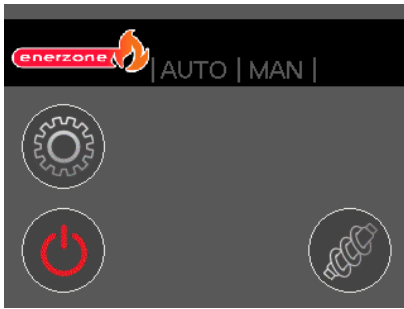

Main status page when the stove is OFF

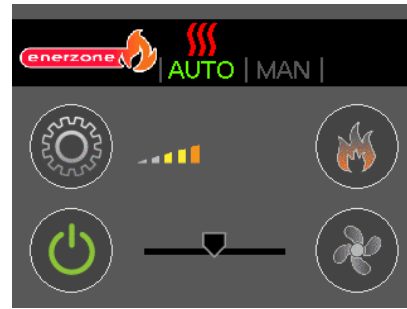

Main status page when the stove is running in thermostatic mode

#### Description of each main status page icon:

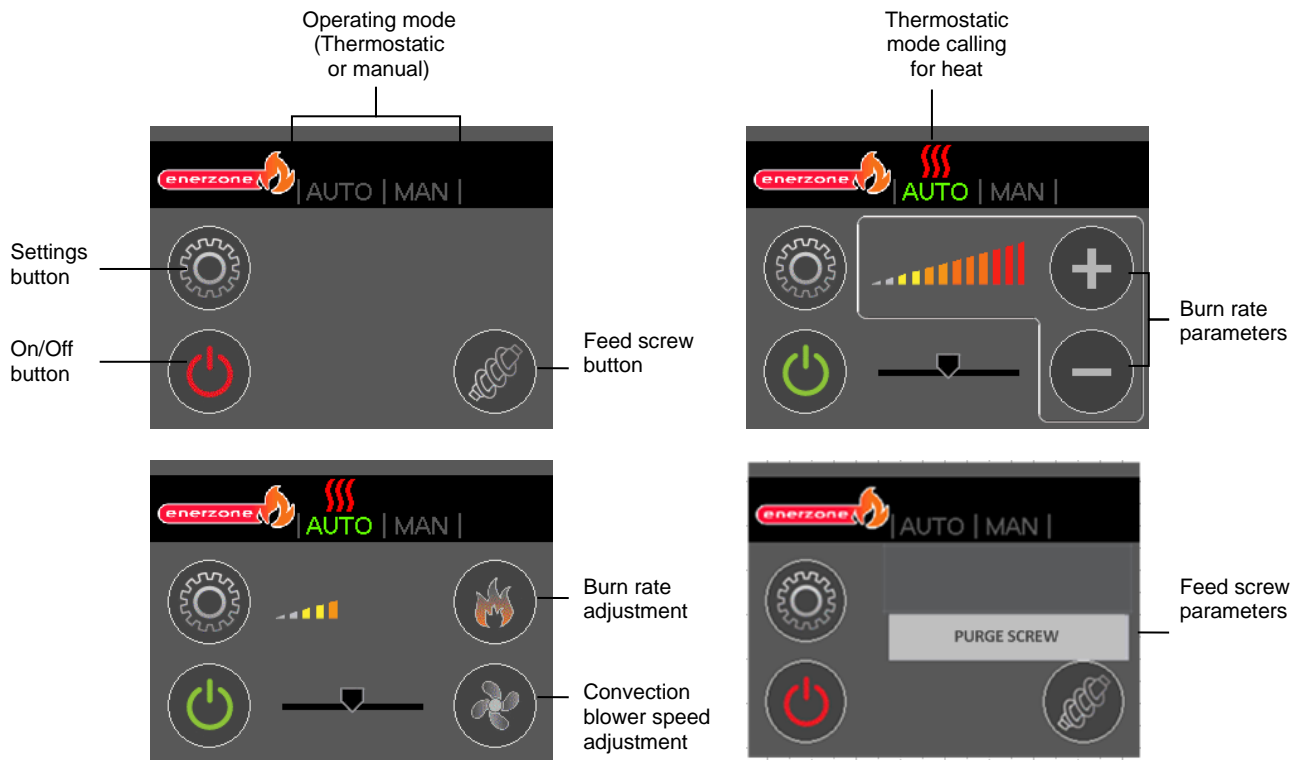

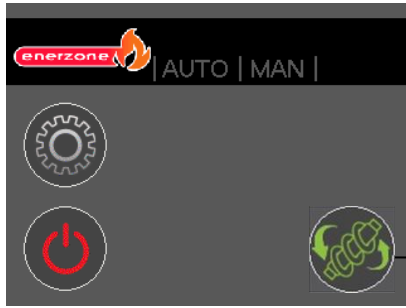

Feed screw button when on



Button to stop the feed screw

## 6.1.2 Configuration and Operation Diagram

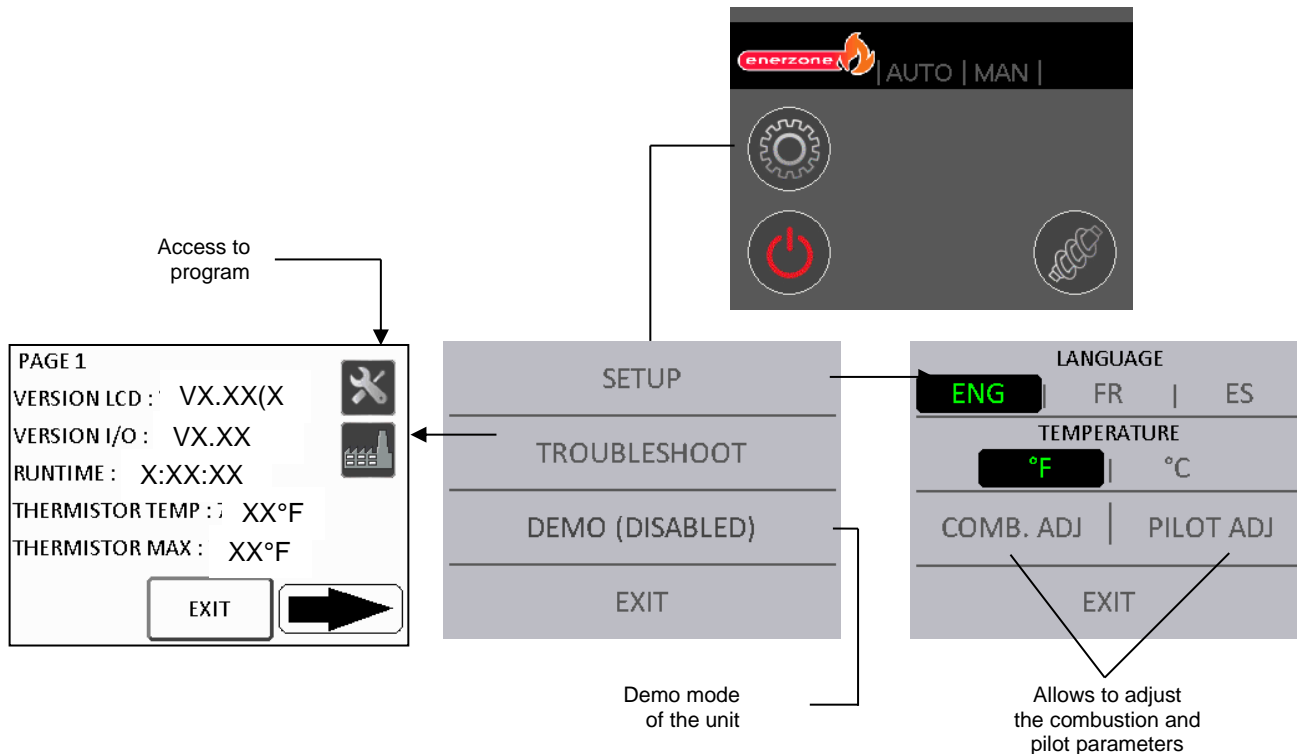

### 6.1.3 Selecting the Language and Temperature Unit (°F or °C)

From the main status page, choose the settings icon . Select "SETUP". You can choose between three languages, English, French or Spanish and between "°F or °C". Select "°F or °C" icon to display temperatures in the desired unit.

### 6.1.4 Viewing Statistics

From the main status page, choose the settings icon . Select "TROUBLESHOOT" and then using the arrows, go to page 2. Statistics will be available between page 1 to 3. These statistics can be very useful to a service technician or SBI technical support.

### 6.1.5 Adjusting the Combustion Level (Heat Output)



The stove's input range goes from 10,500 BTU to 45,000 BTU. To change combustion level, select the flame icon  on the main status page to display the "+" and "-" combustion level settings.

#### NOTE

**INPUT RANGE MAY VARY ACCORDING TO THE TYPE OF PELLETS BEING USED.**

Even though your stove can burn a large variety of wood pellets, we strongly recommend the use of high quality pellets to obtain maximum performance out of your stove (see **Section 5.2.1 Proper Fuel**). When using lower quality combustible, a restrictive venting system or using the stove in high altitude, you may need to adjust the "PILOT SETTING ADJUSTMENT" and the "FUEL QUALITY ADJUSTMENT". These two (2) settings are available from the "SETUP" page. See the following section for more details.

#### NOTE

**TO OBTAIN OPTIMAL RESULTS MAKE SURE THE VENTING SYSTEM, HEAT EXCHANGER AND EXHAUST CHANNELS ARE CLEANED BEFORE PERFORMING ANY SETTING CHANGES.**

## 6.1.6 Combustion Settings and Pilot Settings depending on Fuel Quality

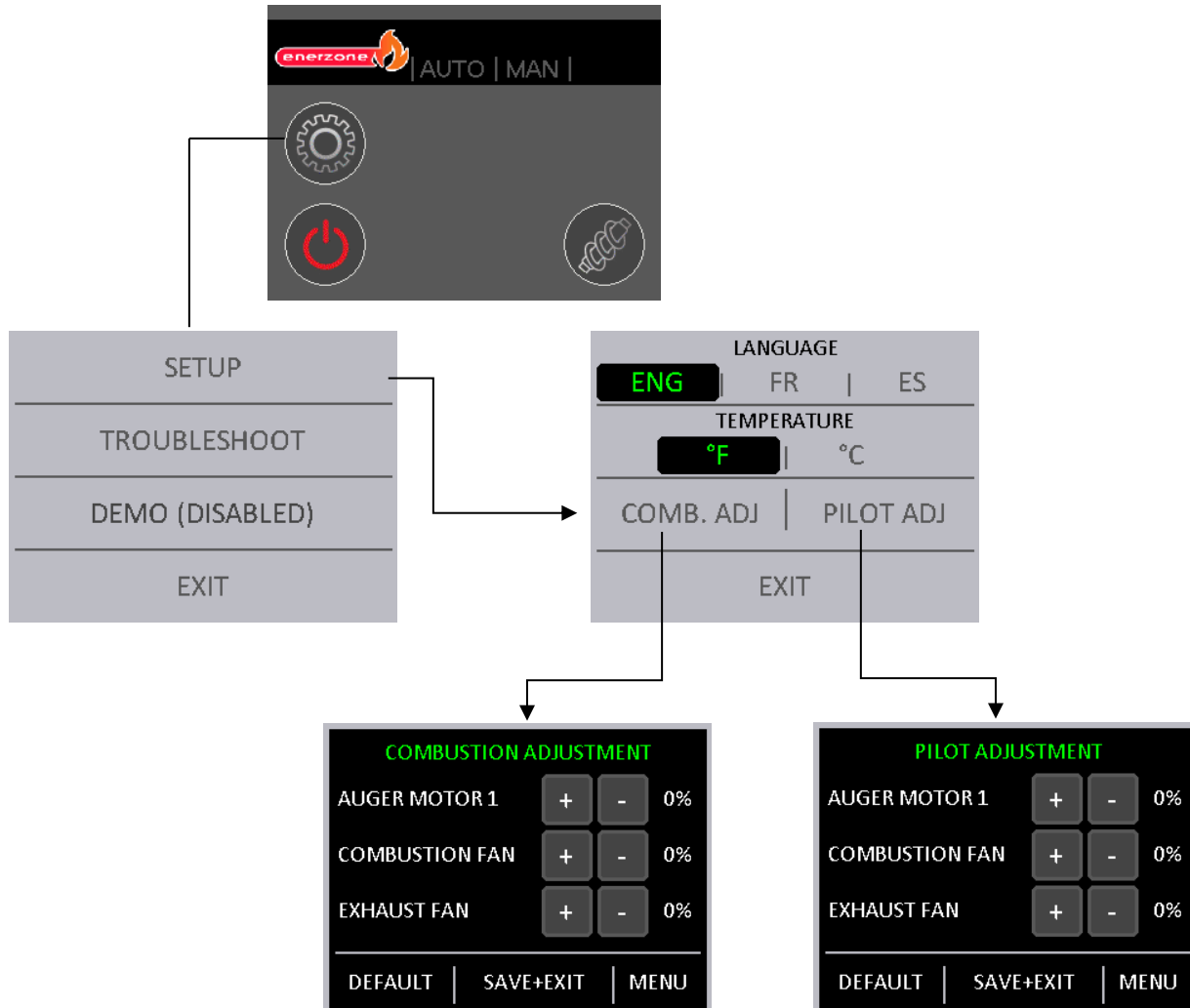

### 6.1.6.1 Pilot adjustment (pilot settings adjustment)

The “PILOT ADJUSTEMENT” will allow you to modify default settings by  $\pm 5\%$  for auger motor 1 and  $\pm 10\%$  for combustion and exhaust fan, but will only apply during pilot cycle. To restore default setting, select “DEFAULT”.

### 6.1.6.2 Combustion adjustment (fuel quality adjustment)

The “COMBUSTION ADJUSTMENT” will allow you to modify default settings by  $\pm 5\%$  for auger motor 1 and  $\pm 10\%$  for combustion and exhaust fan. To restore default setting, select “DEFAULT”.

Here are some situations where you may want to adjust these components:

#### Average speed of auger motor #1:

You may want to increase the auger motor #1 speed if fire goes out when combustion level is at its minimum setting. When burning poor quality pellets you may also need to reduce the auger motor speed to avoid unburned pellets to fall into the ash drawer at any combustion level.

### Speed of combustion fan:

You may want to reduce combustion fan speed if fire goes out when combustion level is at minimum setting. You may also want to increase combustion fan speed to avoid unburned pellets to fall into the ash drawer at any combustion level.

### Speed of exhaust fan:

You may want to reduce exhaust fan speed if natural draft is excessive and/or if the flame is low and almost at the same height at any combustion level. You may also want to increase the exhaust fan speed if vent configuration is too restrictive or flame height tends to be high at any combustion level.

## 6.1.7 Convection Fan Speed Adjustment

You can adjust the stove's convection fan speed for each combustion level selected. Thus, an adjustment range is offered to reduce or increase air distribution in the room. Take note that not all fan ranges are available, but the speed of the convection blower is consistent with the requested burn rate.

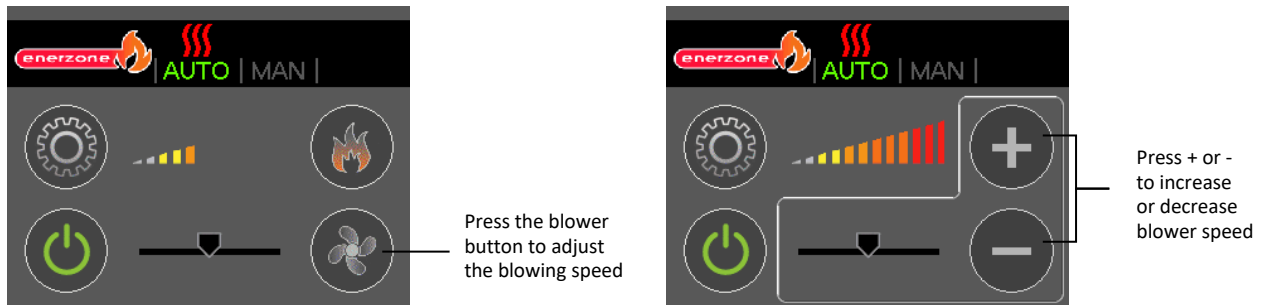

If overheating is detected, the convection fan speed will automatically go to the maximum setting and an envelope icon will appear on the Main Status Page. Press on the envelope icon to view the warning message. Meanwhile, the convection fan will operate at its highest setting until the stove reaches a safe temperature. Once the stove reaches that temperature, it will return to the previously selected convection fan selection.

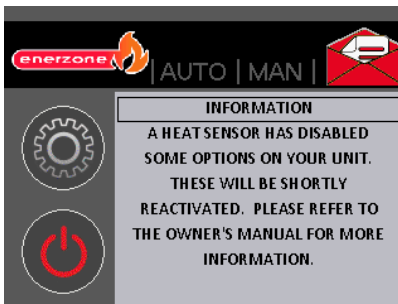

### 6.1.8 Selecting Manual or Thermostatic Mode

To change operating mode, press the desired mode from the Main Status Page.

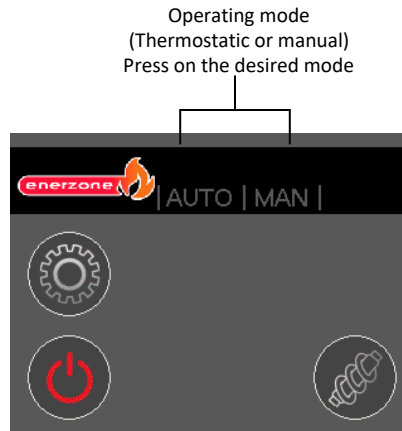

Indicates that the stove is in manual mode. It will therefore run continuously on the selected setting until it is manually modified, turned OFF or if the stove runs out of pellets.



Indicates that the stove is in thermostatic mode. The red waves indicate that the thermostat is calling for heat. It will heat at the selected combustion level until the thermostat has reached room temperature setting.

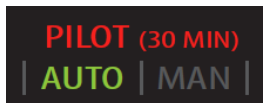

The waves will disappear once the thermostat has reached room temperature setting. At this time the combustion level will switch into the selected pilot mode until its cycle is completed. When thermostat calls for heat, the icon will change for the one with waves and combustion level will use the last setting.

### 6.1.9 Selecting the Pilot Cycle

To change the pilot cycle press the word "AUTO" from the Main Status Page. You can choose from one of the four different pilot cycles: "ALWAYS ON", "30 MINUTES", "60 MINUTES", or "ALWAYS OFF". The selected cycle will be displayed under the word "AUTO" on the main status page. Default setting is "ALWAYS OFF" since this is the most fuel efficient configuration.

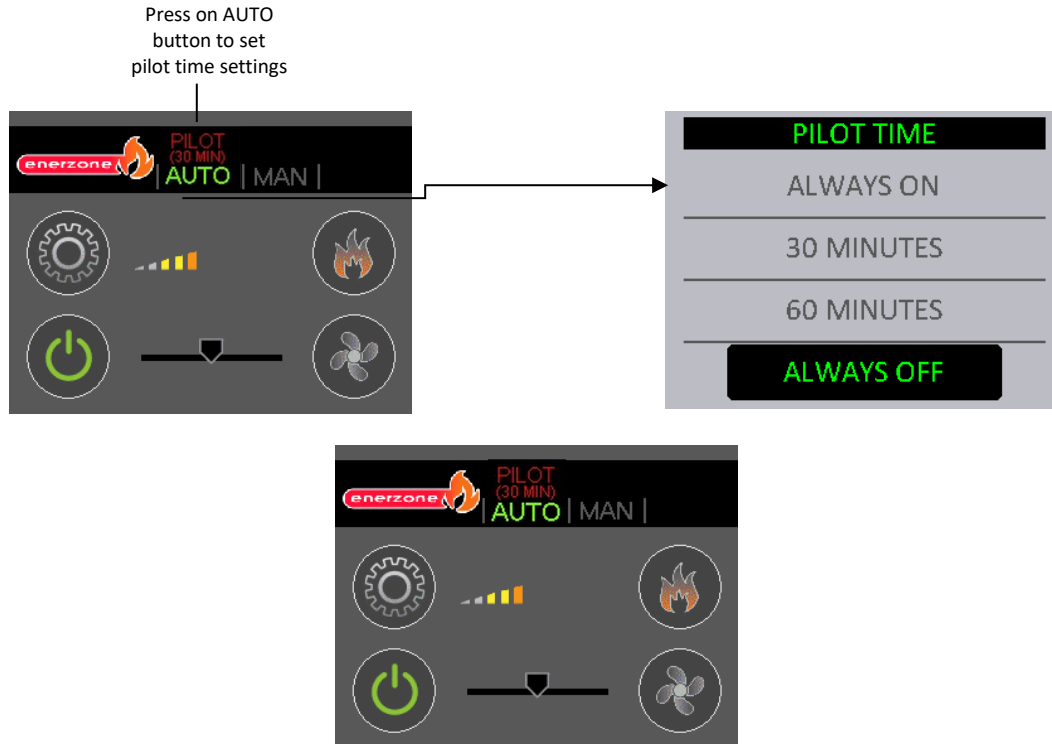

**Note:** Pilot feed rate is lower than the minimum combustion level feed rate.

#### 6.1.9.1 Always OFF

When the "ALWAYS OFF" pilot cycle is selected, the stove will shut down when the temperature set on the thermostat is reached. Every time the thermostat will call for heat, the stove will go through the complete ignition cycle.

#### 6.1.9.2 30 Minutes or 60 Minutes

The pilot cycle begins when temperature set on the thermostat is reached. It will last 30 or 60 minutes depending of the selected pilot cycle. If the thermostat does not call for heat before the end of the selected pilot cycle delay, the stove will shut down and will need to go through the complete ignition cycle when the thermostat calls for heat again.

#### 6.1.9.3 Always ON

The pilot cycle begins when temperature set on the thermostat is reached. When the "ALWAYS ON" pilot cycle is selected, the stove will remain on pilot mode until the thermostat calls for heat.

## 6.1.10 Purging the pellet feeding systems

**Note:** This function is disabled when the stove is running.

To purge the pellet feeding systems press the auger icon  and select “PURGE SCREW” in the displayed page.

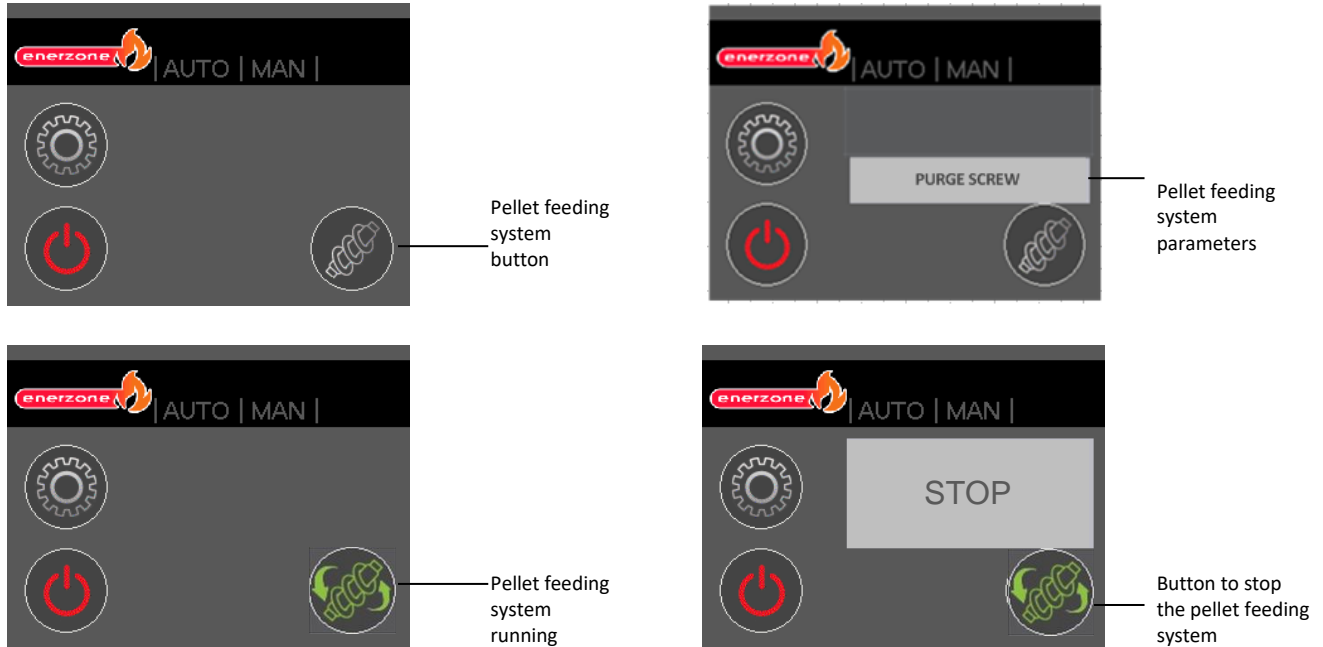

### 6.1.10.1 Purge Screw

Use this option to empty the feeding system at the end of the season. When selected, the system will turn for two minutes.

### 6.1.11 Demo Mode

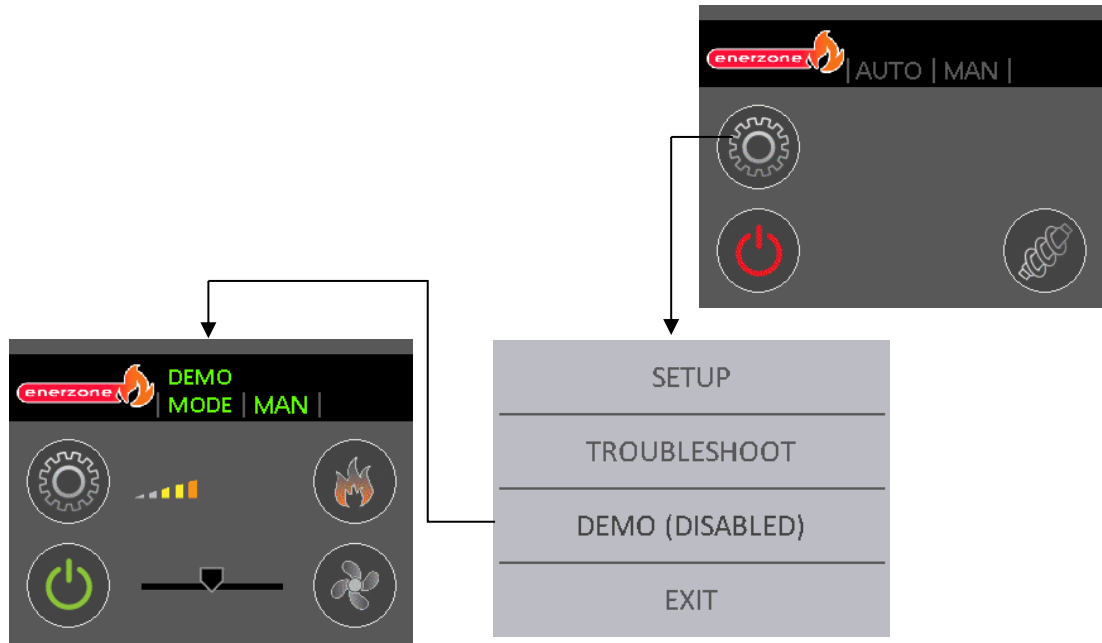

#### 6.1.11.1 Demo Mode Operation

The demo mode has been developed primarily to enable sales people to show the stove's functionalities in showrooms without starting it. Thus, when the "DEMO" mode is activated, the stove will not turn on but all the components will operate as if the stove was on. To disable the "DEMO" mode, you must press the word "DEMO MODE" followed by "OFF".



## 7 STOVE OPERATION

### 7.1 First Startup

Before starting your stove, make sure that the burn pot, the baffles and the maintenance access panels are properly installed. Make sure that the stove and the hopper have been emptied of all tools and accessories (see **Section 2.3: Before Operating Your Stove**). Also make sure that the venting system is properly sealed, that all doors and hopper lid are closed. Make sure that the hopper is full of pellets.

Press the “ON/OFF”  icon on the main status page. Note that the button will flash from green to yellow during the igniting mode.

If fire doesn't start within 20 minutes, a warning code **FAILED IGNITION** will appear. Refer to troubleshooting section for more details.

**WARNING: NEVER USE A GRATE OR OTHER MEANS OF SUPPORTING THE FUEL. ONLY USE THE APPROVED STOVE BURN POT.**

### 7.2 Everyday Startup

Before starting the stove, make sure there is enough pellets in the hopper and that the recommended maintenance schedule has been followed (see **Section 8.1.1 Recommended maintenance schedule**)

then press the “ON/OFF”  icon on the main status page. Note that the button will flash from green to yellow during the igniting mode.

### 7.3 Running Out of Pellets

If your stove runs out of pellets, the fire will slowly go out; the convection fan will run until the heat sensor on the exhaust fan reads 115°F. The cooling cycle will take a few minutes before all other motors stops. When this temperature is reached, a warning message “NO FUEL” will be displayed on the LCD screen.

To restart the stove, wait until all components stop running (usually 10 minutes after the warning message has been displayed). Press the “RESET” button, refill the hopper, and press the “ON/OFF”  icon on the main status page.

## 7.4 Refueling

While the stove is running, you have up to 3 minutes to refill the hopper with pellets. Note that opening the hopper lid will stop the auger from feeding pellets to the stove. If the hopper lid is left open more than 3 minutes, the stove will stop and a warning code "HOPPER LID OPEN" will appear on the LCD screen. To restart the stove, close the lid, press the "RESET" button, and then press the "ON/OFF" icon



on the Main Status Page.

**NOTE: Keep hopper lid closed at all times except when refueling. Do not overfill the hopper.**

## 7.5 Shutting Down Procedure

To turn your stove off, press the "ON/OFF" icon  on the Main Status Page. The cooling cycle will take a few minutes and the blowers will continue to function while the stove is cooling down.

**IMPORTANT: DO NOT DISCONNECT THE POWER CORD TO TURN OFF THE STOVE.**

## 7.6 Signs of an Overheating Stove

Under normal conditions, the flame should have a bright yellow color and be very active, but stable. If you see the flame getting lazy, very high and orange, it may be a sign that there is something wrong. Usually, overheating issues are caused by too much restriction in the venting system, a blocked heat exchanger, a lack of combustion air or a lack of maintenance.

If this happens, your stove will become very hot. If the stove becomes too hot, "UNIT OVERHEAT" code will appear on the LCD screen. Before starting the stove again make sure the recommended maintenance has been done properly. Press the "RESET" button and then press the "ON/OFF" icon



on the Main Status Page. If a "UNIT OVERHEAT" code occurs twice, call you dealer. He will be able to give you some recommendations so this code won't appear again.

**WARNING: IF YOU CHOOSE A STOVE THAT IS TOO SMALL FOR YOUR HOUSE AND YOU NEED TO OPERATE IT AT THE MAXIMUM SETTING FOR A LONG PERIOD OF TIME, YOU MAY END UP OVERHEATING THE STOVE. THE STOVE AND ITS COMPONENTS LIFE EXPECTANCY WILL BE REDUCED.**

**WARNING: IF ANY EXTERNAL PART OF THE STOVE BEGINS TO GLOW RED, THE STOVE IS OVERHEATING. IMMEDIATELY TURN THE STOVE OFF. DO NOT UNPLUG IT AND DO NOT OPEN THE DOOR. UNPLUGGING THE STOVE WILL DISABLE ALL THE SAFETY FEATURES OF THE STOVE.**

## 8 MAINTENANCE

### 8.1 Stove Maintenance

#### 8.1.1 Recommended Maintenance Schedule

Use this as a guide when used under average conditions.

Components	Weekly or after ± 250 pounds	Twice a year or after ± 1 tons	Annually or ± 2 tons
Baffle	Vacuum		
Bottom airwash inlet	Vacuum		
Burn Pot	Scrape / Vacuum		
Glass	Clean		
Ash Drawer	Empty / Vacuum		
Combustion Chamber	Vacuum	Vacuum / Brush*	
Heat Exchanger	Brush	Scrape and Vacuum*	
Exhaust Channels (through access traps)		Vacuum*	
Exhaust Blower		Vacuum*	
Combustion Blower		Inspect*	
Convection Blower		Vacuum*	
Venting System		Inspect / Sweep*	Sweep and Clean
Gaskets		Inspect	
Hopper			Empty / Vacuum

\*Cleaning frequency may vary depending on the type of fuel used. Fuel with higher ash content will increase cleaning frequency. See **Section 5.2.1 Proper Fuel** for recommended combustibles.

### WARNING

- FAILURE TO CLEAN AND MAINTAIN THIS STOVE AS INDICATED CAN RESULT IN POOR PERFORMANCE AND SAFETY HAZARDS.
- NEVER CLEAN WHEN HOT.
- THE USE OF A DOMESTIC, CENTRAL OR COMMERCIAL VACUUM CLEANER TO PERFORM THE MAINTENANCE OF YOUR PELLET STOVE IS NOT RECOMMENDED. ASH PARTICLES MAY DAMAGE THE MOTORS OF THESE APPLIANCES. FURTHERMORE, EMBERS THAT ARE STILL HOT MAY SET YOUR VACCUM CLEANER'S CONTENT ON FIRE. THE USE OF AN ASH VACCUM CLEANER IS HIGHLY RECOMMENDED.
- ASHES SHOULD BE PLACED IN A METAL CONTAINER WITH A TIGHT FITTING LID. THE CLOSED METAL CONTAINER SHOULD BE PLACED ON A NONCOMBUSTIBLE SURFACE, WELL AWAY FROM ALL COMBUSTIBLE MATERIALS, PENDING FINAL DISPOSAL. IF THE ASHES ARE DISPOSED OF BY BURIAL IN SOIL OR OTHERWISE LOCALLY DISPERSED, THEY SHOULD BE RETAINED IN THE CLOSED CONTAINER UNTIL ALL CINDERS HAVE BEEN THOROUGHLY COOLED.

### 8.1.2 Cleaning the Baffle and the Combustion Chamber

**Top baffle:** Pull the top baffle towards you. When release from the notches, lower it and pull it towards you to take it out of the combustion chamber.

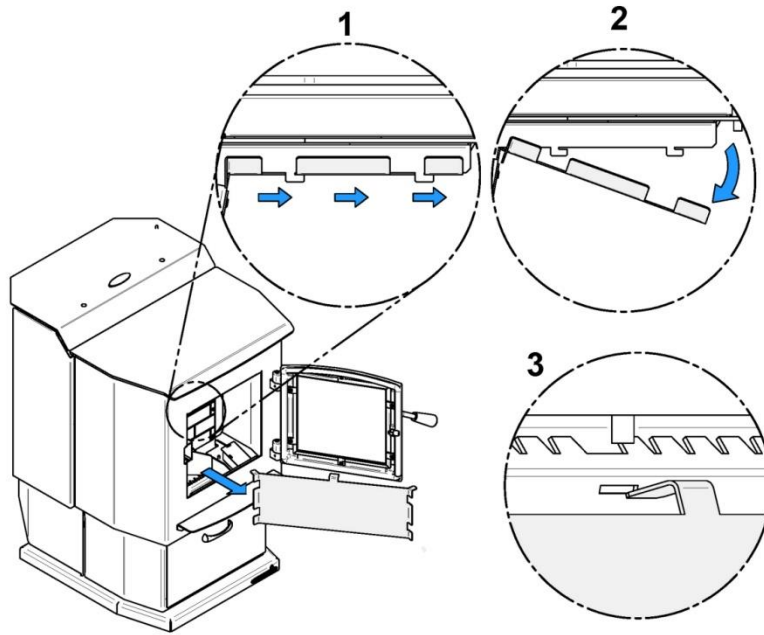

**Bottom baffle:** Lift the baffle, pull it towards you and take it out of the combustion chamber.

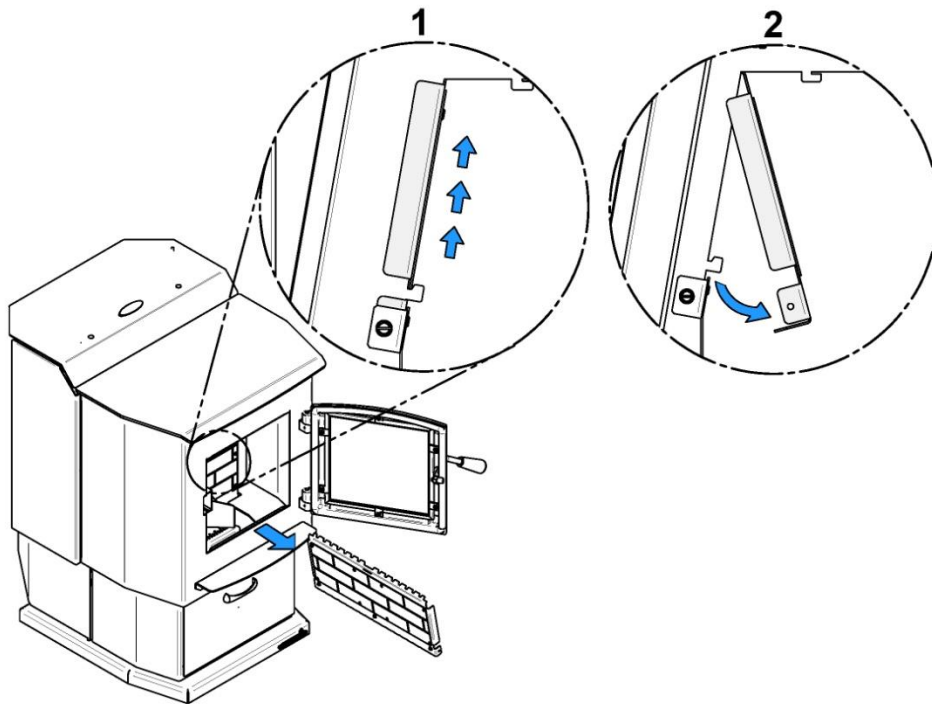

**Combustion chamber:** With a brush and a vacuum clean every fins of the cast iron heat exchanger (1) and (2). Also clean the lip over the door (3).

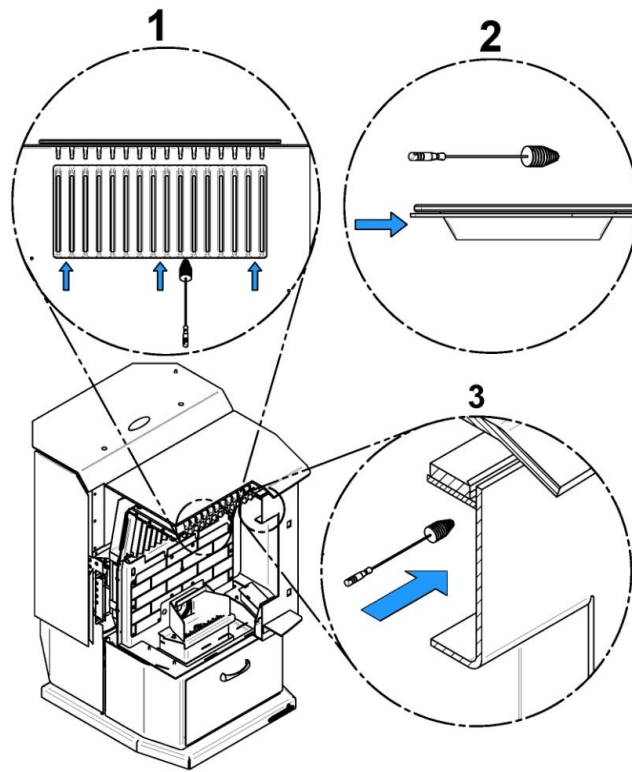

With a brush, also clean behind the plate.

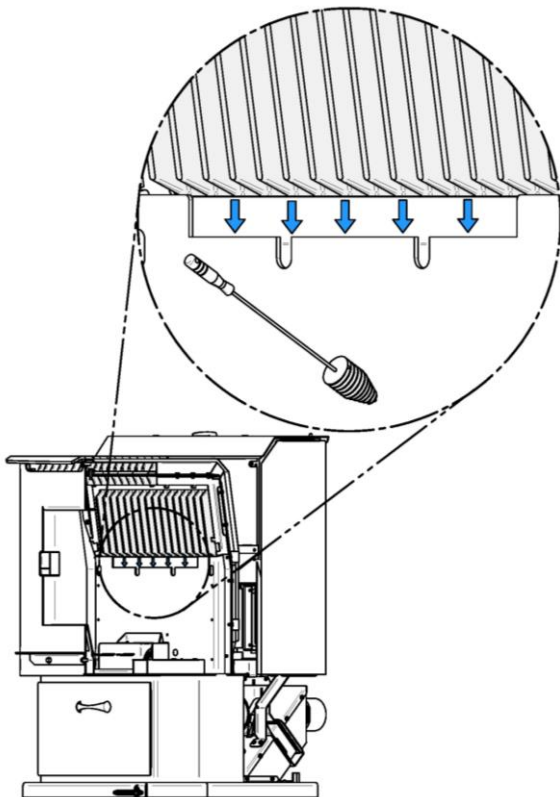

#### NOTE

IT IS HIGHLY RECOMMENDED TO CLEAN THE EXHAUST CHANNEL COMBUSTION CHAMBER (SEE SECTION 8.1.3: EXHAUST CHANNEL AND EXHAUST BLOWER MAINTENANCE) IMMEDIATELY AFTER CLEANING THE HEAT EXCHANGER.

### 8.1.3 Exhaust Channel and Exhaust Blower Maintenance

Exhaust channel is accessible from the front and the exhaust blower is located on left hand side of the stove. The following procedure demonstrates how to perform inspection and cleaning:

In order to access the exhaust channel removed the ash drawer access panel (A) and the ash drawer (B). Then remove the exhaust channel plug (C).

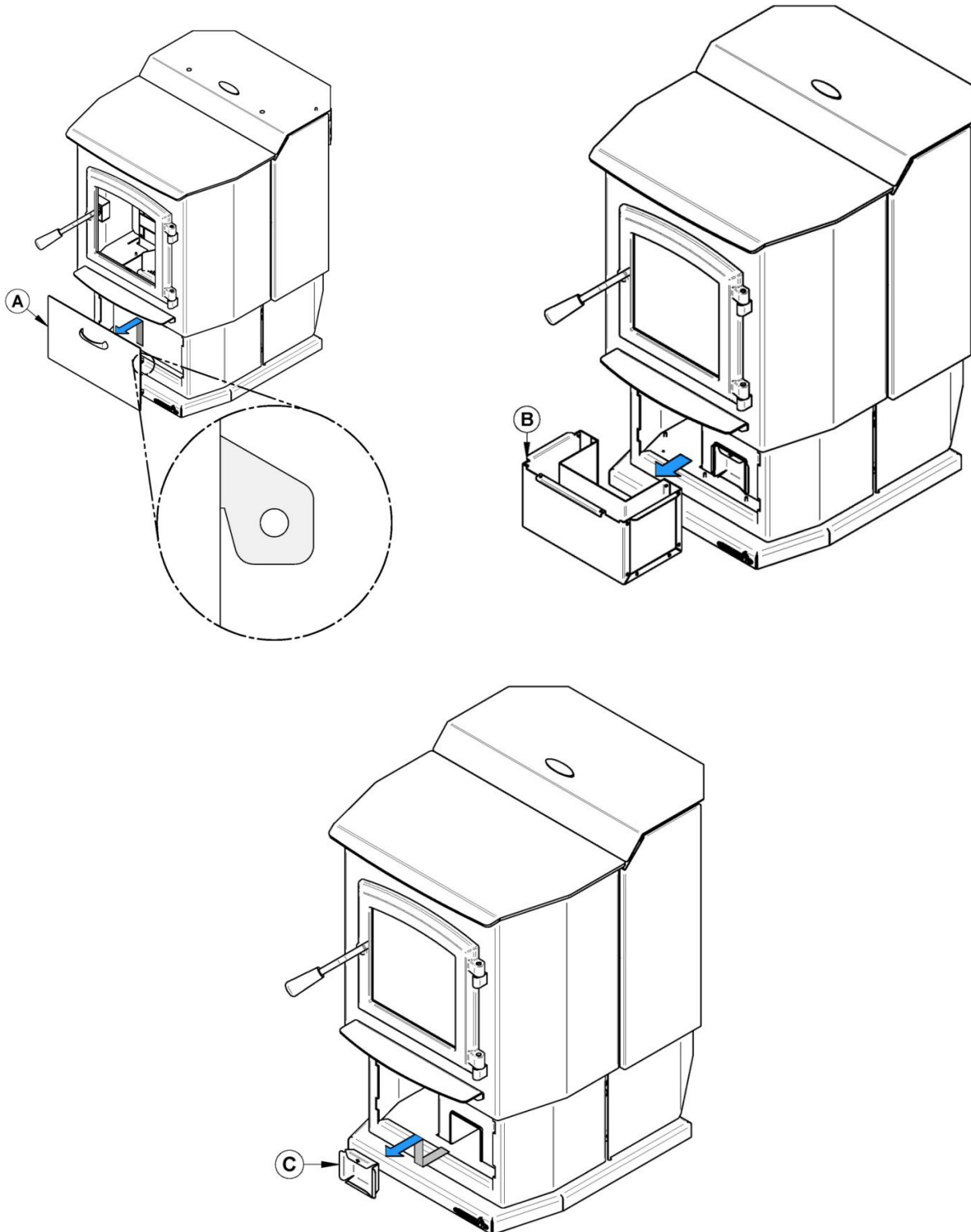

Using a brush and an ash vacuum brush and vacuum all the dirt and ashes from the exhaust channels.

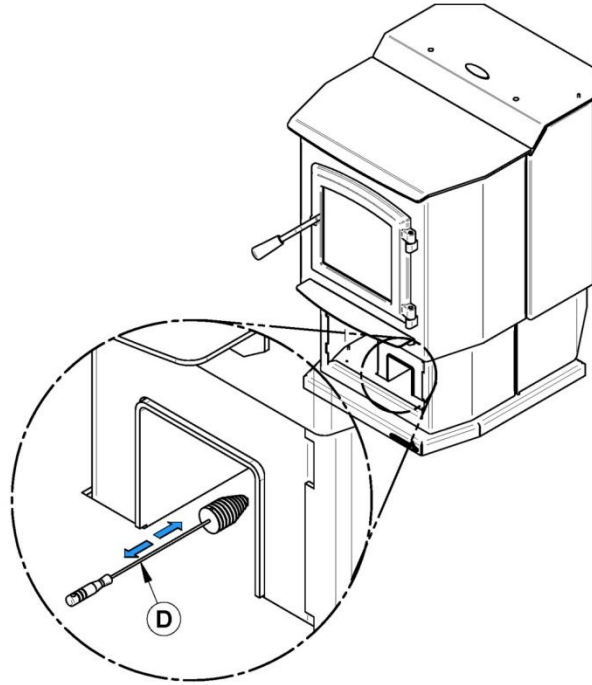

Open the hopper lid and remove the left side decorative panels (E). Unscrew the 2 screws (B).

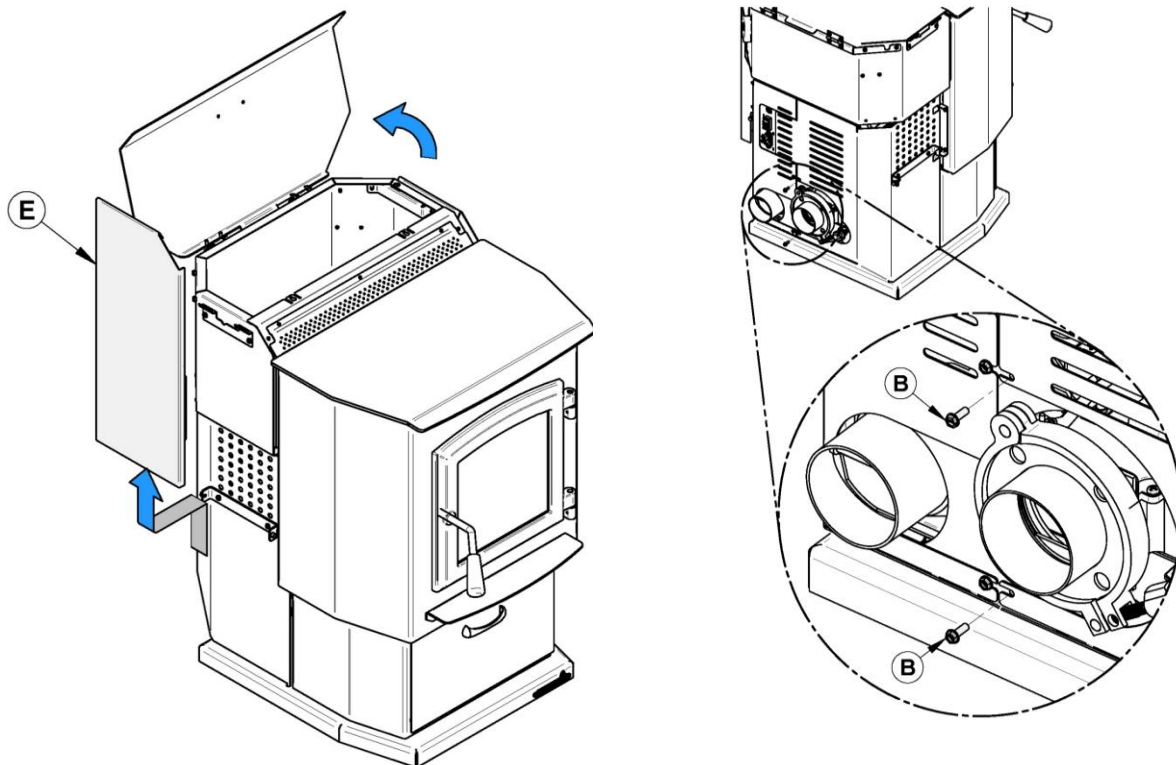

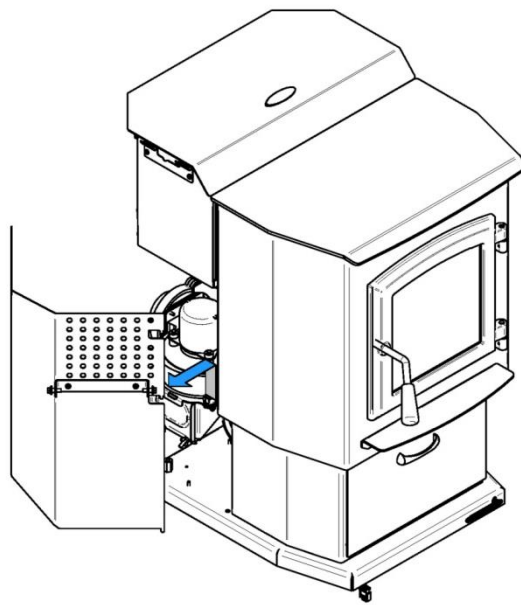
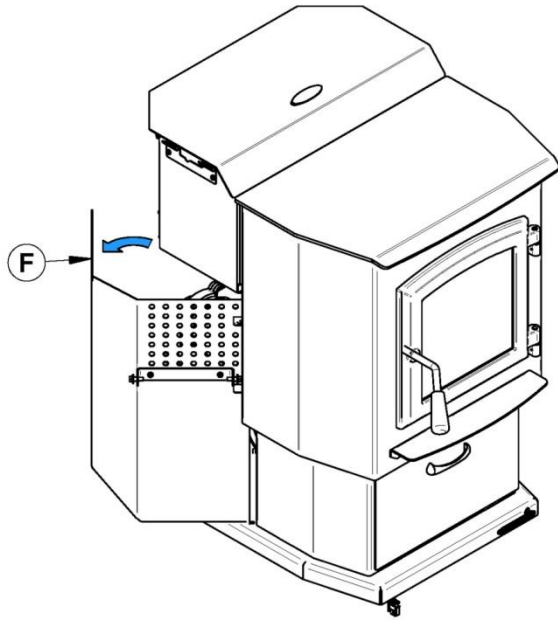

Turn the panel **(F)**. Slightly lift it in order to remove it.

Remove the clean out trap **(H)** by unscrewing both wing nuts **(G)**. Using a brush and an ash vacuum brush and vacuum all the dirt and ashes from the exhaust channel. Make sure that the gaskets are still in good condition, replace them if needed.

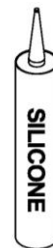
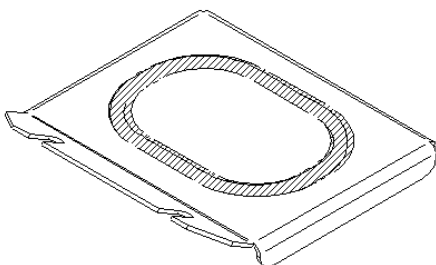
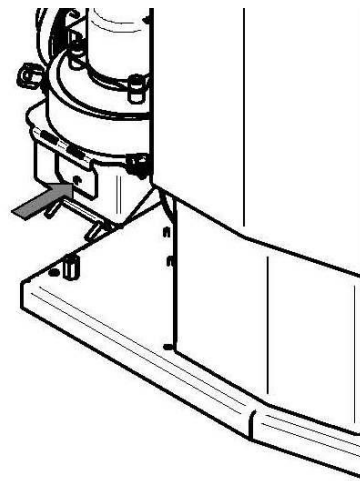
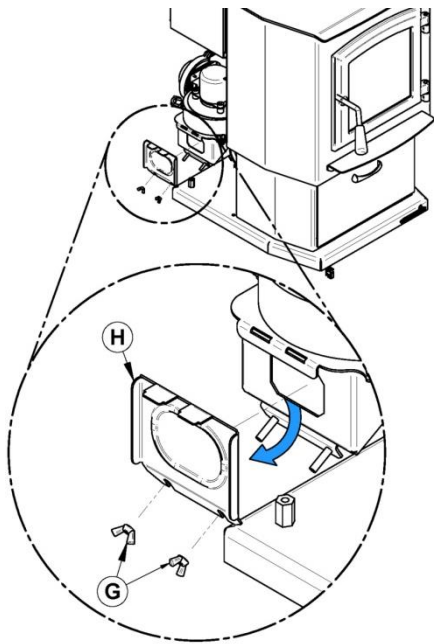

### 8.1.4 Cleaning the Burn Pot

The burn pot must remain clean and the holes should not be obstructed by combustion residues (ashes or clinkers).

1. Clean the burn pot using a scraper.

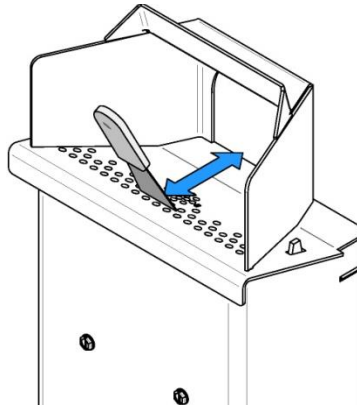

2. The burn pot simply sits onto the air intake channel. You must lift to remove it from the stove. Two small pins guide the burn pot in place. Make sure that the burn pot is well in place before turning on the stove (as shown in the diagram).

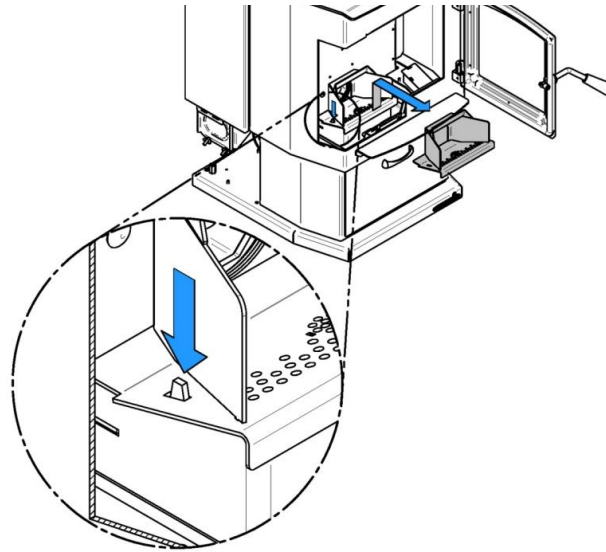

3. If necessary, clean the air intake channel. Vacuum the combustion residues located under the burn pot. On the following view this is the hatched area.

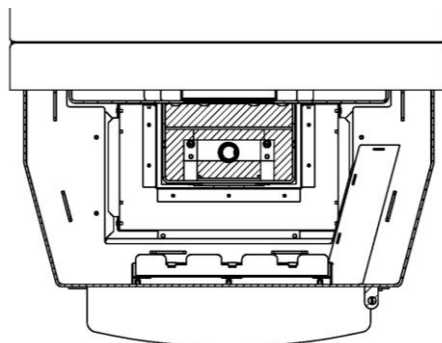

### 8.1.5 Ash Removal

1. To empty the ash drawer (A) of its contents, open the ash pan access door by lifting the panel.
2. Empty the ash drawer, vacuum around the ash drawer and the bottom of the combustion chamber.

**WARNING: ASH PAN MUST BE IN PLACE AND THE ASH PAN ACCESS DOOR MUST BE KEPT CLOSED AT ALL TIMES WHEN THE STOVE IS IN USE.**

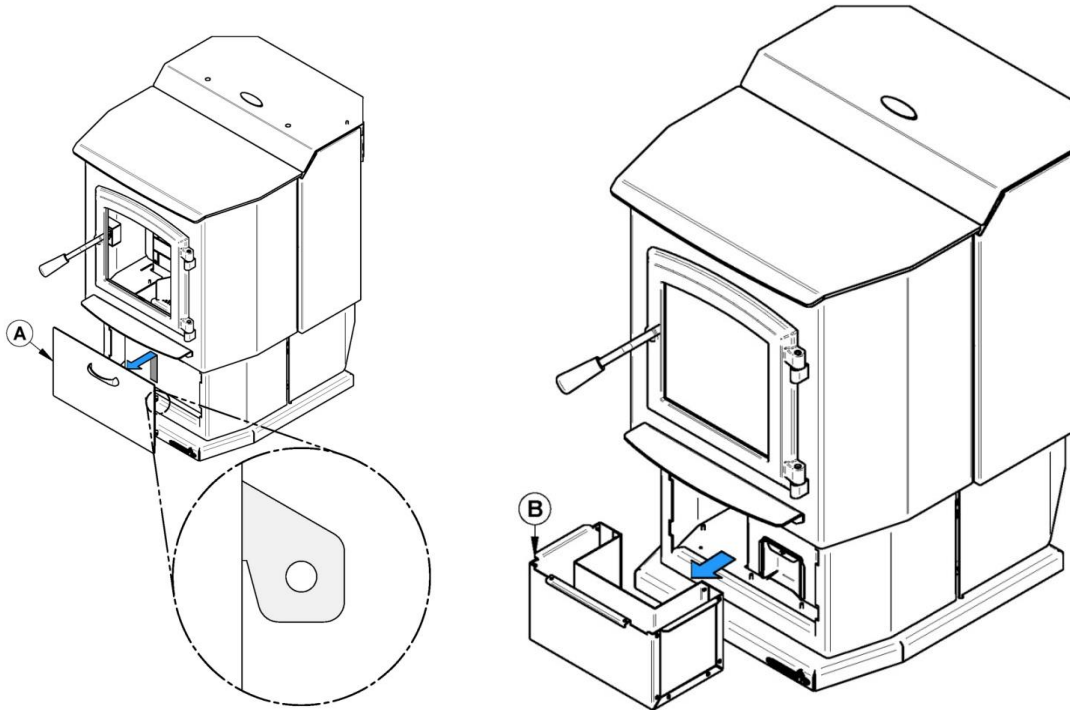

### 8.1.6 Cleaning the Air Wash System

Vacuum the ashes that may have accumulated into the airwash system. This will allow an optimum air flow along the inside portion of the glass and prevents the glass from sooting-up. Open the door and removed the cover of the airwash system (I).

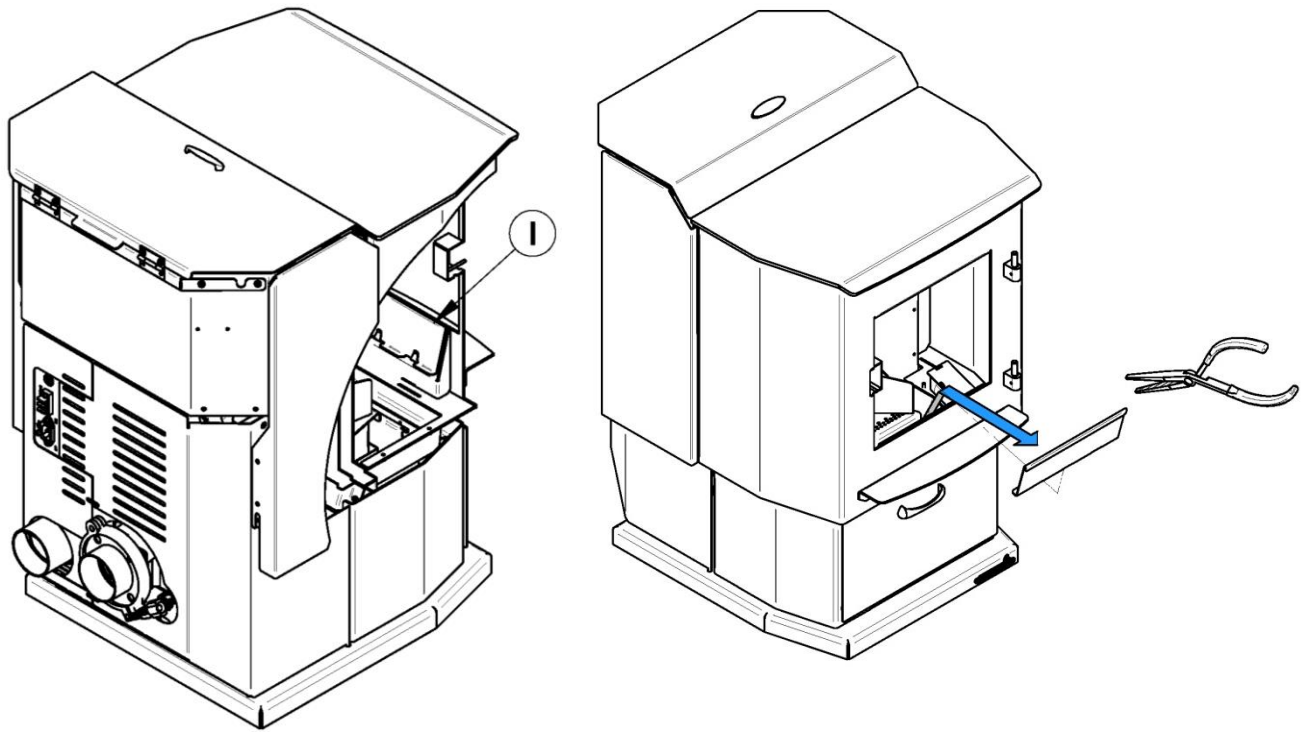

Vacuum the ashes accumulated in the gridded area (J).

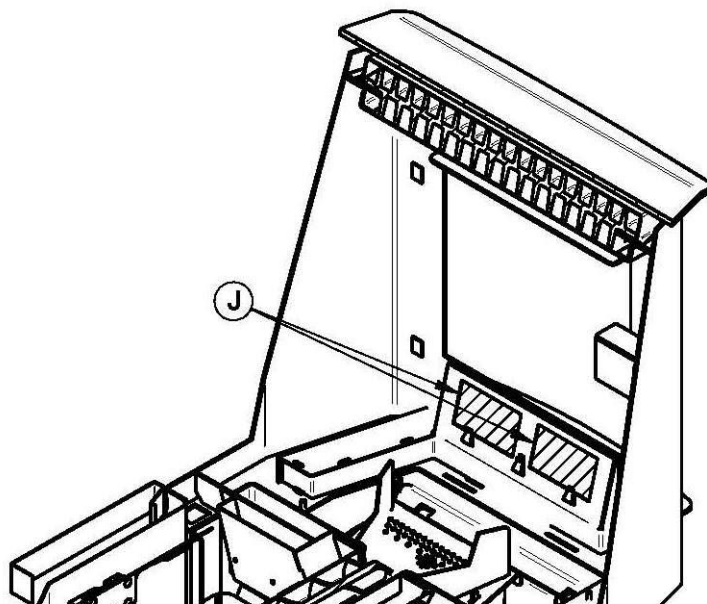

### 8.1.7 Glass Care

Clean door glass when necessary. The use of a stove glass cleaner is recommended. Regular household glass cleaners will not remove creosote properly.

#### WARNING

- NEVER USE ABRASIVE CLEANERS ON THE GLASS OR ON ANY PLATED PART.
- DO NOT CLEAN THE GLASS WHILE IT'S HOT.
- DO NOT FORCE, STRIKE OR ADOPT ANY BEHAVIOUR THAT COULD WEAKEN THE GLASS DOOR.
- DO NOT OPERATE THE STOVE WITH THE GLASS REMOVED, CRACKED OR BROKEN.

### 8.1.8 Replacement of Broken Door Glass

Carefully remove any loose pieces of glass from the doorframe. Dispose of all broken glass properly. A broken glass must be replaced with an identical ROBAX (ceramic glass) 5 mm thick with the dimensions 10 3/8" x 10 3/8". Refer to replacement parts section.

#### WARNING



ALWAYS WEAR SUITABLE GLOVES WHILE HANDLING BROKEN GLASS.

#### WARNING

- REPLACEMENT GLASS SHOULD ONLY BE PURCHASED FROM AN AUTHORIZED DEALER (SEE "REPLACEMENT PARTS" SECTION). TEMPERED GLASS OR ORDINARY GLASS WILL NOT WITHSTAND THE HIGH TEMPERATURES OF THE STOVE.
- IF YOU HAVE TO CHANGE THE DOOR GLASS, MAKE SURE YOU INSTALL THE NEW GASKETS AT THE SAME PLACE AS THE ORIGINAL IN ORDER TO KEEP THE AIRWASH WORKING PROPERLY.

### 8.1.9 Door Gasket Maintenance

It is important to maintain the door gasket in good condition. After a while, the gasket will wear and compress; adjusting the door may then be required. If the door adjustment is not sufficient, replace the door gasket with a genuine part. If the stove door is not properly sealed, it will be difficult to keep the door glass clean and combustion gases may leak into the room.

### 8.1.10 Door Adjustment

In order for your stove to burn at its best efficiency, the door must provide a perfect seal with the firebox. Therefore, the gasket should be inspected periodically making sure to obtain an air tight fit. Air tightness can be improved with a simple latch mechanism adjustment. To adjust:

1. Remove the lock pin by pulling and turning with pliers. Turn the handle counter clock wise one turn to increase pressure.
2. Re-install the lock pin (spring pin) with a small hammer

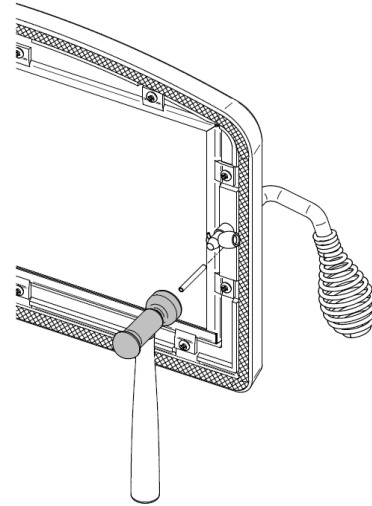
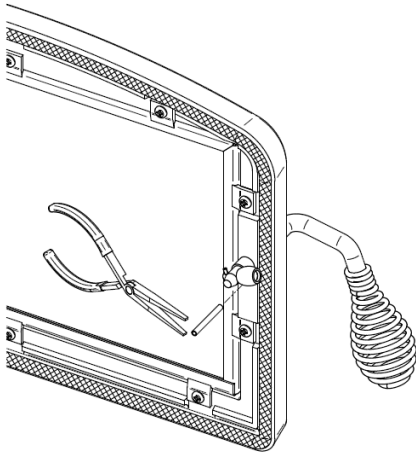

## 8.2 Venting System Maintenance

**CAUTION:** REGULARLY EXAMINE THE VENTING SYSTEM, THE JOINTS, AND THE SEALING TRIMS TO ENSURE THAT THE SMOKE AND THE COMBUSTION GASES ARE NOT DRAWN BY THE CONVECTION BLOWER.

The most efficient method to sweep the venting system is by using a 4" pellet brush depending on your installation. Brush downwards so ash, soot and creosote residues will come off the inner surface and fall at the bottom of the clean out tee where they can be easily removed. The venting system must be in good condition and kept clean.

**WARNING:** IF A SIGNIFICANT LAYER OF CREOSOTE HAS ACCUMULATED (3MM / 1/8" OR MORE), IT MUST BE REMOVED IMMEDIATELY TO ELIMINATE THE RISK OF A CHIMNEY FIRE.

### **8.2.1 Dealing With a Chimney Fire**

Regular chimney maintenance and inspection can prevent chimney fires. If you have a chimney fire, follow these steps:

1. Alert your family of a possible danger;
2. If you need assistance, call the fire department;
3. If possible, use a dry chemical fire extinguisher, baking soda or sand to control the fire. Do not use water, as it may cause dangerous vapor explosions;
4. Check outside to ensure that sparks and hot embers coming out of the chimney are not igniting any combustible material close by;
5. Do not use the stove again until your chimney and stove have been inspected by a qualified chimney sweep or a Fire Department Inspector.

**CAUTION: CLEANOUT OF THE STOVE AND THE VENTING SYSTEM IS ESPECIALLY IMPORTANT AT THE END OF THE HEATING SEASON TO MINIMIZE CORROSION DURING THE SUMMER MONTHS, CAUSED BY ACCUMULATED ASH.**

### **8.2.2 Soot and Fly Ash**

The combustion products contain small particles of fly ash. Fly ash can accumulate especially in horizontal sections of exhaust pipe and restrict the flow of combustion gases. Incomplete combustion, produced when igniting, shut down or misuse of the stove will cause some soot formation which can accumulate in venting system. The venting system must be inspected at least twice a year to determine if cleaning is necessary.

## 9 TROUBLESHOOTING

When you have issues with your stove, your first reaction may be to call technical support. This section will help you save time and money by enabling you to solve simple problems by yourself.

Most common problems are generally caused by the following five factors:

1. Wrong operation or lack of maintenance;
2. Bad installation;
3. Poor quality combustible;
4. Component failure;
5. Factory defect.

The stove is equipped with a pc board that allows the stove to diagnose itself. It is thus important not to unplug the stove if there is an issue with it. First, because unplugging the stove will disable all the security features of the stove, and second, because you will not be able to see the error code given by the stove to understand what is the problem. It is thus important to read carefully this section before calling technical support.

The following sections will help you test each component individually and will also give you many tips in how to solve any problems related to a specific error code.

**NOTE: IF YOU NEED TO CONTACT YOUR DEALER OR TECHNICAL SUPPORT, MAKE SURE TO HAVE THE MODEL OF YOUR STOVE AND THE SERIAL NUMBER ON HAND. (THEY CAN BE FOUND ON THE CERTIFICATION LABEL INSIDE THE HOPPER LID).**

### 9.1 Validating Status

When using your stove, you can validate at any time, the status of any of the following components:

- Electronic components (low power rated)
  - o F160 (security heat sensor)
  - o L-250A (security heat sensor)
  - o Pressure sensor (security sensor)
  - o Hopper switch (mechanical security sensor)
  - o RTD (temperature probe)
  - o Thermostat (temperature regulator device)
- Electrical components:
  - o Igniter (heater)
  - o Combustion blower (will feed fire with fresh air)
  - o Convection blower (will send hot air into the room)
  - o Exhaust blower (will extract combustion gas out of the stove)
  - o Auger motor 1 (located under the hopper)
  - o Auger motor 2 (will feed the fire with pellets)

**WARNING: RISK OF ELECTRICAL SHOCK. IF YOU NEED TO MANUALLY TEST, MANIPULATE OR REPLACE ANY COMPONENTS, THE STOVE NEEDS TO BE DISCONNECTED FROM THE WALL OUTLET.**



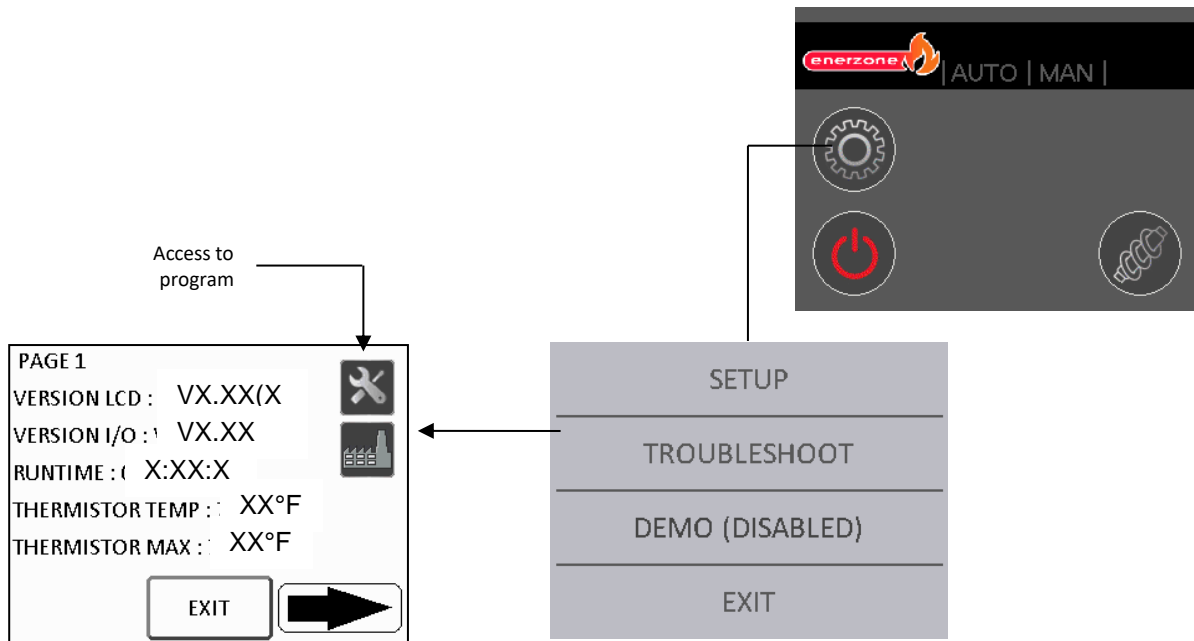





To validate the status of a component, you need to go to the “TROUBLESHOOT” page from the Main Status Page. Once there you will be able to navigate with the arrows through 7 different pages.



Page 1 provides information on the software version of the stove's two electronic cards. In addition, you have the total number of hours your stove has been in operation, the temperature of the exhaust gases and the maximum temperature that your stove has reached.

Pages 2 and 3 will give you statistics on the number of times a specific error code has occurred.

From page 4 is the list of operating states of the electronic components. If the square is green, it means that the operating state of the component is normal, no matter if it's on the left column or right. If the square is red, it means that the operating condition is abnormal. This screen will give you the operating status in real time, meaning that when the stove is running, if a state change occurs, you will see it immediately.

WITH GREEN ICONS			
PRESSURE			Pressure switch is closed. This condition is normal if the stove is in operation.
PRESSURE			Pressure switch is open. This condition is normal if the stove is OFF.
WITH RED ICONS			
PRESSURE			Pressure switch is closed. This condition is abnormal if the stove is OFF.
PRESSURE			Pressure switch is open. This condition is abnormal if the stove is in operation.

## 9.2 Testing Components

If you suspect an electrical component to be defective, you can test it from the “TROUBLESHOOT” page.

From the Main Status Page, press the Settings icon  and choose “TROUBLESHOOT” in the menu. Page 5 and 6 will allow you to test every electrical component. Note that you will be able to test only components when the stove is OFF and that all the components are no more in function.

For example, if you press on the white square next to “GEAR MOTOR 1”, the auger 1 will turn for 30 seconds. This will give you the possibility to see the auger running and hear the motor running as well.

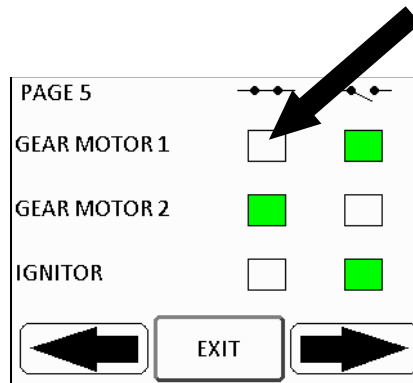



## 9.3 Main Error Codes, Possible Causes and Solutions

### WARNING



**RISK OF ELECTRICAL SHOCK. IF YOU NEED TO MANUALLY TEST, MANIPULATE OR REPLACE ANY COMPONENTS, THE STOVE NEEDS TO BE DISCONNECTED FROM THE WALL OUTLET.**

This section contains main error codes, possible causes and many suggestions to guide you in resolving them. After giving an error code, your stove will shut down by itself and start a cool down cycle. If you

want to start your stove again, you will need to press on the  button and then on the “ON/OFF” button . Your stove will only restart when the cool down cycle is completed.

**NOTE:** IF, AFTER PERFORMING ALL THE POSSIBLE SOLUTIONS MENTIONED IN THE FOLLOWING SECTION, YOU ARE STILL EXPERIENCING PROBLEMS WITH YOUR STOVE, CALL YOUR LOCAL DEALER OR A SERVICE TECHNICIAN AT (418) 908-8002. YOU CAN ALSO WRITE AN EMAIL TO: [tech@sbi-international.com](mailto:tech@sbi-international.com)

**NOTE:** IF YOU NEED TO CONTACT YOUR DEALER OR TECHNICAL SUPPORT, MAKE SURE TO HAVE THE MODEL OF YOUR STOVE AND THE SERIAL NUMBER ON HAND. (THEY CAN BE FOUND ON THE CERTIFICATION LABEL INSIDE THE HOPPER LID).

### 9.3.1 Blocked Flue

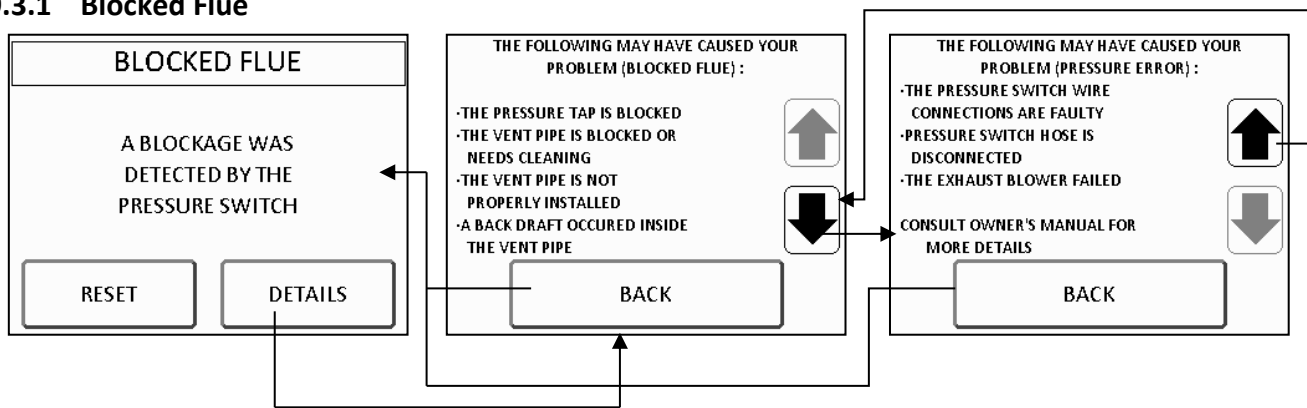

- ❖ **Pressure tap (located on the exhaust blower) is blocked.** Pull off the air hose from the exhaust blower pressure tap and from) pressure sensor tap. **WARNING: THE TUBE MUST ABSOLUTELY BE DISCONNECTED FROM BOTH ENDS AS TO NOT DAMAGE THE PRESSURE SENSOR.** Blow in the air tube. If air flows freely, the hose is fine. If air does not flow through the hose, use a thin wire to clear the blockage.
- ❖ **The flue is blocked or needs cleaning.** One of the following components is obstructed or blocked by ashes or by a foreign object; air intake shutter, combustion blower, burn pot, heat exchangers and exhaust channels, exhaust blower and or venting system. Refer to the maintenance section.
- ❖ **The flue is not properly installed.** Make sure the venting system meets the criteria in the installation section of this manual as well as the venting system manufacturer's instructions.
- ❖ **A back draft occurred inside the flue.** This can occur on a very windy day or if your venting system does not have a proper termination.
- ❖ **The pressure sensor wire connections are faulty or disconnected.** Make sure that the pressure sensor telecommunication wire connections do not cause a short-circuit or are not loose. Replace or reconnect wires if necessary.
- ❖ **The pressure sensor hose is disconnected.** Make sure the pressure sensor hose is well installed on the exhaust blower pressure tap and on the pressure. If not, reinstall it.
- ❖ **The exhaust or combustion blower failed.** Go to the troubleshooting page on the LCD screen and test the exhaust and the combustion blowers independently (see **Section 9.2 Testing Components**). If one of them does not work, make sure there is power and that blowers are well connected. If they still don't work, check fuse F4 and F5 on the control board. A defective fuse will be darkened or will have a broken filament. If the fuses are good, the combustion or exhaust blower is probably defective. Replace the faulty part.
- ❖ **Pressure sensor is defective.** Even if this is very rare, the pressure sensor could be defective. To test it, go to the troubleshooting page on the LCD (see **Section 9.2 Testing Components**). Start the exhaust blower. If the pressure switch square switches from the right column to the left column, it means the pressure sensor works. If not, the pressure sensor is defective and needs to be replaced.

### 9.3.2 No Fuel

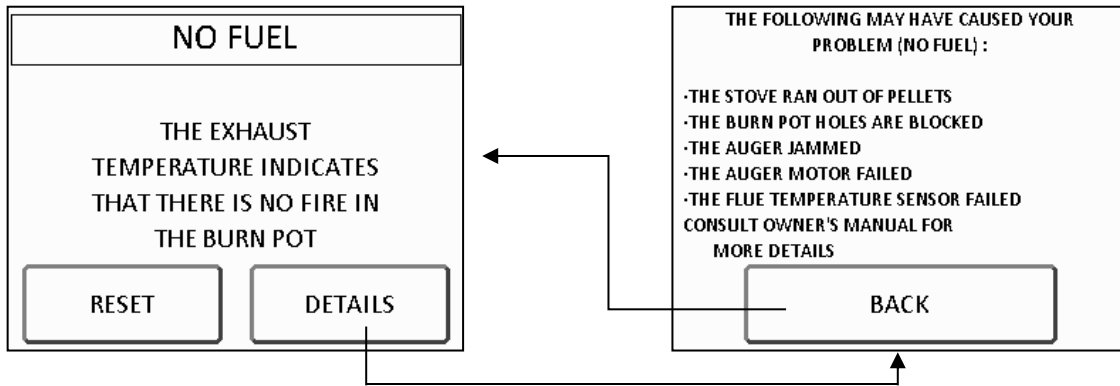

- ❖ **The stove ran out of pellets.** Refill the hopper. Press “Reset” then “ON.”
- ❖ **The burn pot holes are blocked.** Remove the burn pot and clean it thoroughly.
- ❖ **The auger is jammed or auger motor failed.** Go to the troubleshooting page on the LCD (see **Section 9.2 Testing Components**) screen and test auger motors. If one of the motors is not running check if motor is defective or if the auger is jammed.

#### HOPPER VALVE

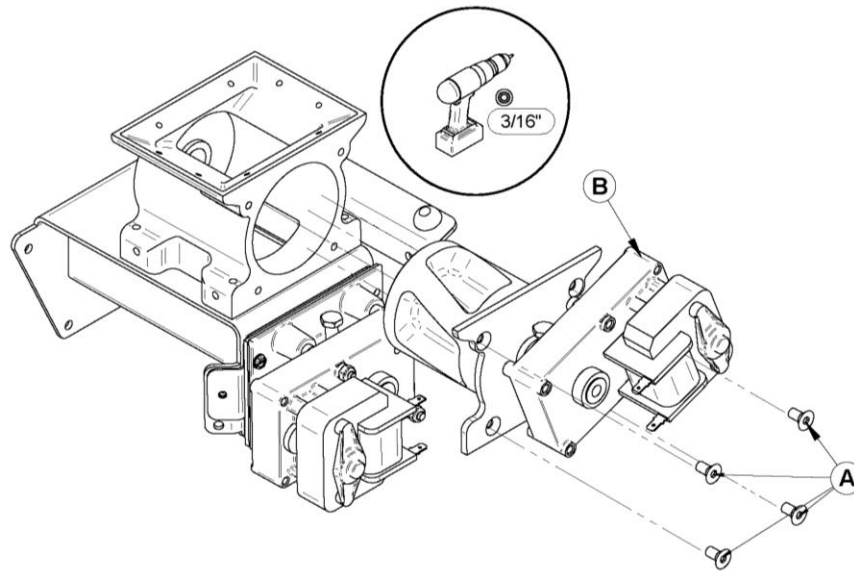

A	Screws
B	Valve and motor assembly

## BURN POT AUGER

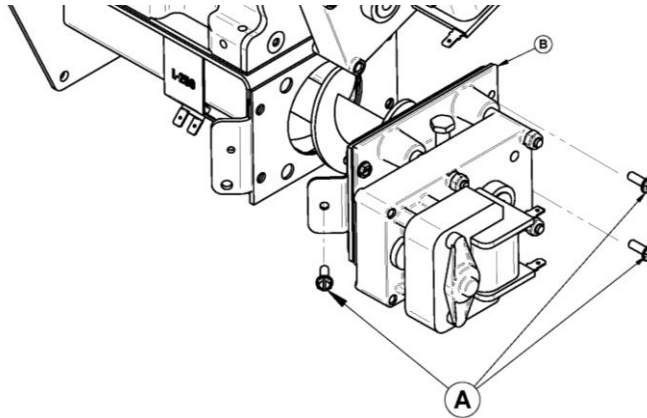

A	Screws
B	Auger and motor assembly
C	Gasket

**NOTE: IF THE HOPPER AUGER MOTOR FAILED OR THE HOPPER VALVE IS JAMMED, TO AVOID PELLET SPILLAGE, EMPTY THE HOPPER OF ITS CONTENTS BEFORE EXECUTING THE FOLLOWING TESTS.**

- If the auger motor is defective, check to make sure that electrical connections are not loose and check the fuses F2 and F6 on the control board. A defective fuse will be darkened or will have a broken filament. If the fuses are good, the auger motor may be jammed by an object.
- If the burn pot auger is jammed, remove it from its housing. Disconnect the motor and then remove the three screws on the steel plate that holds the auger shaft to the auger housing. To have an easier access, remove the rear panel for an easier access. Pull out the auger from the housing. Once the auger has been removed, make sure the auger is straight, that the surface is not damaged and there are no burrs, or broken welds. Remove any foreign material that may have caused the jam. Inspect the auger housing for signs of damage such as burrs, rough spots, or grooves cut into the metal that could have caused a jam. Clean the auger housing thoroughly to remove all pellet dust.
- If the hopper's rotary valve is jammed, empty the hopper's pellet contents completely to access the top of the rotary valve. Once accessible, make sure that no object, other than wood pellets, are found in the cavities of the rotary valve. Thereafter, if the rotary valve is still jammed pull it out from the housing. Disconnect the motor and then remove the four screws on the steel plate that holds the rotary valve to its housing. To have an easier access, remove the rear panel for an easier access. Pull out the auger from the housing. Once the valve has been removed, make sure that the surface is not damaged and there are no burrs. Remove any foreign material that may have caused the jam. Inspect the valve housing for signs of damage such as burrs, rough spots, or grooves cut into the metal that could have caused a jam. Clean the valve housing thoroughly to remove all pellet dust.
- If no object appears to block the auger, reconnect the electrical connections of the motor and turn on the stove. **BE CAREFUL NOT TO TAKE AN ELECTRIC SHOCK.** Test the motor using the "TROUBLESHOOTING" mode.

- ❖ **The flue temperature sensor failed.** The exhaust temperature probe (RTD) is a heat sensor located on the exhaust housing. Its function is to tell the control board that the stove has ignited properly by measuring the heat at the exhaust. When the stove is cold, check page 1 in the “TROUBLESHOOT” menu if the temperature displayed on the line “EXHAUST TEMP” displays a value equal to the ambient temperature in the room where the appliance is installed. If this is the case, turn on the stove and check the same temperature display. If after 10 minutes, the value has not increased despite the unit is in operation this means that the temperature sensor is disconnected or defective. If the temperature rises, the problem may be with the feed rate or pilot mode. Depending on many factors (ambient temperature, pellet quality, etc) the heat produced by the stove may not be sufficient to keep the exhaust temperature high enough. To resolve the situation increase feed rate (see **Section 6.1.6 Combustion Settings and Pilot Settings depending on Fuel Quality**).

### 9.3.3 Failed Ignition

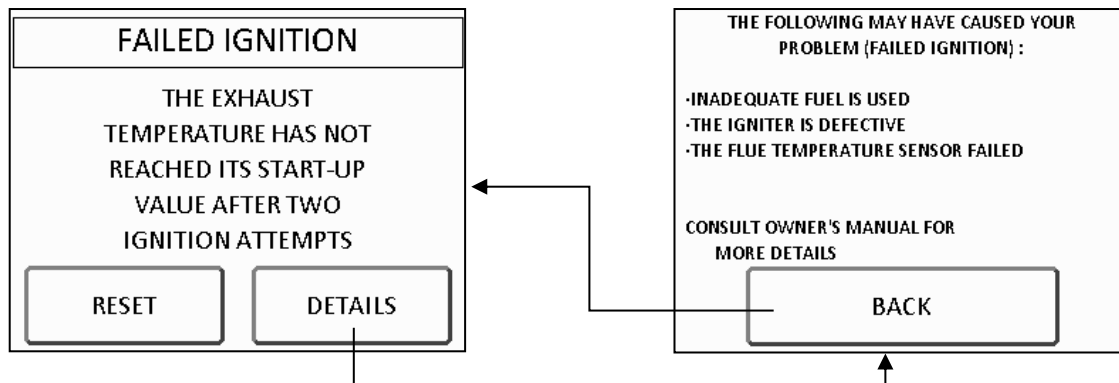

- ❖ **Inadequate fuel is used.** Remove the burn pot, make sure that all openings are clear and check that no ash has filled the tube around the igniter. Refer to the maintenance section. Also, make sure that recommended fuel is used (see **Section 5.2.1 Proper Fuel**).
- ❖ **The igniter is defective.** Go to the troubleshooting page (see **Section 9.2 Testing Components**) and follow instructions for component check. Test the igniter to see if it glows. It should take no longer than two minutes. If it does not glow red, check the wiring and the F3 fuse. If the wiring is properly connected and the fuse is good, disconnect the igniter and check its resistance (ohms,  $\Omega$ ) with a multimeter. If the value is near zero, replace the igniter.
- ❖ **The flue temperature sensor failed.** The exhaust temperature probe (RTD) is a heat sensor located on the exhaust housing. Its function is to tell the control board that the stove has ignited properly by measuring the heat at the exhaust. When the stove is cold, check page 1 in the “TROUBLESHOOT” menu if the temperature displayed on the line “EXHAUST TEMP” displays a value equal to the ambient temperature in the room where the appliance is installed. If this is the case, turn on the stove and check the same temperature display. If after 10 minutes, the value has not increased despite the unit is in operation this means that the temperature sensor is disconnected or defective. If the temperature rises, the problem may be with the feed rate or pilot mode. Depending on many factors (ambient temperature, pellet quality, etc) the heat produced by the stove may not be sufficient to keep the exhaust temperature high enough. To resolve the situation increase feed rate (see **Section 6.1.6 Combustion Settings and Pilot Settings depending on Fuel Quality**).

### 9.3.4 Defective Igniter Fuse

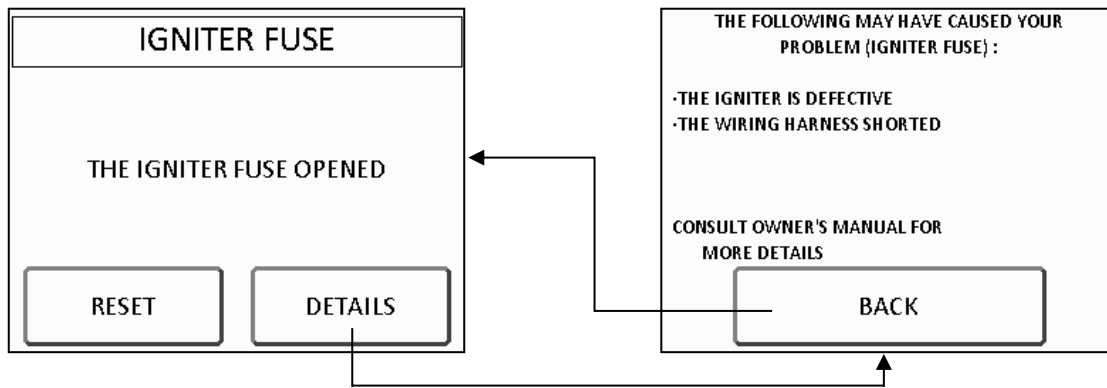

- ❖ **The igniter is defective:** Test the resistance (ohms,  $\Omega$ ) with a multimeter. If the value is near zero, replace the igniter and the F3 fuse.
- ❖ **The wiring harness shorted.** Inspect the wiring and replace any defective wire and or connector. Make sure the wires are not shorted to the stove frame. Locate the fuse F3 on the control board and replace it. Go to the troubleshooting page (see **Section 9.2 Testing Components**) and follow instructions for component check. Test the igniter to see if it glows. It should take no longer than two minutes.

### 9.3.5 Auger Fuse

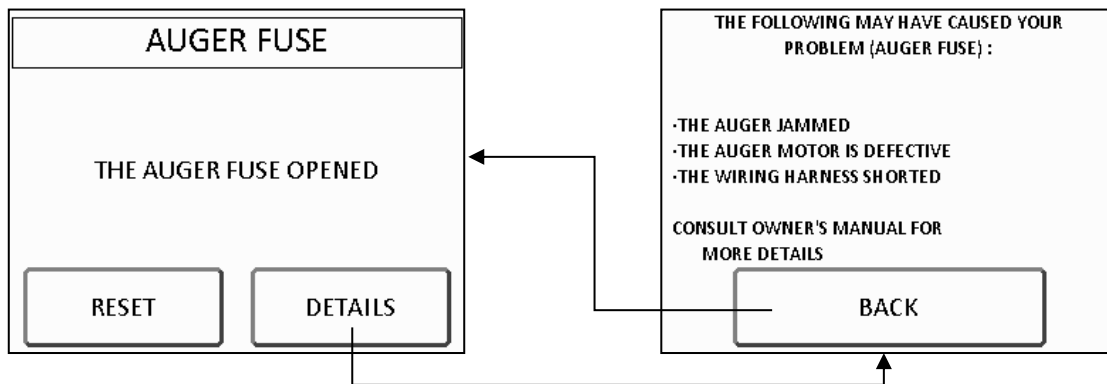

- ❖ **The rotary valve or auger is jammed or gear motor failed.** Go to the troubleshooting page (see **Section 9.2 Testing components**) on the LCD screen and test both gear motors. If one of the motors is not running check if motor is defective or if the pot auger or rotary valve is jammed.

**NOTE: IF THE HOPPER GEAR MOTOR FAILED OR THE ROTARY VALVE IS JAMMED, TO AVOID PELLET SPILLAGE, EMPTY THE HOPPER OF ITS CONTENTS BEFORE EXECUTING THE FOLLOWING TESTS.**

- If the gear motor is defective, check to make sure that electrical connections are not loose and check the fuses F2 and F6 on the control board. If the fuses are good, remove the faulty gear motor from its auger housing and retest the motor separately still using the troubleshooting test mode. Make sure the hopper lid is closed. If the motor works, the auger may be jammed by a foreign object. If no signs of blockage are found, call your dealer or a service technician to perform a complete testing.

- If the pot auger is jammed, remove it from its housing (see **Section 11.4: Auger replacement**). Once the auger has been removed, make sure it is straight and there are no metal flaws, burrs, or broken welds. Remove any foreign material that may have caused the jam. Inspect the auger housing for signs of damage such as burrs, rough spots, or grooves cut into the metal that could have caused a jam. Clean the auger housing thoroughly to remove all pellet dust.
- If the hopper's rotary valve is jammed, empty the hopper's pellet contents completely to access the top of the rotary valve. Once accessible, make sure that no object, other than wood pellets, are found in the cavities of the rotary valve. Thereafter, before putting back wood pellets, close the hopper lid and go to the "TROUBLESHOOT" page of the LCD interface to test the gear motor 1. If the rotary valve does not seem to be stuck and the gear motor is working, contact your dealer or customer service to run a complete test.

❖ **The wiring harness shorted.** Make sure the auger motor wiring is properly connected and not shorted.

### 9.3.6 Unit Overheat

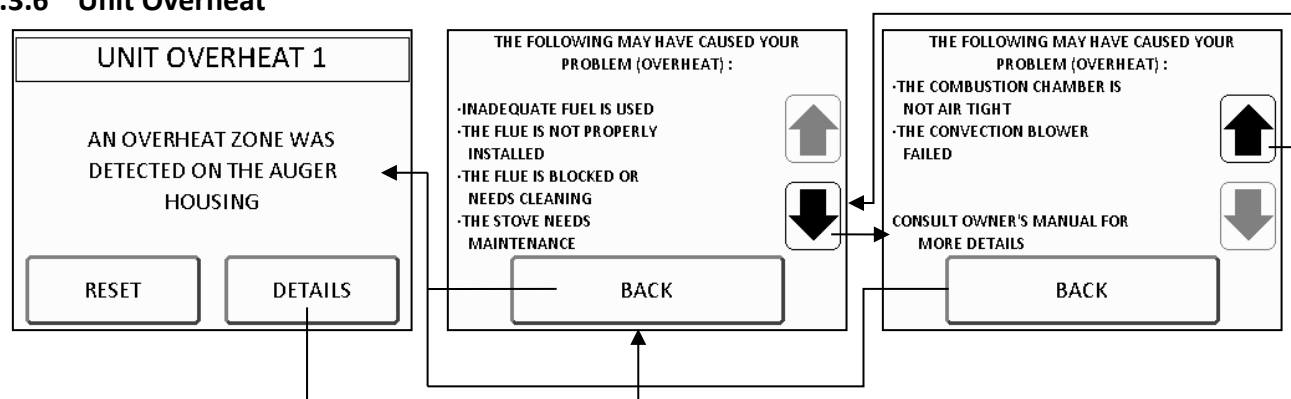

- ❖ **Inadequate fuel is used.** Remove the burn pot, make sure that all openings are clear and check that no ash has filled the tube around the igniter. Refer to the maintenance section. Also, make sure that the recommended fuel is used (see **Section 5.2.1 Proper Fuel**).
- ❖ **The flue is not properly installed.** Make sure the venting system meets the criteria in the **Section 4: Venting System** as well as the venting system manufacturer's instructions.
- ❖ **The flue is blocked or needs cleaning.** One of the following components is obstructed or blocked; air intake shutter, combustion blower, burn pot, heat exchangers and channels, exhaust blower and or venting system. Refer to **Section 8: Maintenance**.
- ❖ **The stove needs maintenance.** Refer to **Section 8: Maintenance**.
- ❖ **The burn pot is not installed properly.** Make sure the burn pot is installed correctly (see **Section 8.1.4: Cleaning the Burn Pot**).
- ❖ **The baffle is not installed properly or holes may be blocked.** Make sure the baffle is well installed and the lock is in place. Make sure the holes are clear. (see **Section 8.1.2: Cleaning the Baffle, the Heat Exchanger and the Combustion Chamber**).
- ❖ **The convection blower is defective.** Go to the troubleshooting page on the LCD screen and test the convection blower (see **Section 9.2 Testing Components**).
- ❖ **The convection blower needs maintenance.** Carefully clean blower housing and make sure blower louvers are not blocked.

**NOTE: IF THE CODE APPEARS MORE THAN THREE TIMES, THE LCD SCREEN WILL LOCK ITSELF UP.**

**THIS PELLET STOVE IS EQUIPED WITH MULTIPLE DEVICES TO ENSURE YOUR SAFETY. IF A WARNING ERROR CODE STOPS YOUR STOVE ON SEVERAL OCCASIONS, IT IS MORE THAN LIKELY THAT THE STOVE DOES NOT EXHAUST PROPERLY.**



**Before resetting the PC-board displaying an error code, do a COMPLETE stove maintenance as described in this manual.**



### **For an Overheat Code**



- Service the stove **COMPLETELY** as described in this manual. See section 8: Maintenance.
- Verify the venting system and all other components mentioned above.

**ONCE THE MAINTENANCE DONE, FOLLOW THESE INSTRUCTIONS**

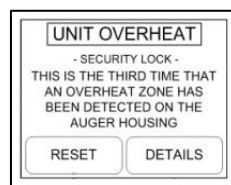

After 3 attempts, press restart and then enter the following code

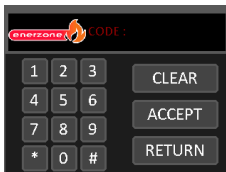

**999333555** and press accept. The system will reset.

### **9.3.7 Hopper Lid Open**

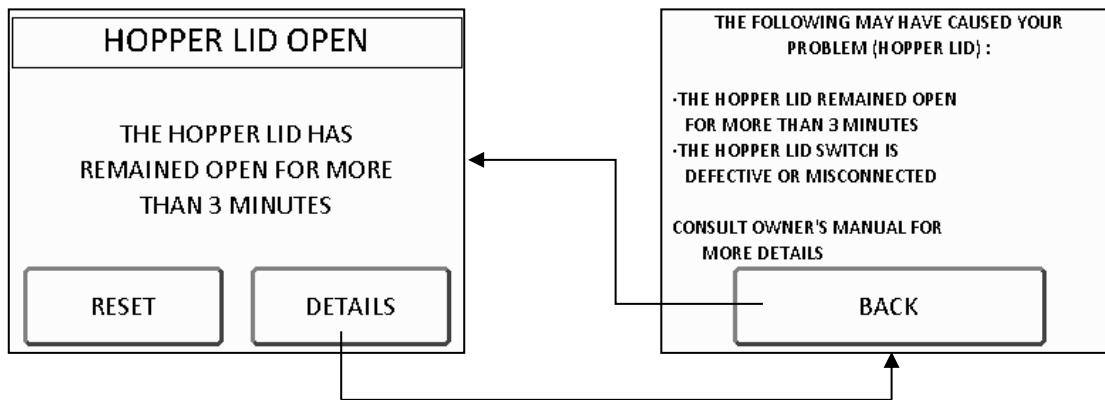

- ❖ **The hopper lid remained open for more than 3 minutes.** As a security measure, the auger stops turning and feeding pellets as soon as the hopper lid opens. It will resume normal operation as soon as the hopper lid is closed. If the hopper lid stays open for more than 3 minutes, the stove will stop.
- ❖ **The hopper lid safety switch is faulty or disconnected.** Make sure that the switch wiring is properly connected. If it is, the hopper switch may be faulty. Follow steps in the troubleshooting page (see **Section 9.2 Testing Components**) and verify the proper function of the safety switch. Replace if necessary.

### 9.3.8 Power Loss

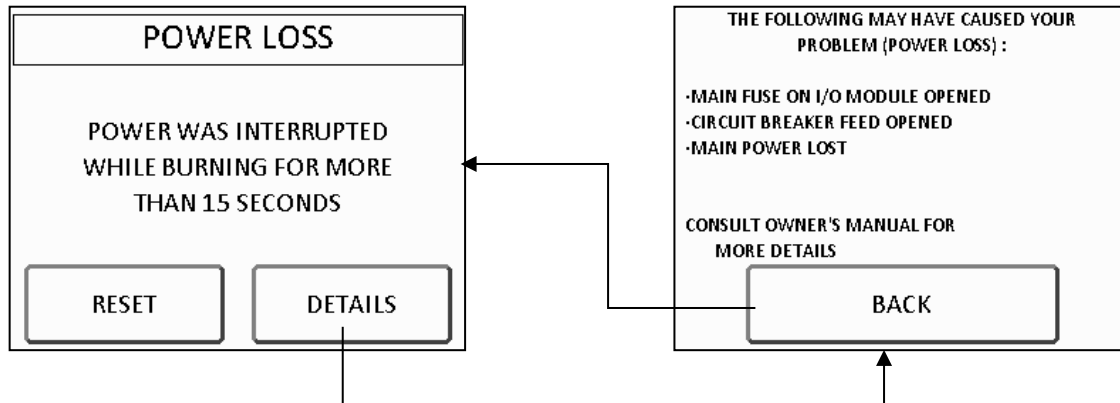

- ❖ **Power was interrupted while the stove was functioning.** After the cool down cycle, the stove will restart using the last settings. Press “RESET” to go back to the Main Status Page.

**Note:** For a short power failure (less than 5 seconds), the stove will continue to function at the selected speed.

### 9.3.9 Smoke Smell

- ❖ **Venting system leaks.** Inspect all vent connections. This is a pressurized venting system. All vent connector joints must be sealed and fastened in accordance with the pellet vent manufacturer's instructions to ensure consistent performance and avoid smoke and ash spillage (see **Section 4.5.1: Installation Warnings, Cautions and Recommendations Reminder**).
- ❖ **Worn gaskets.** Gaskets may be allowing smoke spillage (doors, clean out traps, etc). Make sure that all gaskets are in good condition and replace them with original parts if necessary. Make sure the door is well adjusted (see **Section 8.1.9 Door Adjustment**).
- ❖ **Negative pressure.** A faint wood-burning odor during ignition or shut down is normal. Although, if this increases beyond what is considered normal or if you notice an unusual soot build-up on walls or furniture, check your venting system carefully for leaks and make sure all gaskets are in good condition. The stove exhaust blower produces a negative pressure in the room. It draws air from the inside of the room, through the stove and then outdoors. In the same manner, other appliances can also create a larger negative pressure. In this case, as the air naturally flows from a high pressure point to a low pressure point, a larger negative pressure can draw smoke from the inside of the stove into the room. The stove can also be affected by other mechanical ventilation systems, causing the same effect as mentioned previously. Using a fresh air intake will prevent negative pressure (see **Appendix E: Combustion Air supply**). Also, make sure the recommended maintenance schedule has been followed.

### 9.3.10 Combustion Air Starvation

- ❖ **Venting system is dirty.** Refer to **Section 8: Maintenance**.
- ❖ **The flue is not properly installed.** Make certain the venting system meets the criteria in the installation section of this manual as well as the venting system manufacturer's instructions.
- ❖ **Inadequate fuel is used.** Remove the burn pot, make sure that all openings are clear and check that no ash has filled the tube around the igniter. Refer to **Section 8: Maintenance**. Also, make sure that recommended fuel is used (see **Section 5.2.1 Proper Fuel**) and settings are adjusted to the type of pellets that are being used (see **Section 6.1.5 Adjusting the Combustion Level (Heat Output)**).
- ❖ **Air intake channel is restricted.** Visually inspect the air intake channel that leads to the burn pot for foreign material. Make sure that the air-intake shutter is functional and free of any obstruction.
- ❖ **The combustion/exhaust blower failed.** Go to the troubleshooting page on the LCD screen and test the combustion and the exhaust blowers independently (see **Section 9.2 Testing Components**). If one of them does not function, make sure there is power and that the blowers are properly connected. If they still don't work, check fuse F4 and F5 on the control board. A blown fuse will be darkened or will have a broken filament. If the fuses are in good condition, the combustion or exhaust blower is probably defective; Replace the faulty part.

### 9.3.11 The LCD Touch Screen Does Not Lightup.

- ❖ **There is no electrical current going to the stove.** Check if the stove is connected and if there is current in the wall outlet. Check if the F7 fuse is blown. Replace it if necessary.
- ❖ **TELCO wire is defective or not connected properly.** Convection blower, combustion blower, exhaust blower and burn pot auger will start but the stove will beep continuously and the LCD touch screen will remain black. Check connection and change wire, if necessary.
- ❖ **The temperature of the screen is below zero.** When the screen is exposed to temperatures too cold, the liquid crystals may not function properly which causes a loss of communication. This situation may occur in cases where the unit has arrived from outside by a carrier or is subjected to a room temperature too low as in an unheated cottage or a very cold garage.

# 10 WIRING DIAGRAM

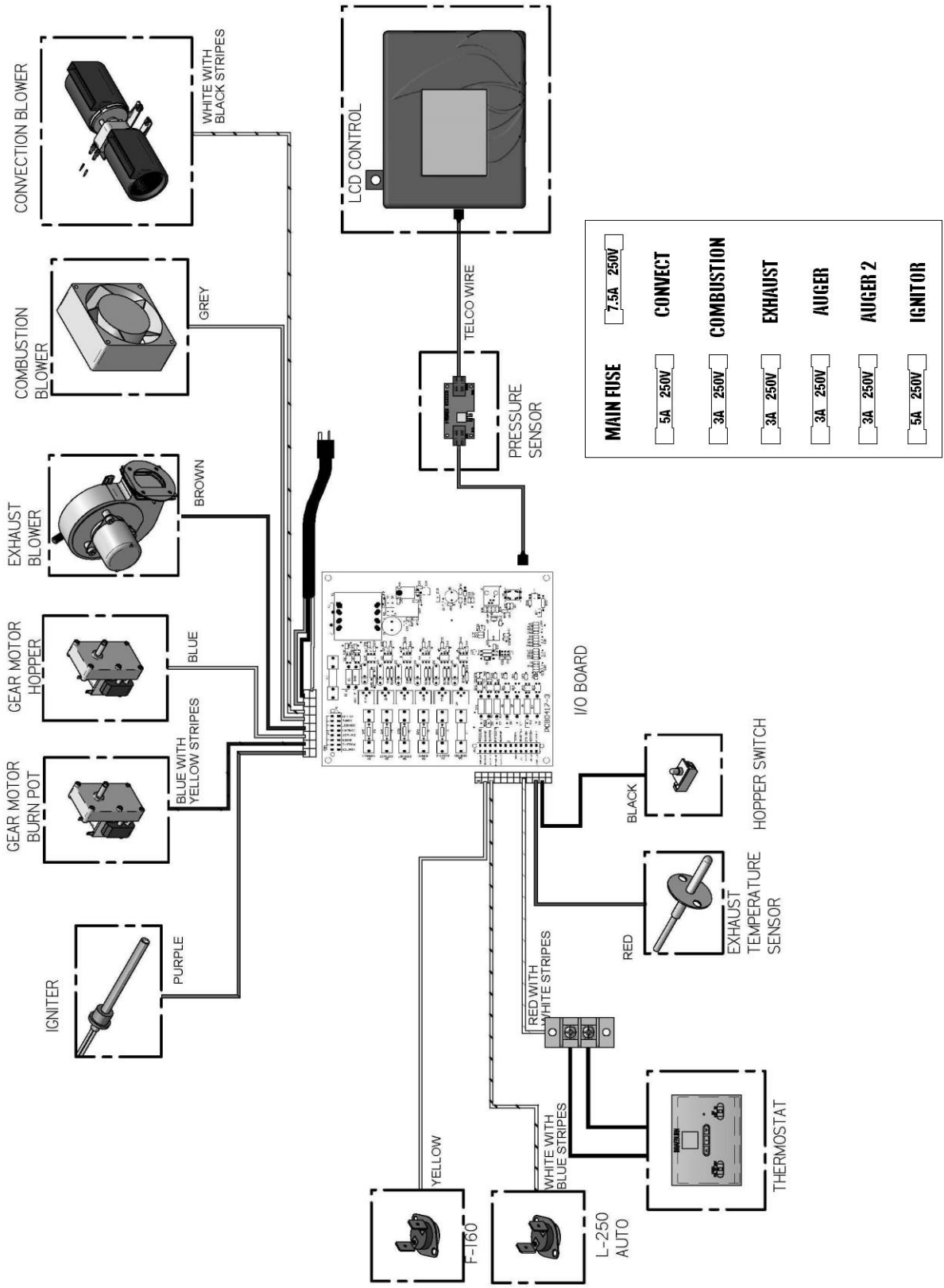

## 11 ACCESS TO FUSES

**WARNING: UNPLUG THE STOVE BEFORE CHANGING THE FUSES.**

All fuses are located inside the stove on the main electronic board. The main board is located on the right hand side of your stove. Unplug your stove, remove the right hand side decorative panel. Next, remove the two screws holding the panel and rotate the panel.

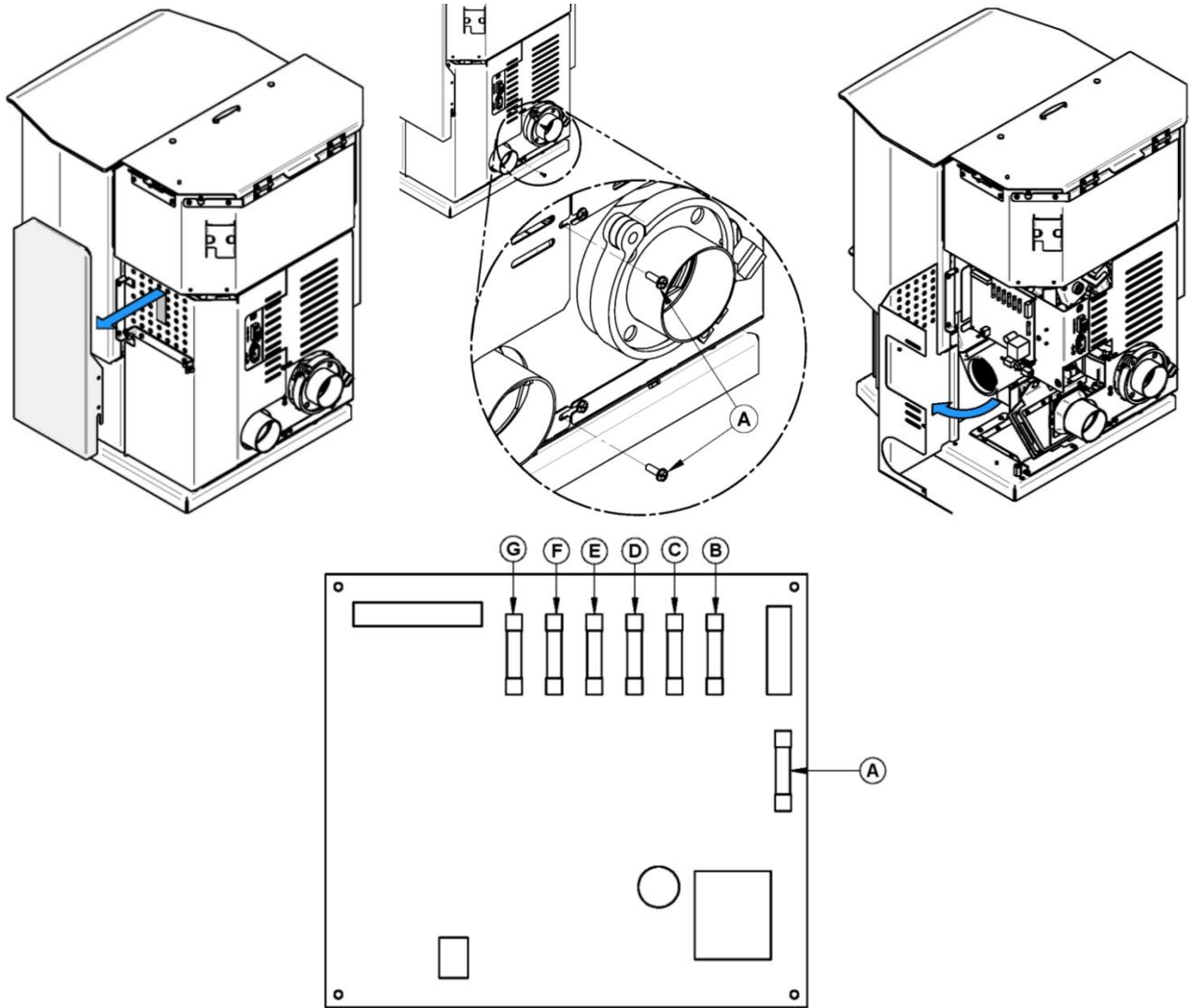

LETTER	FUSE FUNCTION	AMPERAGE
A	MAIN BOARD FUSE	7.5A
B	CONVECTION BLOWER	5A
C	COMBUSTION BLOWER	3A
D	EXHAUST BLOWER	3A
E	TOP AUGER #1	3A
F	BOTTOM AUGER #2	3A
G	IGNITOR	5A

## 12 COMPONENTS LOCATION

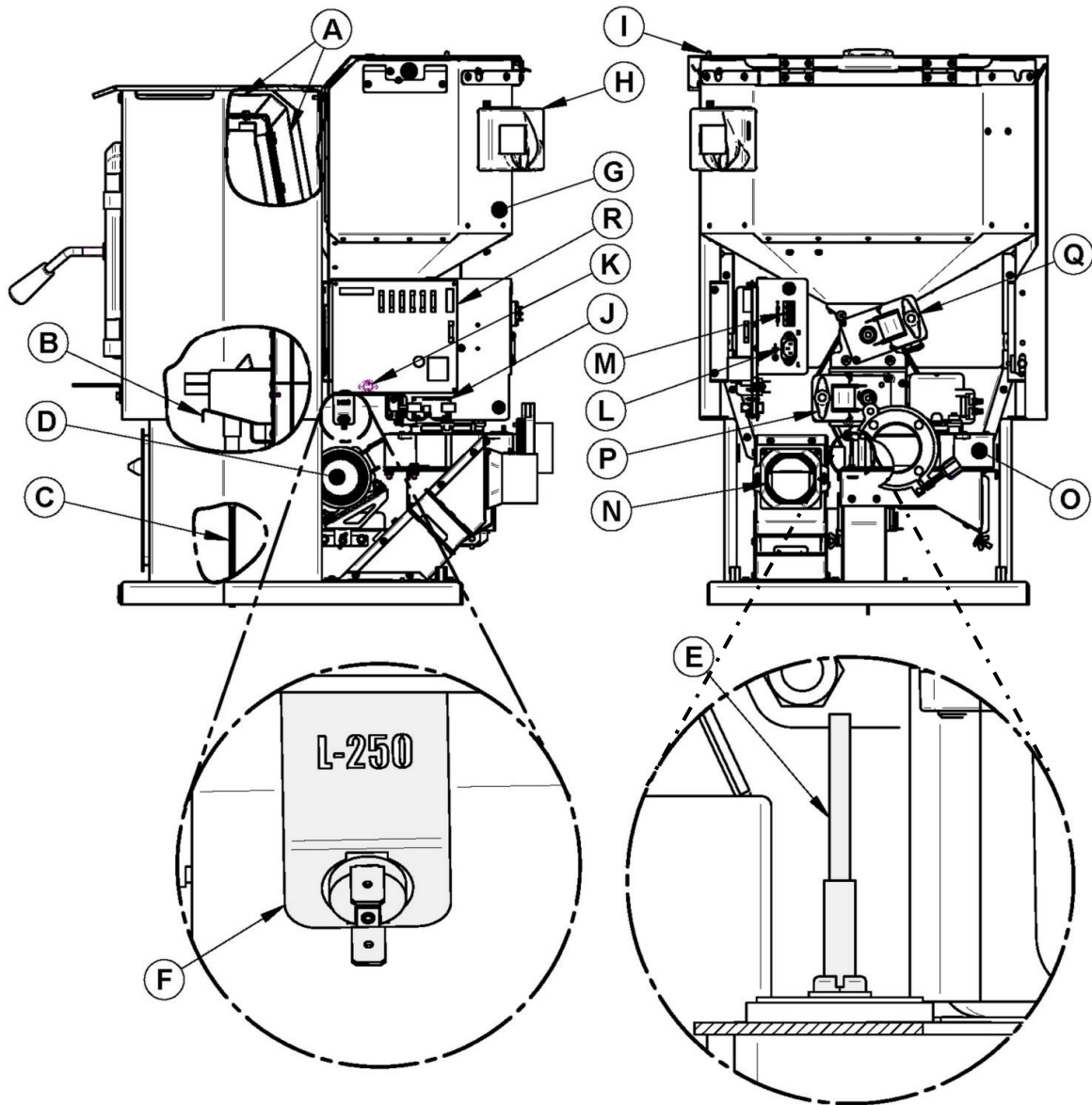

LETTER	COMPONENTS	LETTER	COMPONENTS
A	HEAT EXCHANGER TUBES	J	PRESSURE SWITCH
B	BURN POT	K	F-160 THERMAL SWITCH
C	IGNITOR	L	POWER CORD RECEPTACLE
D	CONVECTION BLOWER	M	THERMOSTAT TERMINAL BLOCK
E	THERMISTOR	N	COMBUSTION BLOWER/FRESH AIR INTAKE
F	L-250 THERMAL SWITCH	O	EXHAUST BLOWER
G	HOPPER	P	BOTTOM AUGER #2
H	TOUCH SCREEN CONTROL PANEL	Q	TOP AUGER #1

I	HOPPER SAFETY SWITCH	R	PC BOARD
---	----------------------	---	----------

## 13 BLOWER REPLACEMENT

### 13.1 Convection blower

Before disconnecting the wire harness from the convection fan assembly, take note which wire goes where.

1. Remove the decorative panel on the right hand side. Then, Remove the two screws **(A)** that hold the panel at the back of the stove. Open and lift the panel to take it off the stove.

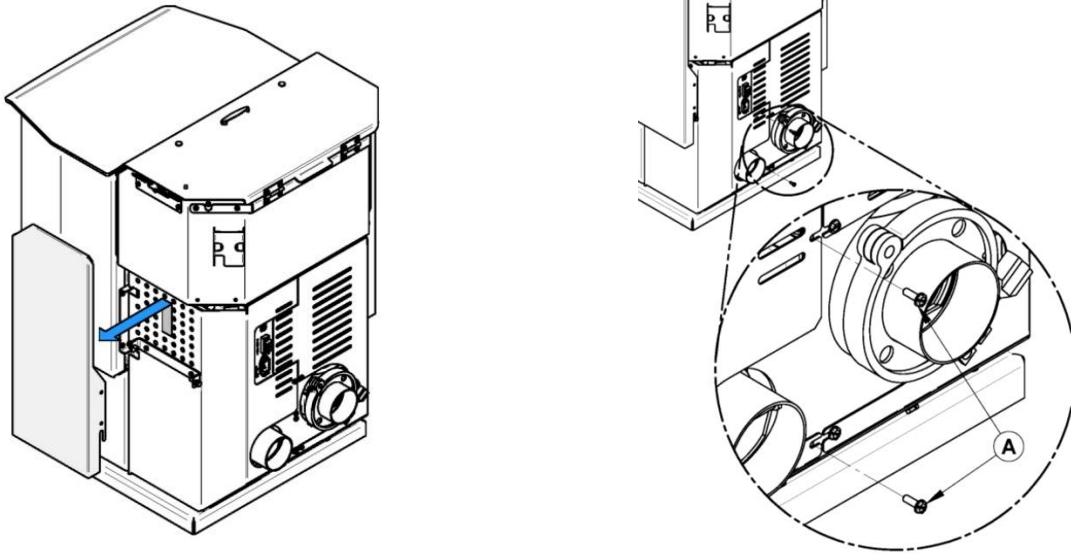

2. Remove the wing nut **(I)** that holds the convection blower **(K)** in place. Pull on the blower to take it out of the stove.

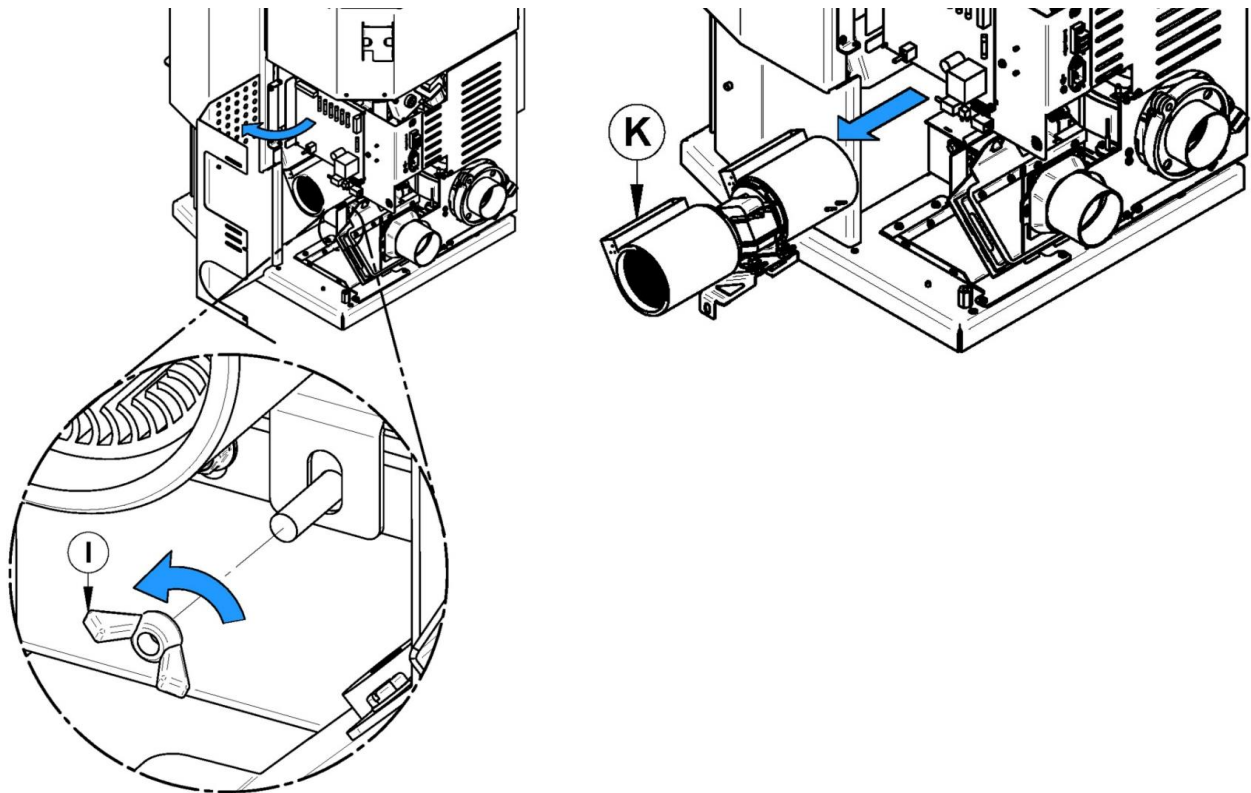

## 13.2 Combustion blower

1. Remove the decorative panel on the right hand side. Then, Remove the two screws **(A)** that hold the panel at the back of the stove. Open and lift the panel to take it off the stove.

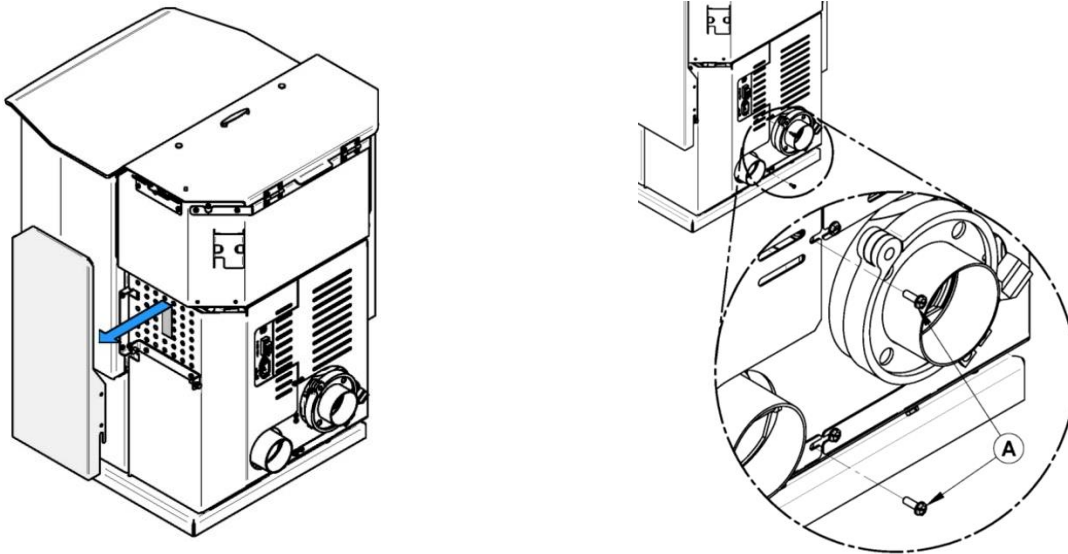

Unlatch the clamps **(C)**. Remove the backdraft shutter **(G)** and the gasket **(D)**. Pull the combustion blower **(F)** and unplug the wire connector from the harness. Remove the plug **(E)** of the blower.

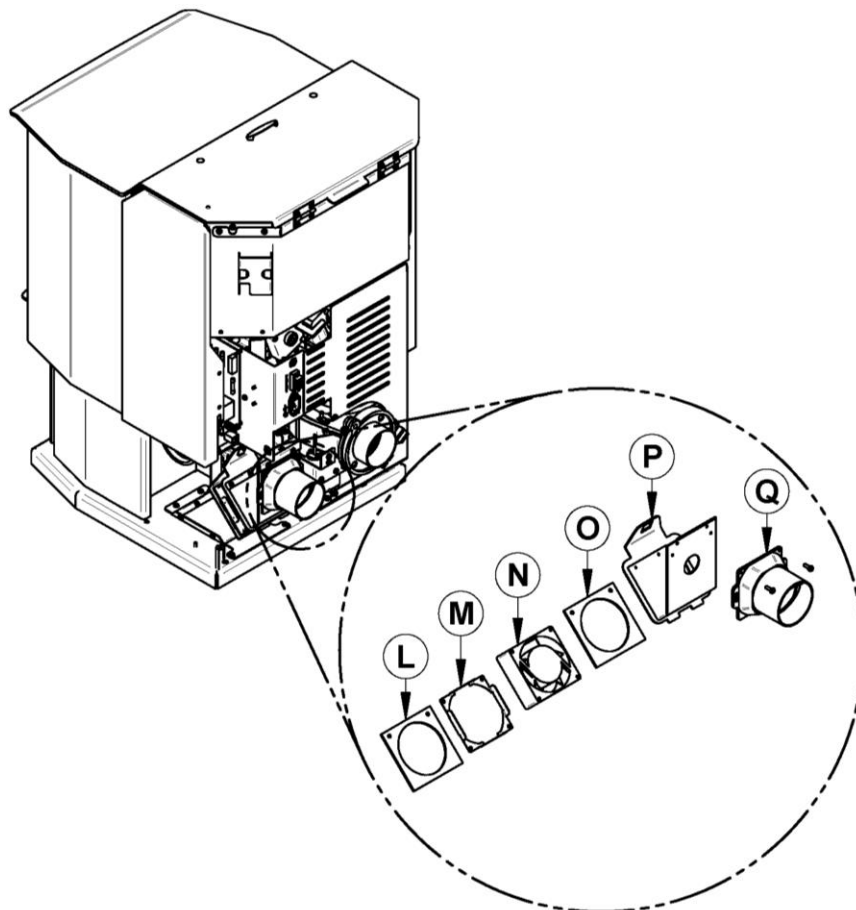

### 13.3 Exhaust blower

1. Remove the decorative panel on the right hand side. Then, Remove the two screws **(A)** that hold the panel at the back of the stove. Open and lift the panel to take it off the stove.

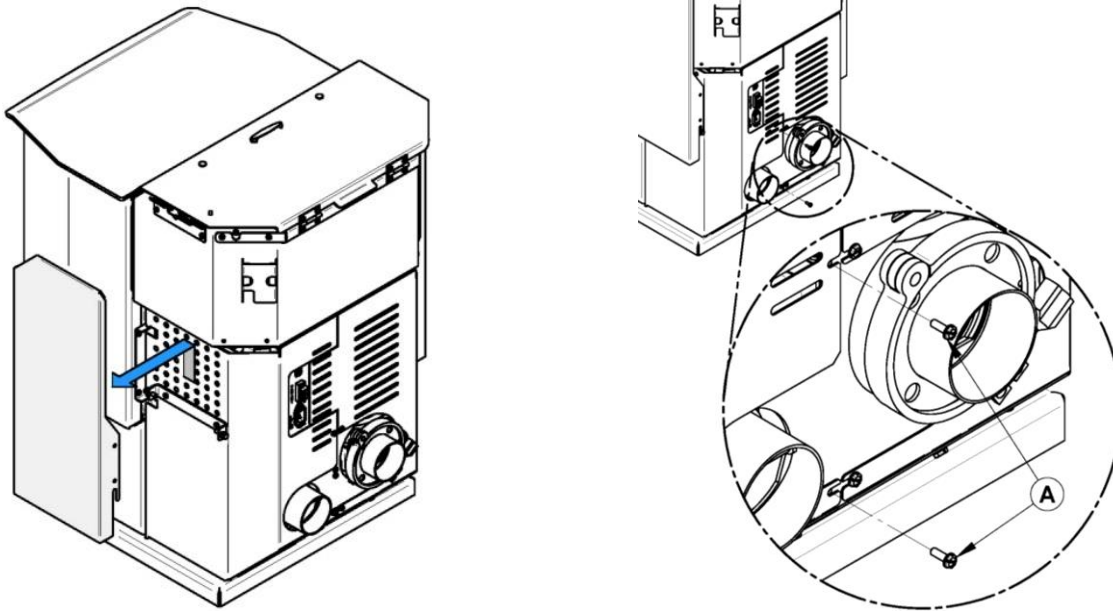

2. Remove the decorative panel on the left hand side. Then, Remove the two screws **(A)** that hold the panel at the back of the stove. Open and lift the panel to take it off the stove.

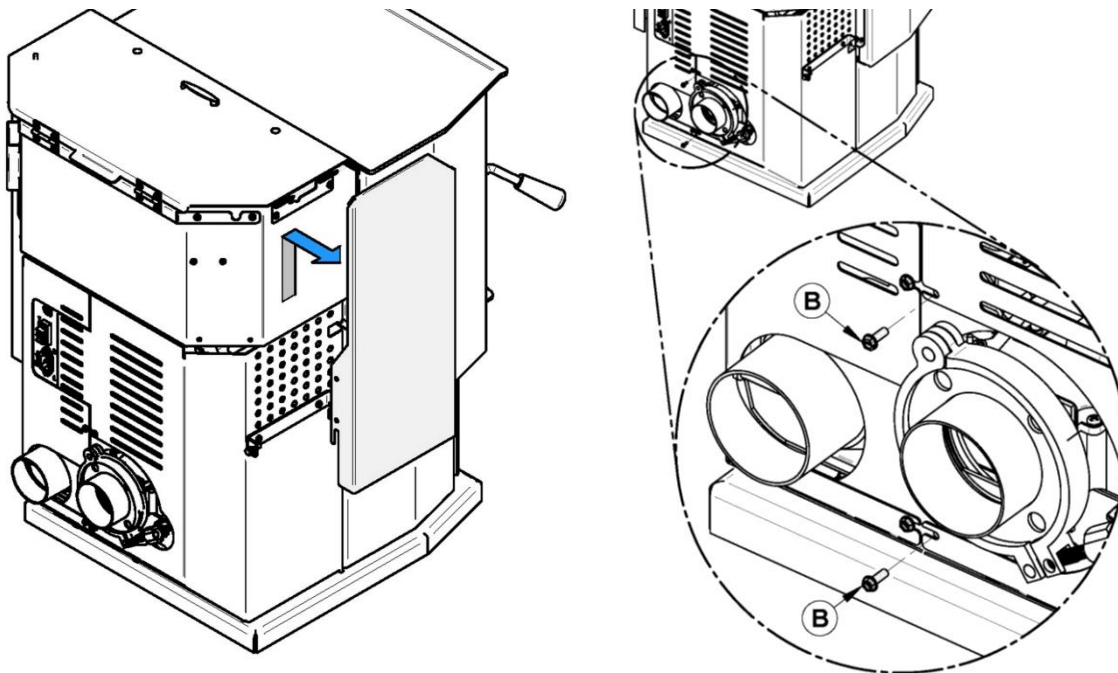

3. Open the left panel and lift it to take it out of the stove **(1)**. Remove the exhaust collar **(R)** from the flue collar **(2)**.

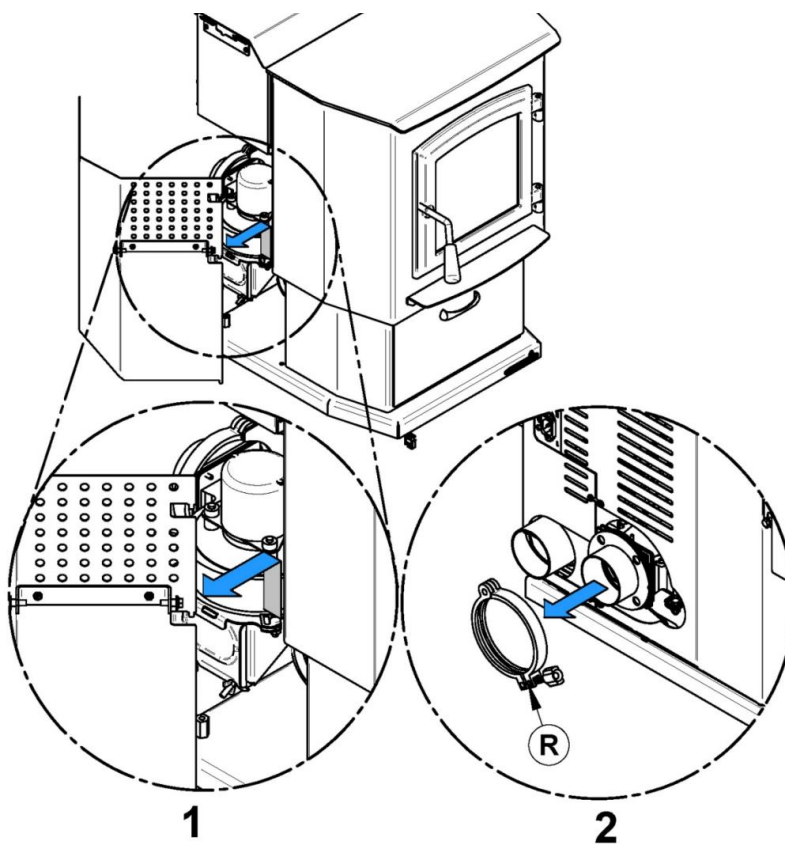

4. Remove the 3 bolts that hold the exhaust motor in place and pull the exhaust motor out of the stove.

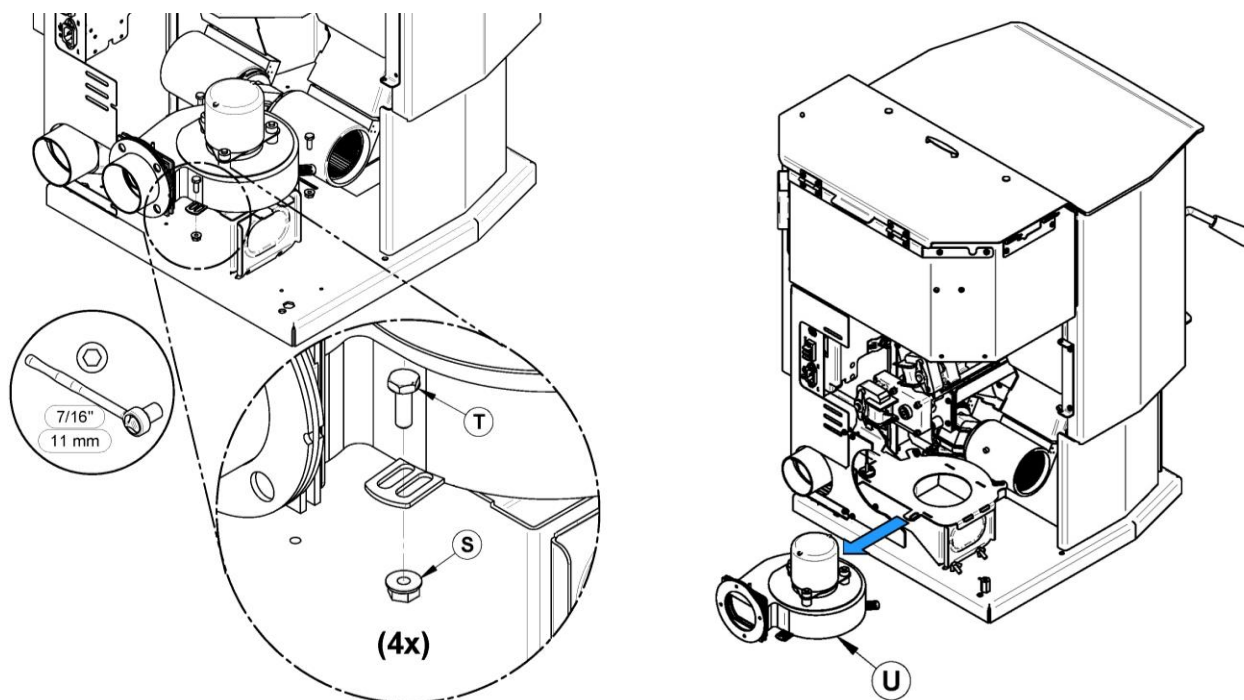

## 14 L-250 AND F-160 THERMAL SWITCH REPLACEMENT

Both thermal switch can be replaced the same way :

1. Remove both retaining screws **(A)** holding the thermal switch support bracket.
2. Remove both retaining screws **(B)** holding the thermal switch.
3. Remove the faulty thermal switch. Replace new thermal switch **(C)** underneath the bracket by means of 2 screws **(B)**.

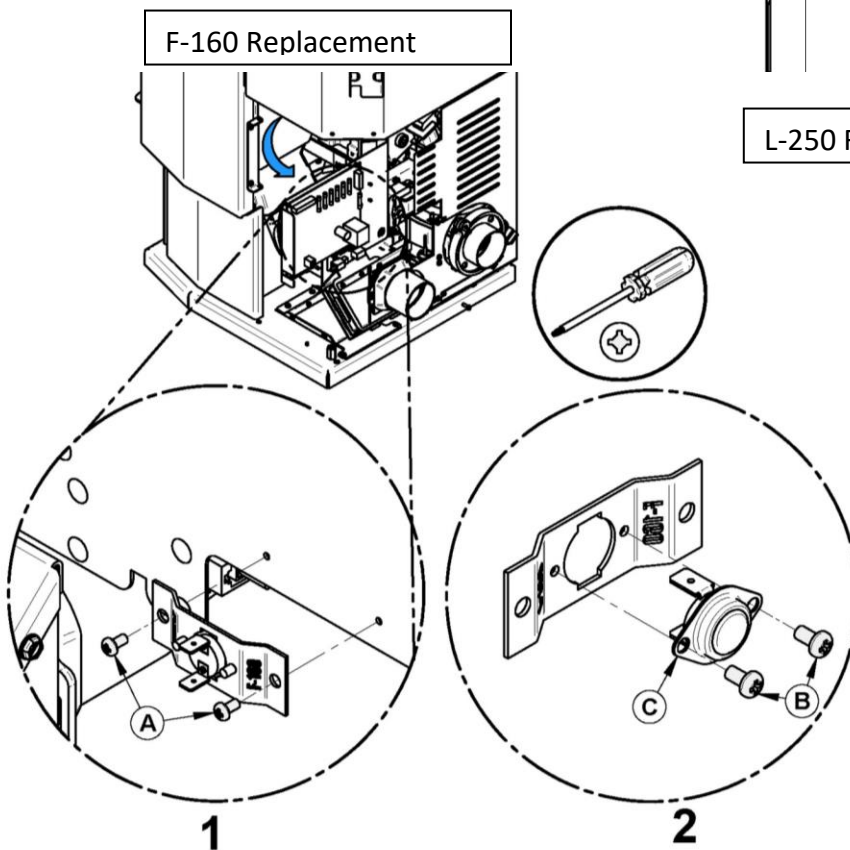
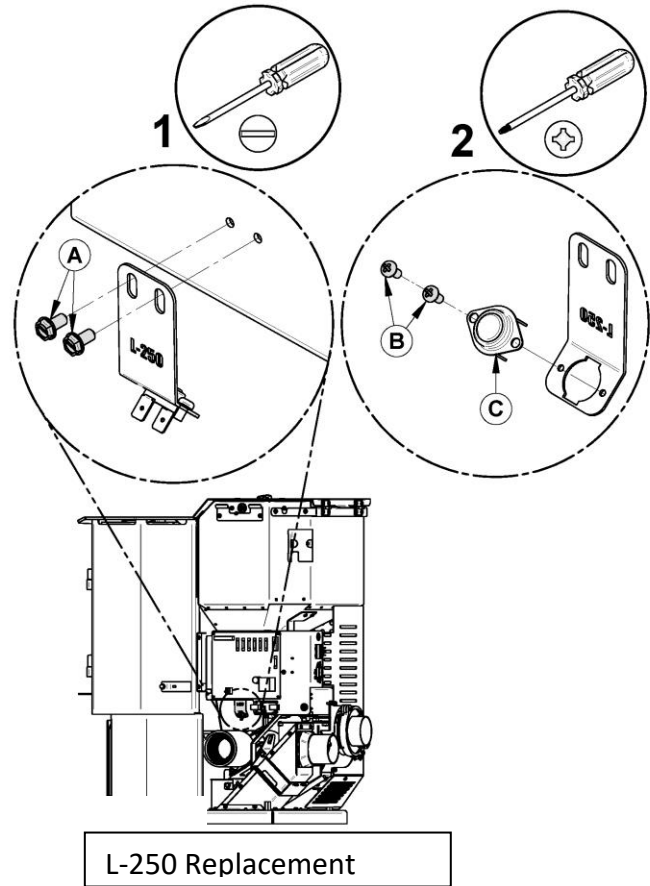

# 15 EXPLODED VIEW AND REPLACEMENT PARTS

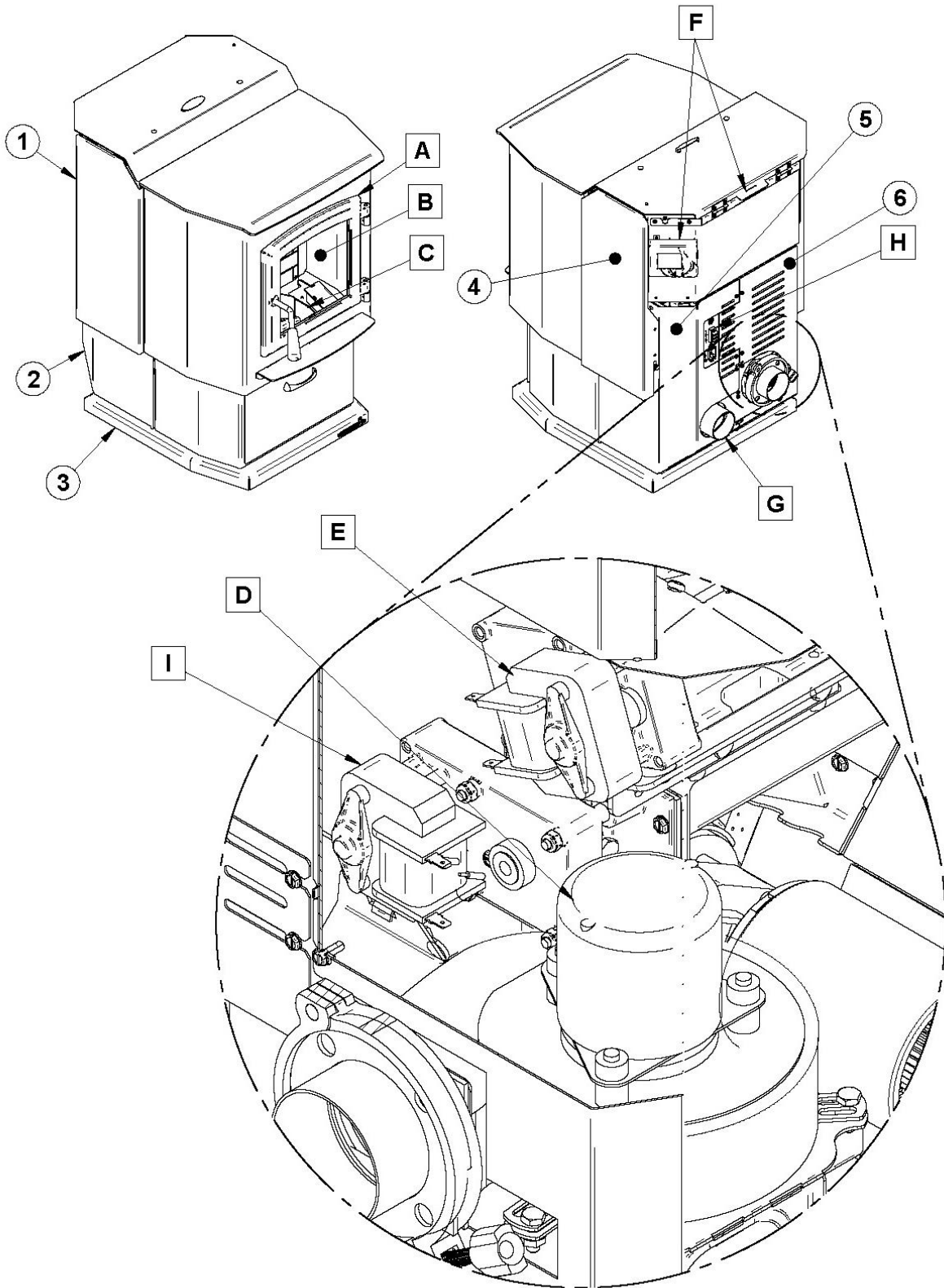

# SECTION A

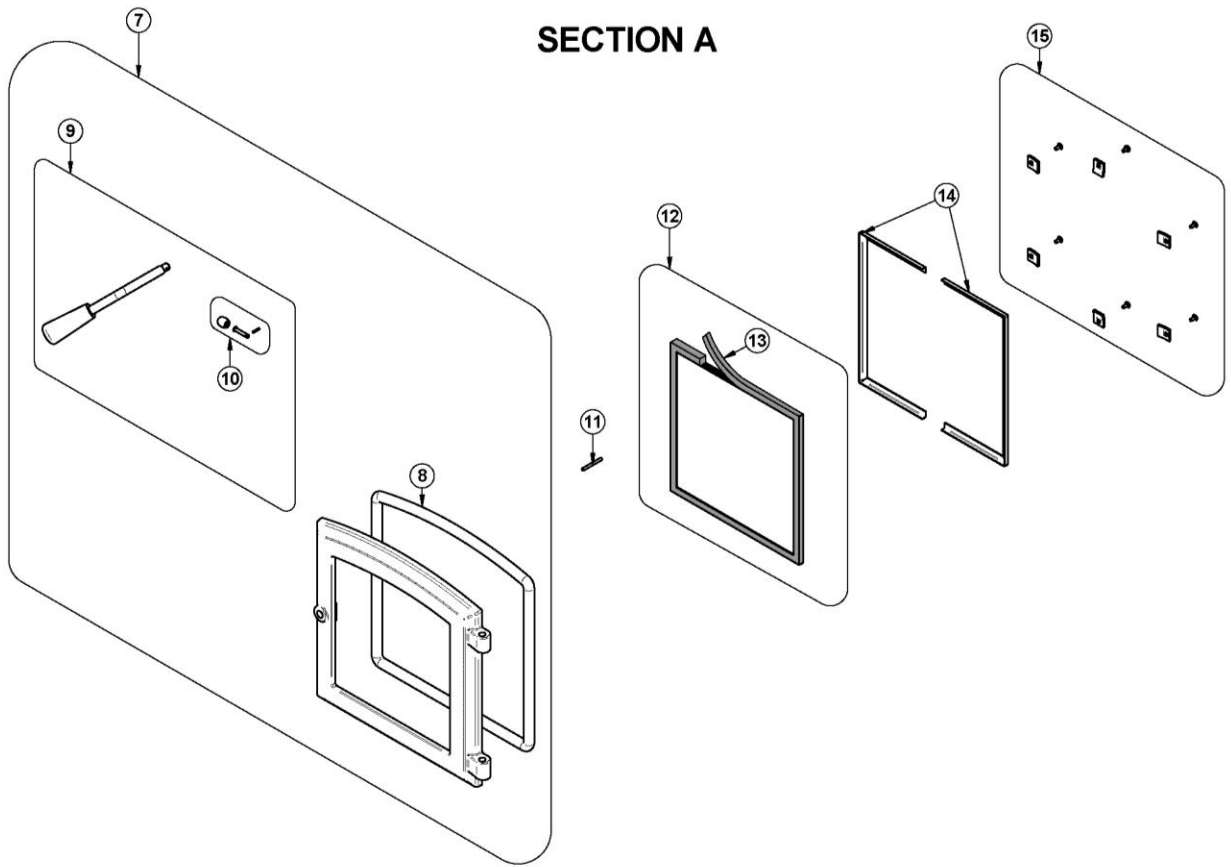

## SECTION B

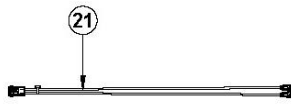
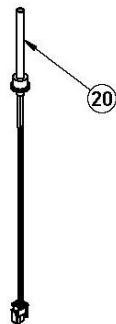
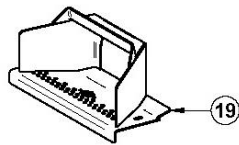
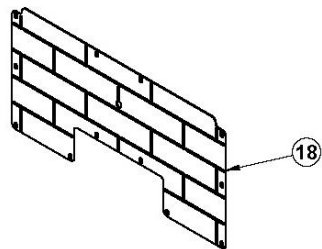
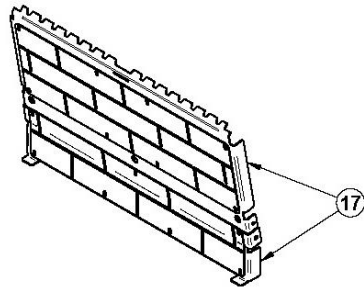
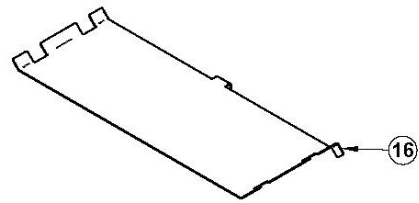

## SECTION C

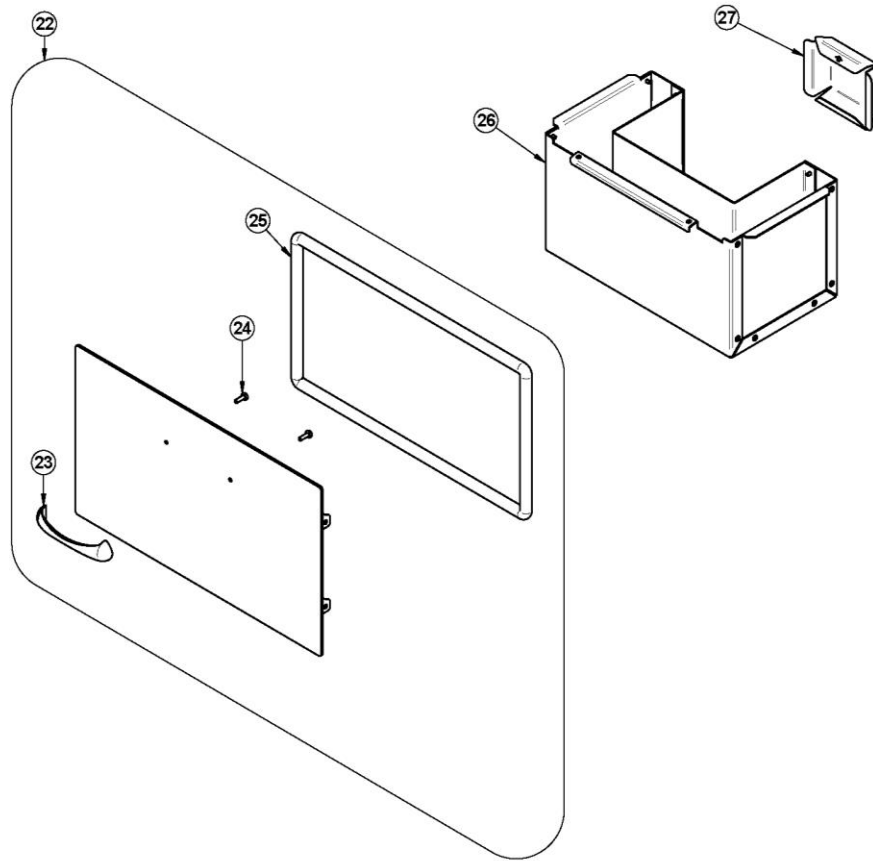

## SECTION D

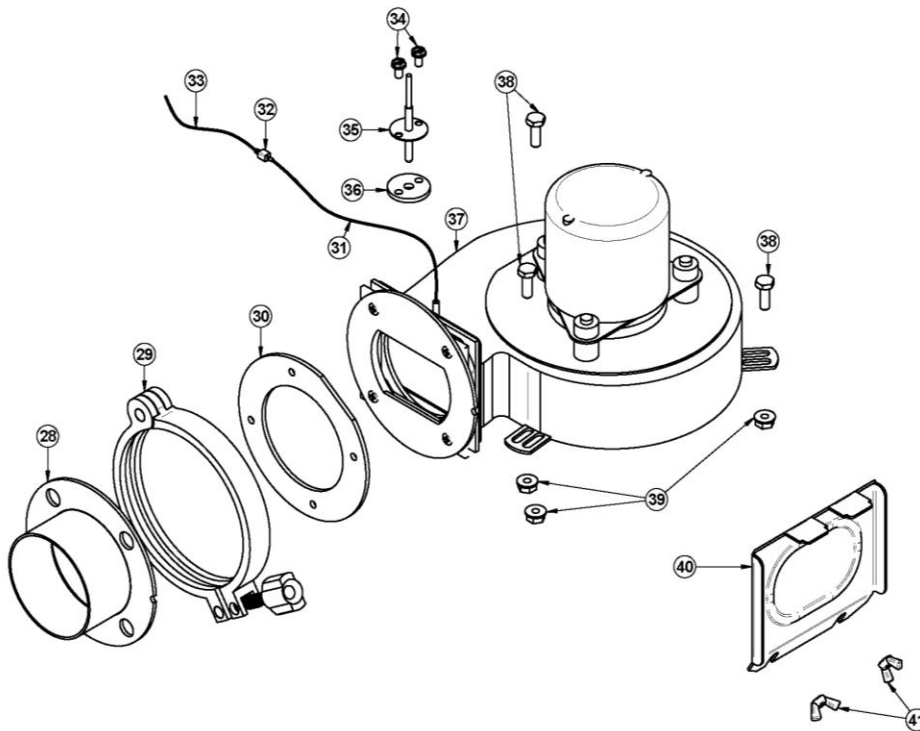

# SECTION E

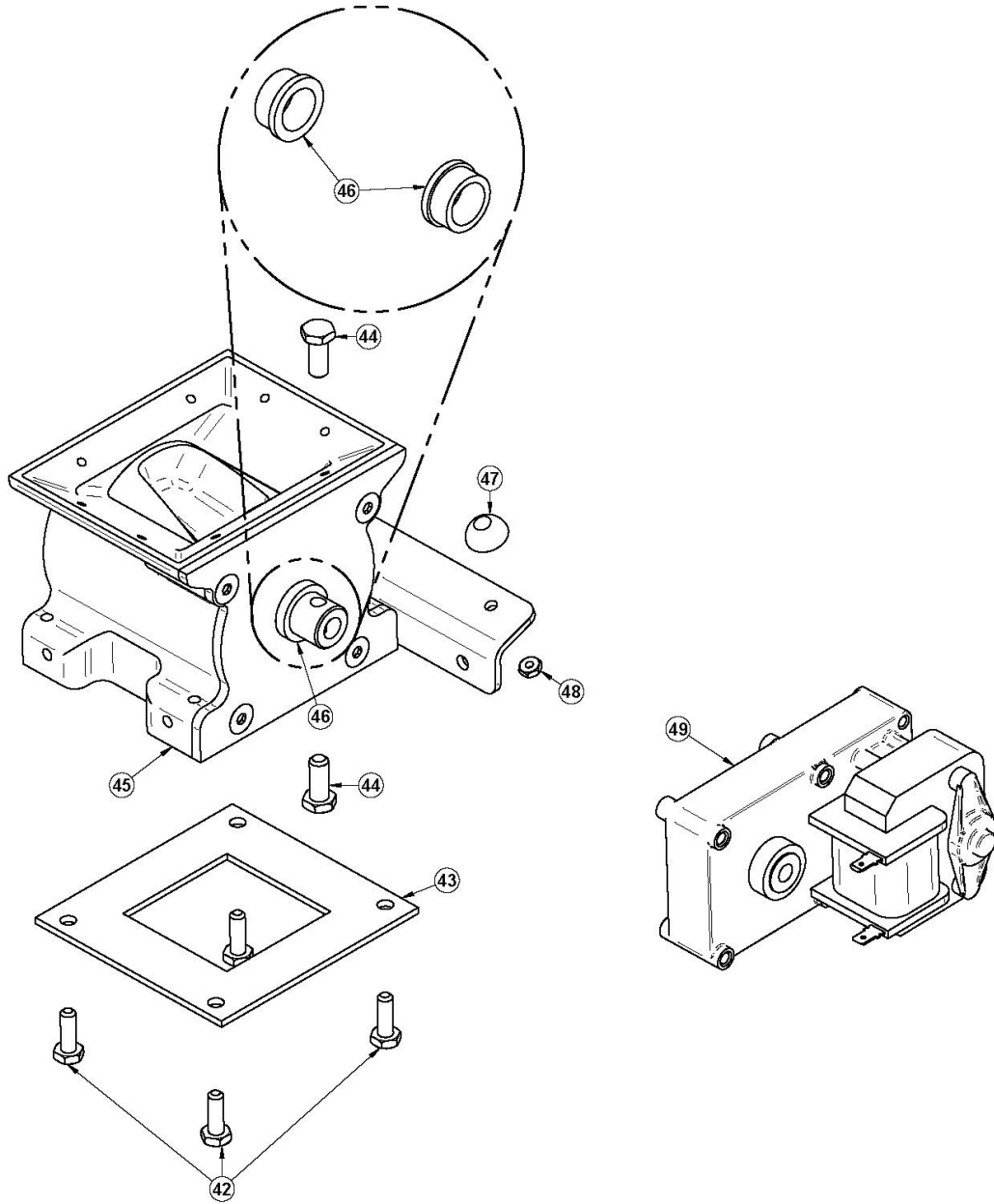

# SECTION F

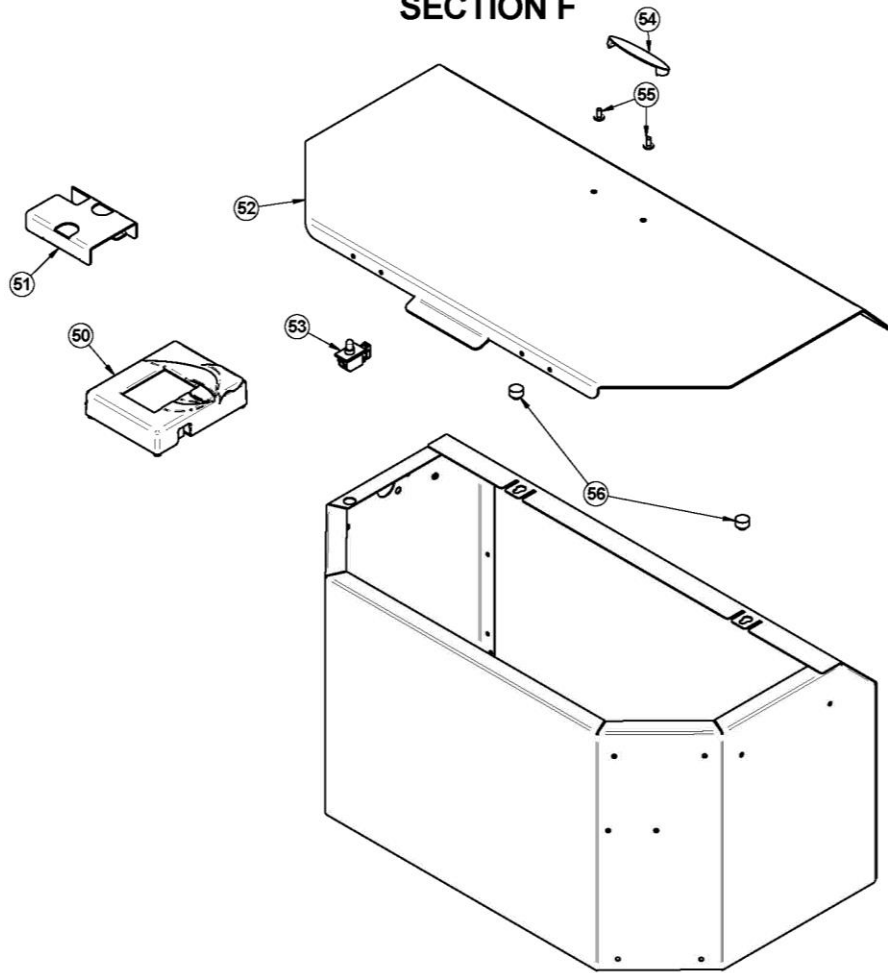

## SECTION G

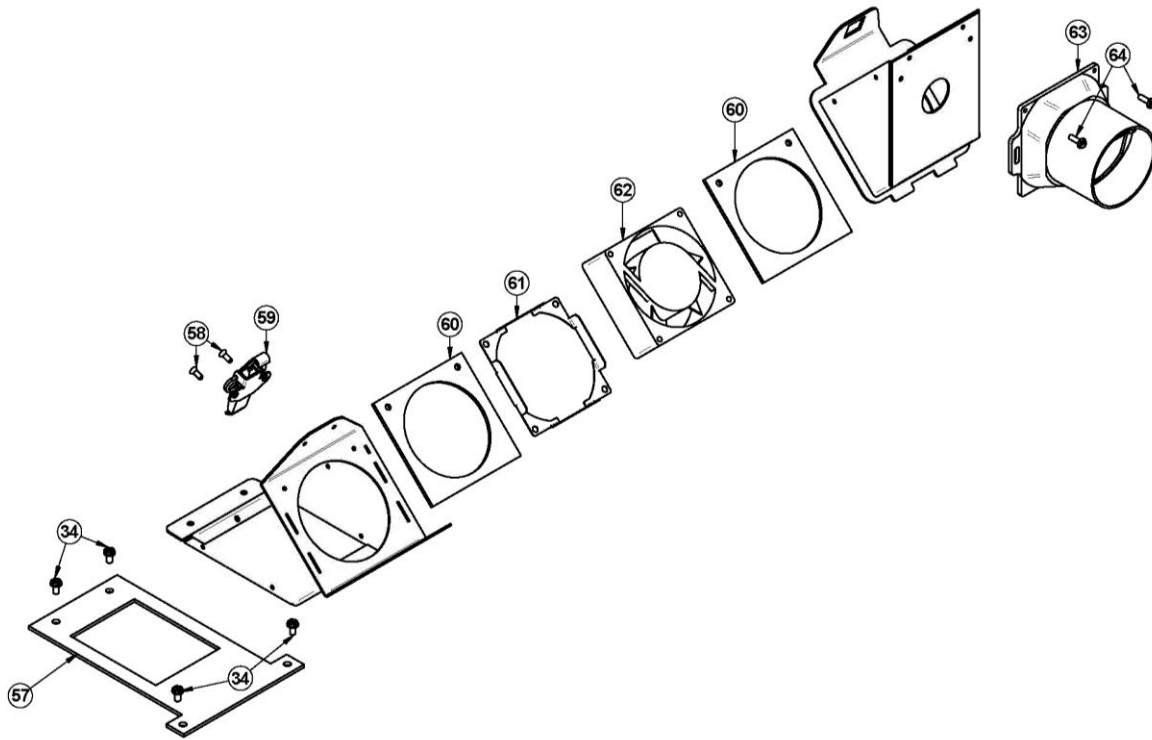

## SECTION H

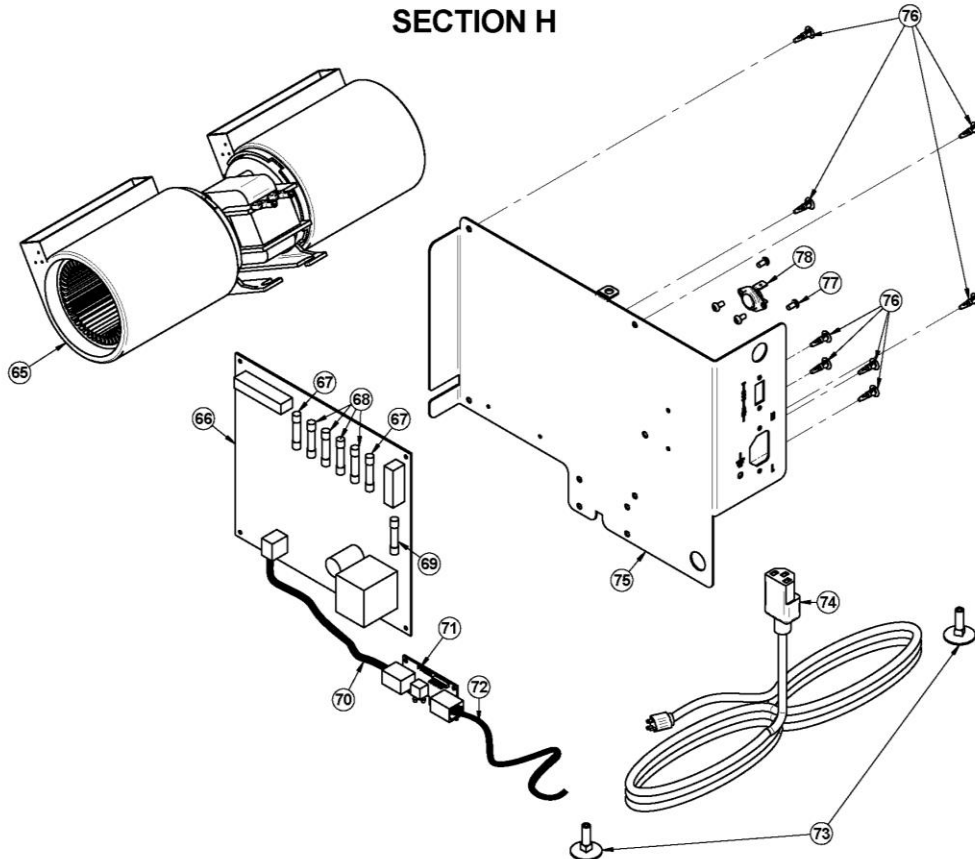

## SECTION I

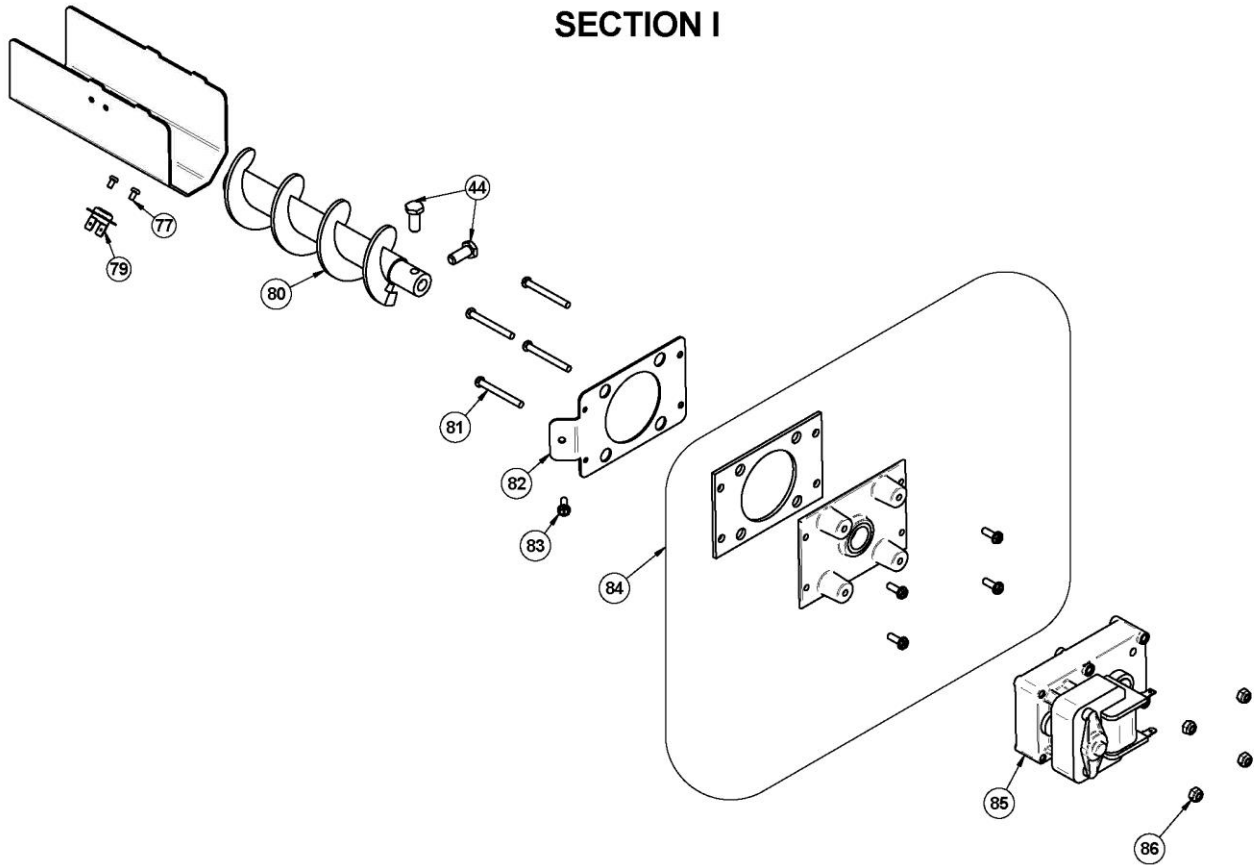

## SECTION J

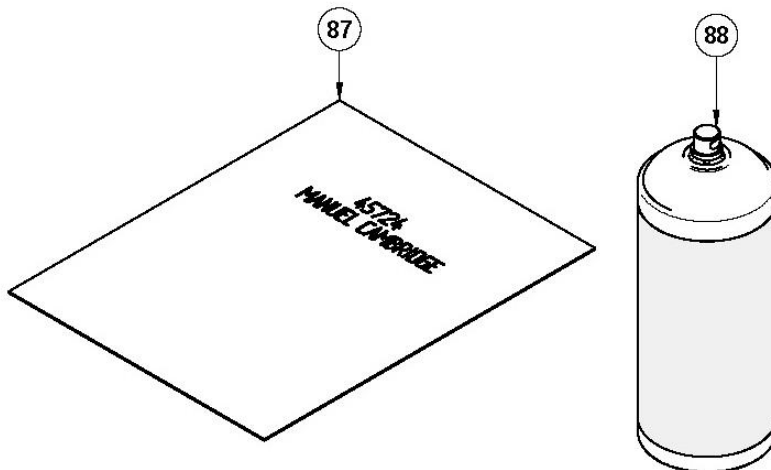

**IMPORTANT:** THIS IS DATED INFORMATION. When requesting service or replacement parts for your stove, please provide the model number and the serial number. We reserve the right to change parts due to technology upgrade or availability. Contact an authorized dealer to obtain any of these parts. Never use substitute materials. Use of non-approved parts can result in poor performance and safety hazards and will void your warranty.

#	Item	Description	Qty
1	PL69532	LEFT SIDE DECORATIVE PANEL	1
2	PL69545	REAR SIDE DECORATIVE PANEL	1
3	99999	BUILD TO ORDER	1
4	PL69563	RIGHT SIDE DECORATIVE PANEL	1
5	PL69544	RIGHT SIDE REAR PANEL	1
6	PL69545	LEFT SIDE REAR PANEL	1
7	SE24171	CAST IRON DOOR WITH GASKET AND HANDLE	1
8	AC06500	SILICONE AND 5/8" X 8' BLACK DOOR GASKET KIT	1
9	AC09153	HANDLE AND LATCH REPLACEMENT KIT	1
10	AC09185	DOOR LATCH KIT	1
11	30101	SPRING TENSION PIN 5/32" DIA X 1 1/2" L	1
12	SE69577	REPLACEMENT GLASS WITH GASKET 10 3/8" X 10 3/8"	1
13	AC06400	3/4" (FLAT) X 6' BLACK SELF-ADHESIVE GLASS GASKET	1
14	PL69583	GLASS RETAINER	2
15	SE53585	GLASS RETAINER KIT WITH SCREWS (12 PER KIT)	1
16	PL69565	BAFFLE	1
17	SE69575	REAR DECORATIVE CHANEL	1
18	PL69591	LOWER DECORATIVE HEAT SHIELD	1
19	SE68310	BURN POT	1
20	SE44132	IGNITER ASSEMBLY 120V 300W	1
21	60360	WHITE WIRE #18/7/1 C SEW-2 600V@200°C UL SF-2 CSA (22.5")	1
22	SE69558	ASH DRAWER ACCESS DOOR	1
23	28062	BLACK DRAWER HANDLE 3 25/32"	1
24	30106	MECHANICAL SCREW M4 X 12 LONG PAN PHILLIPS ZINC	2
25	AC06000	SILICONE AND 1/2" X 8' BLACK DOOR GASKET KIT	1
26	SE69551	ASH DRAWER	1
27	PL69574	FORNT CLEANOUT COVER	1
28	SE64345	EXHAUST PIPE ADAPTER	1
29	30762	VENT ADAPTER SECURE CLAMP	1
30	21392	EXHAUST ADAPTER GASKET	1
31	49006	3/8" X 24" SILICONE HOSE	1
32	60102	HOSE REDUCER 1/8" ID HOS TO 3/32" ID	1
33	30832	BLACK RUBBER HOSE EPDM WEATHER RESISTANT	2
34	30029	THREAD CUTTING SCREW 10-24 TYPE "F" X 3/8" HEX WASHER	6
35	44183	EXHAUST RTD PROBE	1
36	21418	RTD GASKET	1
37	SE44193	EXHAUST FAN WITH GASKETS	1
38	30093	BOLT 1/4-20 X 3/4" HEX GRADE 5	3

#	Item	Description	Qty
39	30220	FLANGED LOCKNUT 1/4-20	3
40	SE69576	SIDE CLEANOUT TRAP	1
41	30484	WING NUT 1/4-20	2
42	30093	BOLT 1/4-20 X 3/4" HEX GRADE 5	4
43	21436	ROTARY VALVE GASKET	1
44	30092	BOLT 5/16"-18 X 3/4" HEX GRADE 5	4
45	24033	ROTARY VALVE	1
46	30528	BRASS BUSHING FOR PELLET STOVE AUGER	2
47	30369	RUBBER BUMPER WITH THREADS (LARGE)	1
48	30417	BLACK HEX NUT #8-32	1
49	44038	AUGER GEAR MOTOR 1 RPM	1
50	SE69578	CAMBRIDGE TOUCH SCREEN BOARD (LCD) WITH HOUSING	1
51	PL69580	LCD SUPPORT	1
52	99999	BUILD TO ORDER	1
53	44098	HOPPER LID SAFETY SWITCH	1
54	30693	HOPPER LID HANDLE	1
55	30124	SCREW #8 - 32 X 5/16" TRUSS QUADREX ZINC	2
56	30757	RUBBER BUMPER	2
57	21468	AIR INLET BOX GASKET	1
58	30021	SELF TAPPING SCREW 8-32 "F" TYPE X 7/16" FLAT HEAD PHILLIPS BLACK	2
59	30439	SPRING CLAMP ZINC PLATED BRIGHT CHROMATE DIP	1
60	21400	COMBUSTION FAN GASKET	2
61	PL64359	COMBUSTION FAN GASKET FRAME	1
62	SE44147	AXIAL BLOWER ASSEMBLY 115V 9W 92 X 92 X 38	1
63	30777	PLASTIC BACKDRAFT DAMPER ASSEMBLY	1
64	30502	SELF TAPING SCREW #8 - 32 X 1/2" TYPE F x 3/4 HEX FLAT HEAD	2
65	44122	DOUBLE CAGE BLOWER 176 CFM (CLASS H)	1
66	PL68623	PROGRAMMED I/O PC CONTROL BOARD	1
67	44151	FUSE 5A / 250V (5 X 20) F1-CONV F5-EXHAUST F6-ACC	2
68	44150	FUSE 3A / 250V (5 X 20) F4-AUGER & DC IEC CONNECTOR	4
69	44013	FUSE 7.5A / 250V / 1/4" DIA. X 1 1/4" L	1
70	60363	8" COMMUNICATION WIRE - 4 CONDUCTOR	1
71	PL44170	PRESSURE SENSOR BOARD ASSEMBLY	1
72	60327	JUNCTION WIRE MAIN CONTROL BOARD TO LCD	1
73	30536	LEVELING BOLT 1/4 - 20 X 1"	2
74	60331	POWER CORD 6'	1
75	PL69542	CARD SUPPORT	1
76	30408	ELECTRONIC BOARD CLIP	8
77	30080	METAL SCREW #6 X 1/4 TYPE B PAN PHILLIPS	4
78	44058	THERMODISC 36T12 F160	1
79	44059	THERMODISC 36T11 L250-25 AUTOMATIC	1
80	24017	CAST IRON AUGER	1
81	30232	MECHANICAL SCREW 10-32 x 1-3/4" PAN QUADREX ZINC	4

#	Item	Description	Qty
82	PL69520	MOTOR SUPPORT PLATE	1
83	30026	THREAD CUTTING SCREW 10-24 F 5/8" HEX WASHER HEAD	1
84	SE24233	GEAR MOTOR SUPPORT WITH INSULATION	1
85	44106	GEAR MOTOR FOR PELLET STOVE AUGER 1.5 RPM	1
86	30233	NYLON HEX LOCK NUT 10-32 ZINC	4
87	45864	OWNER'S MANUAL CAMBRIDGE	1
88	AC05959	METALLIC BLACK STOVE PAINT - 342 g (12oz) AEROSOL	1

## APPENDIX A: HORIZONTAL AND VERTICAL VENT CHART

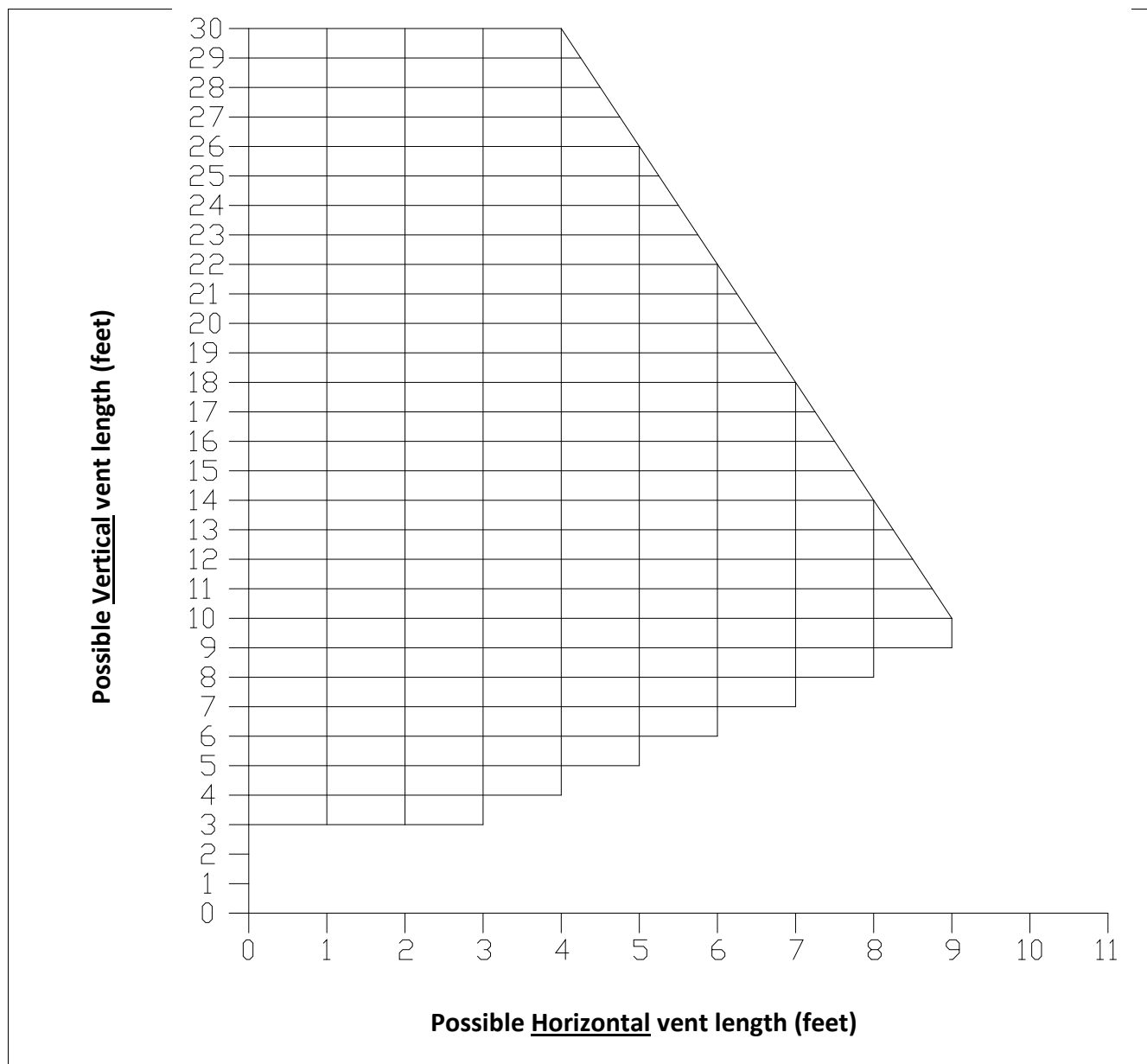

For example, let's imagine an installation consisting of a horizontal vent coming out at the back of the stove on a total distance of 8 feet. This horizontal run is followed by a tee and a 6-foot vertical rise. This type of installation is not acceptable. As you can see, the vent termination is clearly outside the allowed configuration zone on the chart because the venting system proposed **does not have at least one foot of vertical rise for each foot of horizontal run.**

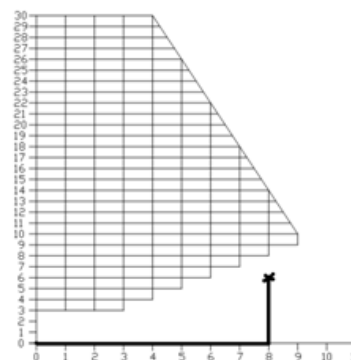

Instead, if the installation consisted of a horizontal vent coming out at the back of the stove on a total distance of 4 feet, followed by a tee and a 6-foot vertical rise, it would be acceptable. The termination is within the allowable configuration zone on the chart since it would have at least one foot of vertical rise for each foot of horizontal run. Furthermore, the total vertical rise is at least 3-feet high.

**WARNING:** To reduce the risk of smoke spillage there should always be at least one foot of vertical rise for each foot of horizontal run. In all cases, at least 3 feet of vertical rise is needed.

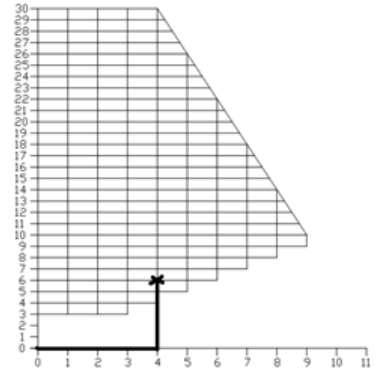

## APPENDIX B: CONNECTING AND INSTALLING THE TOUCHSCREEN

It is possible to install the wall mount support at the back of the stove or on an adjacent wall.

### To install it on the back of your stove:

Remove the screws already on the stove and use them to install the support on the stove.

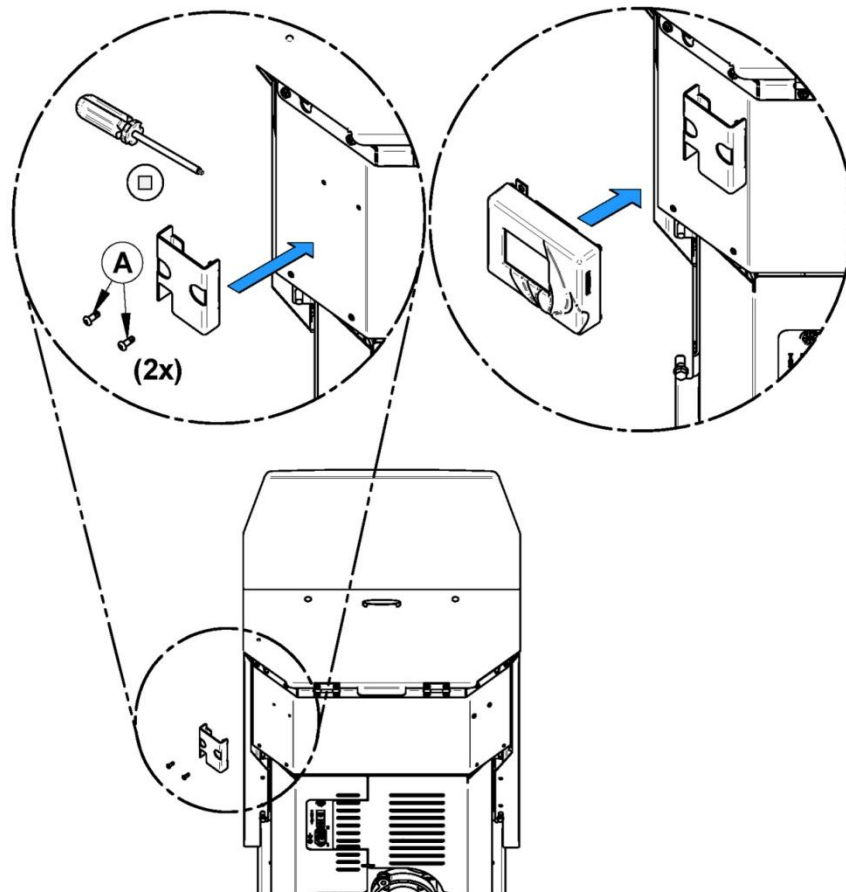

### To install on an adjacent wall:

#### **CAUTION**

**BEFORE INSTALLING THE TOUCHSCREEN SUPPORT ON THE WALL, CONNECT THE TOUCH SCREEN TO THE PRESSURE BOARD TO DETERMINE THE DISTANCE TO WHICH YOU CAN INSTALL THE TOUCH SCREEN.**

Secure the support to the wall with the appropriate hardware (not included). Use the 2 mounting holes provided for this purpose on the support.

### Connecting the touch screen

The wire that establishes the communication between your stove and the touch screen was plugged during manufacturing. You only have to plug the other end into the touch screen by cutting the ty-rap who holds it in place.

## APPENDIX C: INSTALLING A THERMOSTAT (AC05558)

Using a thermostat will help you maintain a constant temperature throughout the house. A low voltage thermostat (24 volts) is required. A fixed wall mount or hand held model can be used.

### NOTE

**THERMOSTAT MANUFACTURER'S INSTRUCTIONS ALWAYS OVERRIDE THE INFORMATION PUBLISHED IN THE FOLLOWING SECTION.**

### Thermostat location

Location of the thermostat is very important to obtain comfort and efficiency from your stove. Locate the thermostat 4 to 5 feet above the floor in accordance with applicable building codes. Install the thermostat in a location that provides good airflow characteristics and avoid areas behind doors, near corners, air vents, direct sunlight or heat generating devices. If the thermostat is installed in the same room as the stove, it should also be located at least 15 to 20 feet from the stove. To prevent cycling, you should avoid installing the thermostat on a poorly insulated outside wall or directly in front of the stove.

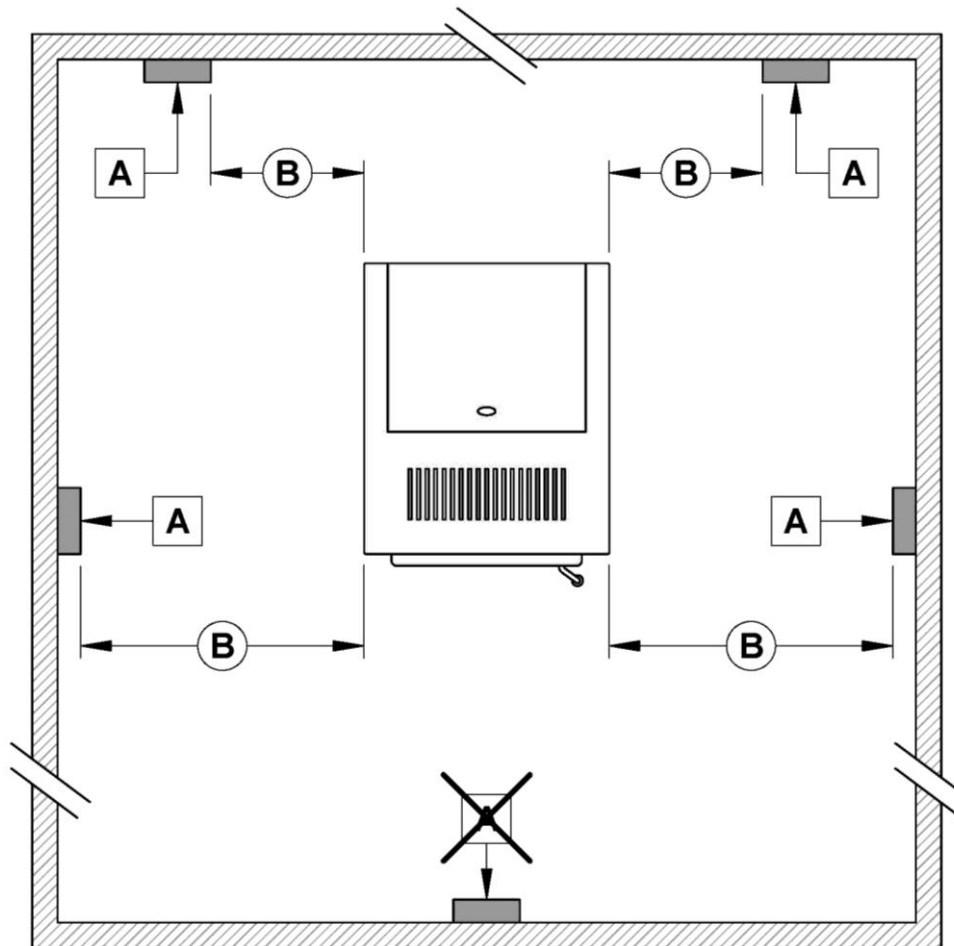

A	THERMOSTAT
B	15' MINIMUM

## Wired thermostat

Before installing the thermostat, unplug the power cord from the power outlet.

First, connect the two thermostat wires to the terminal block located at the rear on the right hand side of the stove when facing it. Loosen the two middle screws and insert the wires in the terminals. Tighten the two screws. Open the thermostat and connect the wires as per the manufacturer's instructions.

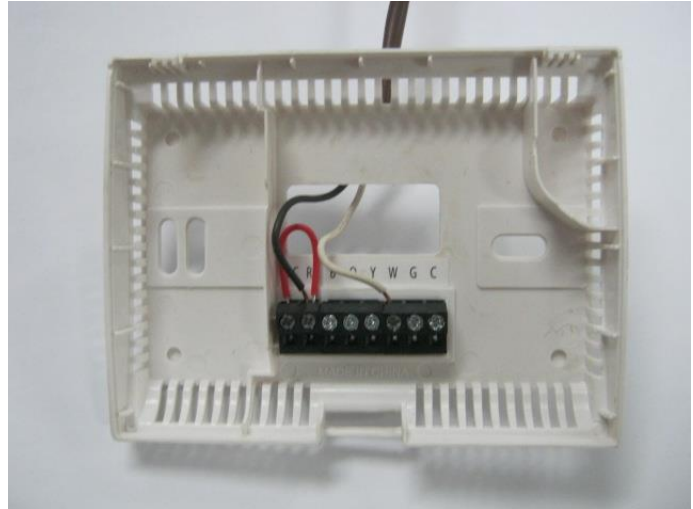
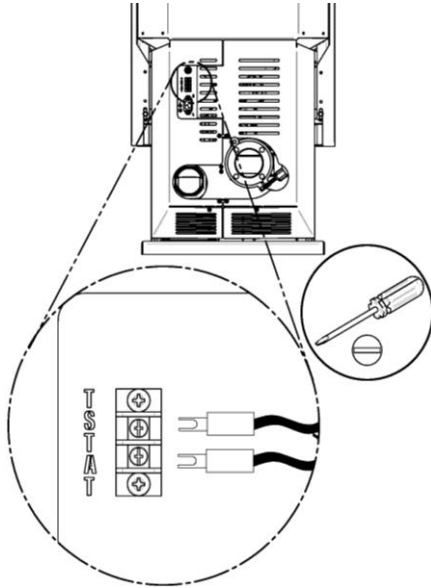

Connect one wire on "RH" and the other wire on "W". Red wire jumper can remain installed. For further information refer to the manufacturer's instructions.

## Wireless thermostat

If you are using a wireless thermostat or a hand held thermostatic remote control, connect the two thermostat wires to the terminal block located at the rear on the right hand side of the stove while facing it. If the receiver wires are equipped with quick-connect terminals you can connect them directly to the stove's wiring harness.

To do so, open the right hand side decorative panels and disconnect wires **(B)** and **(C)** attached to the rear of the terminal block **(A)** and connect them to the receiver.

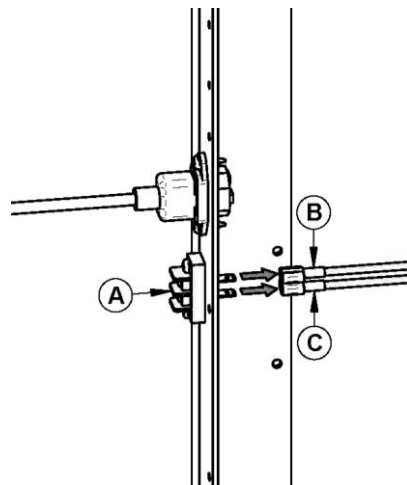

## APPENDIX D: MOBILE HOME INSTALLATION

### Anchoring the stove

#### WARNING

**FOR MOBILE HOME INSTALLATION, IT IS MANDATORY TO CONNECT THE STOVE TO AN OUTSIDE COMBUSTION AIR SOURCE (SEE APPENDIX E – COMBUSTION AIR SUPPLY).**

When installed in a mobile home, the stove must be anchored to the floor with two screws. Use the two anchoring holes (**A**) located for this purpose on each side of the pedestal, as shown on the following image.

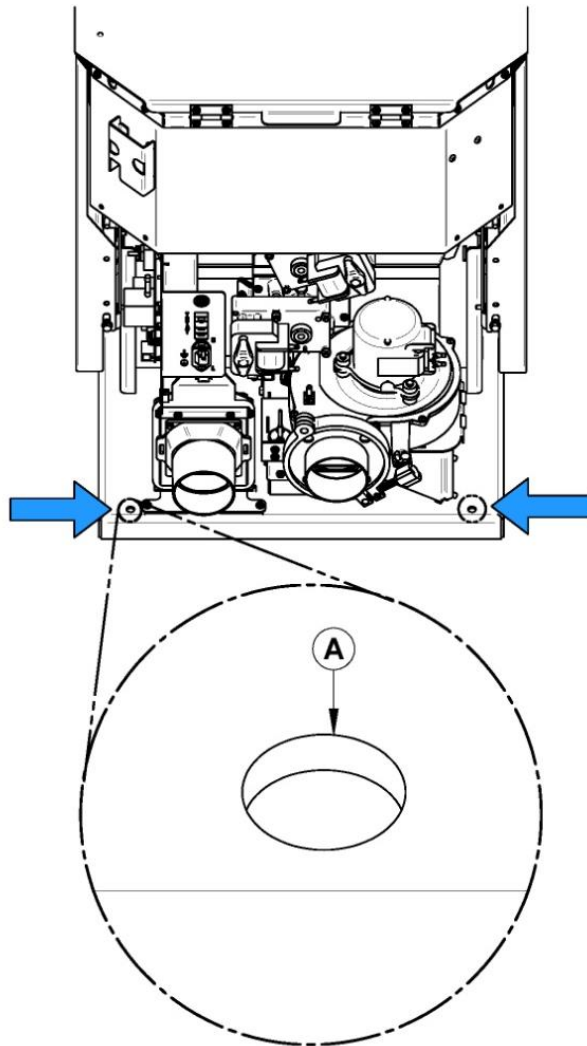

For use in a mobile home in Canada, this pellet stove must be connected to a vent system certified according to the standard or ULC/ORD-C441 CAN/ULC-S609. A vent system meeting the requirements of ULC S629M can also be used.

For use in a manufactured home in the United States, this pellet stove must be connected to a venting system that meets the requirements of UL 641 standard. A vent system that meets the requirements of UL 103 standard may also be used.

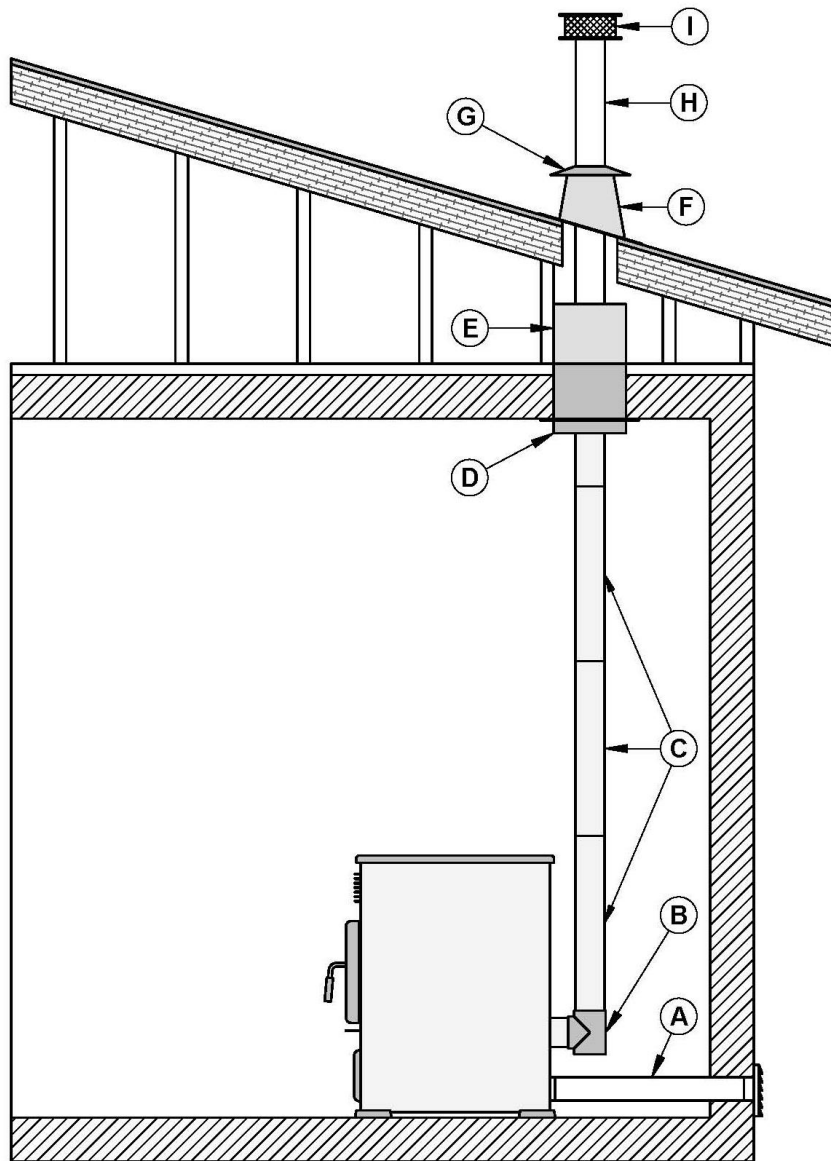

<b>A</b>	Fresh air intake
<b>B</b>	Tee
<b>C</b>	Pellet pipe length and/or slip section
<b>D</b>	Ceiling support
<b>E</b>	Attic insulation shield
<b>F</b>	Roof flashing
<b>G</b>	Storm collar
<b>H</b>	Pellet pipe length
<b>I</b>	Vertical rain cap

## APPENDIX E: COMBUSTION AIR SUPPLY

### WARNING

**FOR MOBILE HOME INSTALLATION, IT IS MANDATORY TO CONNECT THE STOVE TO AN OUTSIDE COMBUSTION AIR SOURCE. INSULATED PIPE SHOULD NEVER EXCEED 10 FEET.**

It is recommended to install an outside air inlet in or near the room where the stove is installed. When doing so, it is preferable to choose a wall which is not exposed to dominant winds, depending on the conditions surrounding your house.

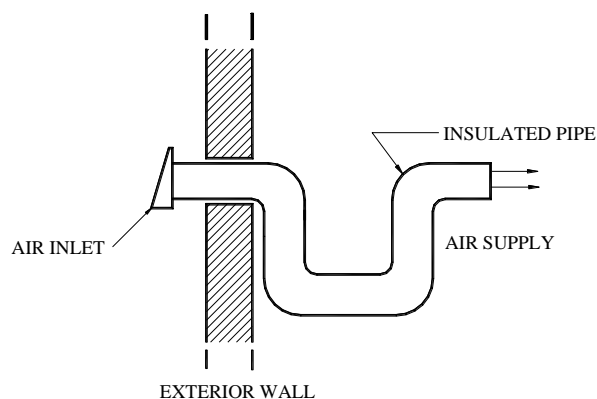

An insulated 3" inside diameter metallic pipe, either flexible or rigid, must be attached to the fresh air intake (D).

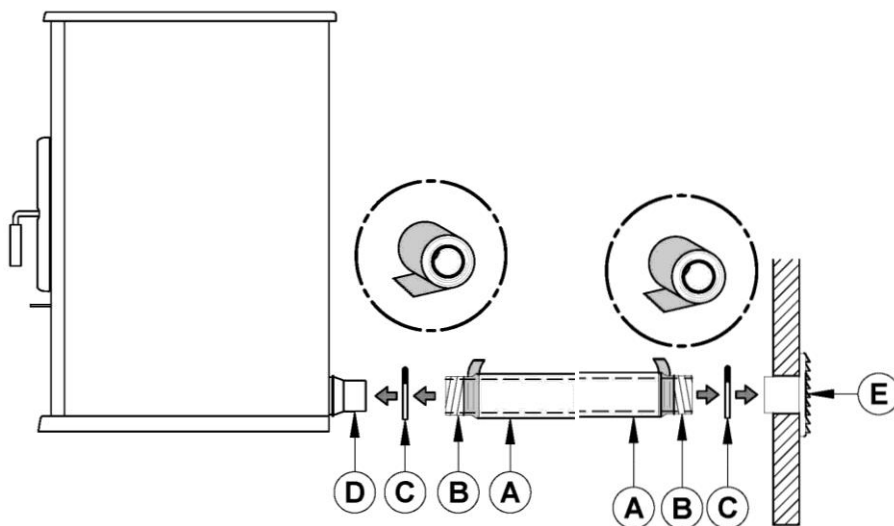

To complete the installation, make a hole of 1/4" to 1/2" (6 mm à 13 mm) bigger than the insulate pipe diameter in the outside wall of the house at the chosen location. From outside, place the outside air inlet cap (E) in the hole (open side down) and fasten the register to the wall, with screw. Place the insulated pipe (A) over the register tube and over the fireplace outside air connector (D). At each end, carefully pull back the insulation and plastic cover, exposing the flexible pipe. Attach the flexible pipe using pipe clamps(C). For a better seal, you may also use aluminum tape. Wrap the tape around the joint between the flexible pipe and the air inlets. Carefully push the insulation and plastic cover back over the pipe. Fix the plastic in place using aluminum tape.

A rodent guard (minimum 1/4" wire mesh) must be used at the termination (E). All connections must be secured and airtight by either using the appropriately sized hose clamp and/or UL-181-AP foil tape.

Make sure that the fresh air intake backdraft shutter (F) functions freely. The fresh air intake backdraft shutter is located in the back of the stove.

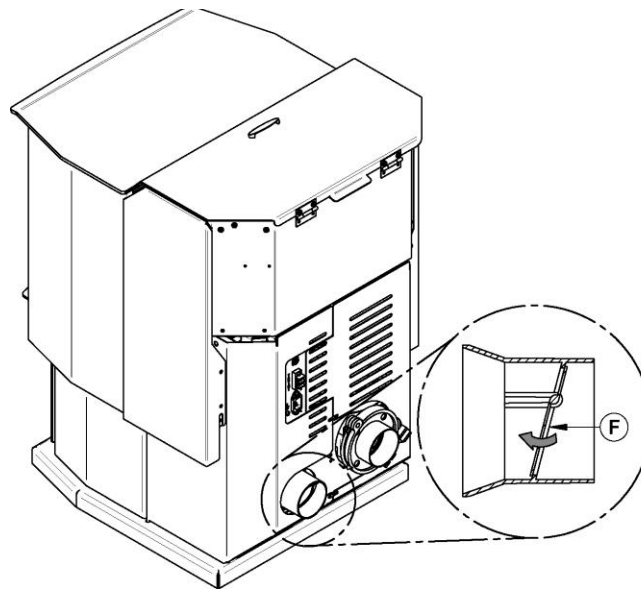

### Sources of Outside Combustion Air

#### **WARNING**

**IT IS FORBIDDEN TO DRAW COMBUSTION AIR FROM A BASEMENT, AN ATTIC, A GARAGE OR ANY CONFINED SPACE.**

- You can draw air from a ventilated crawl space underneath the floor.
- You can draw air directly from an outside wall, behind the stove.

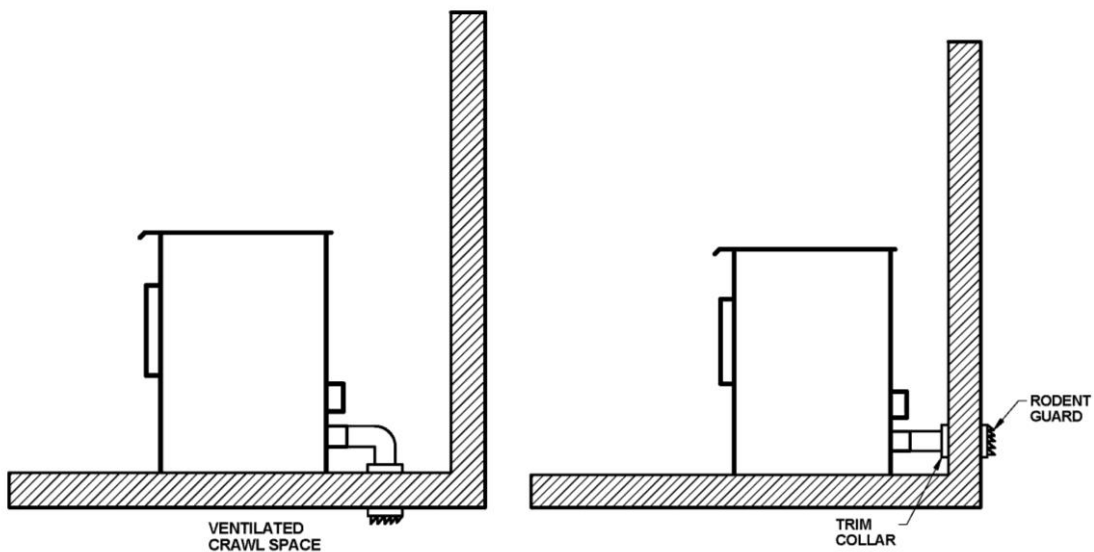

# ENERZONE LIMITED LIFETIME WARRANTY

The warranty of the manufacturer extends only to the original retail purchaser and is not transferable. This warranty covers brand new products only, which have not been altered, modified nor repaired since shipment from factory. Proof of purchase (dated bill of sale), model name and serial number must be supplied when making any warranty claim to your ENERZONE dealer.

**This warranty applies to normal residential use only. Damages caused by misuse, abuse, improper installation, lack of maintenance, over firing, negligence or accident during transportation, power failures, downdrafts, venting problems or under-estimated heating area are not covered by this warranty. The recommended heated area for a given appliance is defined by the manufacturer as its capacity to maintain a minimum acceptable temperature considering that the space configuration and the presence of heat distribution systems have a significant impact in making heat circulation optimum.**

This warranty does not cover any scratch, corrosion, distortion, or discoloration. Any defect or damage caused by the use of unauthorized or other than original parts voids this warranty. An authorized qualified technician must perform the installation in accordance with the instructions supplied with this product and all local and national building codes. Any service call related to an improper installation is not covered by this warranty.

The manufacturer may require that defective products be returned or that digital pictures be provided to support the claim. Returned products are to be shipped prepaid to the manufacturer for investigation. Transportation fees to ship the product back to the purchaser will be paid by the manufacturer. Repair work covered by the warranty, executed at the purchaser's domicile by an authorized qualified technician requires the prior approval of the manufacturer. All parts and labour costs covered by this warranty are limited according to the table below.

The manufacturer, at its discretion, may decide to repair or replace any part or unit after inspection and investigation of the defect. The manufacturer may, at its discretion, fully discharge all obligations with respect to this warranty by refunding the wholesale price of any warranted but defective parts. The manufacturer shall, in no event, be responsible for any uncommon, indirect, consequential damages of any nature, which are in excess of the original purchase price of the product. A one-time replacement limit applies to all parts benefiting from lifetime coverage. This warranty applies to products purchased after September 1<sup>st</sup>, 2015.

DESCRIPTION	WARRANTY APPLICATION*	
	PARTS	LABOUR
Combustion chamber (welds only**), heat exchanger (welds only**), and cast iron door frame.	Lifetime	5 years
Surrounds, heat shields, ash drawer, legs, pedestal, trims (aluminum extrusions), plating (defective manufacture**), and ceramic glass (thermal breakage only**).	Lifetime	N/A
Glass retainers, handle assembly, cleaning rod, air control mechanism, and auger.	5 years	1 year
Removable stainless steel components, burn pot, deflectors, supports, and baffle.	5 years	N/A
Blowers, auger motor, PC board, igniter, heat sensors, rheostat, wiring, and other controls.	2 years	1 year
Paint (peeling**), gaskets, insulation, masonry-like panels**, ceramic logs**, and other options.	1 year	N/A
All parts replaced under the warranty.	90 days	N/A

**\*Subject to limitations above. \*\*Picture required.**

Labour cost and repair work to the account of the manufacturer are based on a predetermined rate schedule and must not exceed the wholesale price of the replacement part.

Shall your unit or a components be defective, contact immediately your **ENERZONE** dealer. To accelerate processing of your warranty claim, make sure to have on hand the following information when calling:

- Your name, address and telephone number;
- Bill of sale and dealer's name;
- Installation configuration;
- Serial number and model name as indicated on the nameplate fixed to the back of your unit;
- Nature of the defect and any relevant information.

Before shipping your unit or defective component to our plant, you must obtain an Authorization Number from your ENERZONE dealer. Any merchandise shipped to our plant without authorization will be refused automatically and returned to sender.