

# 30" Digital Electric Smoker Owner's Manual

**MODEL:**  
PES23002

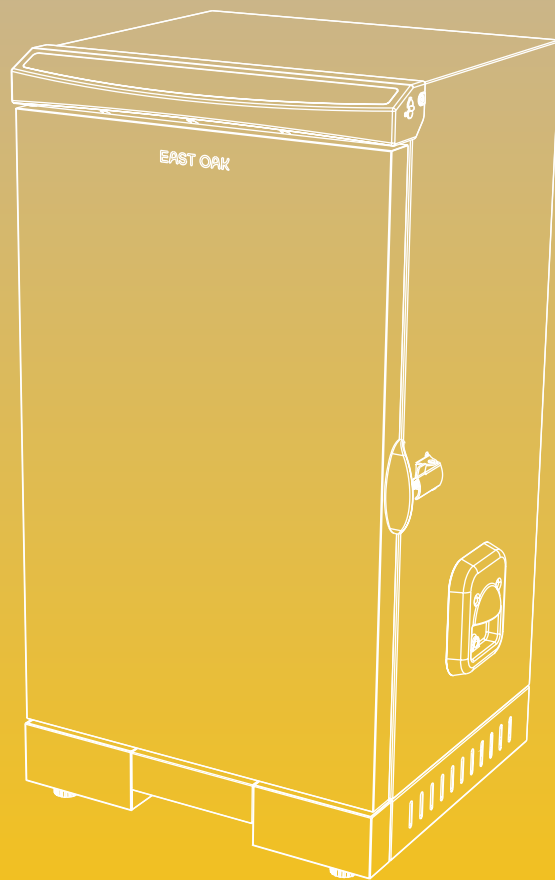

# EAST OAK

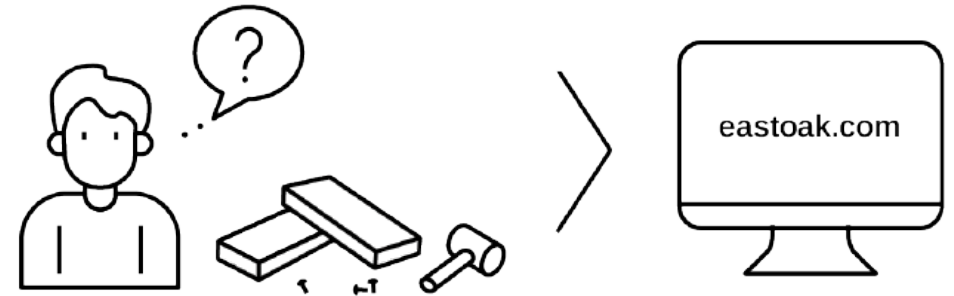

**Questions? Comments?  
Reach out to us for expert support!**

✉ [support@eastoak.com](mailto:support@eastoak.com)  
🌐 [eastoak.com](http://eastoak.com)  
☎ 1-833-EAST-OAK (USA)  
(1-833-327-8625) Mon-Fri 8am-8pm EST

Follow **eastoakliving** on



**Claim your 3-year warranty**  
at [eastoak.com/warranty](http://eastoak.com/warranty)

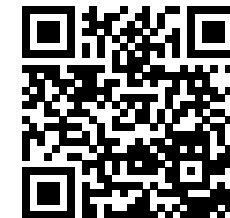

**Please scan the QR code  
to view the installation video**

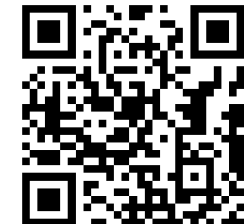

## IMPORTANT INFORMATION

Please check all parts and components to ensure no damage or missing items before starting the product's construction. If you have any problems or discover any missing parts, please contact customer service at [support@eastoak.com](mailto:support@eastoak.com).

- Some parts may contain sharp edges. Wear protective gloves if necessary during assembly.
- When using power tools, please adjust the gear to the minimum. Otherwise, it will cause damage to the parts.
- Assemble on a soft surface such as a drop sheet or rug to avoid scratching.

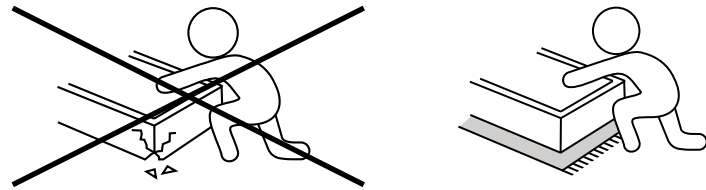

### **!** DANGER CARBON MONOXIDE HAZARD.

- Burning wood gives off carbonmonoxide which may cause death.
- **DO NOT** burn wood chips inside homes, tents, garages, or any enclosed areas.
- Use only outdoors where it is well-ventilated.

### **!** WARNING

- This manual contains important information necessary for the proper and safe use of this unit.
- Read and follow all warnings and instructions before using smoker and during use.
- Keep the manual for future reference. Some parts may have sharp edges. Handle with care.

### **!** CAUTION

- Do not use sharp or pointed tools to clean the smoker.
- Do not use abrasive oven cleaners, steel wool, or metal brushes to clean porcelain grates or smoker bodies. They will damage the finish.
- Only replace damaged parts with parts provided directly by the manufacturer. Do not attempt to repair damaged parts.

## **!** WARNINGS AND IMPORTANT SAFEGUARDS

### READ ALL INSTRUCTIONS BEFORE USE

#### General Safety Precautions

##### Setup

- Do not plug in the smoker until fully assembled and ready for use.
- Do not use the smoker during an electrical storm.
- It is recommended to keep children and pets away from smokers.
- The use of accessory attachments not recommended by the appliance manufacturer may cause injuries.
- Do not use this appliance other than for its intended use. This unit is for OUTDOOR HOUSEHOLD USE only and is NOT for commercial use.
- This unit is not to be used as a heater (see carbon monoxide danger warning on cover/page 2).
- The smoker box is designed for wood chips. Do not use wood chunks or pellets. NEVER use charcoal inside the smoker or smoker box, as it will cause a fire, create unsafe conditions, and damage the smoker.

##### Positioning

- Do not place the smoker on or near a hot gas or electric burner or in a heated oven.
- To prevent the smoker from being splashed or falling into the water, do not use the smoker within 10 feet of a pool, pond, or other body of water.
- Never use it inside enclosed areas, such as patios, garages, buildings, or tents.
- Do not operate under overhead construction, such as roof coverings, carports, awnings, or overhangs.
- Use the unit on a level, non-combustible stable surface such as dirt, concrete, brick, or rock.
- The unit MUST be on the ground. Do not place it on tables or counters. Avoid moving it across uneven surfaces.
- Keep the unit at least 36" (92cm) away from walls or railings.
- Do not use or store gasoline, kerosene, or other flammable liquids within 20' (6m) of the smoker when in use.
- Keep the smoker and electric controller dry and out of the rain at all times.

### **!** WARNING

- Failure to follow all manufacturer's instructions could result in serious personal injury and property damage.
- Read and follow all the information and safeguards in this product guide before attempting to assemble or operating this smoker.

## WARNING

The smoker should only be rolled on a smooth surface. Never roll the smoker up or down stairs or on uneven surfaces, as this could potentially damage the smoker and hurt the user.



## WARNINGS AND IMPORTANT SAFEGUARDS

### Use

- Surfaces may be hot, so avoid touching hot surfaces directly with any part of your body.
- Use long barbecue utensils for cooking, and use protective gloves when adding and removing food from the unit to avoid burns.
- Never leave the smoker unattended when it is on.
- Do not use glass, plastic, or ceramic cookware inside the smoker.
- Do not leave wood ashes in the smoker box. Empty it after each use and dispose of cold ashes by placing them in aluminum foil, soaking them with water, and discarding them in a non-combustible container.

### Cords

- Use only with a GFI (Ground Fault Interrupter) protected circuit, and use only on a properly grounded outlet.
- Do not operate any appliance with a damaged cord or plug or after the appliance malfunctions or has been damaged in any manner.
- To protect against electrical shock, do not immerse the cord, plugs, controller, or heating element in water or any other liquid. Keep the plug off the ground and dry.
- Do not let the cord hang over the edge of a table or counter, and do not let it touch hot surfaces.
- Never remove the grounding plug or use it with an adapter having only two prongs
- To disconnect, turn the control panel "OFF" and remove the plug from the outlet.
- If a longer detachable power-supply cord or extension cord is used: (1) the marked electrical rating of the cord set or extension cord should be at least as great as the electrical rating of the appliance, and (2) the cord should be arranged so that it will not drape over the counter or portable top where it can be pulled by children or tripped over unintentionally. The extension cord must be a grounding-type 3-wire cord.

### Other

- Do not use water or other liquid sprays to clean the product without first unplugging the electric controller and removing the heating element.
- Keep a fire extinguisher accessible during operation.
- Allow it to cool before putting on or taking off parts.
- This is a smoker, so there will be a lot of smoke produced when using wood chips. Smoke will escape through seams and turn the inside of the smoker black. This is normal. To minimize smoke loss around the door, the door latch can be adjusted to further tighten the door seal against the body. To adjust the door latch, loosen the hex nut or door latch, turn the hook clockwise to tighten it, and then secure the hex nut firmly against the door latch.

## DANGER Extension Cord Use

DO NOT USE 16 OR 18 GAUGE EXTENSION CORDS.

MISUSE COULD CAUSE DAMAGE TO HOUSEHOLD WIRING AND CAUSE A FIRE

For best smoker performance, using an extension cord is not recommended. If you must use an extension cord, the following is required for your safety:

- Use only an outdoor type with a 3-prong grounding plug, rated for 15 amperes or more, approved by UL, marked with a W-A, and a tag stating "Suitable for Use with Outdoor Appliance".
- Use the shortest length extension cord required. Do not connect two or more extension cords together.
- Keep connections dry and off the ground.
- Do not let the cord hang over the edge of a table top or other items where it can be pulled by children or tripped over.

### Ground Fault Interrupter:

- Since 1971 the National Electric Code (NEC) has required Ground Fault Interrupter devices on all outdoor circuits.
- If your residence was built before 1971, check with a qualified electrician to determine if a Ground Fault Interrupter protector exists.
- Do not use this appliance if the circuit does not have GFI protection.
- Do not plug this appliance into an indoor circuit.

## PARTS LIST

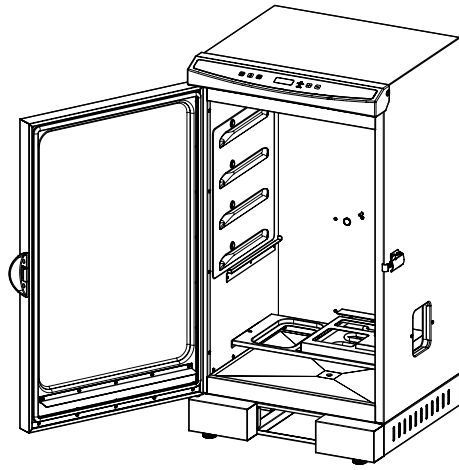

Smoker Assembly

**A** X 1 PC



Back Handle

**B** X 1 PC

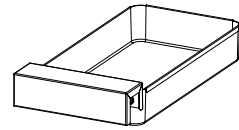

Grease Tray

**C** X 1 PC

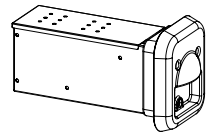

Smoker Box

**D** X 1 PC



Water Bowl

**E** X 1 PC

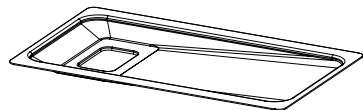

Drip Pan

**G** X 1 PC

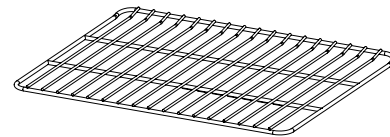

Cooking Rack

**F** X 4 PCS

## PARTS LIST

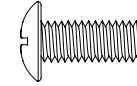

M6\*15 Screws

**L** X 2 PCS

## WHAT'S IN THE BOX

- 1 X Smoker Assembly
- 1 X Back Handle
- 1 X Grease Tray
- 1 X Smoker Box
- 1 X Water Bowl
- 1 X Drip Pan
- 4 X Cooking Racks
- 2 X Screws
- 1 X Owner's Manual

# ASSEMBLY INSTRUCTIONS

- 1** Stand the smoker upright, and install the handle(B) on the back of the smoker with two M6\*15 screws(L).

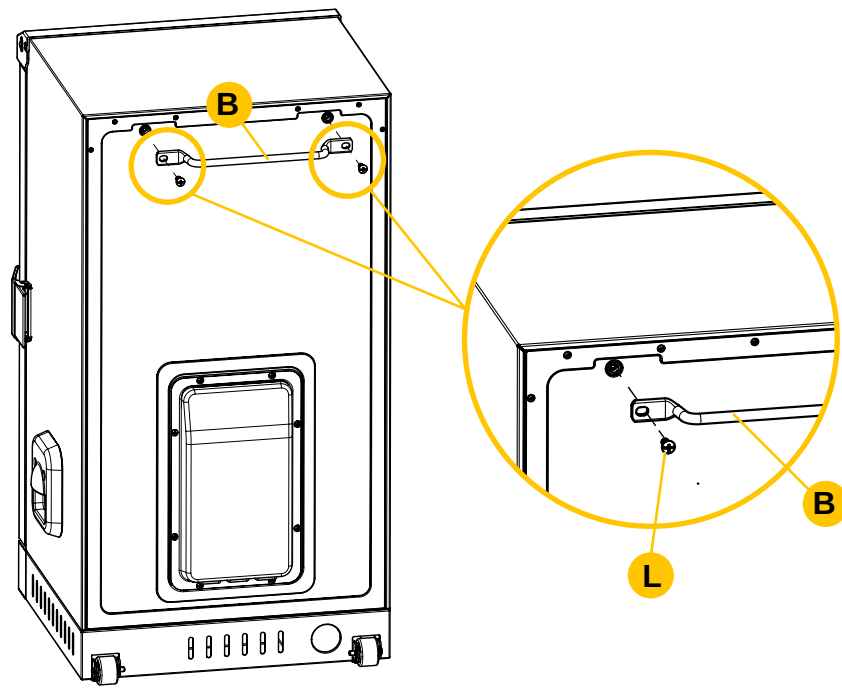

- 2** Push the grease tray into the installation position between the right and left decorative plates. The grease tray should snap into position when fully inserted.

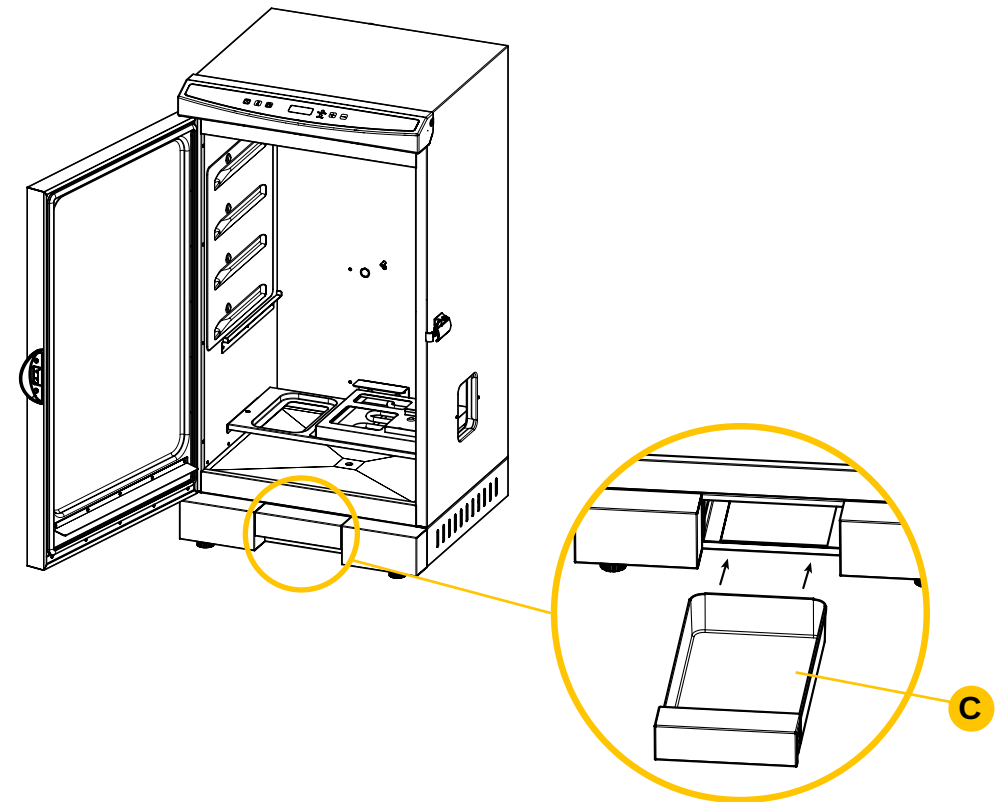

**3** Put the water bowl and smoker box into the corresponding position.

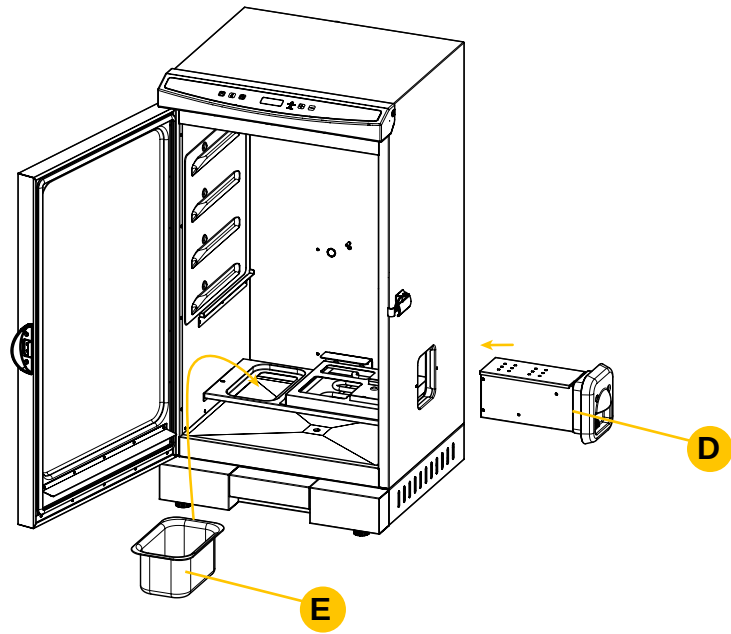

**5** Put cooking racks into the brackets on both sides of the smoker.

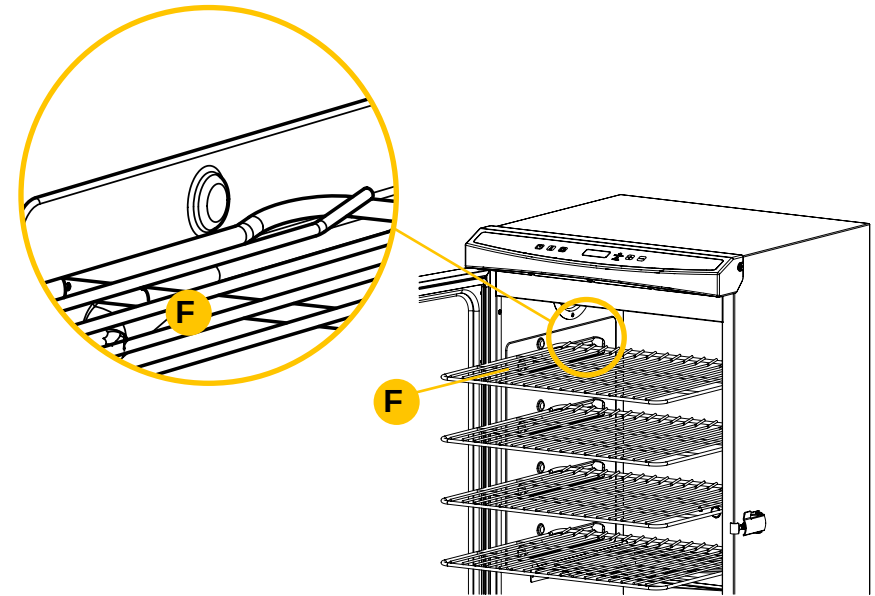

**4** Put drip pan into the brackets on both sides of the smoker chamber.

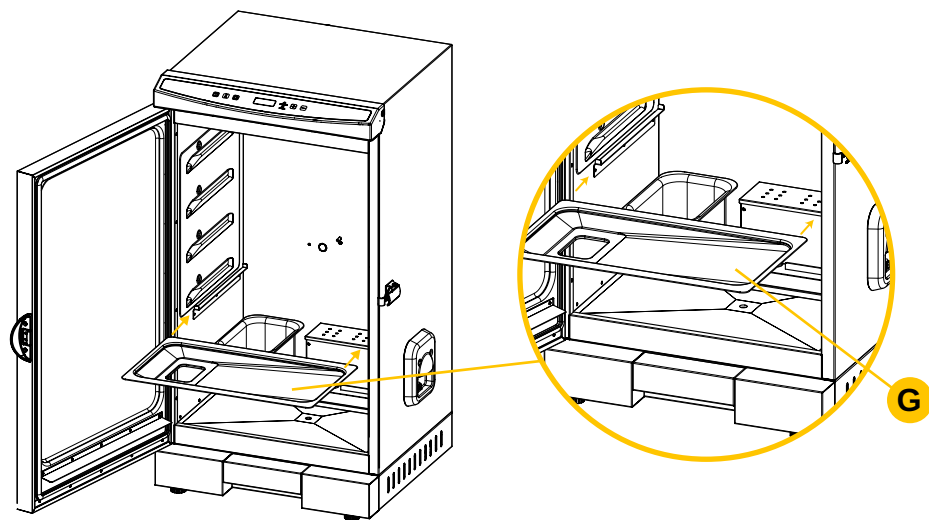

# PARTS DIAGRAM

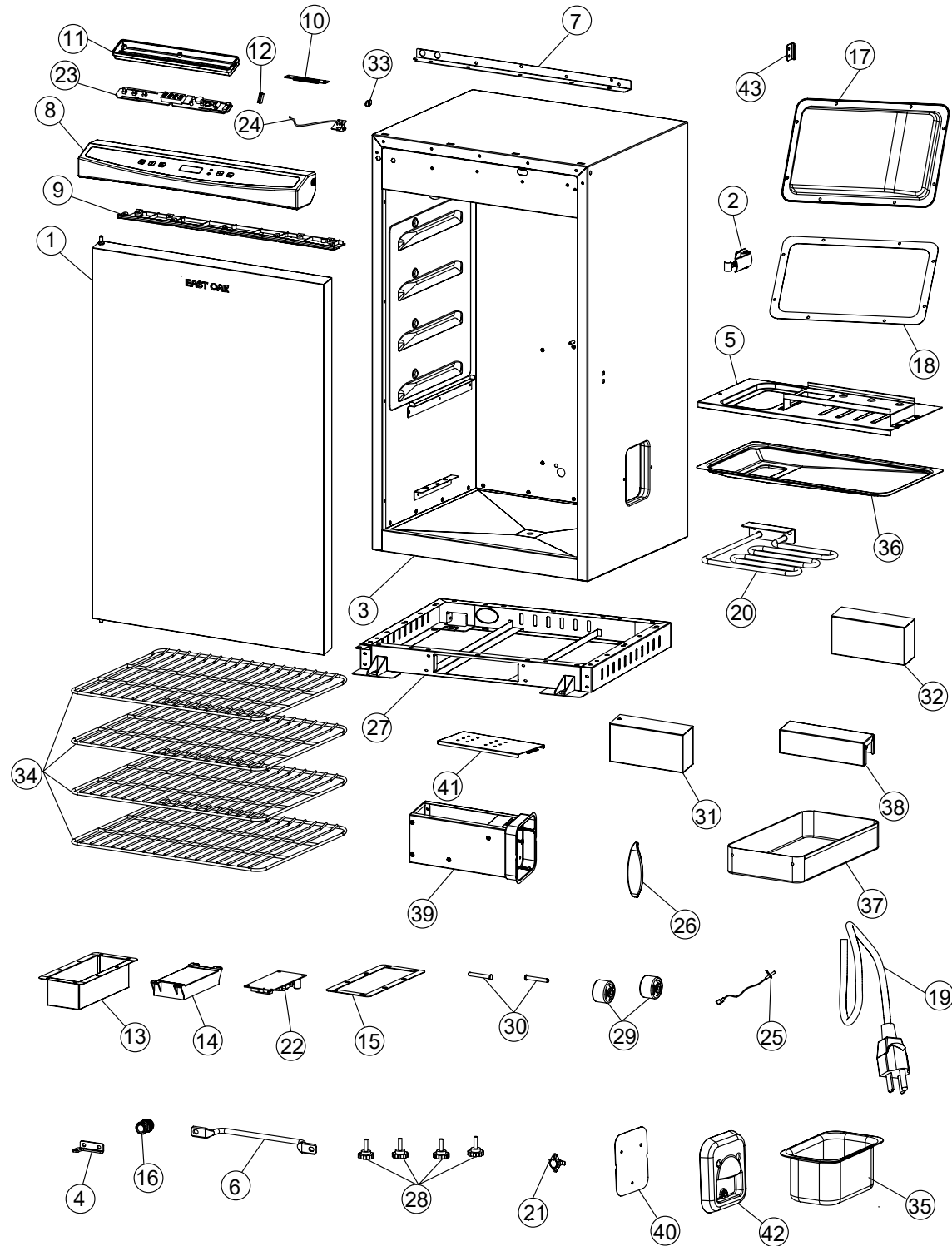

# PARTS LIST





ITEM NO.	QUANTITY	DESCRIPTION
1	1	DOOR ASSEMBLY
2	1	DOOR LATCH KIT
3	1	SMOKER BODY ASSEMBLY
4	1	DOOR TOP HINGE BRACKET KIT
5	1	HEATING ELEMENT REFLECTOR
6	1	BACK HANDLE
7	1	CONTROL PANEL FRAME BRACKET
8	1	CONTROL PANEL FASCIA KIT
9	1	CONTROL PANEL BOTTOM PLATE
10	1	LAMPSHADE
11	1	CONTROL PANEL HOUSING
12	1	CONTROL PANEL HOUSING OUTLET SEALING
13	1	GASKET
14	1	POWER BOARD GASKET
15	1	POWER BOARD HOUSING GASKET
16	1	POWER CORD METAL LOCK
17	1	REAR COVER OF HEATING ELEMENT
18	1	REAR COVER GASKET
19	1	POWER SUPPLY CORD KIT
20	1	HEATING ELEMENT
21	1	THERMOSTAT KIT
22	1	POWER BOARD KIT
23	1	CONTROL PANEL DISPLAY KIT
24	1	MEAT PROBE CONNECTION FEMALE PLUG KIT
25	1	CHAMBER TEMPERATURE PROBE KIT
26	1	DOOR HANDLE
27	1	BASE WELDING ASSEMBLY
28	4	LEG BOOT
29	2	WHEEL KIT
30	2	AXLE KIT
31	1	LEFT DECORATIVE PANEL
32	1	RIGHT DECORATIVE PANEL
33	1	WATERPROOF COVER FOR MEAT PROBE FEMALE JACKET
34	4	COOKING RACK
35	1	WATER BOWL

## PARTS LIST

ITEM NO.	QUANTITY	DESCRIPTION
36	1	DRIP PAN
37	1	GREASE TRAY
38	1	GREASE TRAY HANDLE
39	1	SMOKER BOX
40	1	RIGHT END HEAT INSULATION COVER
41	1	SMOKER BOX LID
42	1	SMOKER BOX HANDLE
43	1	DOOR LATCH BRACKET KIT

## CONTROL PANEL OPERATING INSTRUCTIONS



-  **Power Button** - Turns smoker on and off
-  **Temp Button** - Adjusts Cooking temperature
-  **Time Button** - Adjusts Cooking time
-  **Up Button** - Add to time/temp value
-  **Down Button** - Subtract from time/temp value

**Display:** The digital control panel is used to display the temperature setting value and actual measurement value in the chamber, the cooking timing time value, the countdown remaining time value, and the fault code.

**Keep Warm indicator light:** This indicator light is a green LED light, when the indicator light is on, it means that the control program has entered the “heat preservation and temperature control” state.

**Working indicator light:** The indicator light is a red luminous LED light. When the indicator light is on, it means that the control program has entered the “heating work” state.

## GENERAL OPERATION INSTRUCTIONS

Insert the power plug of the product into the socket of the corresponding voltage, turn on the power, and the controller on the product will be powered on immediately. When the power is turned on, the controller will make a long beep, indicating that the controller is powered on into standby. At this point, the following functional operations can be performed on the control panel.

### ON/OFF Operation

- Press the “power on/off” button once, the control panel will be turned on, and the display screen will display the initial state when it is powered on: the display screen will alternately display the time setting value 00:00 and the furnace temperature reading value. At this time, the 12-hour automatic shutdown timer clock starts counting down. If there is no operation at this time at 12 hours, it will automatically shut down, and the display screen will be turned off after 12 hours.
- In any state where the display is powered on, press the “power on/off” button again to enter the shutdown state.

### Temperature value unit conversion operation

The temperature value on the display shows the temperature value in Fahrenheit by default. If you need to convert the temperature value into Celsius, you need to press and hold the “+” and “-” buttons for more than 3 seconds at the same time in the initial state after power on. You can change the temperature reading from °F to °C, and in the same way, you can change °C back to °F. This operation must be set after turning on the machine and before other function settings are made. In other states, long press these two keys to set invalid.

### Cooking temperature setting operation

- When the display screen is powered on and displays the initial state, press the “Temperature Setting” button to enter the cooking temperature setting state, and the display screen flashes to display the temperature setting value (the default setting value of the system is 210°F (99°C));
- Adjust by pressing the “+” or “-” key to set the required cooking temperature value. When the displayed value is adjusted to the desired set value, press again. Click the “temperature setting” button to exit the cooking temperature setting state, and the next step is to set the timing time.

### Timing Setting

- Press the “Timing Setting” button to enter the “hour value” setting state of the timing time, and the display screen will flash and display the “hour value” setting value (the default initial setting value of the system is 00:00).
- By pressing the “+” or “-” button to adjust, set the required “hour value”. When the displayed value is adjusted to the desired setting value, press the “timing setting” button again. Enter the “minute value” setting state, the display screen will flash the “minute value” setting value and operate the “+” or “-” to set the required “minute value”. When the displayed value is adjusted to the desired setting value, then press the “Timer Setting” button to exit the timer setting state. At the same time, the heating element starts to be energized for heating, the heating indicator light on the control panel lights up, and the timer countdown begins.

### Working state and Keep Warming state

**When the program enters the heating working state, the display will alternately display the real-time temperature value inside the smoker and the remaining countdown time every 5 seconds.**

Once the timer countdown time ends:

- i) The controller will automatically reduce the set temperature in the smoker to °F (49°C) and enter the state of heat preservation and temperature control.
- ii) The display will show "120°F" (49°C) permanently.
- iii) The buzzer on the main control board will beep twice every 30 seconds until you press any key to end the beep or there is no press within 5 minutes.
- The key operation also ends the beep. To end the heat preservation and temperature control state, you can press the "power" button or the program will turn on after reaching the maximum 12 hours power off automatically.

### Buzzer

- When the power is turned on or every time a valid button is pressed, the buzzer will beep once.
- When the timer counts down to 00:00, the buzzer will beep twice every 30 seconds until the “power” switch is pressed key, or after reaching the maximum of 12 hours, it will automatically power off.
- When the furnace temperature sensor and the meat probe sensor fail, the buzzer will give a corresponding failure alarm sound. See the following simple troubleshooting content for details.

## Cleaning the Smoker (First-Time Use)

Prior to the smoker's first use, and after completion of the Assembly Instructions, the smoker must be seasoned to remove any residue: (such as oil and dust) which may have been left over from the manufacturing process. Please follow the instructions below:

1. Using a damp sponge and some mild detergent, wipe down the interior surfaces of your smoker, including all trays and racks. Be careful not to scratch any surfaces. Wash off the soapy residue with water. Open the smoker and let the unit air dry.
2. Using cooking oil spray or a small amount of cooking oil on a cloth, wipe down the inside of your smoker with a light coating of oil. Do not coat the smoker box, heating element, grease tray, or water tray with oil.
3. Make sure the water pan is in place with NO water, and the smoker box is in place with NO wood chips. Open up the vent all the way and keep it open throughout the cleaning process.
4. Plug in the appliance, and the display will immediately have power and make a beep sound.
5. Press the Power Button once. The control unit is now ready.
6. Press the Temp Button and set temperature to 275°F(135°C), which is the maximum setting.
7. Press the Time Button and set the time to two hours
8. Once two hours have elapsed, power off the smoker and allow the smoker to cool.
9. After the cleaning process and the smoker has cooled down, the smoker is ready for use.



**The smoker is HOT to touch during use. You need to wear protective gloves before use.**

## Preheating the Smoker



**Always preheat the smoker for 30-45 minutes (to max temp) before cooking. Wood chips and water should be added before preheating.**

1. Press the Temp Button.
2. Press and hold the UP button to raise the temperature to max temp, then release the button.
3. After the smoker has reached the max temperature it is ready for use.

## Cooking With the Smoker

1. After cleaning(if first-time use) and preheating the smoker as described above, the smoker is now ready for use. Remember, as part of the preheating setup, the wood chips and water should already be inserted into the Smoker Box and Water Pan.
2. Insert the meat into the preheated smoker carefully, using protective gloves and ensuring not to overfill the space. Keeping space between the meat and around the edges of the racks ensures proper air circulation.
3. Set the temperature at which to cook by using the Temp Button and then choose to either cook by Time function or by Meat Probe temperature. Refer to the operating instructions in the related sections on page 16 for each function.
4. When the internal temperature of the meat meets or exceeds the recommended USDA guidelines displayed earlier in this manual, power off the device. Remove meat from the smoker and enjoy! **Reminder: Never cook for time only. Always cook food to the USDA minimum required internal temperature.**
5. Meat and poultry cooked on a grill tend to brown quickly on the outside but may not be fully cooked on the inside. NEVER partially grill meat or poultry and finish cooking later. Color is never a reliable indicator of safety and doneness. Use a food thermometer to ensure the food has reached a safe minimum internal temperature. The food thermometer should be placed into the thickest part of the food and should not touch bone, fat, or gristle. Wash the food thermometer thoroughly with hot and soapy water before and after each use.
6. To correctly take the temperature of ground beef or poultry burgers, insert the food thermometer through the side of the patty until the probe reaches the center to detect cold spots. The thermometer should read 160 °F. Ground poultry burgers should read 165 °F.

## Food Safety

Safe handling, cooking, and storage steps are essential in preventing foodborne illness. You can't see, smell, or taste harmful bacteria that may cause illness. In every stage of food preparation, follow the four guidelines to keep food safe:

- **Clean**—Wash hands and surfaces often.
- **Separate**—Separate raw meat from other foods.
- **Cook**—Cook to the right temperature.
- **Chill**—Refrigerate food promptly.

### USDA Recommended Internal Cooking Temperatures

- Meat and poultry cooked on a grill tend to brown quickly on the outside but may not be fully cooked on the inside. NEVER partially grill meat or poultry and finish cooking later. Color is never a reliable indicator of safety and doneness. Use a food thermometer to ensure the food has reached a safe minimum internal temperature. The food thermometer should be placed into the thickest part of the food and should not be touching bone, fat, or gristle. Wash the food thermometer thoroughly with hot and soapy water before and after each use.
- To correctly take the temperature of ground beef or poultry burgers, insert the food thermometer through the side of the patty, until the probe reaches the center to detect cold spots. The thermometer should read 160 °F. Ground poultry burgers should read 165 °F.
- Cook all food to these minimum internal temperatures as measured with a food thermometer before removing food from the heat source. For reasons of personal preference, consumers may choose to cook food to higher temperatures.

PRODUCT	MINIMUM INTERNAL TEMPERATURE & REST TIME
Beef, Pork, Veal & Lamb Steaks, Chops, Roasts	145° F(62.8° C) and allow to rest for at least 3 minutes
Ground Meats	160°F(71.1°C)
Ground Poultry	165°F(73.9°C)
Ham, fresh or smoked (uncooked)	145° F(62.8° C) and allow to rest for at least 3 minutes
Fully Cooked Ham (to reheat)	Reheat cooked hams packaged in USDA-inspected plants to 140°F(60°C) and all others to 165°F(73.9°C)
All Poultry (breasts, whole bird, legs, thighs, wings, ground poultry, giblets, and stuffing)	165°F(73.9°C)
Eggs	160°F(71.1°C)
Fish & Shellfish	145°F(62.8°C)
Leftovers	165°F(73.9°C)
Casseroles	165°F(73.9°C)

Visit <https://www.fsis.usda.gov> for more information on Food Safety.

## Care Instructions

- Clean rack supports, racks, water bowl, and drip pan with mild dish detergent. Rinse and dry thoroughly.
  - Clean the interior frame, door glass, meat probe, and exterior of the smoker with a damp cloth only. Do not use any cleaning agents. Dry thoroughly.
  - It is important to clean the door seal and the corresponding inside seam with a damp cloth after each use to preserve the life of the seal.
  - Always take care not to scratch any surfaces inside or outside the unit to reduce the chance of rust or corrosion.
  - Do not clean any of the smoker surfaces while hot.
  - The Smoker Box should be cleaned frequently to remove ash, residue, and dust.
- Helpful Tips .

### Helpful Tips

- Do not cover racks with aluminum foil, as doing so would not allow heat to circulate properly.
- Dry or pre-soaked chips are both okay to use in the smoker. Dry chips are recommended as they will burn faster and produce more intense smoke. Chips pre-soaked in water (for approximately 30 minutes) will burn slower and have less intense smoke.

- When outside temperature is cooler than 65°F (18°C) and/or altitude is above 3,500 feet (1,067m), additional cooking time may be required, To ensure that meat is completely cooked use a meat thermometer to test internal temperature.
- Do not overload the smoker with food. Load enough to ensure there is space between the food and also on the edges of the rack to assist in circulation of the heat.
- Do not overpack the Smoker Box with wood chips, do not fill the Water Pan past the max fill line.
- Always cook with the Water Pan and Smoker Box in place whether or not they are filled.
- Do NOT open the smoker door during operation unless absolutely necessary. Opening the door will allow heat to escape and slow the cooking time.

### Meat Smoking Flavor Profiles & Pairings

WOOD	STRENGTH	RECOMMENDED PAIRING
Hickory	Intense	Beef, Pork
Mesquite	Intense	Beef, Pork
Oak	Medium	Pork, Beef, Poultry
Maple	Mild	Poultry, Vegetables, Cheese
Apple	Mild	Pork, Poultry, Fish
Cherry	Mild	Pork, Poultry, Beef, Lamb, Duck

**Note:** Sometimes condensation may form on the glass door. This is normal. The effect can be caused by smoker placement, outdoor temperature, excess water in the pan, venting, and lower cook temperatures among other reasons. If you see liquid seeping from the bottom of the unit it is condensation not oil/grease. Remember only use this appliance outdoors in a secure area away from children and animals.

**Note:** Dry or pre-soaked chips may be used with this unit.

TROUBLESHOOTING		
Issue	Possible Cause	RECOMMENDED PAIRING
Smoker not heating	Smoker is not plugged in fully.	Remove plug from outlet and plug in again.
	No power.	Turn the Smoker OFF and unplug from outlet. Check or replace in this order: <ul style="list-style-type: none"> <li>• Check for tripped household circuit breakers or GFCI (Ground Fault Circuit Interrupter). Reset or replace if necessary using a GFCI rated for 15 amperes or more.</li> <li>• Try a known, working appliance in the outlet to ensure it is not an issue with the outlet.</li> <li>• Try a different outlet, preferably on a different circuit.</li> <li>• Unplug thermostat connections and reconnect. Replace Thermostat Kit if necessary.</li> <li>• Unplug control panel connections and reconnect. Replace Control Panel Display Kit.</li> </ul> If necessary <ul style="list-style-type: none"> <li>• Unplug power board connections and reconnect. Replace Power Board Kit if necessary.</li> </ul>
	Faulty heating element.	Turn the Smoker OFF and unplug from outlet. Check or replace in this order: <ul style="list-style-type: none"> <li>• Unplug heating element connections and reconnect.</li> <li>• Replace heating element.</li> <li>• Replace Thermostat kit.</li> <li>• Replace Control Panel Display Kit.</li> <li>• Replace Power Board Kit.</li> </ul>
Circuit breaker trips or fuse blows	Another appliance plugged into same circuit as the smoker.	Remove other electrical appliances on the same circuit, then try again.
	Faulty heating element.	Remove other electrical appliances on the same circuit, then try again.
	Poor electrical connections.	Turn the Smoker OFF and unplug from outlet. Check or replace in this order: <ul style="list-style-type: none"> <li>• Unplug thermostat connections and reconnect. Replace Thermostat Kit if necessary.</li> <li>• Replace Power Supply Cord Kit.</li> </ul>
No display	Faulty control panel.	Turn the Smoker OFF and unplug from outlet. Check or replace in this order: <ul style="list-style-type: none"> <li>• Unplug smoker and plug back into outlet (beep will sound when plugged in).</li> <li>• Unplug thermostat connections and reconnect. Replace Thermostat Kit if necessary.</li> <li>• Unplug control panel connections and reconnect, Replace Control Panel Display Kit if necessary.</li> <li>• Unplug power board connections and reconnect. Replace Power Board Kit if necessary.</li> </ul>
Smoker will not cook properly	Door of smoker is left open.	Close door on smoker while cooking. Heat will escape quickly when the door is opened, increasing the required cooking time.
	Insufficient preheat.	Always use controller PH (preheat) setting before starting a cook.
	Inappropriate extension cord.	Use only outdoor type with 3 prong grounding plug, rated for 15 amperes or more, approved by UL, marked with a W-A and a tag stating "Suitable for Use with Outdoor Appliance". Use the shortest length extension cord required. Do not connect 2 or more extension cords together. A 12 or 14 gauge extension cord of 50ft. or less is acceptable.
Flare-ups	Excess fat in meat.	Trim fat from meat before cooking.
	Excessive cooking temperature.	Adjust (lower) temperature as needed.
	Grease build up.	Clean smoker, cooking grates, drip pan, grease tray and water pan.
Persistent grease fire	Grease trapped by food build up.	Turn the Smoker OFF and unplug from outlet, Keep door open and let fire burn out.
		<b>Do not apply water to fire.</b> Personal injury may result.
		After smoker cools, clean smoker, cooking grates, drip pan, grease tray and water pan.

ERROR CODES		
Error codes	Issue	Recommendation
Err1	Alarm sounding with 3 beeps every 30 seconds and will only stop when the Power Button is turned to off. Blinking "Err1" appears when you press the Power Button when starting your smoker. Blinking "Err1" appears when you press the Temp Button on your smoker. Blinking "Err1" appears when you press any buttons on your smoker. Refer to online Electrical Replacement Manual for instructions on removal and replacement.	Turn Smoker OFF and unplug from outlet, Replace Thermostat Kit.
Err2	Alarm sounding with 3 beeps every 30 seconds and will only stop when the Power Button is pressed Blinking "Err2" appears when you press the Power Button when starting your smoker. Blinking "Err2" appears when you preheat your smoker.	Turn Smoker OFF and unplug from outlet Check or replace in this order 1. Replace Thermostat Kit. 2. Replace Control Panel Display Kit. 3. Replace Power Board Kit.
Err3	Blinking "Err3" appears when you press the Meat Probe Button after starting your smoker. Blinking "Err3" appears when you press the Meat Probe Button when you want to check the food temperature.	Turn Smoker OFF and unplug from outlet Check or replace in this order 1. Replace Meat Probe. 2. Replace Meat Probe Housing. 3. Replace Control Panel Display Kit.
Err4	after starting your smoker. Blinking "Err4" appears when you press the Meat Probe Button when you want to check the food temperature. Blinking "Err4" appears when you press the Meat	Turn Smoker OFF and unplug from outlet Check or replace in this order 1. Replace Meat Probe. 2. Replace Meat Probe Housing.
Remote control is unresponsive	The remote control is not sync'd to the Smoker.	Reset the Remote Control: 1. Main Control: press Meat probe button and hold for 3 seconds until it beeps. 2. Remote Control: press Meat probe button twice on the remote.
Er°F or Er°C	Blinking Er °F (or Er °C) appears in the <b>Set Chamber Temperature</b> bar of your remote control.	Turn Smoker OFF and unplug from outlet Check or replace in this order 1. Replace Thermostat Kit. 2. Replace Control Panel Display Kit. 3. Replace Power Board Kit.
Er°F or Er°C	Blinking Er °F (or Er °C) appears in the <b>Meat Probe Temp</b> bar of your remote control.	Turn Smoker OFF and unplug from outlet Check or replace in this order 1. Replace Meat Probe. 2. Replace Meat Probe Housing.

## WARNING:

- Changes or modifications to this unit not expressly approved by the party responsible for compliance could void the user's authority to operate this equipment.
- This equipment has been tested and found to comply with the limits for a Class B digital device, pursuant to Part 15 of the FCC Rules. These limits are designed to provide reasonable protection against harmful interference in a residential installation.
- This equipment generates, uses and can radiate radio frequency energy and, if not installed and used in accordance with the manufacturer's instructions, may cause interference harmful to radio communications.
- There is no guarantee, however, that interference will not occur in a particular installation. If this equipment does cause harmful interference to radio or television reception, which can be determined by turning the equipment off and on, the user is encouraged to try to correct the interference by one or more of the following measures:
  - Reorient or relocate the receiving antenna.
  - Increase the separation between the equipment and receiver.
  - Connect the equipment to an outlet on a circuit different from that to which the receiver is connected.
  - Consult the dealer or an experienced radio or TV technician for help.

This device complies with Part 15 of the FCC and RSS Rules.

Operation is subject to the following two conditions:

1. This device may not cause harmful interference.
2. This device must accept any interference received, including interference that may cause undesired operation.

## LIMITED WARRANTY

- Manufacturer warrants to the **original consumer-purchaser** only that this product shall be free from defects in workmanship and materials after correct assembly and under normal and reasonable home use for the periods indicated below beginning on the date of purchase. The manufacturer reserves the right to require that defective parts be returned, postage and or freight pre-paid by the consumer for review and examination.
- **The original recipient will be responsible for all shipping charges for parts replaced under the terms of this limited warranty.**
- This limited warranty is applicable in the United States and Canada only, is only available to the original owner of the product and is not transferable.
- **Manufacturer requires proof of your date of purchase.**
- This limited warranty applies to the functionality of the product ONLY and does not cover cosmetic issues such as scratches, dents, corrosion or discoloring by heat, abrasive and chemical cleaners or any tools used in the assembly or installation of the appliance, surface rust, or the discoloration of stainless steel surfaces. Paint is not warranted and will require touch up. **RUST is not considered a manufacturing or materials defect.**
- **This limited warranty will not reimburse you for the cost of any inconvenience, food, personal injury or property damage.**

### ITEMS MANUFACTURER WILL NOT PAY FOR:

1. Shipping cost, standard or expedited, for warranty and replacement parts.
2. Service calls to your home.
3. Repairs when your product is used for other than normal, single-family household or residential use.
4. Damage, failures, or operating difficulties resulting from accident, alteration, careless handling, misuse, abuse, fire, flood, acts of God, improper installation or maintenance, installation not in accordance with electrical or plumbing codes, or use of products not approved by the manufacturer.
5. Any food loss due to product failures or operating difficulties.
6. Replacement parts or repair labor costs for units operated outside the United States or Canada.
7. Pickup and delivery of your product.
8. Repairs to parts or systems resulting from unauthorized modifications made to the product.
9. The removal and/or reinstallation of your product.

## DISCLAIMER OF IMPLIED WARRANTIES AND LIMITATION OF REMEDIES

- Repair or replacement of defective parts is your exclusive remedy under the terms of this limited warranty. In the event of parts availability issues, the manufacturer reserves the right to substitute like or similar parts that are equally functional.
- The manufacturer will not be responsible for any consequential or incidental damages arising from the breach of either this limited warranty or any applicable implied warranty, or for failure or damage resulting from acts of God, improper care and maintenance, grease fire, accident, alteration, replacement of parts by anyone other than the manufacturer, misuse, transportation, commercial use, abuse, hostile environments (inclement weather, acts of nature, animal tampering), improper installation, or installation not in accordance with local codes or printed manufacturer instructions.
- This limited warranty is the sole express warranty given by the manufacturer. No product performance specification or description wherever appearing is warranted by the manufacturer except to the extent set forth in this limited warranty. Any implied warranty protection arising under the laws of any state, including implied warranty of merchantability or fitness for a particular purpose or use, is hereby limited in duration to the duration of this limited warranty.
- **Neither dealers nor the retail establishment selling this product has any authority to make any additional warranties or to promise remedies in addition to or inconsistent with those stated above.** Manufacturer's **maximum liability**, in any event, shall not exceed the purchase price of the product paid by the original recipient.

**NOTE:** Some states do not allow an exclusion or limitation of incidental or consequential damages, so some of the above limitations or exclusions may not apply to you. This limited warranty gives you specific legal rights as set forth herein. You may also have other rights which vary from state to state. In the state of California only, if refinishing or replacement of the product is not commercially practicable, the retailer selling this product or the Manufacturer will refund the purchase price paid for the product, less the amount directly attributable to use by the original consumer-purchaser prior to discovery of the nonconformity. In addition, in the state of California only, you may take the product to the retail establishment selling this product in order to obtain performance under this limited warranty.

Consumer returns will not be accepted unless a valid Return Authorization is first acquired. Authorized returns are clearly marked on the outside of the package with an RA number and the package is shipped freight/postage pre-paid. Consumer returns that do not meet these standards will be refused.

---

## FEATURES

- It has an exclusive exterior patent design that is perfect for low-temperature smoking. You can finish the assembly in several minutes.
- The digital control board shows cooking temperature and time, providing a better user experience.
- Its heating tube power is 800W, and the temperature setting range is 100°F to 275°F (38°C to 135°C), with an internal capacity that can accommodate 2 turkeys, 4 pork forelegs, 4 ribs, or 6 chickens.
- In addition, it also has a side wood chip loading box that can sustain smoke for 4-6 hours without frequent refilling.
- It also has a double-layer iron plate + internal foam filling that completely isolates the body, maintaining internal heat and preventing smoke from escaping.
- Finally, it has 4 layers of chrome-plated grill nets, with a total barbecue area of 725 square inches.

---

## WARRANTY POLICY

### GUARANTEED 3-YEAR WARRANTY

Thank you for choosing East Oak. This product is covered by our company warranty for up to 3 years from its original purchase date.

### CLAIM WARRANTY

If you'd like to claim your product's warranty, register your new product on our website at [www.eastoak.com/warranty](http://www.eastoak.com/warranty).

---

## WARNING

Cancer and reproductive Harm  
[www.P65Warnings.ca.gov](http://www.P65Warnings.ca.gov).

# EAST OAK

✉ [support@eastoak.com](mailto:support@eastoak.com)

🌐 [eastoak.com](http://eastoak.com)

☎ 1-833-EAST-OAK (USA)