

30" Digital Electric Smoker Pro Owner's Manual

MODEL:

PES23001



EAST OAK



Need help starting?

Scan the QR code to watch our installation video.



installation video



Unlock all the perks! Register now to activate your 3-year warranty.

Scan the QR code within 90 days to visit our registration page. Fill in the Unique Product ID and required information as instructed.

Complete the registration!

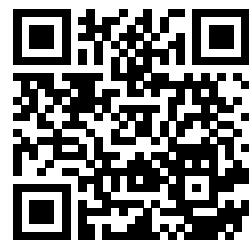
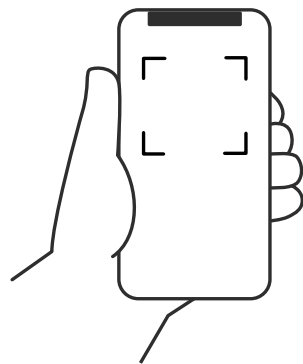

eastoak.com/warranty



Uncover New Tricks & Join the Conversation!

Scan the QR code to access our official recipe collection.

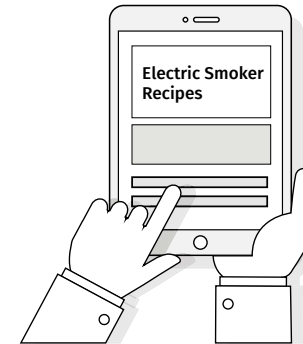

Questions? Comments? Reach out to us for expert support!

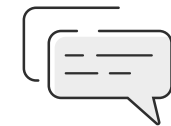

✉ support@eastoak.com
🌐 eastoak.com
☎ 1-833-EAST-OAK (USA)
(1-833-327-8625) 9am-7pm EST Mon-Fri



Welcome to the East Oak family!

Stay updated with our latest news and exclusive discounts by following us on social media!



Facebook [@eastoakliving](https://www.facebook.com/eastoakliving)
www.facebook.com/eastoakliving



Instagram [@eastoakliving](https://www.instagram.com/eastoakliving)
www.instagram.com/eastoakliving/



Youtube [@eastoakliving2080](https://www.youtube.com/@eastoakliving2080)
www.youtube.com/@eastoakliving2080

IMPORTANT INFORMATION

Please check all parts and components to ensure no damage or missing items before starting the product's construction. If you have any problems or discover any missing parts, please contact customer service at support@eastoak.com.

- Some parts may contain sharp edges. Wear protective gloves if necessary during assembly.
- When using power tools, please use the lowest power setting to avoid damage to the parts.
- Assemble on a soft surface such as a drop sheet or rug to avoid scratching.
- **The handle screws are pre-installed on the smoker body. Please check carefully when unpacking. If any screws appear missing, contact customer service immediately.**

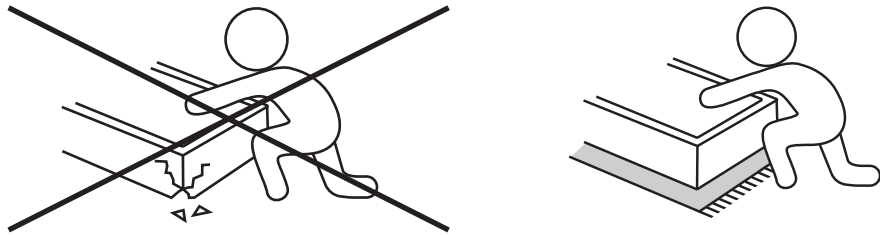

! DANGER CARBON MONOXIDE HAZARD.

- Burning wood gives off carbon monoxide which may cause death.
- **DO NOT** burn wood chips inside homes, tents, garages, or any enclosed areas.
- Use only outdoors in a well-ventilated area.

! CAUTION

- Do not use sharp or pointed tools to clean the smoker.
- Do not use abrasive oven cleaners, steel wool, or metal brushes to clean porcelain grates or smoker bodies. They will damage the finish.
- Only replace damaged parts with parts provided directly by the manufacturer. Do not attempt to repair damaged parts.

! WARNINGS AND IMPORTANT SAFEGUARDS

READ ALL INSTRUCTIONS BEFORE USE General Safety Precautions

Setup

- Do not plug in the smoker until fully assembled and ready for use.
- Do not use the smoker during an electrical storm.
- It is recommended to keep children and pets away from smokers.
- The use of accessory attachments not recommended by the appliance manufacturer may cause injuries.
- Do not use this appliance other than for its intended use. This unit is for OUTDOOR HOUSEHOLD USE only and is NOT for commercial use.
- This unit is not to be used as a heater (see carbon monoxide danger warning on cover/page 2).
- The smoker box is intended for wood chips only. Do not use wood chunks or pellets. NEVER use charcoal inside the smoker or smoker box, as it will cause a fire, create unsafe conditions, and damage the smoker.

Positioning

- Do not place the smoker on or near a hot gas or electric burner or in a heated oven.
- To prevent the smoker from being splashed or falling into the water, do not use the smoker within 10 feet of a pool, pond, or other body of water.
- Never use it inside enclosed areas, such as garages, buildings, or tents.
- Do not operate under overhead construction, such as roof coverings, carports, awnings, or overhangs.
- Use the unit on a level, non-combustible stable surface such as dirt, concrete, brick, or rock.
- The unit **MUST** be on the ground. Do not place it on tables or counters. Avoid moving it across uneven surfaces.
- Keep the unit at least 36" (92cm) away from walls or railings.
- Do not use or store gasoline, kerosene, or other flammable liquids within 20' (6m) of the smoker when in use.
- Keep the smoker and electric controller dry and out of the rain at all times.

Use

- Surfaces may be hot, so avoid touching hot surfaces directly with any part of your body.
- Use long-handled barbecue utensils and protective gloves when adding or removing food to avoid burns.
- Never leave the smoker unattended when it is on.

WARNINGS AND IMPORTANT SAFEGUARDS

General Use

- Do not use glass, plastic, or ceramic cookware inside the smoker.
- Do not leave wood ashes in the smoker box. Empty it after each use and dispose of cold ashes by placing them in aluminum foil, soaking them with water, and discarding them in a non-combustible container.

Cords

- Use only with a GFI (Ground Fault Interrupter) protected circuit, and use only on a properly grounded outlet.
- Do not operate any appliance with a damaged cord or plug or after the appliance malfunctions or has been damaged in any manner.
- To protect against electrical shock, do not immerse the cord, plugs, controller, or heating element in water or any other liquid. Keep the plug off the ground and dry.
- Do not let the cord hang over the edge of a table or counter, and do not let it touch hot surfaces.
- Never remove the grounding plug or use it with an adapter having only two prongs.
- To disconnect, turn the control panel "OFF" and remove the plug from the outlet.
- If a longer detachable power-supply cord or extension cord is used: (1) the marked electrical rating of the cord set or extension cord should be at least as great as the electrical rating of the appliance, and (2) the cord should be arranged so that it will not drape over the counter or portable top where it can be pulled by children or tripped over unintentionally. The extension cord must be a grounding-type 3-wire cord.

Other

- Do not use water or other liquid sprays to clean the product without first unplugging the electric controller and removing the heating element.
- Keep a fire extinguisher accessible during operation.
- Allow it to cool before putting on or taking off parts.
- This is a smoker, so there will be a lot of smoke produced when using wood chips. Smoke will escape through seams and turn the inside of the smoker black. This is normal.

WARNING

- This manual contains important information necessary for the proper and safe use of this unit.
- Read and follow all warnings and instructions before using smoker and during use.
- Keep the manual for future reference. Some parts may have sharp edges. Handle with care and wear protective gloves if needed.
- Failure to follow all manufacturer's safeguards could result in serious personal injury and property damage.
- Read and follow all the information and safeguards in this product guide before attempting to assemble or operating this smoker.
- The smoker should only be rolled on a smooth surface. Never roll the smoker up or down stairs or on uneven surfaces, as this could potentially damage the smoker and hurt the user.



DANGER Extension Cord Use

DO NOT USE 16 OR 18 GAUGE EXTENSION CORDS.

MISUSE MAY DAMAGE HOUSEHOLD WIRING OR CAUSE A FIRE.

For best smoker performance, using an extension cord is not recommended. If you must use an extension cord, the following is required for your safety:

- Use only an outdoor type with a 3-prong grounding plug, rated for 15 amperes or more, approved by UL, marked with a W-A, and a tag stating "Suitable for Use with Outdoor Appliance".
- Use the shortest length extension cord required. Never connect multiple extension cords together.
- Keep connections dry and off the ground.
- Do not let the cord hang over the edge of a table top or other items where it can be pulled by children or tripped over.

Ground Fault Interrupter:

- Since 1971 the National Electric Code (NEC) has required Ground Fault Interrupter devices on all outdoor circuits.
- If your residence was built before 1971, check with a qualified electrician to determine if a Ground Fault Interrupter protector exists.
- Do not use this appliance if the circuit does not have GFI protection.
- Do not use this appliance with indoor-only circuits.

PARTS LIST

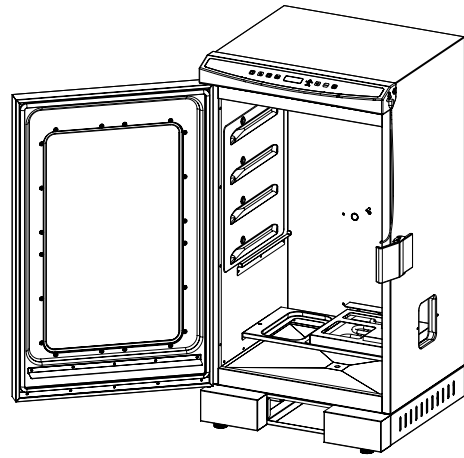

Smoker Assembly

A X 1 PC



Back Handle

B X 1 PC

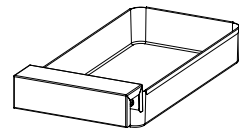

Grease Tray

C X 1 PC

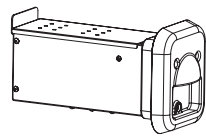

Smoker Box

D X 1 PC



Water Pan

E X 1 PC

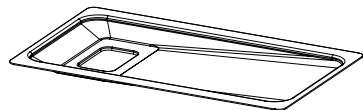

Drip Pan

G X 1 PC

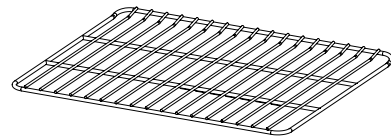

Cooking Rack

F X 4 PCS

PARTS LIST

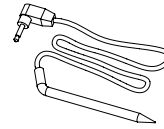

Meat Probe

I X 1 PC

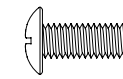

M6*15 Screws

L X 2 PCS

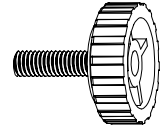

Leg Boot

H X 4 PCS

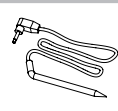

TIPS: The meat probe is located in the right-side compartment of the smoker after opening the door.

WHAT'S IN THE BOX

- 1 X Smoker Assembly
- 1 X Back Handle
- 1 X Grease Tray
- 1 X Smoker Box
- 1 X Water Pan
- 1 X Drip Pan
- 4 X Cooking Racks
- 1 X Meat Probe
- 2 X Screws
- 4 X Leg Boots
- 1 X Owner's Manual

ASSEMBLY INSTRUCTIONS

1 Turn the smoker upside down and install the four leg boots (H) onto the base.

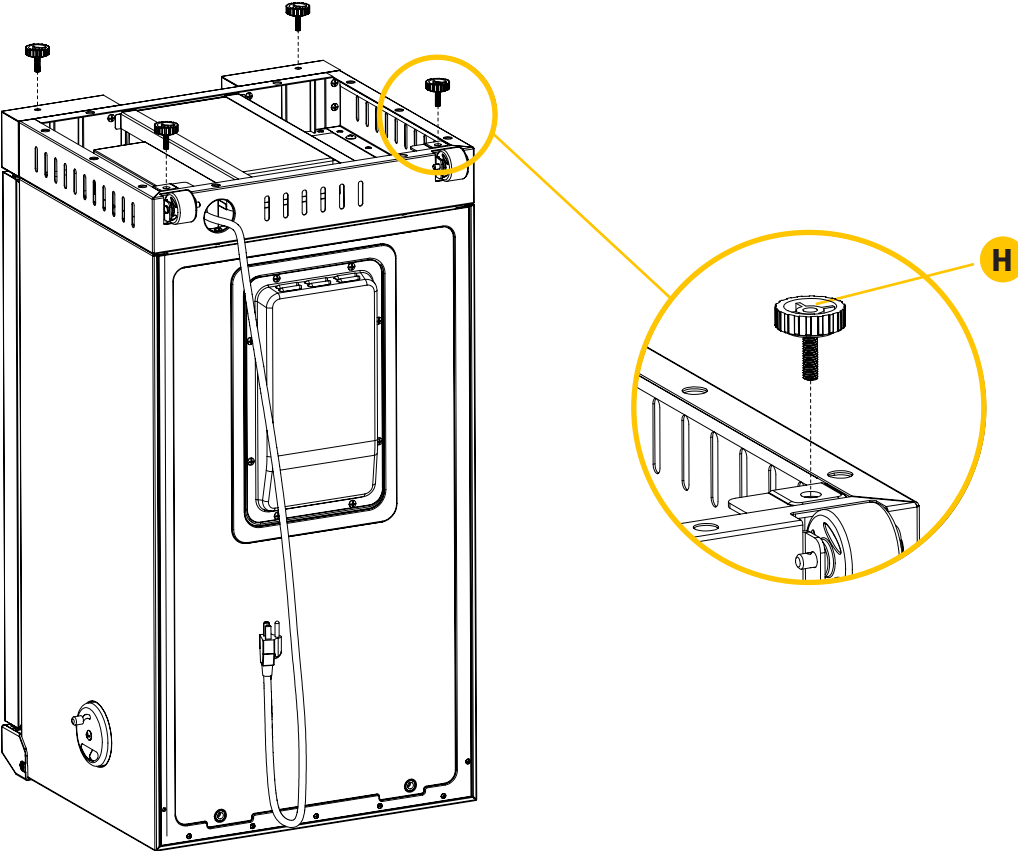

2 Stand the smoker upright and install the handle (B) on the back of the smoker using the two M6*15 screws (L).

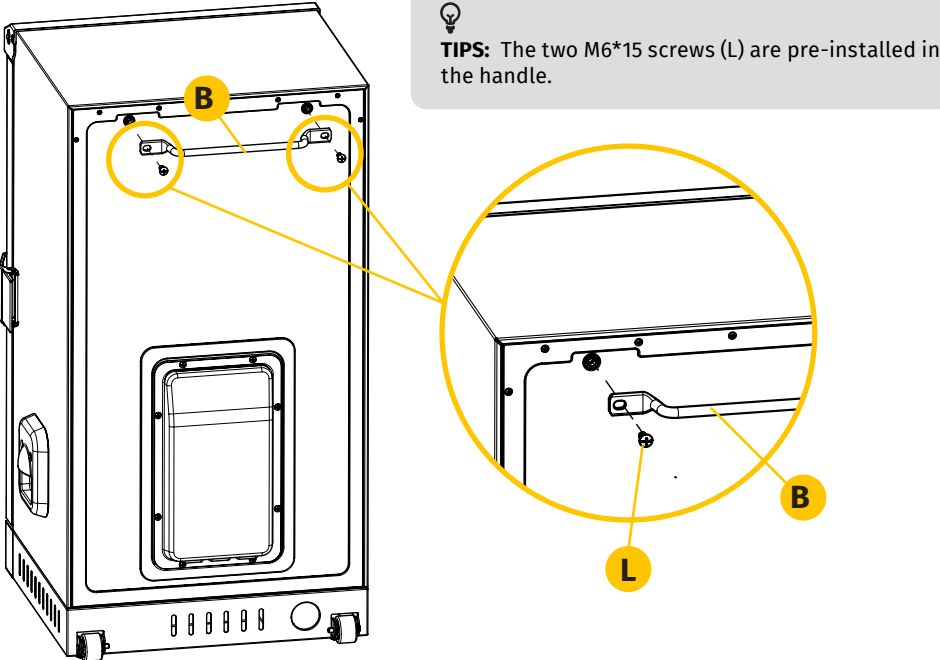

3 Push the grease tray (C) between the right and left decorative plates. It should snap into place when fully inserted.

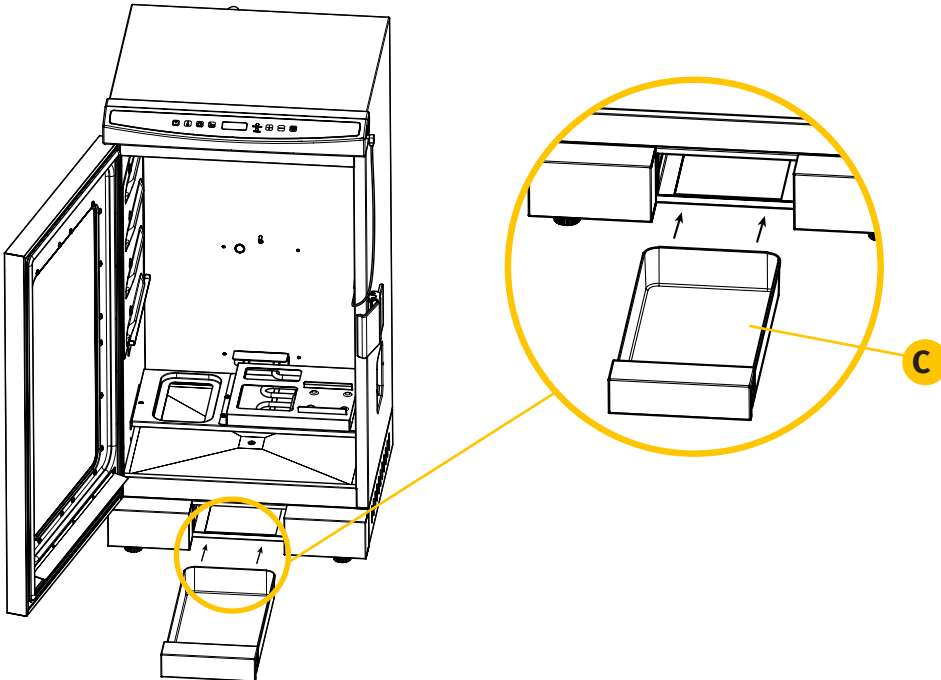

4 Place the water pan (E) and smoker box (D) into their designated positions inside the smoker.

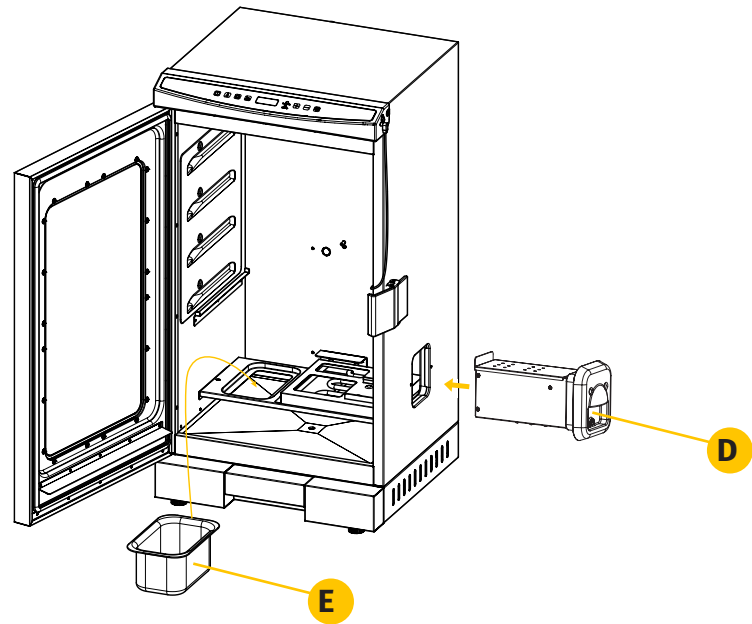

5 Place the drip pan (G) into the brackets on both sides of the smoker chamber.

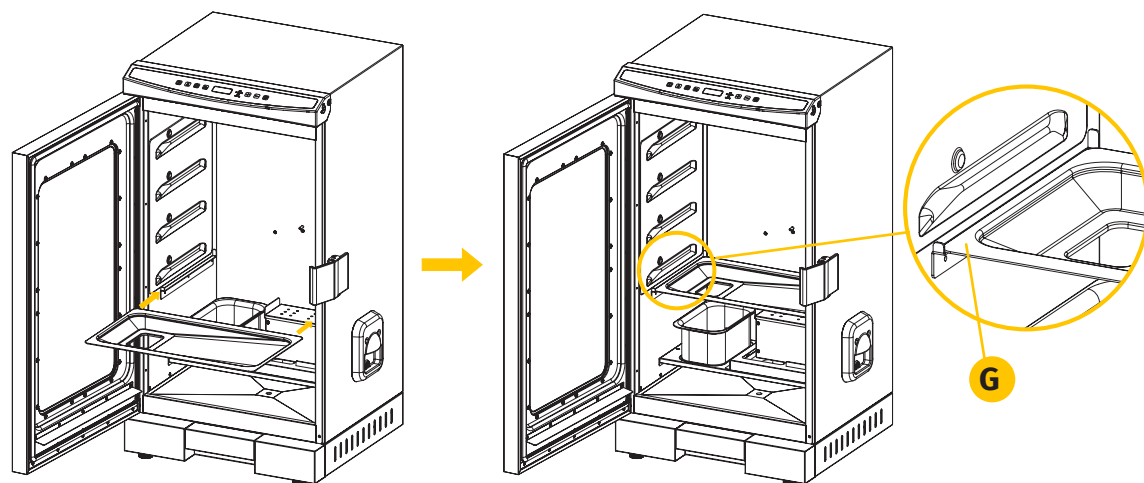

6 First, place the temperature probe (I) onto the fixed plate on the left chamber wall. Then, remove the waterproof cover from the meat probe socket by pulling it out and unscrewing it clockwise to reveal the jack. Firmly insert the meat probe into the jack to ensure proper connection.

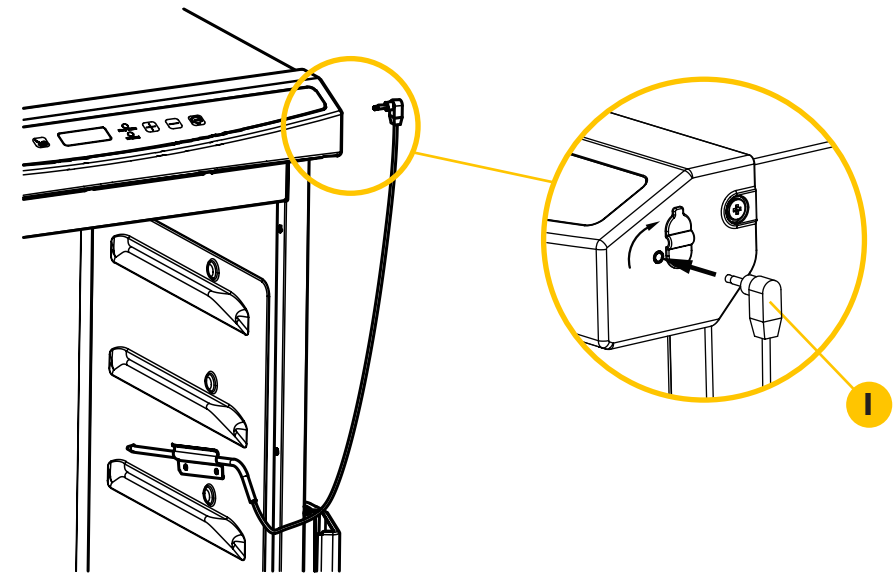

7 Insert the cooking racks (F) into the brackets on both sides of the smoker.

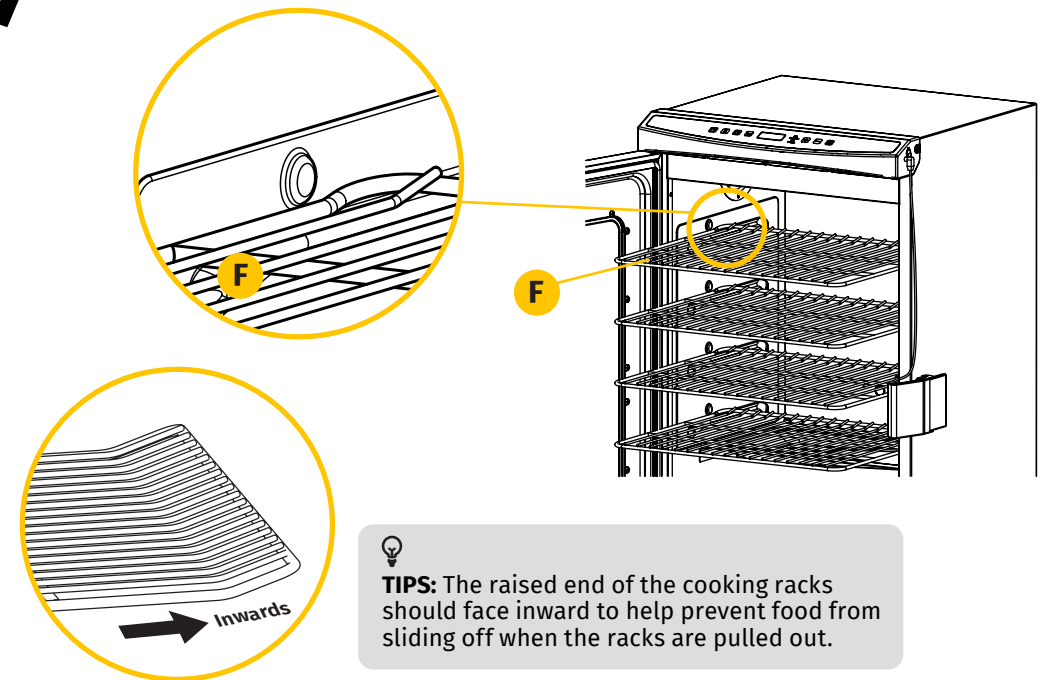

TIPS: The raised end of the cooking racks should face inward to help prevent food from sliding off when the racks are pulled out.

PARTS DIAGRAM

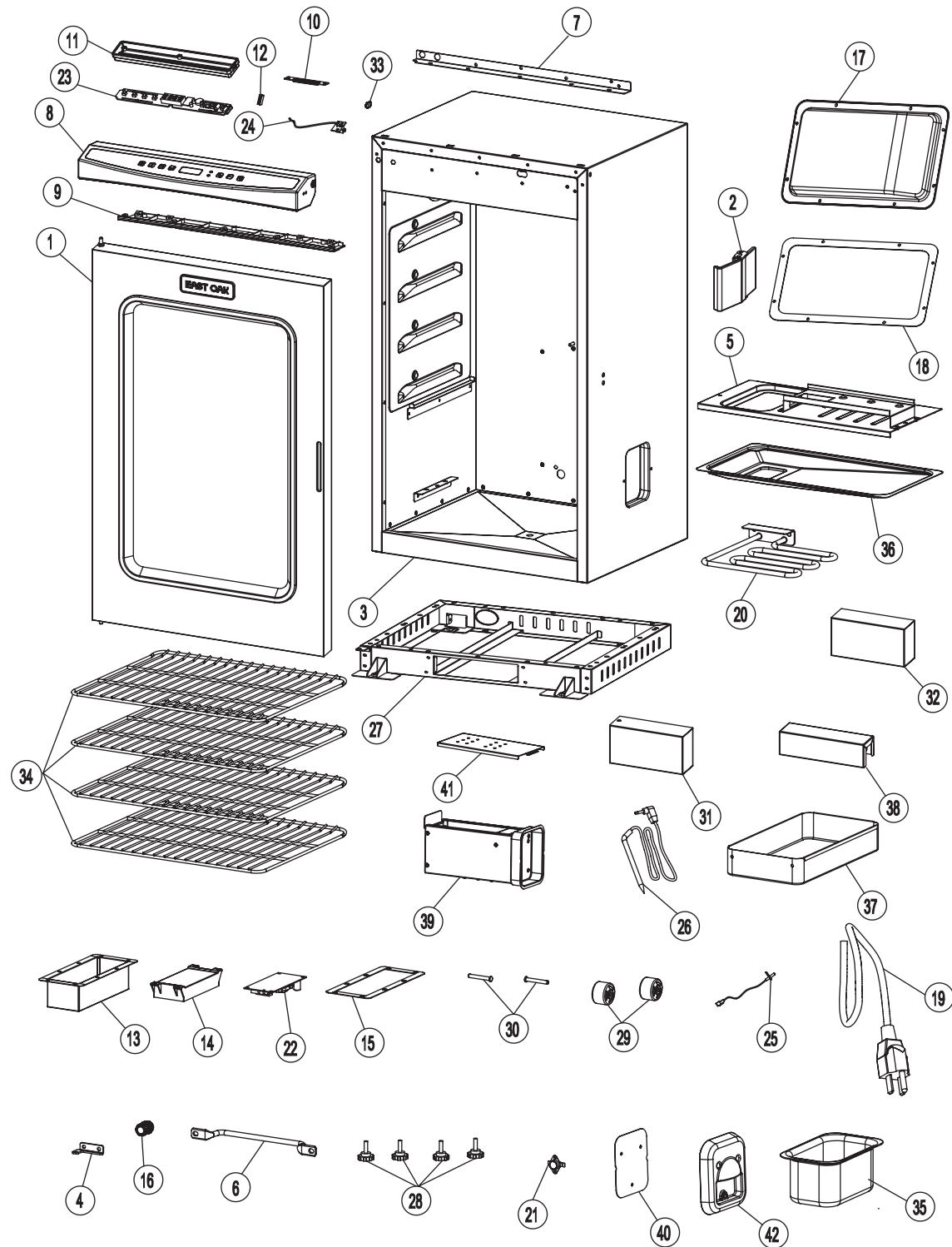

PARTS LIST







ITEM NO.	QUANTITY	DESCRIPTION
1	1	DOOR ASSEMBLY
2	1	DOOR LATCH KIT
3	1	SMOKER BODY ASSEMBLY
4	1	DOOR TOP HINGE BRACKET KIT
5	1	HEATING ELEMENT REFLECTOR
6	1	BACK HANDLE
7	1	CONTROL PANEL FRAME BRACKET
8	1	CONTROL PANEL FASCIA KIT
9	1	CONTROL PANEL BOTTOM PLATE
10	1	LIGHT COVER
11	1	CONTROL PANEL HOUSING
12	1	CONTROL PANEL HOUSING OUTLET SEALING
13	1	POWER BOARD HOUSING
14	1	POWER BOARD GASKET
15	1	POWER BOARD HOUSING GASKET
16	1	POWER CORD METAL LOCK
17	1	REAR HEATING ELEMENT COVER
18	1	REAR HEATING ELEMENT COVER GASKET
19	1	POWER SUPPLY CORD KIT
20	1	HEATING ELEMENT
21	1	THERMOSTAT KIT
22	1	POWER BOARD KIT
23	1	CONTROL PANEL DISPLAY KIT
24	1	MEAT PROBE CONNECTION FEMALE PLUG KIT
25	1	CHAMBER TEMPERATURE PROBE KIT
26	1	MEAT PROBE
27	1	BASE WELDING ASSEMBLY
28	4	LEG BOOT
29	2	WHEEL KIT
30	2	AXLE KIT
31	1	LEFT DECORATIVE PANEL
32	1	RIGHT DECORATIVE PANEL
33	1	WATERPROOF COVER FOR MEAT PROBE JACK
34	4	COOKING RACK
35	1	WATER PAN

PARTS LIST

ITEM NO.	QUANTITY	DESCRIPTION
36	1	DRIP PAN
37	1	GREASE TRAY
38	1	GREASE TRAY HANDLE
39	1	SMOKER BOX
40	1	RIGHT END HEAT INSULATION COVER
41	1	SMOKER BOX LID
42	1	SMOKER BOX HANDLE

CONTROL PANEL OPERATING INSTRUCTIONS



-  **Power Button - Turns smoker on and off**
-  **Temp Button - Adjusts Cooking temperature**
-  **Time Button - Adjusts Cooking time**
-  **Meat Probe Button - Press and hold to display internal temp of meat**
-  **Up Button - Increases time or temperature**
-  **Down Button - Decreases time or temperature**
-  **Chamber Light - On/Off**

Display: The digital control panel is used to display the temperature setting value and actual measurement value in the chamber, the cooking timing time value, the countdown remaining time value, and the error code.

Power indicator light: This indicator light is a green LED light. When the indicator light is on, the control program enters the “heat preservation and temperature control” state.

Heating indicator light: The indicator light is a red luminous LED light. When the indicator light is on, the control program has entered the “heating work” state.

GENERAL OPERATION INSTRUCTIONS

Display

1. Press the Power Button once to ready the device to receive inputs for the Temp/Time settings.
2. Time is displayed in 00:00 (HH:MM) with a range of 00:00 - 12:00 hours.
3. Temperature can be displayed in °F or °C, with the default set to °F. The Temp cooking mode range is 100°F - 275°F(38°C- 135°C) and the Meat Probe temperature range is 32°F to 302°F(0°C to 150°C). To switch between °F and °C, simultaneously press the UP and DOWN buttons for 3 seconds after powering on and PRIOR to any operation. Once settings are adjusted for Temp/Time/Meat Probe it is not possible to switch.
4. The heating element will not begin to heat up until the Temp and Time settings are input. If the meat probe is not connected to the smoker the meat probe function is automatically disabled.
5. If no operation is performed for 12 hours the unit will automatically shut down and the display screen will turn off.

Temp Button

1. Press the Temp Button to initiate temperature selection, the default setting will show 210°F (99°C) and will blink to indicate the temperature is ready to be adjusted.
2. Press and hold the Up or Down button to raise or lower the desired cooking temperature then release the button when the desired temperature is shown.
3. Press the Temp Button again to fix the setting, the display will no longer blink.

Time Button

1. Press the Time Button to initiate time selection, the default setting will show 00:00 and will blink to indicate the time is ready to be adjusted.
2. Hours and minutes are adjusted independently. Press and hold the Up or Down button to adjust the hour setting, release to stop. Press the Time Button again to switch to minutes and repeat the process for minutes. Once set, press the Time Button one final time to begin the cooking. The blinking will stop, and the time will begin to count down indicating the cooking has begun.
3. During cooking the display will alternate between the actual smoker temperature and the actual time elapsed.

4. Once the time has elapsed, the temperature of the device will be automatically reduced to 120°F (49°C) and the display will alternate between 00:00 and 120°F. An audible beep will sound three beeps and then three beeps every 30 seconds until the power button is pressed, If no operation for 12 hours is performed the device will automatically shut off.

Meat Probe Button

1. Insert the meat probe into the center of the meat for the most accurate reading.
2. Press and hold the Meat Probe button to display the internal temperature of the meat.
3. Once the Meat Probe button is released the display will return back to the set temperature or set time.

Smoker Box

The Smoker Box is where wood chips are added to bring smoke flavor to your food.

1. The Smoker Box is designed for wood chips, do not use wood chunks or pellets. NEVER use charcoal inside the smoker or Smoker Box as it will cause a fire, create unsafe conditions, and damage the smoker.
2. If wood chips are not being used as part of the cooking process, it is still required to have the Smoker Box inserted during the entire cooking process.
3. Always wear heat-resistant gloves when adding wood chips to avoid burns.

Water Pan

The Water Pan helps keep meat moist by retaining moisture inside the smoker during cooking.

1. Fill the Water Pan with warm water to the max line prior to pre-heating and cooking. Do not overfill the Water Pan. Never remove or refill the Water Pan while cooking.
2. It is very important not to let any liquid come into contact with the heating element to avoid serious damage including injury, flare ups, and electrical failure. ALWAYS wear anti-scalding gloves when opening and working in the smoker after it is turned on.

Chamber Light

1. Press the Chamber Light button once to illuminate the light, then press it again to turn it off.
2. The light will automatically turn off after ten minutes.

Cleaning the Smoker (First-Time Use)

Prior to the smoker's first use, and after completion of the Assembly Instructions, the smoker must be seasoned to remove any residue: (such as oil and dust) which may have been left over from the manufacturing process. Please follow the instructions below:

1. Using a damp sponge and mild detergent, carefully wipe down all interior surfaces of your smoker, including trays and racks, ensuring not to scratch any surfaces. Rinse off any soapy residue with water and allow the unit to air dry with the smoker door open.
2. Apply a light coating of cooking oil spray or a small amount of cooking oil on a cloth and wipe down the inside of the smoker, excluding the smoker box, heating element, grease tray, and water pan.
3. Ensure the water pan is in place without water and the smoker box is in place without wood chips. Open the vent fully and keep it open during the cleaning process.
4. Plug in the appliance; the display will power up immediately and emit a beep sound.
5. Press the Power Button once to activate the control unit.
6. Press the Temp Button and set the temperature to 275°F (135°C), the maximum setting.
7. Press the Time Button and set the time to two hours.
8. Once two hours have passed, power off the smoker and allow it to cool down.
9. After completing the cleaning process and once the smoker has cooled down, it's ready to use.



The smoker is TOO HOT to touch during use. Please remember to wear protective gloves before use.

Preheating the Smoker



Preheat the smoker for 60-75 minutes (to max temp) before cooking. Always make sure the water pan is filled before preheating.

1. Press the Temp Button and set the temperature to 275°F (135°C), the max setting.
2. Press the Time Button and set the time to 60-75 minutes.
3. After the Smoker has reached the max temperature, it is ready for use.

Cooking With the Smoker

1. After cleaning (if first-time use) and preheating the smoker as described above, it is now ready for use. Remember, as part of the preheating setup, ensure that wood chips and water are already inserted into the Smoker Box and Water Pan.
2. Carefully insert the meat into the preheated smoker, using protective gloves and ensuring not to overfill the space. Maintaining space between the meat and around the edges of the racks ensures proper air circulation.
3. Set the cooking temperature using the Temp Button and then choose either the Time function or the Meat Probe temperature. Refer to the operating instructions in the related sections on page 16 for each function.
4. Once the internal temperature of the meat meets or exceeds the recommended USDA guidelines displayed earlier in this manual, power off the device. Remove the meat from the smoker and enjoy your perfectly cooked meal!

Reminder:

Never rely solely on cooking time. Always ensure food reaches the minimum internal temperature recommended by the USDA for safe consumption.

Food Safety

Safe handling, cooking, and storage steps are vital for preventing foodborne illness. Harmful bacteria that can cause illness are invisible, odorless, and tasteless. At every stage of food preparation, it's crucial to follow the four guidelines to keep food safe:

- **Clean** — Wash hands and surfaces often.
- **Separate** — Keep raw meat separate from other foods.
- **Cook** — Ensure food is cooked to the right temperature.
- **Chill** — Refrigerate food promptly.

USDA Recommended Internal Cooking Temperatures

- Meat and poultry cooked on a grill may brown quickly on the outside but could remain undercooked inside. Avoid partially grilling meat or poultry with the intention of finishing cooking later. Color alone is not a reliable indicator of safety and doneness. Always use a food thermometer to ensure the food reaches a safe minimum internal temperature. Insert the thermometer into the thickest part of the food, avoiding contact with fat, gristle, or bone. Remember to wash the food thermometer thoroughly with hot, soapy water before and after each use.
- When checking the temperature of ground beef or poultry burgers, insert the food thermometer through the side of the patty until the probe reaches the center to detect any cold spots. Ground beef burgers should reach 160°F, while ground poultry burgers should reach 165°F for safe consumption.
- Cook all food to these minimum internal temperatures as measured with a food thermometer before removing food from the heat source. For reasons of personal preference, consumers may choose to cook food to higher temperatures.

PRODUCT	MINIMUM INTERNAL TEMPERATURE & REST TIME
Beef, Pork, Veal & Lamb Steaks, Chops, Roasts	145° F(62.8° C) and allow to rest for at least 3 minutes
Ground Meats	160°F(71.1°C)
Ground Poultry	165°F(73.9°C)
Ham, fresh or smoked (uncooked)	145° F(62.8° C) and allow to rest for at least 3 minutes
Fully Cooked Ham (to reheat)	Reheat cooked hams packaged in USDA-inspected plants to 140°F(60°C) and all others to 165°F(73.9°C)
All Poultry (breasts, whole bird, legs, thighs, wings,ground poultry, giblets, and stuffing)	165°F(73.9°C)
Eggs	160°F(71.1°C)
Fish & Shellfish	145°F(62.8°C)
Leftovers	165°F(73.9°C)
Casseroles	165°F(73.9°C)

Visit <https://www.fsis.usda.gov> for more information on Food Safety.

Care Instructions

- Clean rack supports, racks, water bowl, and drip pan with mild dish detergent. Rinse and dry thoroughly.
- Clean the interior frame, door glass (if present), meat probe, and exterior of the smoker with a damp cloth only. If necessary, you can use a neutral and mild cleaning agent and then rinse off any soapy residue with water and allow the unit to air dry with the smoker door open. Dry thoroughly.
- After each use, clean the door seal and the corresponding inside seam with a damp cloth to preserve the life of the seal.
- Always take care not to scratch any surfaces inside or outside the unit to reduce the chance of rust or corrosion.
- Avoid cleaning any of the smoker surfaces while hot.
- The Smoker Box should be cleaned frequently to remove ash, residue, and dust.



HELPFUL TIPS

- **Avoid covering racks with aluminum foil, as it may inhibit proper heat circulation.**
- **Both dry and pre-soaked chips are suitable for use in the smoker. Dry chips are preferred as they burn faster, producing a more intense smoke. Pre-soaked chips (approx. 30 min) burn slower and produce milder smoke.**



HELPFUL TIPS

- In cooler outside temperatures below 65°F (18°C) and/or at altitudes above 3,500 feet (1,067m), additional cooking time may be necessary.
- Avoid overloading the smoker with food. Ensure there is space between the food items and around the edges of the rack to facilitate heat circulation.
- Refrain from overpacking the Smoker Box with wood chips, and do not exceed the max fill line when filling the Water Pan.
- Always use the Water Pan and Smoker Box, regardless of whether they are filled, during cooking.
- Minimize opening the smoker door during operation, as it can lead to heat loss and prolong cooking times.
- Excessive food in the smoker can disrupt heat convection due to the bottom placement of the heat source. This may lead to uneven heat distribution within the chamber, causing the actual temperature to deviate from the set temperature. To ensure proper heat circulation and convection, it's advisable to use an appropriate amount of food, allowing sufficient space between items.

Meat Smoking Flavor Profiles & Pairings

WOOD	STRENGTH	RECOMMENDED PAIRING
Hickory	Intense	Beef, Pork
Mesquite	Intense	Beef, Pork
Oak	Medium	Pork, Beef, Poultry
Maple	Mild	Poultry, Vegetables, Cheese
Apple	Mild	Pork, Poultry, Fish
Cherry	Mild	Pork, Poultry, Beef, Lamb, Duck

Note: Occasionally, condensation may accumulate on the glass door, which is a normal occurrence. Factors such as smoker placement, outdoor temperature, water levels in the pan, venting, and lower cooking temperatures can contribute to this effect. If you notice liquid seeping from the bottom of the unit, it's likely just condensation, not oil or grease. Please remember to use this appliance only outdoors in a secure area away from children and animals.

Note: You have the option to use either dry or pre-soaked wood chips in your smoker. Dry chips will burn faster, resulting in a more intense smoke flavor. On the other hand, chips that have been pre-soaked in water for approximately 30 minutes will burn more slowly, producing a milder smoke flavor.

TROUBLESHOOTING		
ISSUE	POSSIBLE CAUSE	RECOMMENDED PAIRING
Smoker noheating	Smoker is not plugged in fully.	Remove plug from outlet and plug in again.
	No power.	Turn the Smoker OFF and unplug from outlet. Check or replace in this order: <ul style="list-style-type: none"> • Check for tripped household circuit breakers or Ground Fault Circuit Interrupter (GFCI). Reset or replace if necessary using a GFCI rated for 15 amperes or more. • Test a known, working appliance in the outlet to ensure there is no issue with the outlet itself. • Try using a different outlet, preferably on a different circuit, to rule out electrical issues. • Disconnect and reconnect the thermostat connections. Replace the Thermostat Kit if needed. • Disconnect and reconnect the control panel connections. Consider replacing the Control Panel Display Kit if the issue persists. • If necessary, disconnect and reconnect the power board connections. Replace the Power Board Kit if the problem persists.
	Faulty heating element.	Turn the Smoker OFF and unplug from outlet. Check or replace in this order: <ul style="list-style-type: none"> • Unplug heating element connections and reconnect. • Replace the heating element. • Replace the Thermostat kit. • Replace the Control Panel Display Kit. • Replace the Power Board Kit.
Circuit breaker trips or fuse blows	Another appliance plugged into same circuit as the smoker.	Remove all other electrical appliances on the same circuit, then try again.
	Faulty heating element.	Remove all other electrical appliances on the same circuit, then try again.
	Poor electrical connections.	Turn the Smoker OFF and unplug from outlet. Check or replace in the following this order: <ul style="list-style-type: none"> • Unplug thermostat connections and reconnect. Replace the Thermostat Kit if necessary. • Replace the Power Supply Cord Kit.
No display	Faulty control panel.	Turn the Smoker OFF and unplug from outlet. Check or replace in the following this order: <ul style="list-style-type: none"> • Unplug the smoker and plug it back into the outlet (a beep will sound when plugged in). • Unplug thermostat connections and reconnect. Replace Thermostat Kit if necessary. • Unplug control panel connections and reconnect, Replace the Control Panel Display Kit if necessary. • Unplug power board connections and reconnect. Replace the Power Board Kit if necessary.
Smoker will not cook properly	Door of smoker is left open.	Keep the smoker door closed while cooking to prevent rapid heat loss. Opening the door allows heat to escape quickly, which can prolong the cooking time needed to properly cook your food.
	Insufficient preheat.	Always use controller PH (preheat) setting before starting a cooking.
	Inappropriate extension cord.	Use only outdoor extension cords with a 3-prong grounding plug that are rated for 15 amperes or more and approved by UL. Look for cords marked with a "W-A" and a tag stating "Suitable for Use with Outdoor Appliance." Use the shortest length extension cord necessary and avoid connecting two or more cords together. For optimal safety, use a 12 or 14 gauge extension cord that is 50ft. or shorter.
Flare-ups	Excess fat in meat.	Trim fat from meat before cooking.
	Excessive cooking temperature.	Adjust (lower) temperature as needed.
	Grease build up.	Clean smoker, cooking grates, drip pan, grease tray and water pan.
Persistent grease fire	Grease trapped by food build up.	Turn the Smoker OFF and unplug from outlet, Keep door open and let fire burn out.
		Do not apply water to grease fire. Doing so may cause the fire to spread or result in injury.
		After smoker cools, clean smoker, cooking grates, drip pan, grease tray and watelpan.

ERROR CODES		
ERROR CODES	ISSUE	RECOMMENDATION
Err1	Alarm sounding with 3 beeps every 30 seconds and will only stop when the Power Button is turned to off. Blinking "Err1" appears when you press the Power Button when starting your smoker. The "Err1" code blinks when pressing the Temp Button on your smoker. Blinking "Err1" appears when you press any buttons on your smoker. Refer to online Electrical Replacement Manual for instructions on removal and replacement.	Turn Smoker OFF and unplug from outlet, Replace Thermostat Kit.
Err2	Alarm sounding with 3 beeps every 30 seconds and will only stop when the Power Button is pressed Blinking "Err2" appears when you press the Power Button when starting your smoker. Blinking "Err2" appears when you preheat your smoker.	Turn Smoker OFF and unplug from outlet Check or replace in this order 1. Replace Thermostat Kit. 2. Replace Control Panel Display Kit. 3. Replace Power Board Kit.
Err3	Blinking "Err3" appears when you press the Meat Probe Button after starting your smoker. Blinking "Err3" appears when you press the Meat Probe Button when you want to check the food temperature.	Turn Smoker OFF and unplug from outlet Check or replace in this order 1. Replace Meat Probe. 2. Replace Meat Probe Housing. 3. Replace Control Panel Display Kit.
Err4	After starting your smoker. Blinking "Err4" appears when you press the Meat Probe Button when you want to check the food temperature. Blinking "Err4" appears when you press the Meat	Turn Smoker OFF and unplug from outlet Check or replace in this order 1. Replace Meat Probe. 2. Replace Meat Probe Housing.

WARNING:

- Any alterations or modifications to this unit that have not been expressly approved by the responsible party for compliance may void the user's authority to operate this equipment.
- This equipment has undergone testing and complies with the standards for a Class B digital device, as outlined in Part 15 of the FCC Rules. These standards are intended to offer reasonable protection against harmful interference in residential installations.
- This equipment utilizes and emits radio frequency energy, and if not installed and operated in accordance with the manufacturer's instructions, it may cause interference that disrupts radio communications.
- While efforts have been made to minimize interference, there is no guarantee that interference will not occur in certain installations. If this equipment disrupts radio or television reception, the user is advised to attempt corrective measures, including:
 - Adjusting or relocating the receiving antenna.
 - Increasing the distance between the equipment and receiver.
 - Connecting the equipment to a different electrical circuit than the one used by the receiver.
- If issues persist, it is recommended to seek assistance from the dealer or a qualified radio or TV technician.

FCC Notice

This device complies with Part 15 of the FCC and RSS Rules.

Operation is subject to the following two conditions:

1. This device is designed not to generate harmful interference.
2. This device is required to accept any interference received, including interference that may cause undesired operation.

LIMITED WARRANTY

- The manufacturer warrants to the original consumer-purchaser that this product will be free from defects in workmanship and materials after proper assembly and under normal use, for the period specified below, beginning on the date of purchase. The manufacturer reserves the right to require that defective parts be returned—postage and/or freight prepaid by the consumer—for review and examination.
 - **The original recipient is responsible for all shipping charges for parts replaced under the terms of this limited warranty.**
 - This warranty is valid only in the United States and Canada and applies only to the original owner. It is not transferable.
 - **Proof of purchase is required.**
 - This limited warranty covers only the product's functionality. It does not cover cosmetic issues such as scratches, dents, corrosion, or discoloration caused by heat, abrasives, or chemicals used during assembly or installation. Surface rust and stainless steel discoloration are also excluded. Paint and rust are not covered.
- Rust is not considered a manufacturing or materials defect.**
- **This limited warranty does not cover inconvenience, food loss, personal injury, or property damage.**

ITEMS NOT COVERED BY WARRANTY:

1. Shipping costs (standard or expedited) for warranty or replacement parts.
2. Service calls to your home.
3. Repairs when the product is used outside of normal, single-family household use.
4. Damage or failure caused by accident, alteration, careless handling, misuse, abuse, fire, floods, acts of God, improper installation or maintenance, or installation not in line with local electrical or plumbing codes or manufacturer instructions.
5. Food loss due to product failure.
6. Replacement parts or labor for units used outside the U.S. or Canada.
7. Pickup and delivery of the product.
8. Repairs to parts or systems altered or modified in any way.
9. Removal and/or reinstallation of your product.

DISCLAIMER OF IMPLIED WARRANTIES AND LIMITATION OF REMEDIES

- Under this limited warranty, the replacement or repair of defective parts is your sole remedy. If identical parts are unavailable, substitutes of equal value may be provided.
- The manufacturer is not responsible for any incidental or consequential damages, including but not limited to those caused by acts of God, misuse, abuse, commercial use, improper installation or maintenance, tampering, or use in hostile environments (e.g., severe weather). Damage from non-compliance with local codes or manufacturer instructions is also excluded.
- This is the only express warranty provided by the manufacturer. No performance specifications or product descriptions, whether oral or written, shall be considered a warranty unless specifically stated herein.
- **Neither dealers nor retailers selling this product have the authority to offer additional warranties or alter these terms.** Manufacturer's **maximum liability** shall not exceed the purchase price paid by the original buyer.

NOTE:

Some states do not allow exclusions or limitations on incidental or consequential damages, so these limitations may not apply to you. This warranty grants you specific legal rights, but you may also have additional rights that vary by state.

In California:

- If the product is not commercially practical, the manufacturer will refund the purchase price (less any amount attributable to the consumer's use) prior to discovering the issue.
- Alternatively, you may return the product to the retailer to obtain performance under this warranty.

Returns will only be accepted with a valid Return Authorization (RA) number. Write the RA number clearly on the outside of the package. Shipments must be prepaid. Returns that do not meet these standards will be refused.

FEATURES

- Features an exclusive patented exterior design optimized for low-temperature smoking. Assembly takes just minutes.
- The digital control board prominently displays cooking temperature and time, enhancing convenience and control.
- With an 800W heating tube and a temperature range from 100°F to 275°F (38°C to 135°C), the spacious interior can accommodate 2 turkeys, 4 pork shoulders, 4 racks of ribs, or 6 chickens.
- A side wood chip loading box allows this smoker to produce steady smoke for 4–6 hours without refilling, ensuring rich flavor throughout.
- The double-layer iron plate and internal foam insulation help retain heat and minimize smoke loss.
- Four chrome-plated grill racks offer a generous 725 square inches of cooking space — perfect for all your barbecue needs.

WARRANTY POLICY

GUARANTEED 3-YEAR WARRANTY

Thank you for choosing East Oak. This product is backed by our company warranty for up to 3 years from the original purchase date.

CLAIM WARRANTY

To claim your warranty, register your new product at: www.eastoak.com/warranty.

WARNING

Cancer and reproductive Harm
www.P65Warnings.ca.gov.

EAST OAK

✉ support@eastoak.com
🌐 eastoak.com
☎ 1-833-EAST-OAK (USA)