

Cuisinart

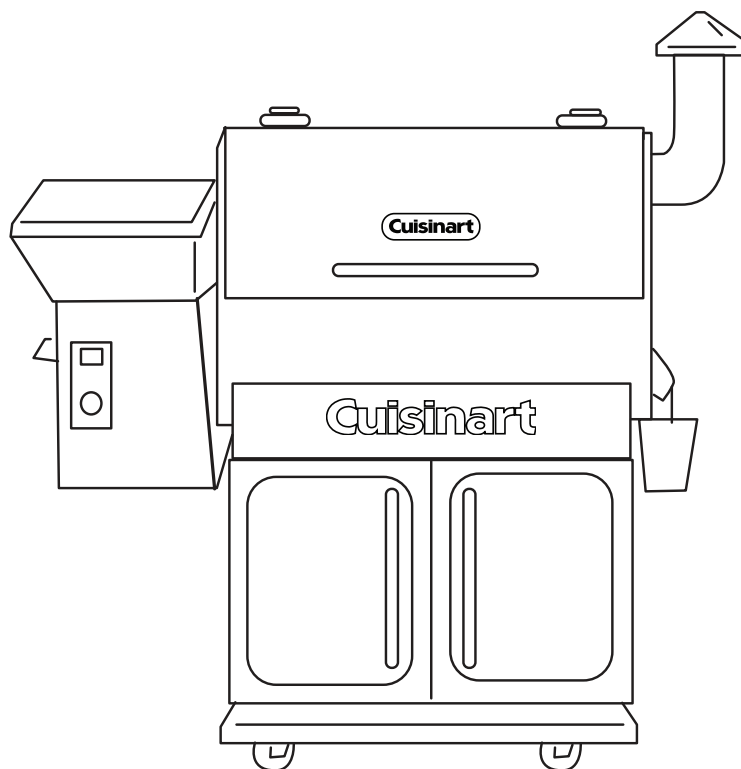

LARGE WOOD PELLET GRILL

CPG-6000

OWNER'S MANUAL

MON TO FRI, 9:00 A.M. - 5:00 P.M. EASTERN STANDARD TIME

SERVICE CONTACT: 1-866-994-6390

EMAIL: grilling@thefulhamgroup.com

CONTENTS

WARNINGS	3
COMPONENT LIST	4
ASSEMBLY INSTRUCTIONS	5
INITIAL FIRING INSTRUCTIONS	14
SUBSEQUENT START-UP	15
OPERATING TIPS	16
MAINTENANCE & CLEANING	17
TROUBLESHOOTING	19
DIGITAL THERMOSTAT CONTROL WIRING DIAGRAM	21
SUPPORT	22
3-Y LIMITED WARRANTY	23

SAVE THIS MANUAL FOR FUTURE REFERENCE

WARNINGS!

This grill is for outdoor use only. DO NOT use it in any enclosed area.

DO NOT store or use combustible materials or liquids near this appliance.

Keep children away while it is in use.

Maintain a safe distance between your grill and any combustible materials.

DO NOT move your grill while operating or while it is hot. Wait until the grill is completely cold.

If a grease fire occurs, turn “off” and leave lid closed until the fire is extinguished. DO NOT unplug the power cord. DO NOT throw water on it. DO NOT try to smother the fire.

Clean and maintain your grill after each use.

DO NOT touch any part of your grill while it is hot. Serious bodily injury could result.

We suggest the use of heat-resistant gloves when operating this grill.

We suggest that you should wrap the Grease Drain Pan with heavy-duty aluminum foil before using because it is easy to clean.

For convenient and safe assembly, use at least two people to assemble the grill.

Make sure the power cord is disconnected before performing any service or maintenance.

Always keep the Pellet Hopper dry, the wood pellets will expand greatly, break apart and even jam the feed system if the pellets get wet or are exposed to high humidity.

DO NOT place anything heavy on top of hopper lid. It is not a shelf and is a tip hazard.

COMPONENT LIST

ITEM	QTY	DESCRIPTION
1	1	Grill Chamber Assembly
2	1	Thermal Baffle
3	1	Hopper Bottom Assembly
4	1	Body Frame
5	1	Heat Baffle
6	1	Grease Drain Pan
7	1	Warming Rack
8	1	Porcelain Grills
9	1	Lid
10	2	Hinge Assembly
11	2	Hinge Pin
12	1	Lid Handle
13	1	RTD Temperature Probe
14	1	Chimney Cap Assembly
15	1	Smoke Stack Assembly
16	1	Smoke Stack Gasket
17	1	Grease Bucket
18	1	Screwdriver
19	1	Hopper Burner Lid
20	1	Hopper Lid Handle
21	1	Hopper Guard
22	1	Digital Control
23	1	Hopper Assembly
24	1	Hopper Bottom Cover
25	1	Auger Drive Motor
26	1	Auger Tube Bushing
27	1	Power Cord
28	1	Thick Gasket
29	1	Power Cord Collector
30	1	Auger
31	1	Hot Rod (Ignitor)
32	1	Firepot Assembly

ITEM	QTY	DESCRIPTION
33	1	Burner Box Assembly
34	1	Hopper Burner Gasket
35	1	Hopper Burner Assembly
36	1	Fan
37	2	Bottom Pivot
38	1	Left Door
39	1	Left Door Upper Pivot
40	1	Left Plate
41	1	Magnet Block
42	1	Beam
43	4	Magnet
44	1	Back Board
45	1	Right Plate
46	1	Right Door
47	2	Door Handle
48	2	Wheels (without brake)
49	2	Wheels (with brake)
50	1	Platform
51	2	Cap Nuts
52	19	Bolt
53	8	Hexagon Bolt
54	8	Gasket
55	2	Hexagon Nut
56	1	Right Door Pivot
57	2	Gasket
58	2	Bolt
59	2	Wrench
60	4	Bolt
61	1	Hopper Assembly I
62	1	Hopper Assembly II
63	4	Keyp Nut

Remark: 52*(Screw package) has 19 screws in total, including 18 necessary screw and 1 spare screw.

ASSEMBLY INSTRUCTIONS

PARTS DIAGRAM

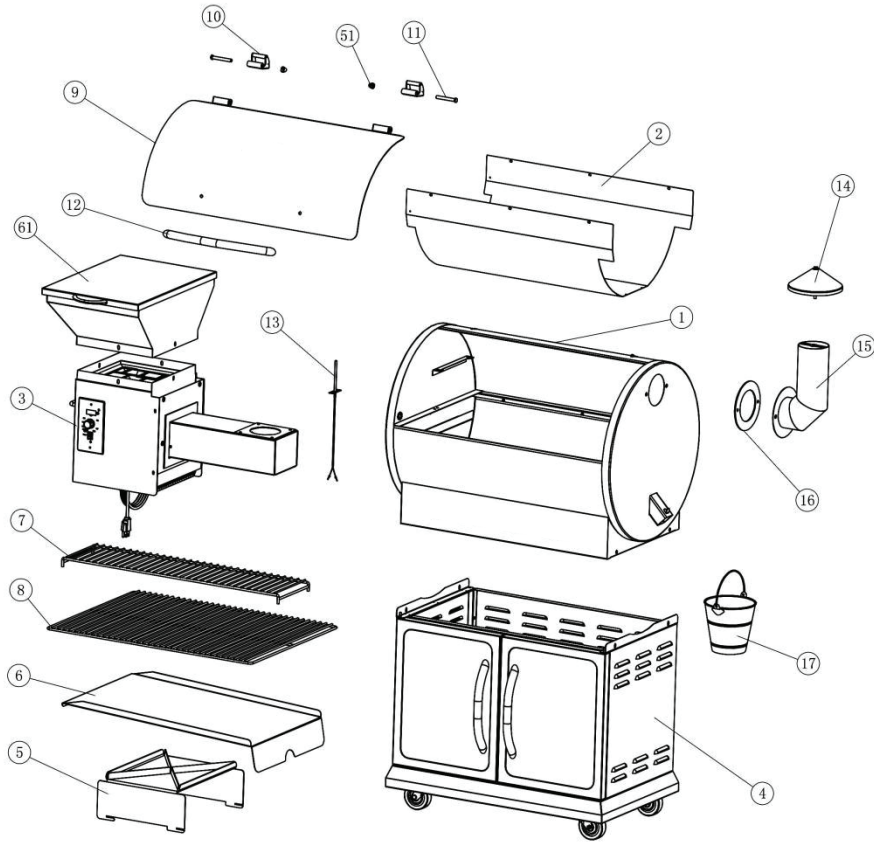

Hopper Burner Assembly:

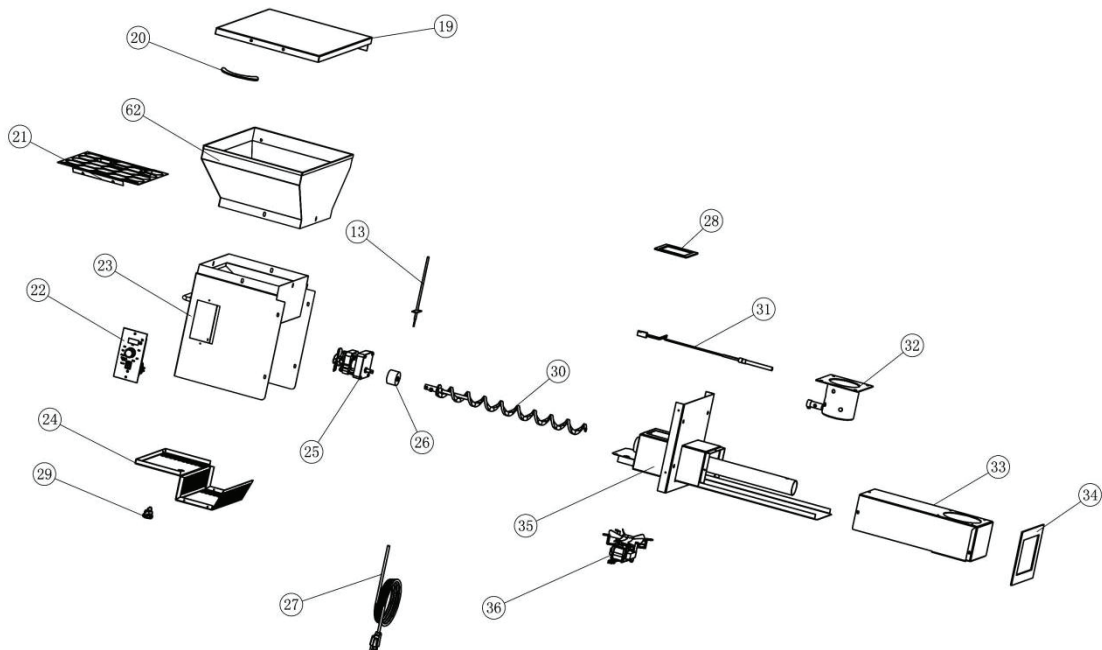

Body Frame Assembly:

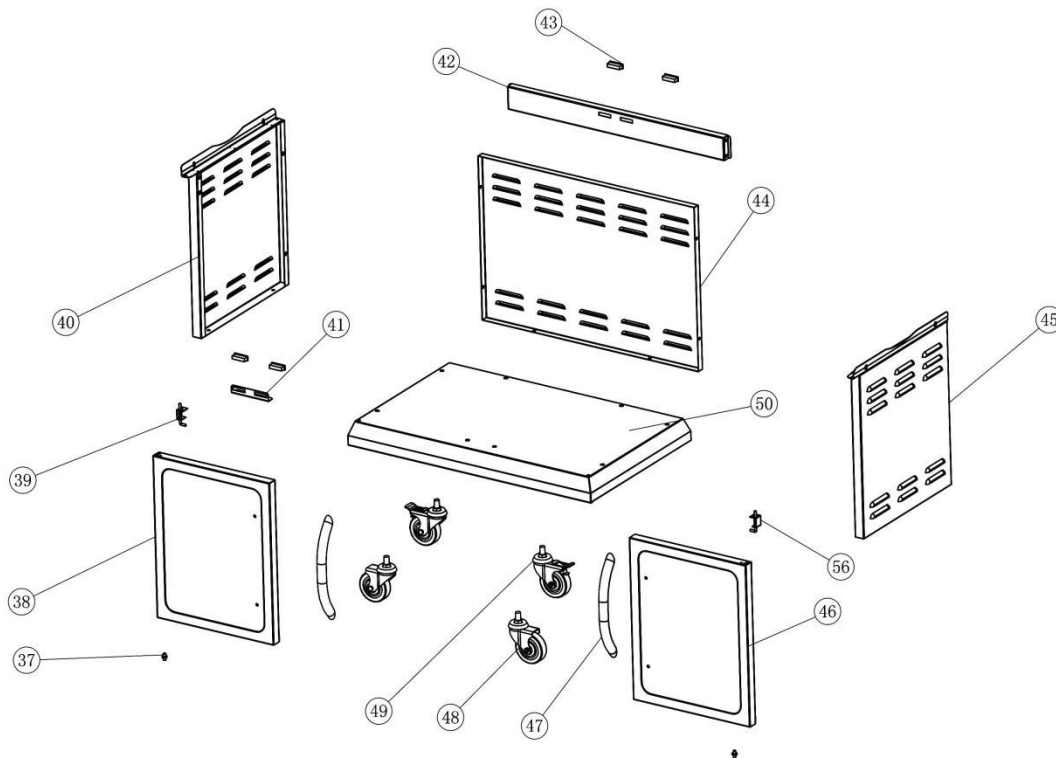

1.ASSEMBLING OF BOTTOM BASE

- 1.Turn the Platform (50) upside down. Install the wheels (without brake)(48) in the screw holes. Tighten with wrench (59). Note: The 2 wheels (without brake)(48) should be installed on the closed end of the platform.
- 2.Install the wheel (with brake)(49) into the screw holes. Tighten with wrench (59). Note: The 2 wheel (with brake)(49) should be installed on the open end of the platform.

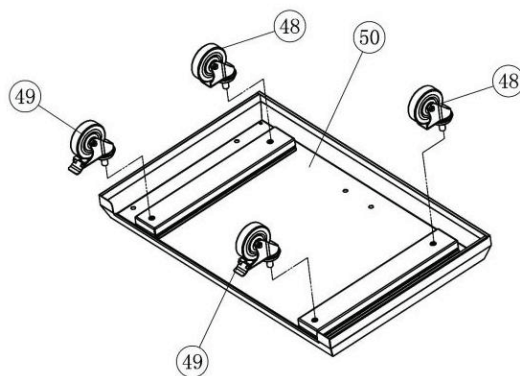

2.MOUNTING THE BODY FRAME

1. Secure Left Plate (40) on the Platform (50) with Bolt (52).
2. Secure Right Plate (45) on the Platform (50) with Bolt (52).
3. Secure Back Plate (44) on the Platform (50) with Bolt (52) and connect to Left Plate (40) and Right Plate (45).
4. Attach the Beam (42) between Left Plate (40) and Right Plate (45) with Bolt (52).

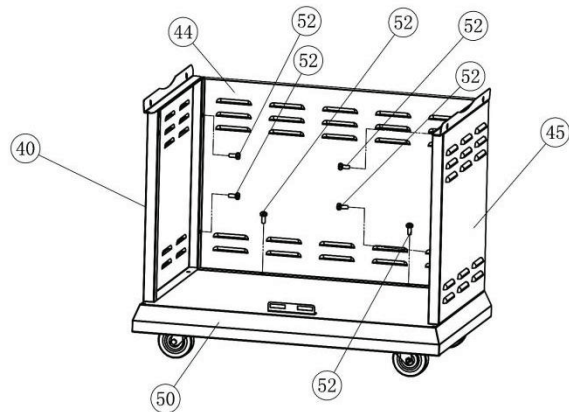
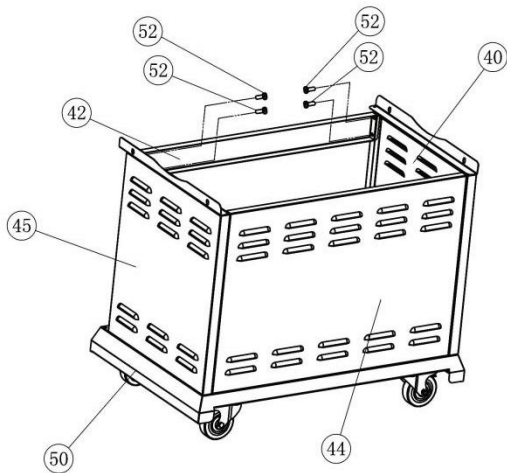
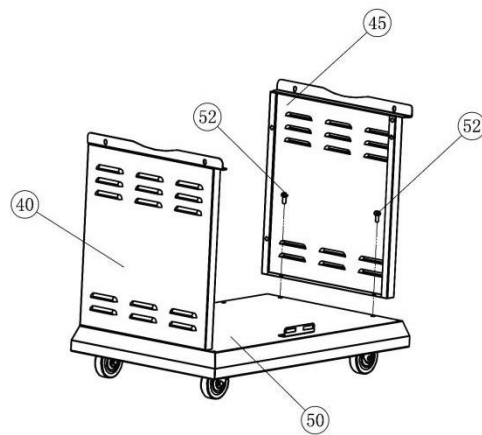
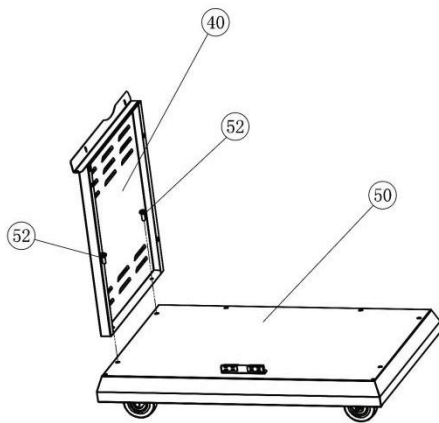

3.ASSEMBLING OF HOPPER

Insert Hopper Top Assembly I (61) into Hopper Bottom Assembly (3), align the holes. Make sure hopper opens to the front (control side). Insert the Bolts (60) through the holes in the Hopper and Kep Nuts (63), then open the Hopper Lid and tighten it from inside. The four sides are installed in the same way.

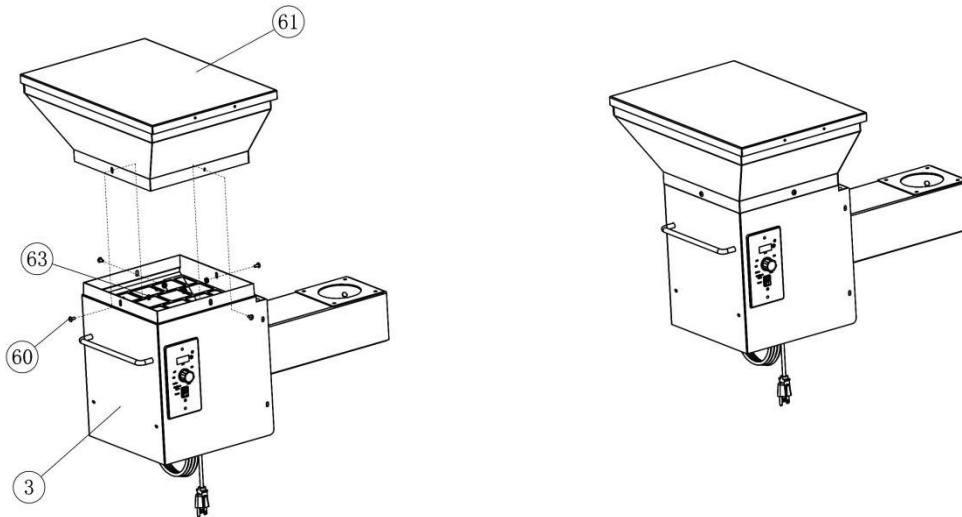

4.POSITIONING THE CHAMBER ON THE BODY FRAME

Lift up the Chamber (1) on the Body Frame (4). Make sure that the Chamber (1) is inside the left and right plate of the Frame (4). Align the Chamber holes with the plate holes and secure with Bolt (52).

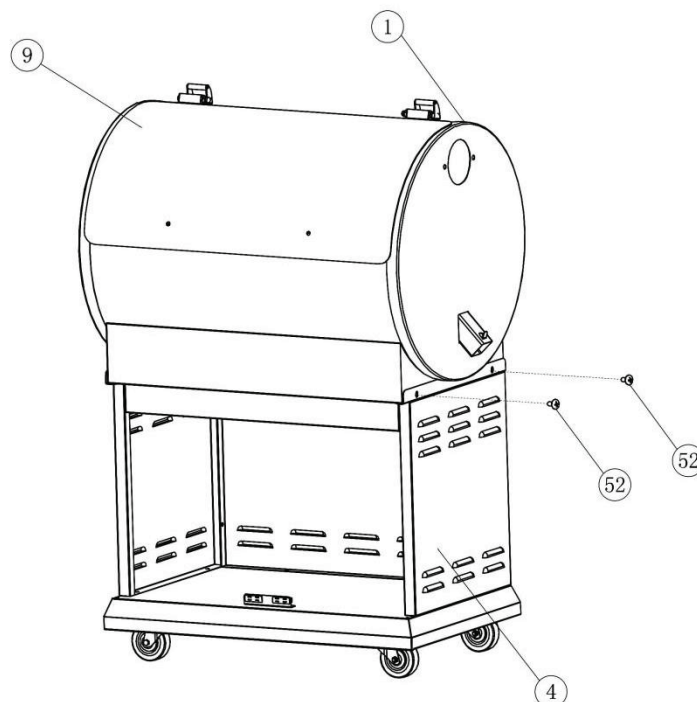

5.MOUNTING THE HOPPER TO THE CHAMBER

- 1.Remove the 4 Gaskets and Bolts from the Hopper, open the Lid, insert the Hopper into the Chamber, then using these Bolts and Gaskets install it in sequence from inside.
2. Locate the RTD plug-in connector coming from the mounted RTD inside the grill frame. Connect this with the mating connector located on the outside of the hopper burner assembly. NOTE: excess wire on the RTD plug should remain outside the Chamber.

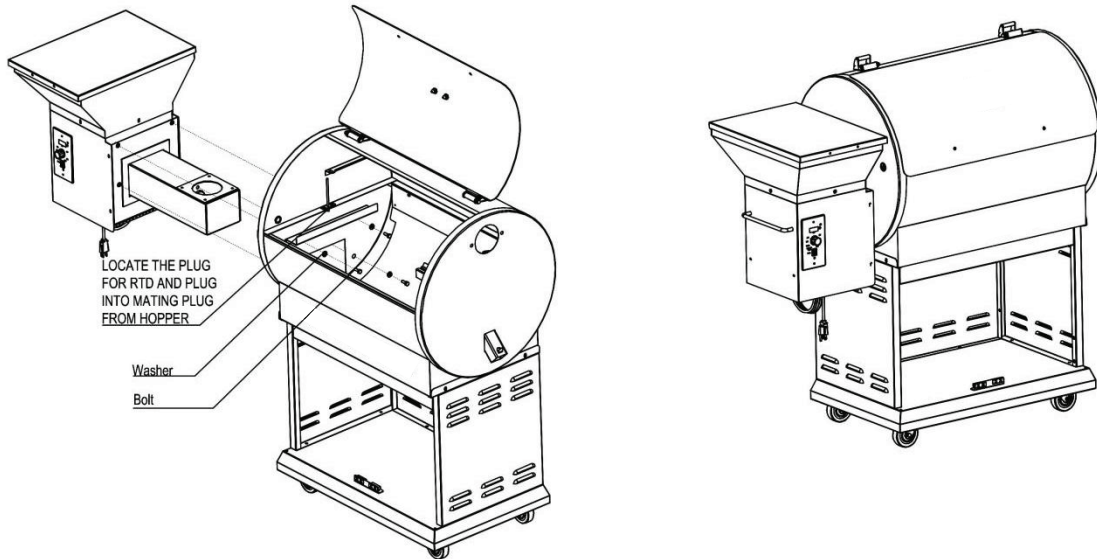

6.ATTACHING THE HOPPER BURNER LID DOOR HANDLE

Keep the Hopper Burner Lid (19) open. Insert the Bolt (58) into Gasket (57) and the hole on the Hopper Burner Lid (19) from inside. Mount Door Handle (20) from the outside and tighten the Bolts (58) with screwdriver (64).

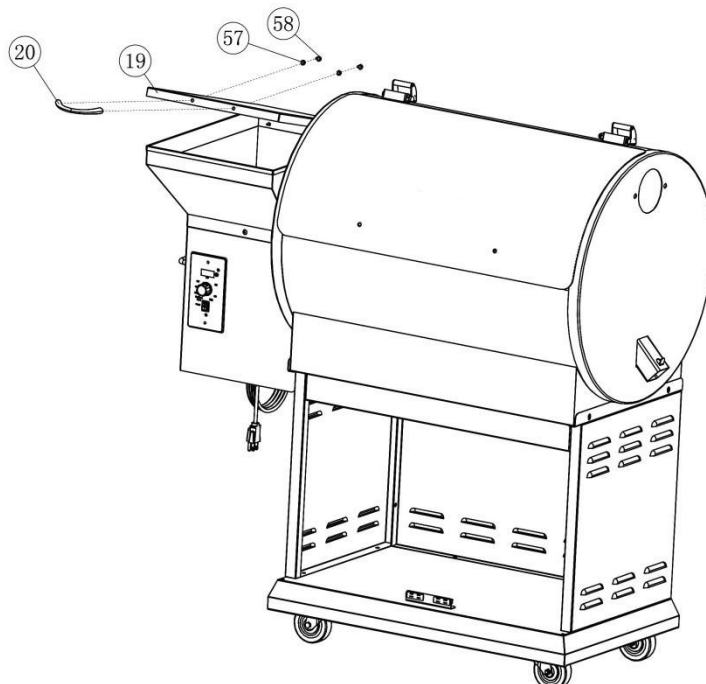

7. ATTACHING THE CHAMBER DOOR HANDLE

Insert Hexagon Bolt (53) through Gasket (54) and Lid (9) directly to the handle and tighten up. Do not over-tight.

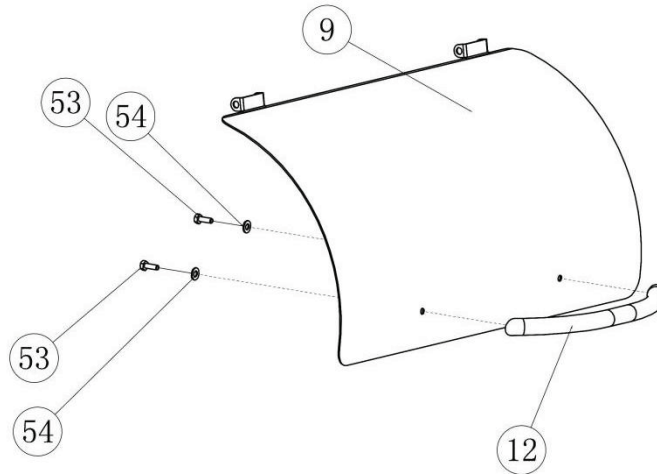

8. ATTACHING THE SMOKE STACK AND CHIMNEY CAP

1. Align the holes in the Smoke Stack (15) with holes in the Smoke Stack Gasket (16), which fits between right end of the Grill and the Smoke Stack (15). Insert the Hexagon Bolts (53) through the holes in the Smoke Stack (15) and the Smoke Stack Gasket (16).
2. Place a Gasket (54) on each Bolt and secure with Hexagon Nut (55).

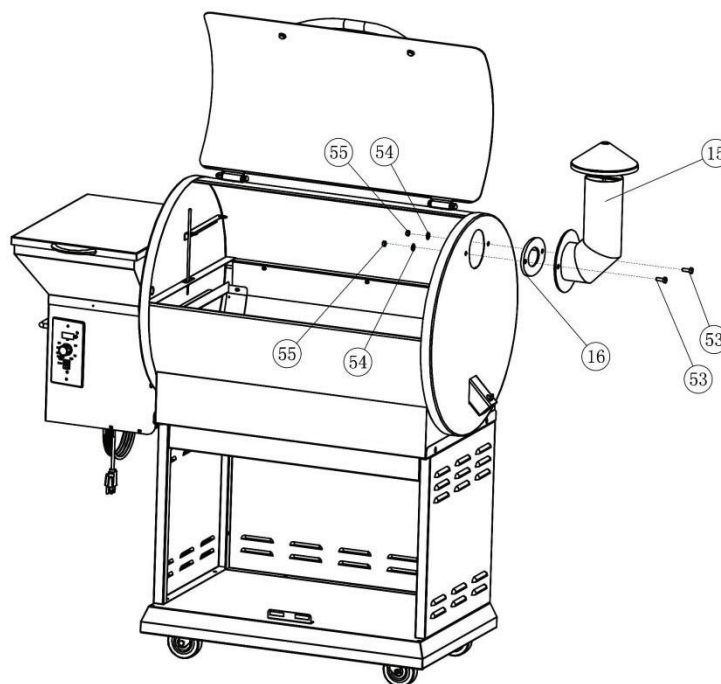

9.POSITIONING THE DOOR HANDLE

Align the holes in the Left Door (38) with the holes in the Handle (47). Place a Gasket (54) on each Hexagon Bolt (53).Align Door Handle (47) with bolts and tighten with Wrench. Repeat the former step to assemble the Right Door (46).

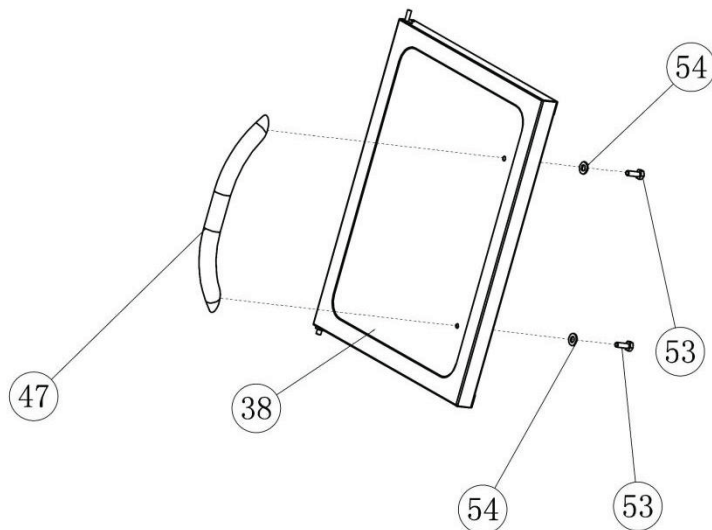

10.POSITIONING THE DOOR

1.Take the Right Door (46) with handle assembled. First insert the Bottom Pivot (37) into the small hole on Platform (50).Then pull down the Right Door Upper Pivot (56) until the upper end is aligned with top edge of the door. Then align the Right Door Upper Pivot (56) with the upper hole and pull up the pivot to secure the door.

2.Repeat Step 1 to secure the Left Door (38). Make a proper adjustment until the doors can be firmly closed.

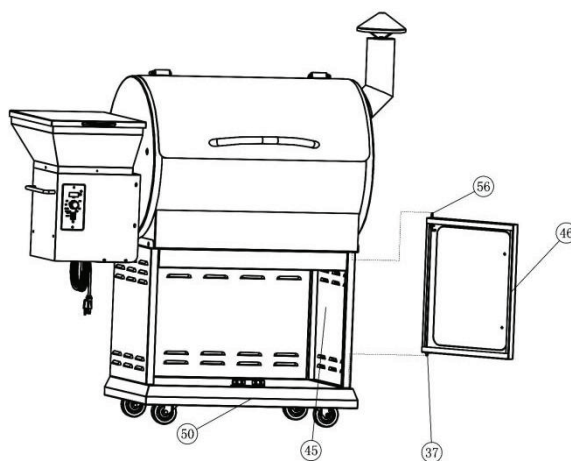

11.POSITIONING THE HEAT Baffle

Position The Heat Baffle (5) on the locating brackets which is on the inside walls of the Grill. The notched legs should be facing downward. Slide Heat Baffle (5) to the right to lock in place.

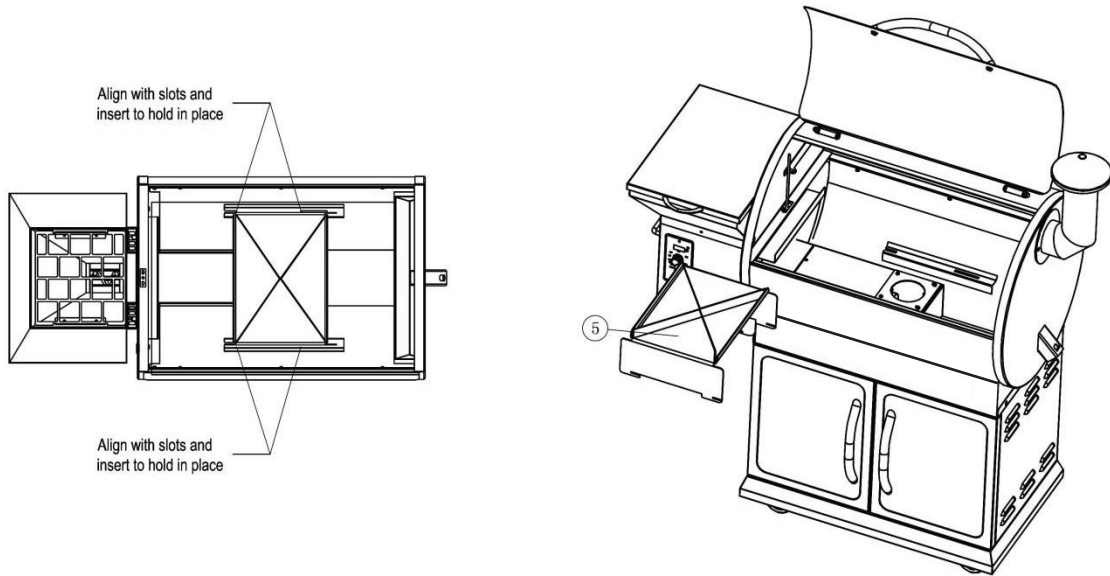

12.POSITIONING THE GREASE DRAIN PAN

Position The Grease Drain Pan (6) over the Firepot (32) by fitting over the bracket on the left side of grill wall. The notched leg of the Grease Drain Pan should be facing downward directly over the hole to the Grease Basket to fit onto the locating brackets so that the grease can flow into the Grease Drain Tube (65). If installed correctly the Grease Drain Pan should be lower on the right side to allow the grease to drain into the Grease Drain Tube.

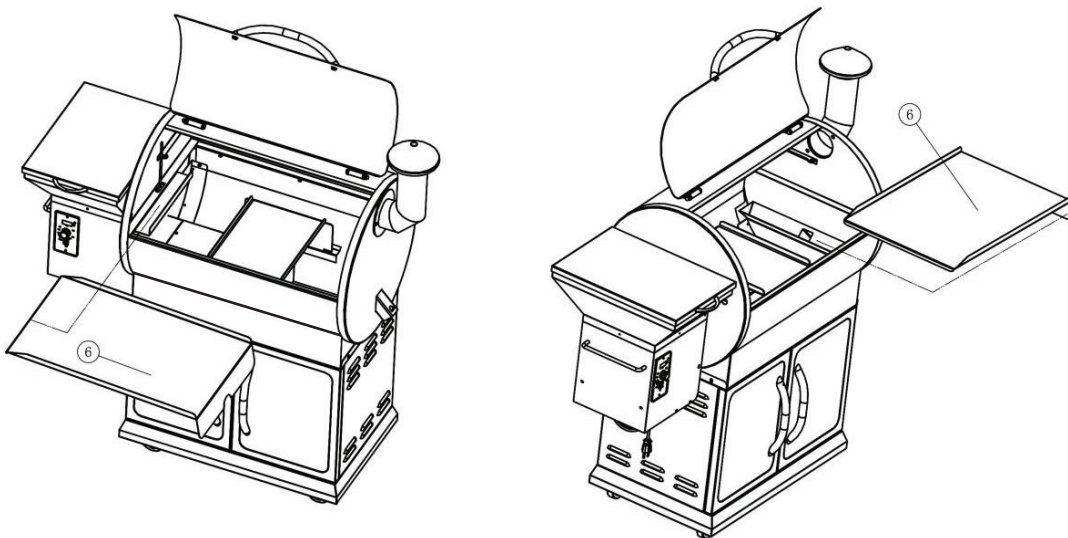

13.POSITIONING THE PORCELAIN GRILL

Position the Porcelain Grill (8) inside the chamber. Install the Warming Rack (7) on the rack supports inside the chamber.

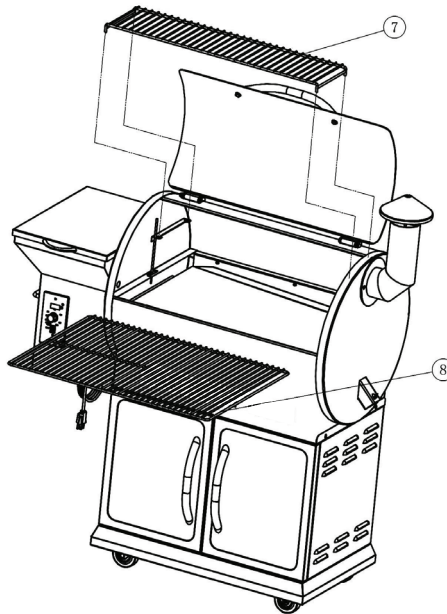

14.HANG ON THE GREASE BASKET

Locate the Grease Drain Tube which is on the right side of the chamber, then hang the Grease Bucket (17) on the hook.

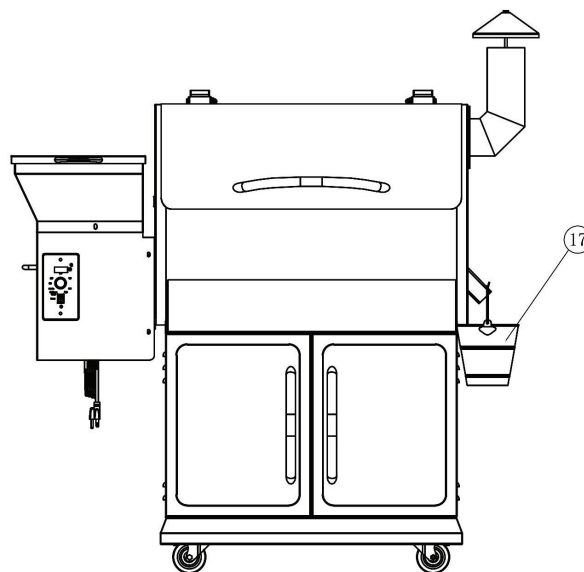

INITIAL FIRING INSTRUCTIONS

Please read this manual carefully and follow it step by step before starting your grill for the first time and each time the grill runs out of pellets.

1. Remove the Porcelain Grills, Grease Drain Pan and Heat Baffle from the interior of the grill.
2. Open the Pellet Hopper Lid, make sure there are no foreign objects in the Auger and Hopper.
3. With the Switch in the OFF(O) position, plug the power cord into a 110 Volt AC grounded outlet.
4. Turn on your grill and turn the Temperature Dial to the SMOKE position. Please check the following things:

(WARNING: Please do not touch it!)

- Confirm the Auger is turning.
- Hold your fingers above the Firepot to confirm the fan is blowing air through the Firepot.
- The hotrod will heat up and you should be able to sense the heat coming from it. (It takes approximately 1-2 minutes.)
- **You should see a temperature number displayed on your LED DISPLAY. If you see something different displayed it is an ERROR CODE. NOTE: PLEASE SEE TROUBLESHOOTING FOR DETAILS ON ERROR CODES.**

5. Turn the Temperature Dial to SHUT DOWN CYCLE.

(Please note the draft fan will stay on for 10 minutes in this mode.)

6. Fill the Pellet Hopper with Pellets. Then turn the Temperature Dial to HIGH. It takes some time for the Pellets to travel through the tube, when the Pellets start to drop, turn the Temperature Dial to SHUT DOWN CYCLE. Leave grill until it shuts off automatically.
7. Turn the Temperature Dial to SMOKE. Allow the Pellets to come to full flame. Once flames are coming out of the Firepot, turn the Temperature Dial to SHUT DOWN CYCLE and let the grill cool down.

[We suggest that you should wrap the Grease Drain Pan with heavy-duty aluminum foil before using because it is easy to clean.]

8. Place components back in place. Open the lid and turn the Temperature Dial to SMOKE. A few minutes later, when you see whitish-gray smoke coming out of the grill, close the lid and turn the Temperature Dial to any cooking setting desired.
9. Set Temperature Dial to HIGH and let grill run for 45 minutes at this setting to rid it of any foreign matter. This step must be done before cooking any food.
10. Please preheat the grill for 10 minutes before adding food. This makes your grill heat up faster and quickly reach your desired cooking temperature. Adding food sooner will slow down the heating process.

ALWAYS START THE GRILL ON SMOKE SETTING WITH THE LID OPEN !

After the Pellets are ignited, you can turn the Temperature Dial to any cooking temperature desired.

SUBSEQUENT START-UP

ATTENTION: If the grill fails to light or the fire in the Firepot goes out while cooking, it is vital to follow these steps when sufficient pellets are still in the Pellet Hopper. Failure to follow the steps may cause a hazardous “over-firing” of your grill due to an excess of unburned pellets in the Firepot.

1. Turn OFF the appliance and unplug the Power Cord. After the grill cools down, remove all food, the Porcelain Grills, Grease Drain Pan and the Heat Baffle.
2. Remove all unburned pellets and ash from inside and around the Firepot (See instruction for proper handling and disposal of ash).
3. Plug the Power Cord and turn on the grill. Pellets should fall into the Firepot and the Hot Rod should begin to heat (it will start to turn red).
4. If this step is successful, you will see flames come out of the Firepot.

Then turn off the grill and let it cool down. Next, put components back in place, open the lid and turn the Temperature Dial to SMOKE. Wait a few minutes until you see whitish-gray smoke coming out of the grill, then close the lid and turn the Temperature Dial to any cooking setting desired.

5. If this step is not successful, see TROUBLESHOOTING or contact Support to help diagnose the problem.

SHUTDOWN CYCLE

- Auger turns off
- Fan continues to run for 10 minutes

After you have finished cooking, turn the Temperature Dial to Shutdown Cycle position. The function of this setting is to leave the Draft Induction Fan running for 10 minutes to burn redundant pellets in the firepot. After the fan runs for 10 minutes, the fan will stop and the controller will power off.

CAUTION: The main power switch will shut the power off to the controller and the Temperature Dial Knob switch will cut off power to the grill components only. When servicing the controller or any parts ensure that the power supply is disconnected by unplugging the grill to avoid a shock hazard.

OPERATING TIPS

1. Like all grills, the actual temperature of this grill and the cooking times will be affected by external temperature, humidity, wind conditions, quality of pellets, etc.
2. It is beneficial to shelter your grill from the wind. This will aid in temperature output, heat retention and heat recovery time when the lid is open.
3. Do not open the lid frequently, it will increase your cooking time. You can open the lid when you want the grill to cool down quickly.
4. Please preheat the grill for 10 minutes before adding food. This will allow your grill to heat up quickly and return to your desired temperature once food is added.
5. Never move your grill while in use.
6. Never put water into the Pellet Hopper or Firepot.
7. **WARNING: NEVER ADD PELLETS TO THE FIREPOT DIRECTLY. IT IS DANGEROUS.** If you run out of pellets and lose your fire while cooking, let the grill cool down and start again with the INITIAL FIRING INSTRUCTIONS.
8. We recommend you cover your Grease Drain Pan with heavy-duty aluminum foil and change it frequently. This is the simplest way to maintain your Grease Drain Pan. Failure to clean the Grease Drain Pan, V-shaped Grease Drain and Grease Drain Tube may cause grease fires. If this situation happens, turn the Switch OFF(O) to reduce the amount of oxygen in the Chamber and keep the lid open until the fire is completely out. **AT THE SAME TIME, BE CAREFUL NOT TO BURN YOURSELF.** When the grill is completely cool, clean any grease accumulation from the V-shaped Grease Drain and the Grease Drain Pan. Replace the foil on the Grease Drain Pan. Then restart the grill and resume cooking.

MAINTENANCE & CLEANING

Your GRILL requires regular maintenance.

Make sure your grill is OFF, unplugged and completely cold before performing any maintenance and cleaning.

Grease

1. With regular use your grill will accumulate grease on the Flue Lining, the Grease Drain Tube, the V-shaped Grease Drain and the Grease Drain Pan. Always be sure these areas are clean and free of grease and debris. You should check and clean these areas regularly to reduce the risk of fire.

2. It is easier to remove accumulated grease when the grill is still warm (not hot).

BE CAREFUL NOT TO BURN YOURSELF. Heat-resistant gloves are recommended.

If too much grease is allowed to build up in the V-shaped Grease Drain or is allowed to plug the Grease Drain Tube, a grease fire could result. It is necessary to clean these areas regularly. You can scarp the grease accumulation from inside the V-shaped Grease Drain and Grease Drain Tube by using a stiff, nonmetallic tool. Much of the loosened grease can be pushed down through the Grease Drain Tube and fall into the Grease Bucket. Wipe up remaining grease residue with paper towels or disposable rags.

Flue Pipe(Smoke Stack)

Remove the Chimney Cap Assembly, clean it with warm soapy water. Scrape the creosote and grease accumulation from inside of the vertical and horizontal sections of the Flue Pipe by using a stiff, nonmetallic tool such as a wooden paint stir stick. Once the creosote and grease residue has been loosened from the Flue Pipe Lining, much of it can be cleaned with paper towels or disposable rags. Do not spray water or other liquid cleaners onto the inside of the grill.

Outside surfaces

1. Use warm soapy water to wipe away grease. Do not use oven cleaner, abrasive cleansers or abrasive cleaning pads on the outside grill surfaces.

2. It is highly recommended that you use a Cuisinart Grill Cover to protect your grill .

3. You can use a high-quality car wax on the outside surfaces of your grill to protect it's finish.

Internal component

1. To clean the Porcelain-coated Grill Grates we recommend using a long-handled cleaning brush designed for Porcelain-coated Grates.

2. It is recommended that you clean your Grill Grates after each use.

3. Clean the inner RTD temperature probe after each use.

Ash

Clean the ash from the interior of the grill periodically. If excessive ash is in the firepot, it may cause the fire to go out. This is especially true in the SMOKE setting. A Cuisinart Ash Vacuum is an excellent tool to use for removing the ash. **WARNING: MAKE SURE THE GRILL FIRE IS OUT, THE UNIT IS OFF, UNPLUGGED AND COLD BEFORE ATTEMPTING TO CLEAN ASH FROM THE GRILL.**

TROUBLESHOOTING

CAUTION: Make sure the grill is completely cool and unplugged before you do any inspection, cleaning, maintenance or service work.

Problem	Potential Cause	Solution
Grill does not work properly	Power	Make sure the power cord is plugged in. Verify there is power at the electrical outlet.
	Fuse	Remove the digital control, check the fuse on the back. Replace the fuse if blown.
	Hot Rod	If both of the Draft Inducer Fan and the Auger Driver Motor are operating, the Hot Rod needs to be replaced. If one or both are not operating, please contact customer support.
	Wires & Connections	Check the wires and connectors to make sure they are fastened securely and not damaged. Contact customer support if you need help.
	Auger Drive Motor	Locate the small fan motor blade on the back of the auger drive motor. Turn unit on. If the fan does not turn on then the Auger Drive Motor needs to be replaced.
Fire goes out	Too much ash	Clean the ash. Refer to MAINTENANCE & CLEANING.
How to start	SMOKE setting	Start your grill on the SMOKE setting with the lid open. After 2 minutes, close the lid and turn to any temperature setting desired.

Unexpected grill temperature is displayed	External Factor	Grill temperature is influenced by environmental factors such as high temperature, wind and direct sun. Place unit in shaded area. Open the lid to reduce inside temperature.
Excess or discolored smoke	Pellets	Replace moist pellets with fresh dry pellets.
Get your new parts	Contact Customer Service	When contacting customer support please have the following information available: Your name, phone number, address, your grill serial number and part identification number. Your part number is listed on the COMPONENT LIST.

ERROR CODES

LEr (Low Temperature Alarm)

- Grill temperature was below 150°F for more than 20 minutes.

HEr (High Temperature Alarm)

- Grill temperature reached 550°F.

Er 1

- Ensure temperature probe is properly connected to the controller board.

Er 2

- Temperature probe short circuit.

If this error occurs at initial start up, turn grill off, turn dial to Power Shut Down and then back to Smoke. Turn grill back on to begin lighting process. Whenever either of these alarm conditions occurs you should check to see what caused this condition and fix the problem.

WARNING: DO NOT TURN OFF THE SWITCH WHILE THE FAN IS STILL WORKING ON THE SHUT DOWN CYCLE, THE GRILL WILL AUTOMATICALLY SHUT OFF WHEN THE CYCLE IS DONE. INTERRUPTION OF THE SHUT DOWN CYCLE COULD RESULT IN A FIRE IN THE HOPPER CHAMBER.

DIGITAL THERMOSTAT CONTROL WIRING DIAGRAM

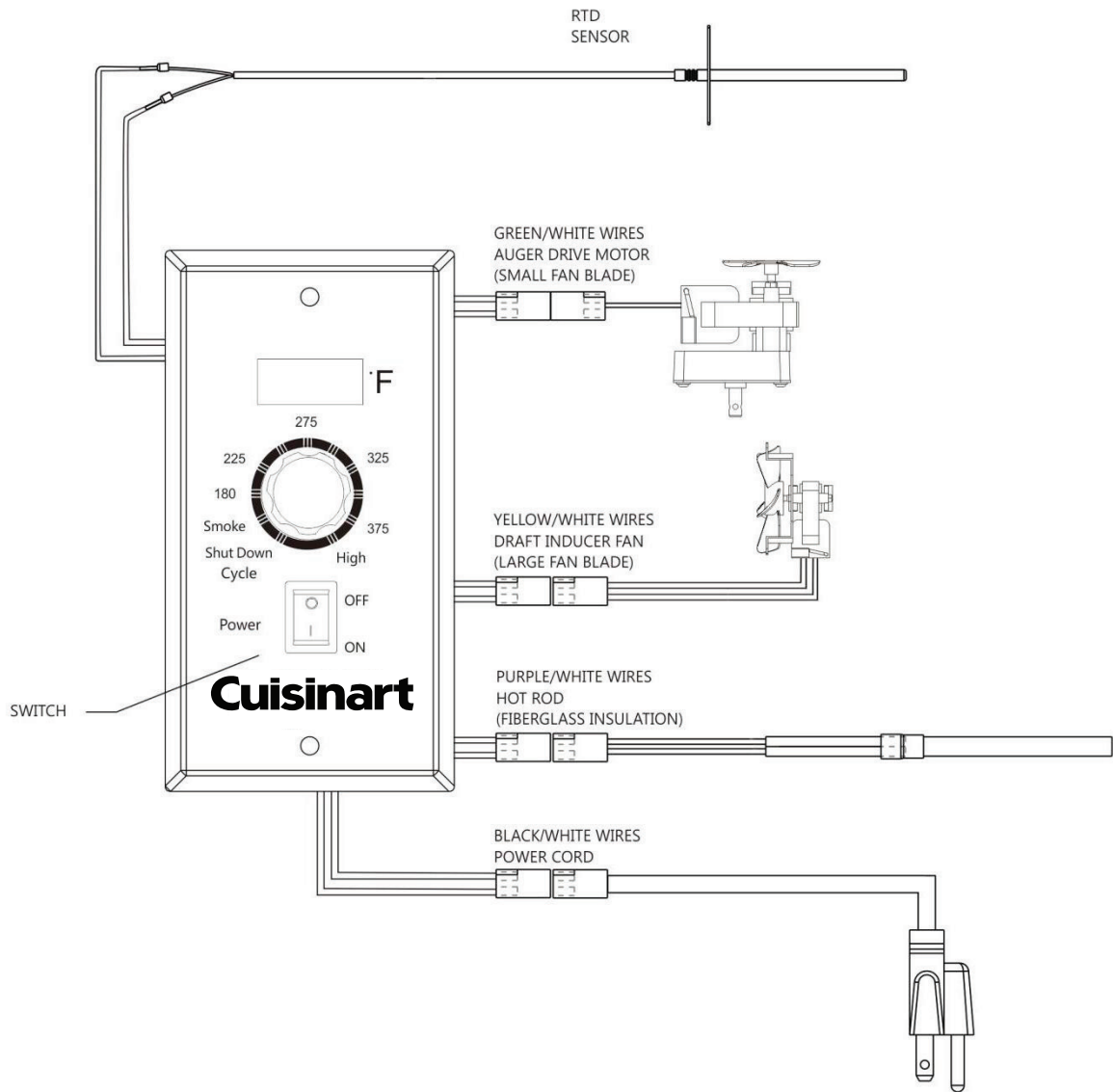

SUPPORT

Thank you for purchasing a Cuisinart grill!

If you have any question, please contact customer support.

When calling customer please be prepared to provide the following information:

- 1.Dealer's name and date of purchase
- 2.Purchaser's name, phone number and address
- 3.Model number, serial number and part identification numbers
- 4.Please be prepared to describe your problem accurately so we can help you resolve your issue
- 5.Providing pictures or videos is beneficial

MON TO FRI, 9:00 A.M. - 5:00 P.M. EASTERN STANDARD TIME

SERVICE CONTACT: 1-866-994-6390

EMAIL: grilling@thefulhamgroup.com

Cuisinart

1 YEAR LIMITED WARRANTY

PROOF OF PURCHASE is required to access this warranty program, which is in effect from the date of purchase. Customers will be subject to parts, shipping, and handling fees if unable to provide proof of the purchase or after the warranty has expired.

If you have any questions or problems, you can call our customer service department at 1-866-994-6390 from 9:00am to 5:00pm Eastern time, Monday through Friday for assistance.

LIMITED WARRANTY

Manufacturer warrants this product for 1 year on all parts from the date of purchase.

WARRANTY PROVISIONS

This warranty is non-transferable and does not cover failures due to misuse of improper installation or maintenance.

This warranty is for replacement of defective parts only. We are not responsible for incidental or consequential damages or labor costs.

This warranty does not cover corrosion or discoloration after the grill is used, or lack of maintenance, hostile environment, accidents, alterations, abuse or neglect.

This warranty does not cover damage caused by heat, abrasive and chemical cleaners, or any damage to other components used in the installation or operation of the grill.

Paint is not warranted and may require touch-up. Some states do not allow the limitation or exclusion of incidental or consequential damages, so the above limitations or exclusions may not apply to you. This warranty gives you specific legal rights, and you may also have other rights that vary from state to state.

For replacement parts, call our customer service department at 1-866-994-6390 from 9:00am to 5:00pm Eastern time, Monday through Friday for assistance.