

# MODEL 94NC NON-CATALYTIC UNIT

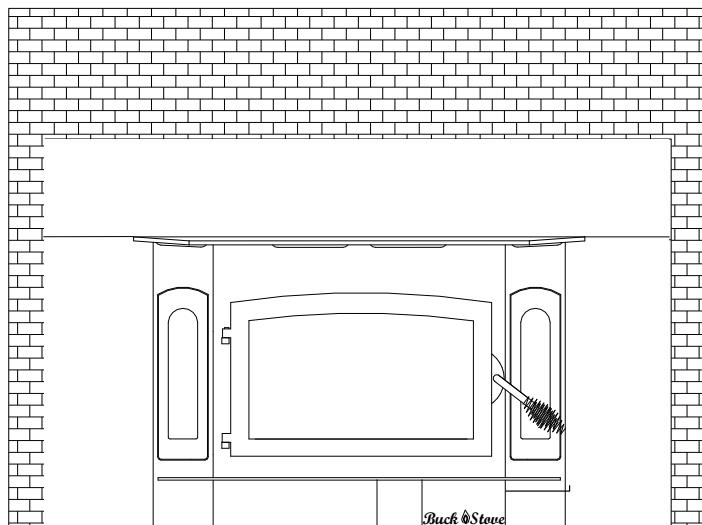

## FIREPLACE INSERT & FREESTANDING

### FEATURES

### PREPARATIONS

### INSTALLATION

### OPERATION

### MAINTENANCE

### SAFETY

## SAFETY NOTICE

**IF THIS HEATER IS NOT PROPERLY INSTALLED, A HOUSE FIRE MAY RESULT. FOR YOUR SAFETY, FOLLOW THE INSTALLATION INSTRUCTIONS. CONTACT THE AUTHORITY HAVING JURISDICTION (SUCH AS MUNICIPAL BUILDING DEPARTMENT, FIRE DEPARTMENT, FIRE PREVENTION BUREAU, etc.) CONSULT BEFORE INSTALLATION TO DETERMINE THE NEED TO OBTAIN A PERMIT. KEEP THESE INSTRUCTIONS FOR FUTURE USE.**

TESTED AND LISTED BY:



ITS/WARNOCK HERSEY, MIDDLETON, WI

**MANUFACTURED BY NEW BUCK CORPORATION**

**200 ETHAN ALLEN DRIVE**

**P.O. BOX 69**

**SPRUCE PINE, N.C. 28777**

[www.buckstove.com](http://www.buckstove.com)

Revised January 2013

# TABLE OF CONTENTS

Important Instructions .....	2
SECTION I: Introduction .....	3
Type of wood and loading procedures .....	3
Parts List.....	4
SECTION II: Masonry Insert Installation .....	5
Installation Preparation-Fireplace.....	6
Mounting Trim Panels.....	7
SECTION III: Residential Freestanding Installation .....	11
Floor Protection.....	12
Installing thimble through combustible wall .....	14
Final Check .....	18
Clearances: Residential / Single Wall Pipe .....	19
SECTION IV: Wood Heater Safety .....	20
SECTION VI: Operation .....	21
Room Air Blower Operation.....	22
SECTION VII: Troubleshooting.....	23
Warranty .....	26

# INSTALLATION, OPERATION, AND MAINTENANCE INSTRUCTIONS MODEL 94NC

BEFORE INSTALLING YOUR NEW BUCK STOVE,  
READ THE ENTIRE INSTRUCTION MANUAL

## IMPORTANT INSTRUCTIONS

### WARNING

THIS UNIT GENERATES HIGH HEAT, SO TREAT IT WITH CARE. **HOT WHILE IN OPERATION**. KEEP CHILDREN, CLOTHING AND FURNITURE AWAY. CONTACT MAY CAUSE SKIN BURNS. DO NOT USE CHEMICALS OR FLUIDS TO START THE FIRE. DO NOT BURN GARBAGE OR FLAMMABLE FLUIDS. DO NOT CONNECT TO ANY DISTRIBUTION DUCT OR SYSTEM. READ ALL INSTRUCTIONS BEFORE INSTALLING AND USING THE APPLIANCE. FAILURE TO FOLLOW INSTRUCTIONS MAY RESULT IN PROPERTY DAMAGE, BODILY INJURY OR EVEN DEATH. AVE THESE INSTRUCTIONS FOR FUTURE REFERENCES.

- The New Buck Corp. non-catalytic Model 94NC has been tested and listed by ITS, (Warnock Hersey) to ANSI/UL Standards, :UL1482(2000) :UL1482(2006) :UL1482 (2010) Standard for Room Heaters, Solid Fuel Type.
- Install and operate your unit according to instructions provided in this manual. Local building codes may apply; therefore, contact your local building inspector or fire marshal for necessary installation requirements and permits which may go beyond these instructions. Contact your insurance company for coverage and installation inspection.
- **DO NOT INSTALL IN SLEEPING ROOMS.**
- **NOTE: When burning any unit or appliance that combusts fuel for heat, such as coal, oil, wood or natural and (L.P.) liquid petroleum gas, we highly recommend the use of smoke and carbon monoxide detectors in your home.**
- Examine the masonry fireplace and chimney prior to installation of fireplace accessory to determine that construction meets the minimum fireplace construction requirements illustrated in the instructions. Make sure that it is free from cracks, loose mortar, creosote deposits and other blockage, or other signs of deterioration.

### CAUTION

DO NOT USE MORE THAN ONE STOVE PER CHIMNEY. DO NOT USE A FLUE INTENDED FOR A GAS APPLIANCE.

## CAUTION

YOUR CHIMNEY OR FLUE MUST BE CORRECTLY SIZED. A CHIMNEY OR FLUE THAT IS TOO SMALL OR LARGE IN DIAMETER OR TOO SHORT CAN CAUSE YOUR STOVE TO SPILL SMOKE WHEN THE DOOR IS OPENED.

## SECTION I

### INTRODUCTION

The MODEL 94NC is a non-catalytic unit designed to meet the most stringent emissions standards without use of a catalytic combustor. This effect is achieved through use of secondary air which is mixed with primary air in firebox.

**For peak performance, we suggest the use of natural seasoned hard wood. Load wood from front to rear.**

**NOTE: Soft woods such as pine, create more creosote, clogging of chimney and produce a less efficient burn performance.**

**You should not burn trash or garbage, artificial or paper logs, gift wrapping, treated or painted wood, or any type of coal or flammable fluids.**

The primary air, which is controlled by user, burns the wood. Secondary air is admitted into firebox through secondary air tubes at top of firebox. This secondary air burns impurities in the smoke released from initial wood burning. The temperature necessary for this combustion is maintained through firebrick refractory. If any more technical information is necessary, contact your local dealer.

Under specific test conditions this heater has been shown to deliver heat at rates ranging from approximately :

11,900 BTU/HR. on Low  
42,100 BTU/HR. on High

This unit is equipped with a standard room air blower.

## EPA COMPLIANCE STATUS

The Model 94NC heater meets U.S. Environmental Protection Agency's Emission limits for non-cat wood heaters sold after July 1, 1992. Under specific conditions this heater has been shown to deliver heat at rates ranging from approximately 11,900 to 42,000 BTU/hr for the Model 94NC.

# MODEL 94NC WOOD STOVE

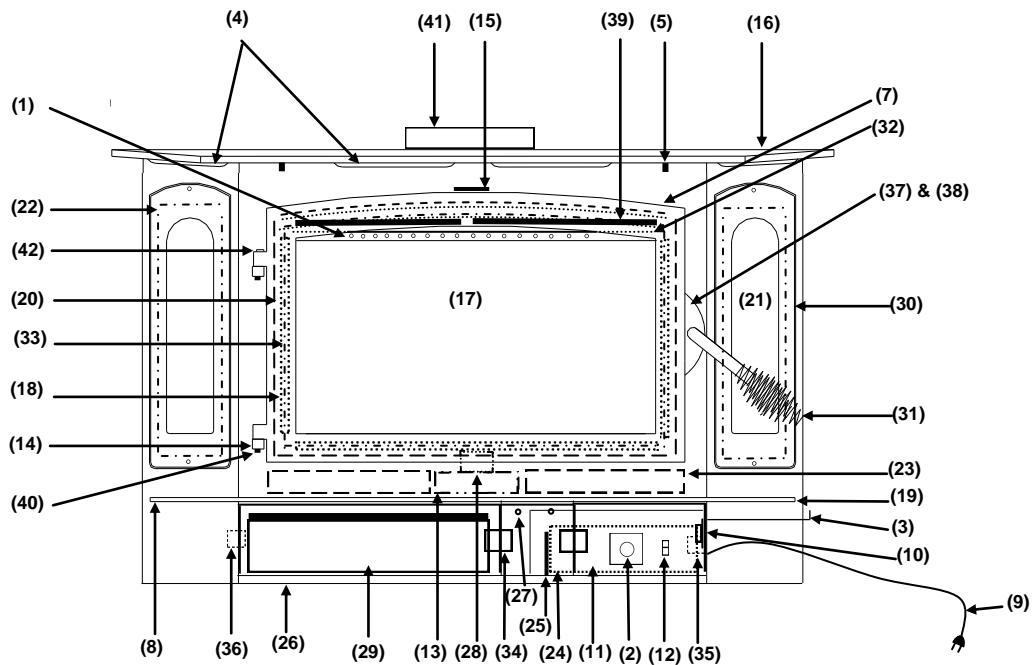

- |                                  |                         |                                 |
|----------------------------------|-------------------------|---------------------------------|
| 1. Secondary air tubes           | 15. Pipe stop           | 29. Ash pan                     |
| 2. Blower control (rheostat)     | 16. Outer top           | 30. Bay side overlay            |
| 3. Primary air control           | 17. Door glass          | 31. Door handle & spring handle |
| 4. Warm air outlets              | 18. Glass clips         | 32. Top air wash                |
| 5. Baffles (interior of stove)   | 19. Hearth              | 33. Cast door glass gasket      |
| 6. Air inlet                     | 20. Door gasket         | 34. Cover door hinge            |
| 7. Cast Door                     | 21. Side glass          | 35. Magnet holder               |
| 8. Hearth extension              | 22. Side glass gasket   | 37. Door latch                  |
| 9. Power cord                    | 23. Firebrick           | 38. Door latch screw            |
| 10. Disc thermostat              | 24. Motor               | 39. Top baffle board            |
| 11. Motor guard screen           | 25. Motor mount bracket | 40. Hinge pins                  |
| 12. Automatic/off/man. switch    | 26. Cover Door          | 41. 8" Flue exit                |
| 13. Bottom secondary air channel | 27. Cover door screws   | 42. Hinge cap                   |
| 14. Hinge Block                  | 28. Shot gun air box    |                                 |

## SECTION II

### MASONRY INSERT INSTALLATION

The Model 94NC may be installed using an all masonry fireplace built in accordance with Uniform Building Code and National Fire Protection Association (NFPA). The first step in this type of installation is to determine acceptability of the fireplace and chimney for use with a woodstove, both construction and condition of fireplace are important considerations when installing a woodstove. The chimney should extend at least 3' above roof and at least 2' above any point of roof within 10'.

### CAUTION

REMEMBER TO HAVE YOUR CHIMNEY INSPECTED FOR LEAKS AND BLOCKAGE **BEFORE** YOU INSTALL YOUR STOVE. DO NOT CONNECT THIS UNIT TO A CHIMNEY FLUE SERVING ANOTHER APPLIANCE.

### MINIMUM CLEARANCE MASONRY INSERT

#### MODEL 94NC

A. Side Wall Combustible	12"
B. Front Floor Protector	16"
C. Side Floor Protector	8"
D. Side Wood Trim	10"
E. Top Wood Trim	18"
F. Mantel or Brackets	24"

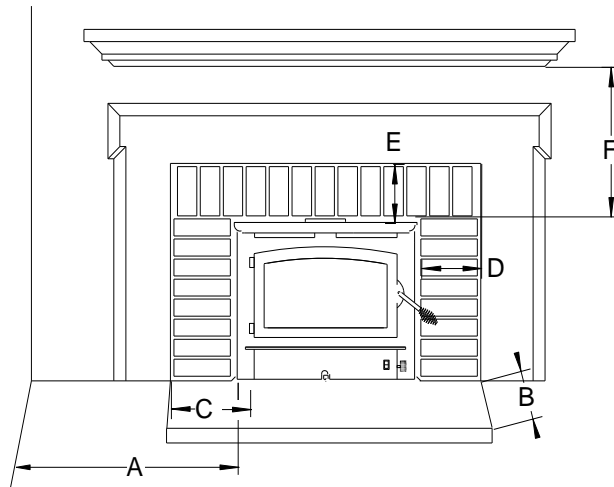

1. The hearth must be of masonry construction and must extend a minimum of 16" in front of the firebox opening and a minimum of 8" to either side of the firebox opening. Minimum floor protection under unit must have an R-value of 0.30.
2. If there is no minimum hearth protection from front of firebox opening and front of masonry hearth, a floor protector must be used in front of hearth to protect combustible materials. The floor protector must be 3/8" minimum thickness non-combustible material or equivalent.(See Page 12,13).

## POSSIBLE TOOLS NEEDED FOR INSTALLATION

If you decide to install your own stove, there are several hand tools you may need to do the job. If you do not already have them they are readily available at most hardware stores.

- Caulking gun
- Large adjustable wrench (may not be needed)
- Drop cloths or newspapers
- Vacuum cleaner or whisk broom
- Flashlight
- 1 tube of RTV silicone, Code 103 or 106, or high temperature rubber cement rated between 450° F- 600° F
- 7/32" drill bit and drill
- Socket/Ratchet Set

## INSTALLATION PREPARATION

### Fireplace:

1. Relocate furniture and other materials away from front of fireplace to allow free access to fireplace.
2. Cover hearth and adjacent floor areas with drop cloths to protect from soiling or marring surface.
3. Remove existing fireplace damper plate.
4. Thoroughly clean fireplace of ashes and soot.
5. Check chimney and smoke chamber for excessive buildup of creosote or soot. Also, check for obstructions, such as bird's nests. If chimney is excessively dirty, clean it or have someone clean it professionally BEFORE installing or using room heater.
6. If fireplace has an ash dump or outside air provision, these must be sealed off with metal or tightly packed non-combustible insulation to prevent cold air from entering fireplace chamber.

---

## MASONRY INSERT INSTALLATION INSTALLATION OPTIONS

This unit (appliance) may be installed into an all masonry fireplaces, built in accordance with Uniform Building Code and National Fire Protection Association (*NFPA 211*).

**NOTE:** *Check with local building officials for any permits required for installation of this unit and notify your insurance company before proceeding with installation*

It is imperative that your fireplace and oversize flue liner meets applicable codes. It is recommended that one of the following procedures be followed.

- A. A **Chimney Connector** can be installed from appliance flue exit through damper with an air-tight face seal. See option (A) Figure 2, page 7.
- B. A listed **Direct Connect** can be installed from appliance flue exit through damper into first section of flue liner with an air-tight seal. See option (B) Figure 3, page 7.
- C. A **Positive Connect** can be installed from appliance flue exit continuing up through entire chimney and exiting at top of the chimney. See option (C) Figure 4, page 7.

**⚠ SAFETY NOTICE**

**If this appliance is not properly installed, a house fire may result. For your safety, follow the installation directions. Contact local building or fire officials about restrictions and installation inspection requirements in your area.**

OPTION (A) Figure 2,

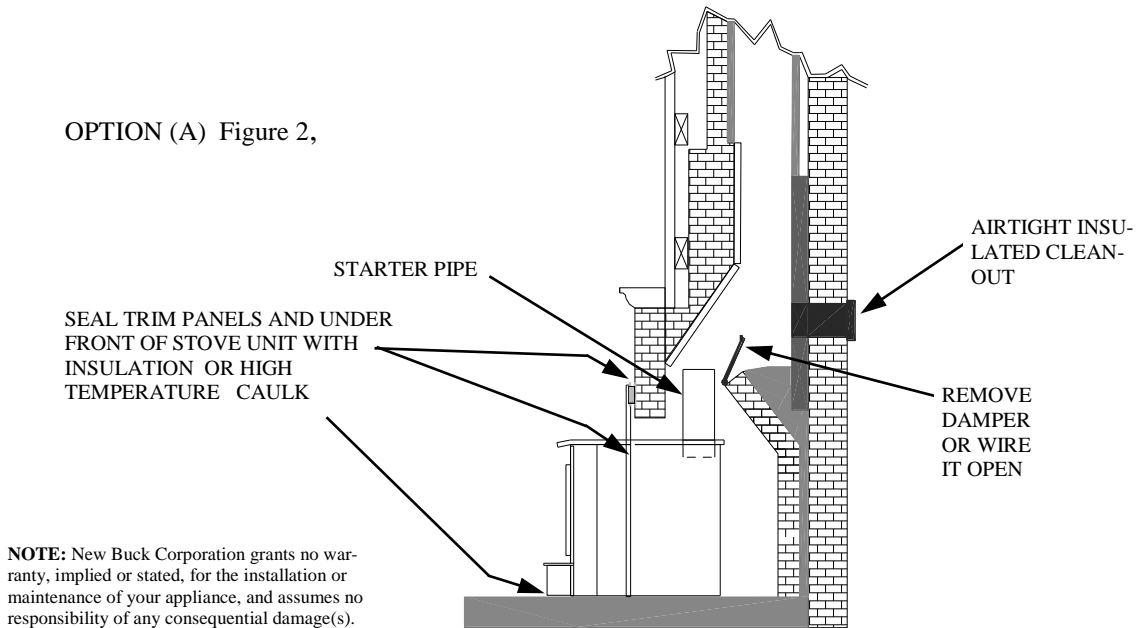

OPTION (B) Figure 3,

**NOTE:** Follow installation instruction with Direct Connection Kit. (Kit sold separately)

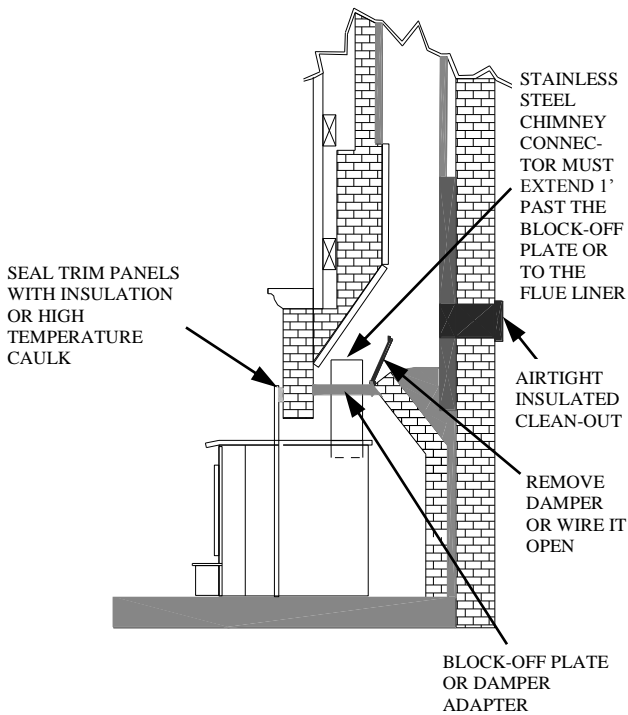

OPTION (C) Figure 4,

**NOTE:** Follow installation instruction with Positive Connection Kit. (Kit sold separately)

INSTALL A NON-COMBUSTIBLE COVER PLATE TO PREVENT WATER FROM ENTERING THE CHIMNEY

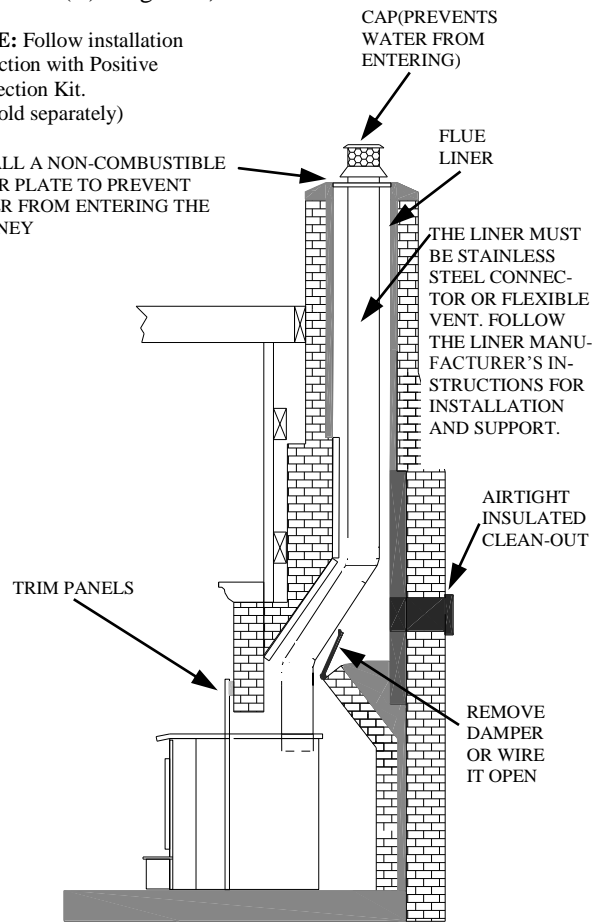

# INSTALLATION PROCEDURE

(Use a chimney connector or a Listed Direct or Positive Connect) (See Page 6).

## POSITIONING HEATER

When positioning heater, the following conditions **MUST** be met. (See Figure 5).

1. The front of flue opening must be positioned **BEHIND** rear edge of the lintel to ensure proper draft. (See Figure 5).
2. Center heater in fireplace opening.

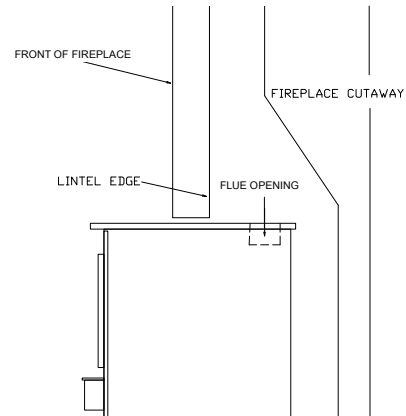

**FIGURE 5 POSITIONING**

## MOUNTING TRIM PANELS

**NOTE:** Mount top trim panel so that it sits in front of top of side trim panels.

After unit is positioned, mark mounting position of trim panels as follows:

1. Place side trim panels flat against face of fireplace. Mark down front edge of trim panel with a pencil to make a vertical reference line. (See Figure 6).
2. Set top (long) trim panel in place on top of unit. The panel should be flat against the outside face of fireplace, and standing vertically. Mark along lower edge of trim panel with a pencil to make a reference line for mounting.
3. Slide unit out of fireplace far enough to work behind trim panel reference lines.
4. Mount side trim panels. (See Figure 6).
  - a. Position trim panel on reference line.
  - b. Drill mounting holes in center of trim panel mounting brackets to allow for adjustment in and out if necessary.
  - c. Mount trim panel using self-tapping screws provided.
5. Place top panel back on reference mark. Take the top trim panel mounting bracket, position bracket so it overlaps rear lip of top trim panel. Drill mounting holes in top of stove using holes in bracket as guide. Tighten down screws.
6. Now, follow installation procedures listed. Install heater and connect kit in fireplace. If not using one of installation methods shown on (Page 7), then continue.
7. Slide unit back into fireplace. Check to be sure that trim panels are properly positioned so they lie flat against front of fireplace. If one or more of panels is out of position, slide unit out and reset by loosening the mounting screws and repositioning in the slot. Reinstall top trim panel by sliding rear lip of top trim panel underneath front lip of mounting bracket.

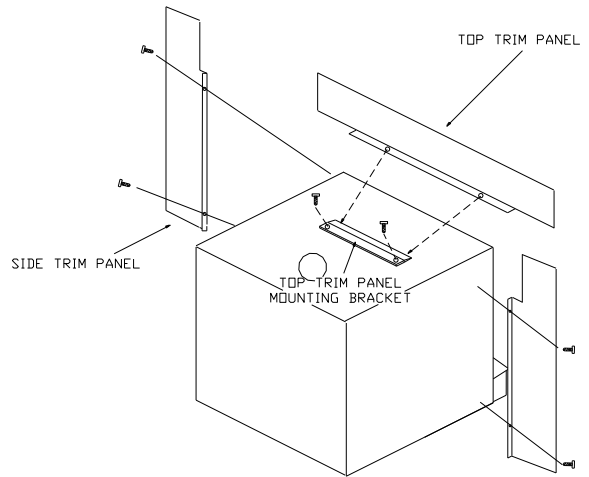

**FIGURE 6 MOUNTING TRIM PANELS**

8. Obtain outer trim kit provided with insert kit. Slip it over top and sides of trim panels.(See Figure 7). (Top ends of outer trim may need to be trimmed to fit).
9. Using insulation provided, peel and stick to back of panels. It will overlap fireplace dimensions by 1" on each side and top. (See Figure 8).
10. Using high heat silicone or furnace cement run heavy bead of caulking around where back of panels meet stove. (See Figure 8).
11. Slide unit back into fireplace. Check to be sure that trim panels (and outer trim) are properly positioned and lie flat against front of fireplace. If panels are out of position, slide unit out and reset by loosening mounting screws and repositioning in slot. Lift stove up in front by using the bar. Place insulation across the bottom and surface of hearth, or bottom of fireplace, to make complete seal.
12. To check seal of panels, use candle flame and go around entire area sealed by silicone and insulation. If flame leans toward inside of fireplace, add additional insulation. This ensures an airtight seal.

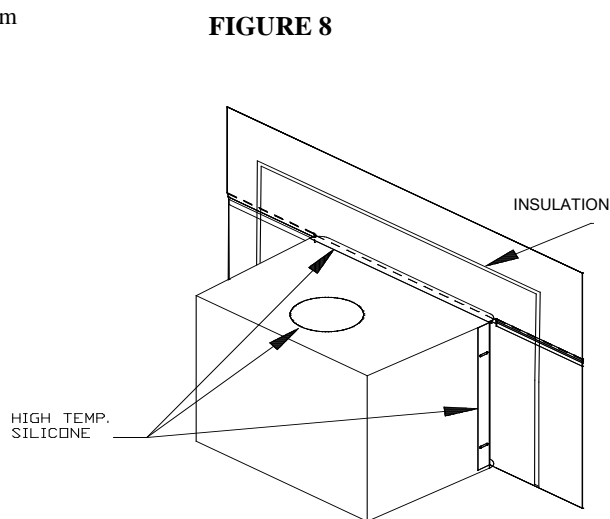
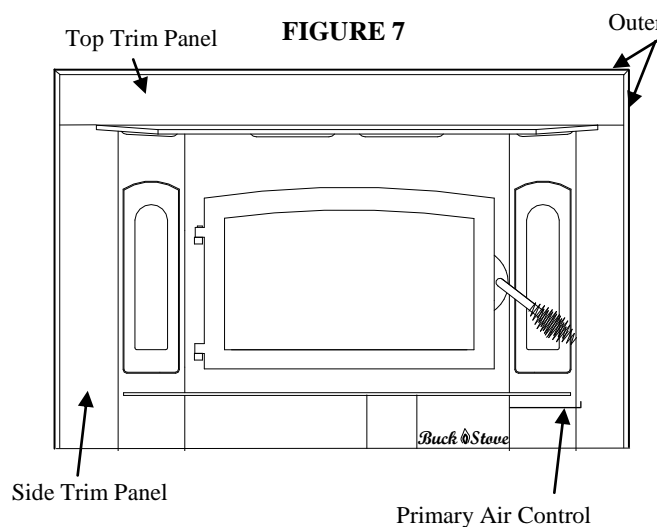

## FINAL CHECK

1. Recheck specified clearances.
2. Remove all foreign material from firebox area.
3. Open primary air control. Primary Air Control: The primary air intake draft control is located at right bottom side of hearth. It is operated by moving handle out to open (to allow air into firebox) or in (to control or close off) to let air into firebox. (See Figure 7).
4. Plug power cord into a 115V AC outlet. Do not run cord under unit or in high traffic areas.
5. Place crumpled pieces of newspaper in stove. Light it and close door. Ensure that stove draws properly through primary draft.

**NOTE: Do not use grate or elevate fire. Build wood fire directly on fire box bottom.**

6. Check for smoke leaks around door.
7. Open door and check for smoke escaping from front of stove. Smoking usually indicates a defective or poorly positioned chimney. Some chimneys with a marginal draft can be pre-heated by lighting newspaper and holding it near open damper. Once chimney heats up, a proper draft can usually be obtained.

If a thorough review of Troubleshooting Guide in rear of manual does not reveal problem, contact your dealer for assistance.

## **CAUTION**

**THE UNIT IS PAINTED WITH A SPECIALLY FORMULATED HIGH TEMPERATURE PAINT THAT CURES DURING THE FIRST TWO OR THREE FIRES. YOU MAY NOTICE A SLIGHT SMOKING EFFECT AND AN ODOR OF BURNING PAINT WHEN YOU BUILD THE FIRST FIRE. THIS IS NORMAL AND IS NOT A CAUSE FOR ALARM. IN SOME CASES, THESE FUMES WILL ACTIVATE A SMOKE ALARM. OPENING A WINDOW NEAR THE UNIT WILL ALLOW THESE FUMES TO ESCAPE. DO NOT BUILD A LARGE, ROARING FIRE UNTIL THIS CURING IS COMPLETE OR THE HEATER FINISH MAY BE DAMAGED.**

The connector and/or chimney should be inspected at least once a month during the heating season to determine if a creosote build up has occurred.

## **CAUTION**

**NEVER USE GASOLINE, GASOLINE-TYPE LANTERN FUEL, KEROSENE, CHARCOAL LIGHTER FLUID OR SIMILAR LIQUIDS TO START OR "FRESHEN UP" A FIRE. KEEP ALL SUCH LIQUIDS WELL AWAY FROM THE STOVE WHEN IT IS IN USE. ALL FLUIDS OF THIS TYPE GIVE OFF VOLATILE FUMES AND CAN AND WILL EXPLODE!! DON'T TAKE A CHANCE WITH THE SAFETY OF YOUR HOME AND FAMILY.**

# SECTION IV

## RESIDENTIAL FREESTANDING INSTALLATION

Select an installation location that will give best airflow from front of heater to remainder of home.

### PREPARING STOVE FOR INSTALLATION

1. Inspect unit for any obvious physical damage.
2. Plug power cord into a 115V AC outlet to test motor. Do not run power cord under unit or in high traffic areas.
3. Check primary air and control to ensure that it slides freely.
4. Remove any items from within firebox. Spread a dropcloth on floor behind heater. Next, tilt heater so that back is on drop cloth.
5. If leg kit is to be used follow steps 1-4.
6. Obtain four legs, attach legs to holes in bottom of unit with bolts and washers. (See Figure 9).
7. Reposition heater to upright position.

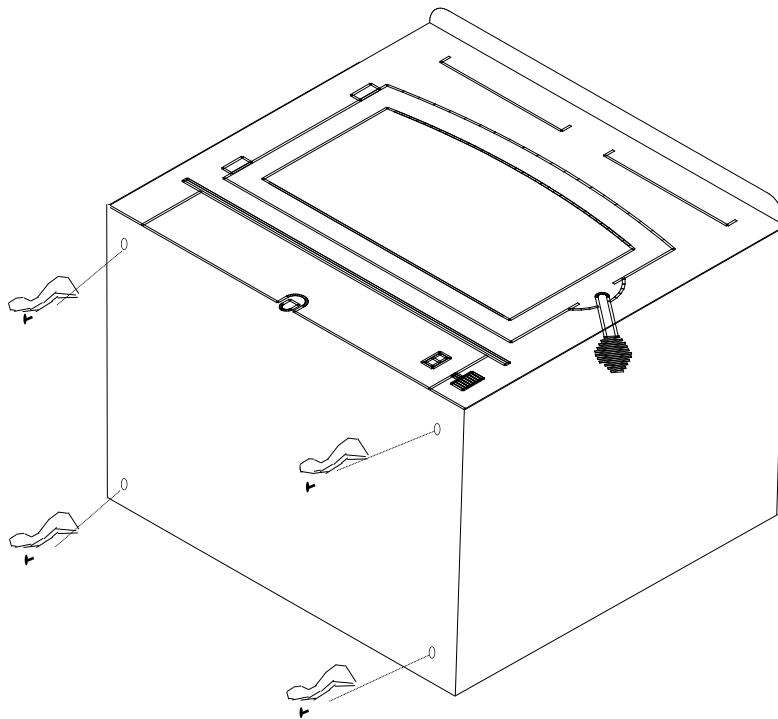

Figure 9

## Chimney

This model is designed for connection to any listed 2100° UL103 HT chimneys and parts. Follow chimneys manufacturer's instructions carefully.

This room heater must be converted to (1) a chimney complying with the requirements for Type HT chimneys in the Standard for chimneys, Factory-Built, Residential, Type and Building Heating Appliance, UL 103, or (2) a code approved masonry chimney with a flue liner. The chimney size should not be less than or more than three times greater the cross-sectional area of the flue collar.

## Floor Protection:

Floor protection must be 3/8" minimum thickness non-combustible material or equivalent, and have an R-value of 0.30.

### How to use alternate materials and how to calculate equivalent thickness

An easy means of determining if a proposed alternate floor protector meets requirements is to follow this procedure:

1. Convert specification to R-value:
  - R-value is given—no conversion is needed.
  - K-factor is given with a required thickness (T) in inches:  
C-factor is given:  $R=1/C$
2. Determine the R-value of the proposed alternate floor protector.
  - Use the formula in step (1) to convert values not expressed as "R"
  - For multiple layers, add R-values of each layer to determine the overall R-value.
3. If the overall R-value of the system is greater than the R-value of the specified floor protector, the alternate is acceptable.

#### Example:

The specified floor protector should be 3/4" thick material with a K-factor of 0.84.  
The proposed alternate is 4" brick with a C-factor of 1.25 over 1/8" mineral board with a K-factor of 0.29.

Step (a): Use formula above to convert specification to R-value.  $R= 1/K \times T = 1/0.84 \times .75 = 0.893$

(Continued on next page)

Step (b): Calculate R of proposed system. 4” brick of C=1.25, therefore Rbrick = 1/C = 1/1.25 =0.80 1/8” mineral board of K = 0.29, therefore Rmin.bd. =1/029 x0.125 = 0.431

Step (c): Compare proposed system R of 1.231 to specified R of 0.893. Since proposed system R is greater than required , the system is acceptable.

Definitions:

$$\text{Thermal conductance} = C = \frac{\text{Btu}}{(\text{hr})(\text{ft}^2)(\text{°F})} = \frac{\text{W}}{(\text{m}^2)(\text{°K})}$$

$$\text{Thermal conductance} = K = \frac{(\text{Btu})(\text{inch})}{(\text{hr})(\text{ft}^2)(\text{°F})} = \frac{\text{W}}{(\text{m})(\text{°K})} = \frac{(\text{Btu})}{(\text{hr})(\text{ft})(\text{°F})}$$

$$\text{Thermal conductance} = R = \frac{(\text{ft}^2)(\text{hr})(\text{°F})}{\text{Btu}} = \frac{(\text{m}^2)(\text{°K})}{\text{W}}$$

Install in accordance with 24 CFR, Part 3280 (HUD).

## CAUTION

**SPECIAL METHODS ARE REQUIRED WHEN PASSING THROUGH A WALL OR CEILING. SEE INSTRUCTIONS AND BUILDING CODES. “DO NOT CONNECT THIS UNIT TO A CHIMNEY FLUE SERVING ANOTHER APPLIANCE.**

### DETERMINING CHIMNEY LOCATION

**A. CEILING EXIT** (Using 8” inch Diameter Residential Single Wall (minimum 24-ga.) Black Chimney Connector and any listed 2100 UL 103 HT type Chimney System ).  
(See Page 14).

1. Suspend a plumb bob from ceiling above unit so that weight is hanging in center of flue exit, (a small weight on a string will serve as a plumb bob). Mark ceiling where string is suspended to locate center of chimney.
2. After locating center of hole, install ceiling support box, chimney flashing and rain cap per chimney manufacturer’s instructions.

Now connect stove and ceiling support box using #24 ga. minimum blue or black steel connector pipe (**DO NOT USE GALVANIZED PIPE**). Connect each section so crimped end faces downward, and secure each section to each other using at least three (3) sheet metal screws or rivets. Also use three (3) sheet metal screws to fasten pipe to collar on heater. (See Figure 10. Page 15).

## Installing a thimble through combustible wall

### Chimney Connector Systems and Clearances from Combustible Walls for Residential Heating Appliances

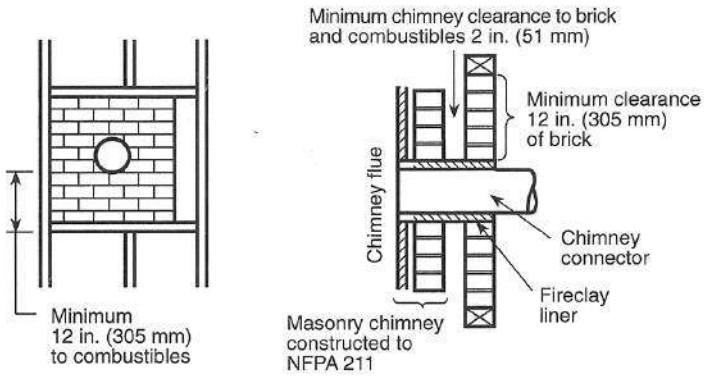

- a) Minimum 3.5-in thick brick masonry all framed into combustible wall with a minimum of 12-in brick separation from clay liner to combustibles. The fireclay liner shall run from outer surface of brick wall to, but not beyond , the inner surface of chimney flue liner and shall be firmly cemented in place.

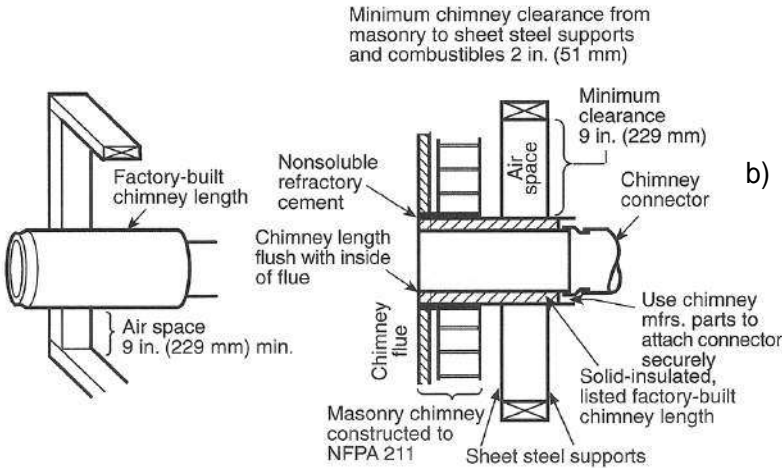

- b) Solid-insulated factory-built chimney length of the same inside diameter as chimney connector and having 1-in. or more of insulation with a minimum 9-in. air space between outer wall of chimney length and combustibles.

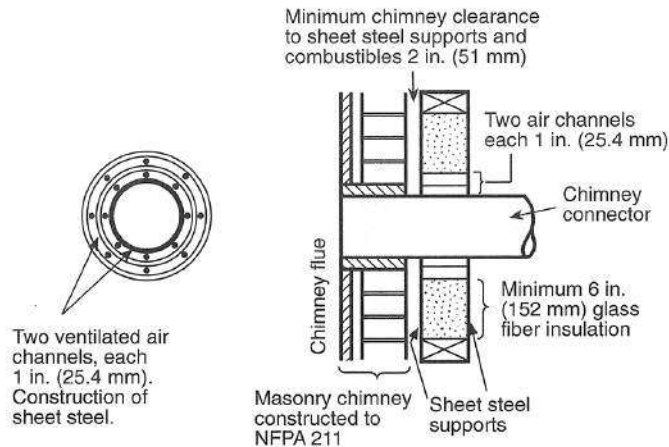

- c) Sheet steel chimney connector, minimum 24 gauge in thickness, with a ventilated thimble, minimum 24 gauge in thickness, having two 1-in. air channels, separated from combustibles. by a minimum of 6-in. of fiber insulation. Opening shall be covered, and thimble supported with a sheet steel support, minimum 24 gauge in thickness.

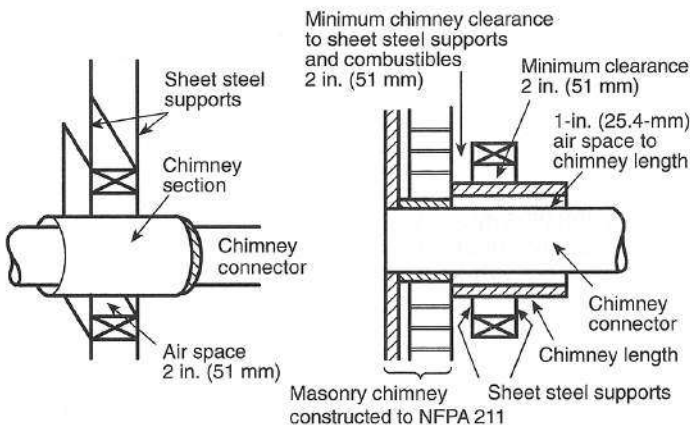

- d) Solid insulated, listed factory-built chimney length with an inside diameter 2-in. larger than chimney connector and having 1-in. or more of insulation, serving as a pass-through for a single wall sheet steel chimney connector of minimum 24 gauge thickness, with a minimum 2-in. air space between outer wall of chimney section and combustibles. Minimum length of chimney section shall be 12-in. chimney section spaced 1-in. away from connector using sheet steel support plates on both ends of chimney section. Opening shall be covered, and chimney section supported on both sides with sheet steel supports securely fastened to wall surface of minimum 24 gauge thickness. Fasteners used to secure chimney section shall not penetrate chimney flue liner.

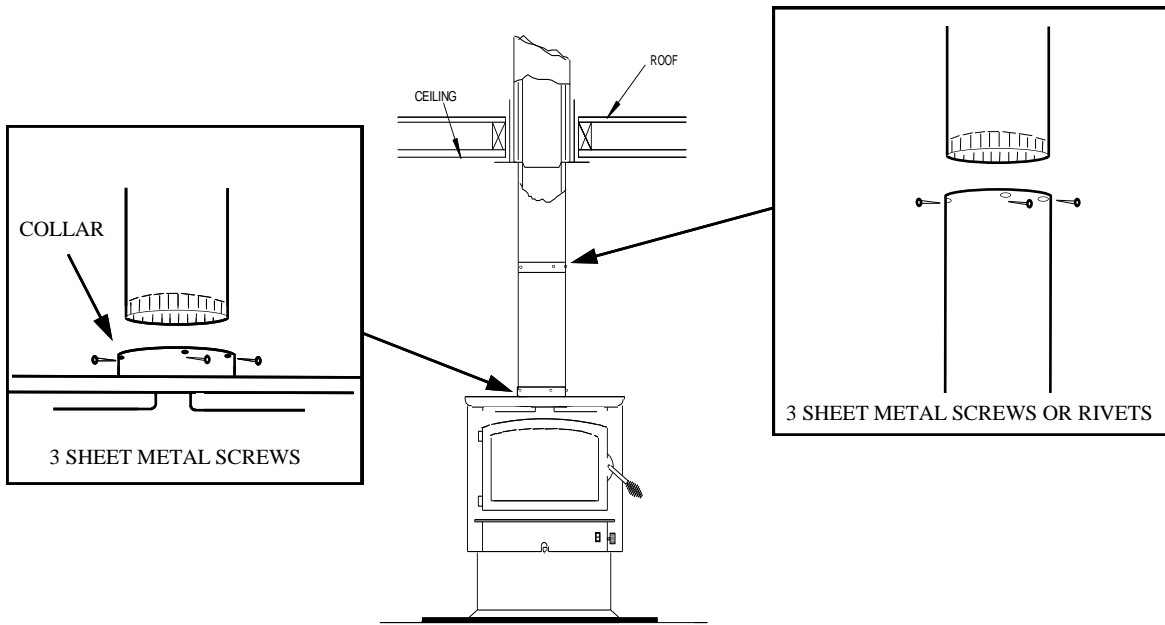

Figure 10

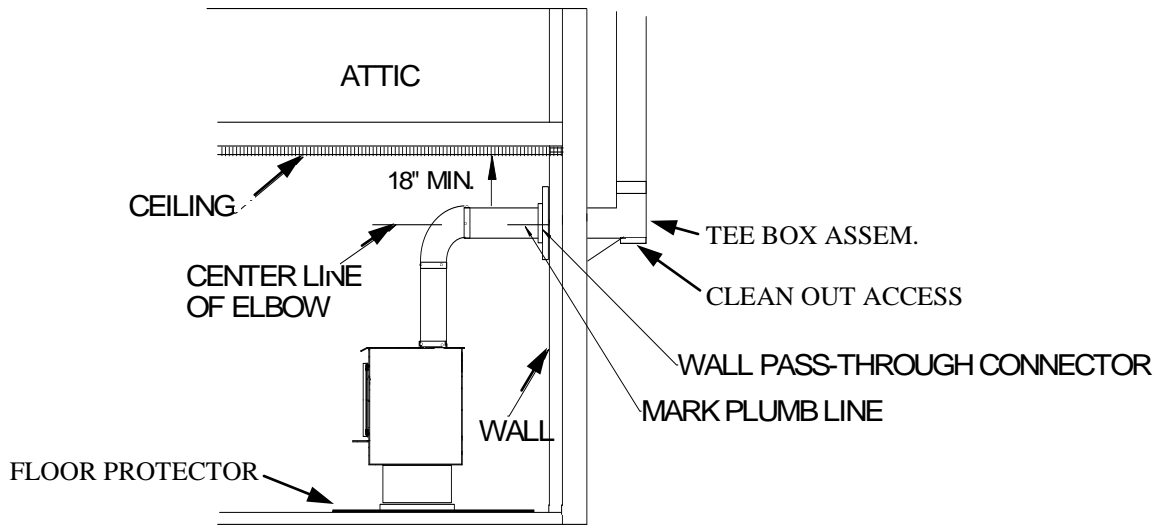

Figure 11

### B. Wall Exit Into Metal Tee-Box

1. Mark plumb line on wall directly behind center of heater. (See Figure 11).  
**NOTE:** When using 24# ga. minimum blue or black steel pipe, maintain 18" between pipe and ceiling.  
**NOTE:** Floor protector must be under horizontal pipe exit (See Figure 13. Page 19).
2. Place vertical portion of heater pipe and elbow in position and project a point onto plumb line level, using the center of your elbow.

3. Measure up so there will be at least 1/4" rise per foot of horizontal connector pipe, maintaining clearances to ceiling as noted in Figure 12. This will give you center hole for chimney penetration.
4. After locating center of penetration, install tee-box and chimney, as per chimney manufacturer's specifications.
5. Connect chimney connector to tee-box using #24 ga. minimum blue or black steel connector pipe. DO NOT use galvanized pipe. Connect each section so the crimped end faces downward, and secure each section to each other using three (3) sheet metal screws or rivets. (See Figure 10. Page 15).

### C. Wall Exit Into Masonry Flue (Using Single Wall Pipe)

1. Before connecting these units to a masonry chimney, determine that masonry flue passing through connector thimble meets NFPA-211 Code and local building codes. It must be a minimum of 18" from ceiling. If connector thimble does not meet these codes, pass-through connector must be modified.

**NOTE:** Floor protector must be under horizontal pipe exit (See Figure 13. Page 19).

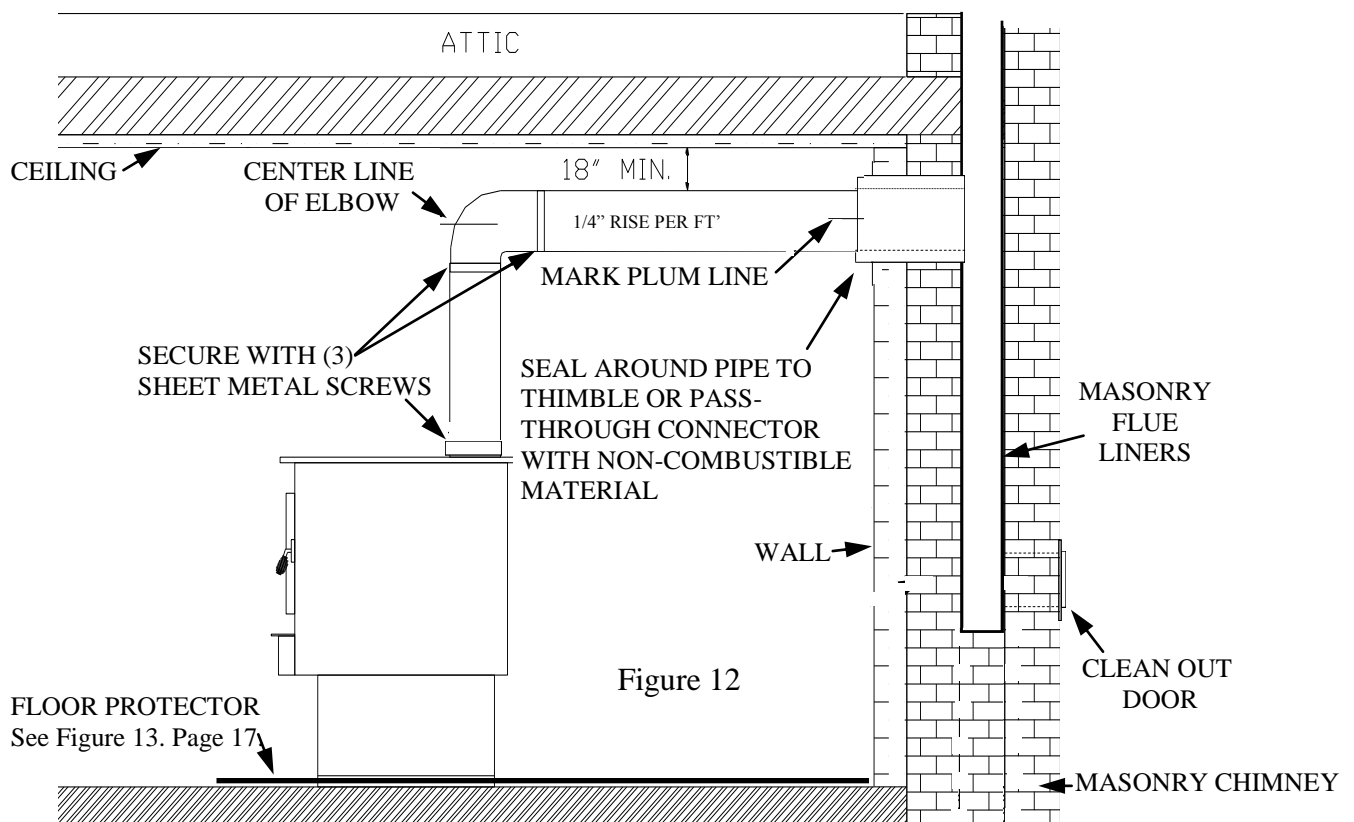

Connectors may pass through walls or partitions constructed of combustible material if connector is:

- (a) Either listed for wall pass-through or is routed through a device listed for wall pass-through. It must be installed in accordance with conditions of listing.
- (b) Selected or fabricated in accordance with conditions and clearances as stated in **NFPA-211** Code. Any unexposed metal that is used as part of a wall pass-through system and is exposed to flue gases shall be constructed of stainless steel or other equivalent material.

In addition, a connector to a masonry chimney shall extend through wall to the inner face or liner but not beyond, and shall be firmly cemented to masonry.

**EXCEPTION:** A thimble may be used to facilitate removal of the chimney connector for cleaning, in which case the thimble shall be permanently cemented in place with high-temperature cement.

2. Once through-the-wall thimble codes are met, simply connect chimney collar to wall pass through connector using #24 ga. minimum, blue or black steel connector pipe as follows:
  - (a) Maintain 1/4" rise per foot (horizontal length) from appliance to chimney.
  - (b) Connect each section so crimped end faces downward.
  - (c) Secure each section to each other using at least three (3) sheet metal screws or rivets (See Figure 10. Page 15).
  - (d) Use three (3) sheet metal screws to fasten pipe to connector collar on heater. (See Figure 10. Page 15).

## FINAL CHECK

1. Recheck specified clearances.
2. Remove all foreign material from firebox area.
3. Open primary air control. **Primary Air Controls:** The primary air intake control is located at right bottom side of hearth. It is operated by moving the handle **out** to open (to allow air into the firebox) or **in** to control or close off the firebox.
4. Plug power cord into a 115V AC outlet to see if motor and blower works. Do not run power cord under unit or in high traffic areas.
5. Place crumpled pieces of newspaper in stove. Light it and close door. Ensure that stove draws properly through primary draft.
6. Check for smoke leaks around door.

### CAUTION

**Open door and check for smoke escaping from front of the stove. Smoking usually indicates a defective or poorly positioned chimney. Some chimneys with a marginal draft can be preheated by lighting newspaper and holding it near open damper with a poker or fire tong. Once chimney heats up, a proper draft can usually be obtained.**

If review of Troubleshooting Guide does not reveal problem, contact your dealer for assistance.

### CAUTION

**The unit is painted with a specially formulated high temperature paint that cures during the first two or three firings. You may notice a slight smoking effect and an odor of burning paint when you build the first fire. This is normal and is not a cause for alarm. In some cases, these fumes will activate a smoke alarm. Opening a window near unit will allow these fumes to escape. DO NOT build a large, roaring fire until this curing is complete or heater finish may be damaged.**

# CLEARANCES FOR MODEL 94NC

## MINIMUM CLEARANCES TO COMBUSTIBLES RESIDENTIAL SINGLE WALL CONNECTOR

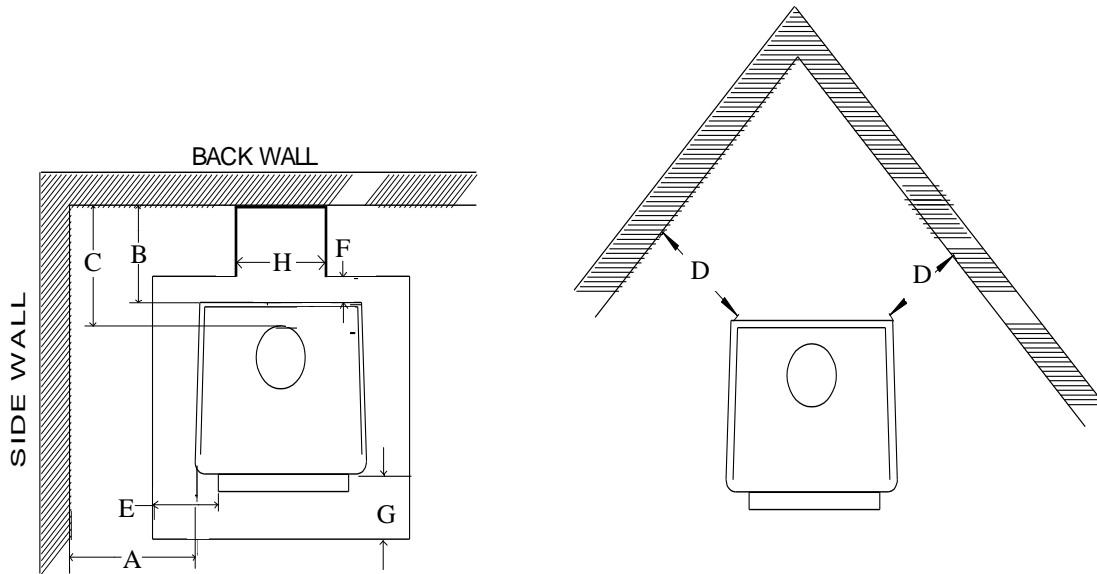

Figure 13

	A	B	C	D	E	F	G	H
MODEL 94NC	22"	23"	26"	23"	8"	6"	16"	12"

**NOTE:** All clearances are to combustibles using single wall pipe, minimum floor protector. Minimum floor protection under unit must have an R-value of 0.30. (see page 12, 13)

**NOTE:** The clearances above may be reduced, follow NFPA-211 codes.

For wall exit, floor protector must be under horizontal pipe. There must be 2" on each side of pipe. Maintain 18" between pipe and ceiling.  
(See Figure 13, measurements F & H).

## SECTION VI

# WOOD HEATER SAFETY

Certain safety hazards are inherent in any wood heater installation. You should be aware of these so that a safe and proper installation can be made.

1. **FAULTY CHIMNEY:** An older masonry chimney should be thoroughly checked to be sure there are no holes or weak spots, which could allow sparks or hot gases to escape.
2. **HEAT CONDUCTION:** Placing combustible materials too close to a heater or chimney can be a fire hazard.

By keeping these particular hazards in mind as you install and use your room heater you can ensure a safe, reliable installation.

The chimney and chimney connector should be inspected once every two months. Any build-up of soot should be removed to prevent the risk of a chimney fire. To remove chimney or chimney connector, remove screws or fasteners. Remove pipe and clean with steel brush. Replace chimney or chimney connector, and replace screws and/or fasteners.

### CAUTION

**NEVER USE GASOLINE, GASOLINE TYPE LANTERN FUEL, KEROSENE, CHARCOAL LIGHTER FLUID OR SIMILAR LIQUIDS TO START OR "FRESHEN UP" A FIRE IN THE HEATER. KEEP ALL SUCH LIQUIDS WELL AWAY FROM THE STOVE WHEN IT IS IN USE. ALL FLUIDS OF THIS TYPE GIVE OFF VOLATILE FUMES AND CAN AND WILL EXPLODE!! DON'T TAKE A CHANCE WITH THE SAFETY OF YOUR HOME AND FAMILY.**

**CAUTION: Never remove ashes from heater with blower running.**

**DISPOSAL OF ASHES:** Ashes should be placed in a metal container with a tight fitting lid. The closed container of ashes should be placed on a non-combustible floor or on the ground, well away from all combustible materials pending final disposal. If ashes are disposed of by burial in soil or otherwise locally dispersed, they should be retained in closed container until all cinders have thoroughly cooled.

**CREOSOTE-FORMATION AND NEED FOR REMOVAL:** When wood is burned slowly, it produces tar and other organic vapors, which combine with expelled moisture to form creosote. The creosote vapors condense in the relatively cool chimney flue of a slow-burning fire. As a result, creosote residue accumulates on the flue lining. When ignited this creosote makes an extremely hot fire.

## SECTION VII OPERATION

This section of the manual is to help you get maximum efficiency and maximum smoke (particulate) reduction from your heater. If you should experience any difficulty or have any questions concerning your heater, contact your dealer for assistance. **NOTE: The manufacturer recommends that for maximum performance burn natural seasoned hard wood.**

**Build a fire for maximum efficiency.** This model burns wood and extracts heat so efficiently, a large fire is not necessary. A large fire not only wastes energy, it usually results in home being too warm for comfort.

The following steps will serve as a guide for operating your stove.

### BUILDING A FIRE

1. Open door.
2. Open primary air control. **Primary Air Controls:** The primary air intake draft control is located at right bottom side of hearth. It is operated by moving handle **out** to open (to allow air into firebox) or **in** (to control or close off) to let air into firebox.
3. Twist two pieces of non-colored newspaper into a roll and place them on floor of firebox. **NOTE: Do not use grate or elevate fire. Build wood fire directly on inner bottom of fire box.**
4. This model is not designed for use of grates, andirons or other methods of supporting fuel.
5. Lay several pieces of dry kindling on top of newspaper.
6. Place three or four small pieces of firewood, 2"-3" in diameter, on top of kindling.
7. Light newspaper in front. Close and latch door. Don't leave fire unattended at this point. The draft system of heater should start quickly. It may be necessary to preheat chimney to get draft started. To do this, open door and add newspaper to top rear of wood. Light or let this paper ignite and allow to burn while holding the door slightly cracked. Once draft has started, close and lock door. You are over-heating the unit if the chimney and or connector glows red.
8. **NOTE: After embers and a coal bed have been established, load heater with seasoned natural hard wood, placing it front to rear.**

**NOTE: THE FUELING DOOR MUST REMAIN CLOSED DURING OPERATION.**

BURN RATE:	LOW	MED-LOW	MED-HI	HI
AIR SETTINGS:	1/32"	5/32"	9/32"	WIDE OPEN

**Your stove is equipped with an automatic thermostat. When stove gets hot enough, thermostat will activate room air blower. Set fan speed on low, when burning on low, med-low or med-high. Set fan speed on high when burning on high.**

**NOTE: When refueling or removing ashes turn "OFF" room air blower. Be sure to turn room air blower back on when finished.**

**NOTE: Do not run power cord underneath heater or in walk way or heavy traffic areas.**

# ROOM AIR BLOWER OPERATION

Your heater is equipped with a room air blower. For operation and wiring see figure 14.

For your convenience your heater is equipped with a rheostat with which you are able to select air flow. The auto and manual switch will allow you to select the position at which thermostat will function.

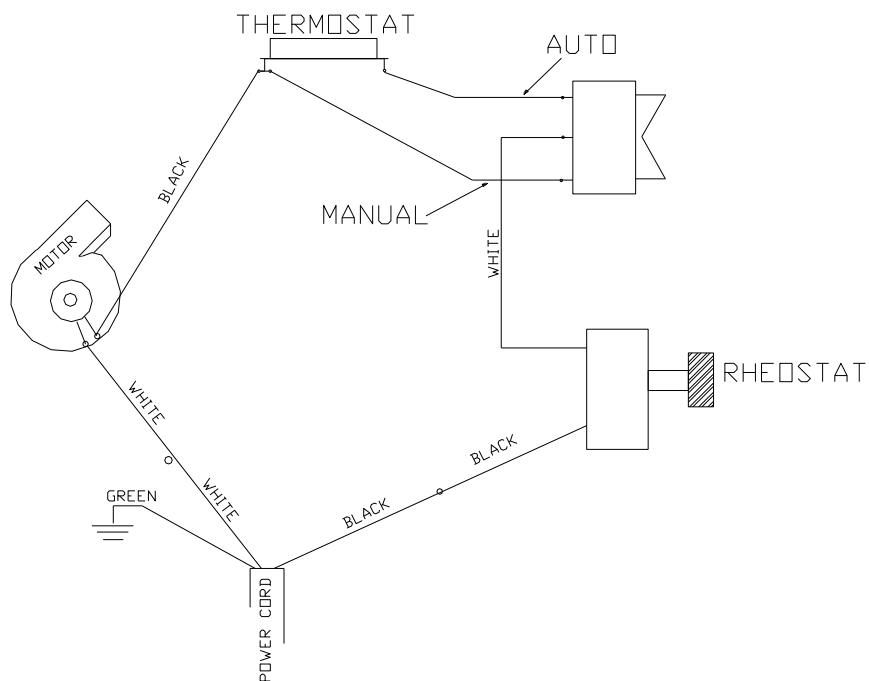

Figure 14

**Auto-position:** After heater has warmed up and Auto-Manual switch is placed in “Auto” position and rheostat is in desired position, the fan will automatically come on. When stove cools off fan will automatically shut-off.

**Manual position:** You must turn room air blower on and off.

**NOTE:** Plug power cord into a 115V AC outlet. Set switch to “Manual” and rheostat to “High” position to ensure motor operates properly. Route cord to prevent damage to cord insulation from heat and sharp objects. Keep cord out of the way of traffic to prevent damage caused by tripping, etc.

**SECTION VIII  
TROUBLESHOOTING**

<b>PROBLEM</b>	<b>POSSIBLE CAUSE</b>	<b>SOLUTION</b>
Sluggish Heater	Obstruction in chimney	Check for and remove obstruction
	Improperly sealed trim kit or direct connect kit	(a) Check trim kit gasketing seal to fireplace and gasket as necessary to seal unit. Gasket under front bottom of stove if needed. (b) Check seal if using direct connect and correct.
	Manual damper in chimney is closed	Open manual damper and wire shut with stainless steel wire or remove damper
	Wet or unseasoned wood being burned	Burn dry, natural seasoned hard wood
	Poor chimney draft	Improper chimney height or wrong size flue is being used. Cooler temperatures caused by external chimney
	Improper wood loading	Load wood from front to rear

# TROUBLESHOOTING

(Continued)

PROBLEM	POSSIBLE CAUSE	SOLUTION
High fuel consumption	Improper regulation of draft or inlet air	(a) Close inlet air control as much as possible to maintain desired heat output (b) Check gaskets, reinstall fiberglass gasketing round doors and glass as necessary
	Improper door fitting	Check door gasket, check adjustment of door latch
Backpuffing	Gusts of Wind	(a) Smoke shelf in chimney is filled with creosote & ash (b) Chimney may need wind diverter. Raise chimney for better draft
Smoke rollout when heater door is opened	Wind gusts blowing down the chimney	(a) Smoke shelf in chimney is filled with creosote & ash (b) Chimney may need wind diverter. Raise chimney for better draft
	Opening heater door too fast	Crack door for 15 seconds before fully opening door

# REPLACEMENT PARTS FOR MODEL 94NC

Description	Part Number
1. Primary Air Handle	PS 94NC040
2. Door Handle Assembly	PA 910096
3. Door Latch	PC 910098
4. Door Handle Washer	PO 91WASH
5. Front Door Bushing	PO 910102
6. Door	PC 912651
7. Carling Fan Auto/Man Switch	PE RC211RB
8. Thermostat 110° Disc	PE 400132
9. Power Cord	PE 400240
10. Strain Relief	PE 400320
11. Motor	PE 910714
12. Rheostat	PE BC204
13. Rheostat Knob	PE BC204A
14. Glass	PG 265191GL
15. Glass (Bay Side)	PG 27BSGL
16. Bay Glass Overlay	PO 910454G
17. Glass Clip	PO 912651
18. Glass Clip Screws	PH 103212HWSPS5
19. Spring Handle	PO 100150B
20. "U" Drive Screw (5/16" x 1/2")	PO 516U
21. Front Secondary Air Tube	PO 94NC010
22. Rear Secondary Air Tube	PO 94NC012
23. Primary Shotgun & Air Block	MF 910080
24. Top Baffle Board	PO BPF94
25. 1" x 1" x 1/8" Thick Magnet	PO DM841
26. Firebrick	PR 900050
27. Motor Guard Screen	PS 910105

**NEW BUCK CORPORATION (NBC)**  
**"LIMITED WARRANTY" FOR THE BUCK STOVE**  
**PLEASE READ THIS WARRANTY CAREFULLY**

**PRODUCTS COVERED**

This warranty covers the new Buck Stove heating unit, so as long as it is owned by the original purchaser, including optional and standard accessories purchased at the same time, subject to terms, limitations, and conditions set out herein .

**PRODUCTS NOT COVERED**

This warranty does not cover the following:  
Glass, Refractory Material, Firebrick or Gaskets.

This Warranty will not cover any damage and/or failure caused by abuse or improper installation of the products covered.

**WARRANTY TIME PERIODS**

**(A) Period I**

For one year from the date of purchase, NBC will replace or repair, at its option, any part defective in materials or workmanship. The costs of parts are included. The customer pays any labor or transportation charges required.

**(B) Period II**

For the period after the first year from the date of purchase and extending for five years as long as the Buck Stove is owned by the original purchaser, NBC will repair or replace at its option, any part defect in materials or workmanship with the exception of: electrical motors, wiring, switches, components, optional standard accessories, and all parts not permanently attached to the heating unit. Parts not permanently attached to the heating unit are defined as those items designed to be removed from the stove, including those removable with common hand tools. The costs of parts only are included. The customer pays any labor or transportation charges required.

**PROCEDURE**

Should you feel that your BUCK STOVE is defective, you should contact any Buck Stove dealer for the name of your nearest authorized Buck Stove service representative, who will instruct you on the proper procedure, depending on which Warranty Time Period (Period I or Period II) applies.

If for any reason you are dissatisfied with the suggested procedures, you may contact us in writing at:

New Buck Corporation  
Customer Service Department  
P. O. Box 69  
Spruce Pine, NC 28777  
Email: info@buckstove.com

**CONDITIONS AND EXCLUSIONS**

- (A) Replacement of parts may be in the form of new or fully reconditioned parts, at NBC's option.
- (B) There is no other express warranty. All implied warranties of merchantability and fitness for use are limited to the duration of the Express Warranty.
- (C) New Buck Corporation is not liable for indirect, incidental, or consequential damages in connection with the use of the product including any cost or expense of providing substitute equipment or service during periods of malfunction or non-use. Some states do not allow the exclusion of incidental or consequential damages, so the above exclusion may not apply to you.
- (D) All warranty repairs under this warranty must be performed by an authorized Buck Stove service representative. Repairs or attempted repairs by anyone other than an authorized service representative are not covered under this warranty. In addition, these unauthorized repairs may result in additional malfunctions, the correction of which is not covered by warranty.

**OTHER RIGHTS**

This warranty gives you specific legal rights. You may also have other rights which vary from state to state.

**OWNER REGISTRATION CARD**

The attached Owner Registration Card must be completed in its entirety and mailed within 30 days from the date of purchase or from the date of installation, if installed by a factory certified installer, to New Buck Corporation in order for warranty coverage to begin.

**PLEASE NOTE:** The Owner Registration Card must contain the Authorized Buck Stove Dealer Code Number and the Certified Installer's number (if applicable) for warranty coverage to begin.

To be completed by selling distributor/dealer/ customer:

Name \_\_\_\_\_  
(Last) (First)

Address \_\_\_\_\_

City \_\_\_\_\_ State \_\_\_\_\_ Zip \_\_\_\_\_

*CUSTOMER EMAIL:* \_\_\_\_\_

**MODEL NC94** - Serial Number \_\_\_\_\_

Date of Installation: Day \_\_\_\_\_ Month \_\_\_\_\_ Year \_\_\_\_\_

Installer's Name \_\_\_\_\_

Installer's Certification Number \_\_\_\_\_

Dealer's Name \_\_\_\_\_

City \_\_\_\_\_ State \_\_\_\_\_ Zip \_\_\_\_\_