

BuckMaster

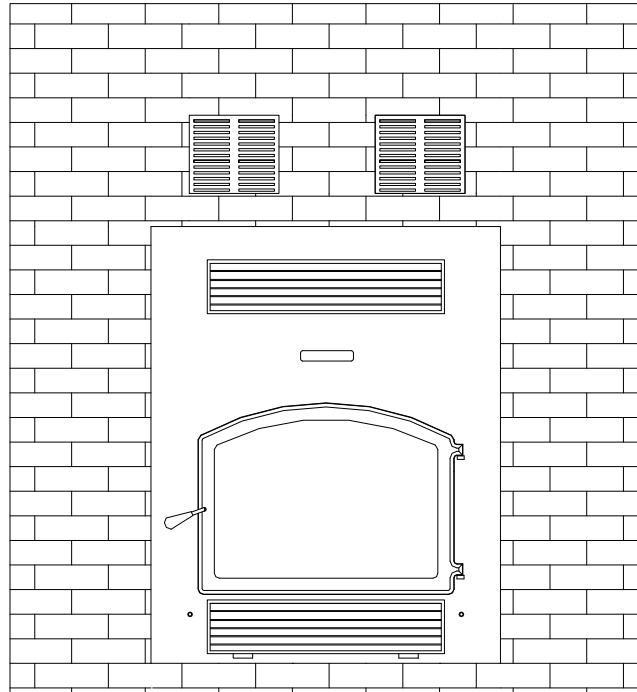

IMPORTANT: INSTALLATION MUST BE MADE IN ACCORDANCE WITH STATE AND LOCAL ORDINANCES WHICH MAY DIFFER FROM THIS INSTALLATION MANUAL.

CAUTION: READ RULES FOR SAFE OPERATION AND INSTRUCTIONS

BuckMaster AIR-TIGHT ZERO CLEARANCE FIREPLACE INSTALLATION/OPERATOR'S MANUAL

FOR YOUR SAFETY - Do not store or use gasoline or other flammable vapors and liquids in the vicinity of this or any other appliance.

Manufactured by New Buck Corp.
Spruce Pine, NC 28777

Effective April, 2003

TABLE OF CONTENTS

INTRODUCTION.....	3
GENERAL INFORMATION AND SPECIFICATIONS	3
PLANNING YOUR FIREPLACE INSTALLATION.....	3-4
LOCATING THE FIREPLACE	3
CLEARANCES	3
CHIMNEYS.....	4
TYPICAL INSTALLATION.....	4
INSTALLATION.....	5-20
CHIMNEY	5-6
COMBUSTION AIR DUCT	7
HOT AIR DUCT INSTALLATION	7-13
FIREPLACE DIMENSIONS.....	14
FRAMING-IN AND FINISHING.....	13-17
FAN KIT	18
WIRING DIAGRAM.....	19-20
OPERATION	20
STARTING A FIRE	21
ASH REMOVAL.....	21
CARE AND MAINTENANCE.....	21-24
CATALYTIC COMBUSTOR REPLACEMENT	22-23
BY-PASS DOOR REPLACEMENT	24
TROUBLE SHOOTING	24
CHIMNEY FIRES.....	24
PARTS LISTS	25-27
WARRANTY.....	28

INTRODUCTION

Thank you for your purchase of the BuckMaster Zero-Clearance Fireplace. By following the instructions in this manual you can be assured of an installation that will add both beauty and value to your home as well as provide safe, efficient supplemental heat.

Your BuckMaster dealer can be a valuable source of information in helping select the proper components for your installation as well as recommending professionals who can assist in installation and maintenance.

IMPORTANT INFORMATION

Read these instructions carefully and keep for future reference.

√ Obtain a building permit and check local codes. This installation must comply with their rulings.

√ **NOTE: When burning any unit or appliance that combust fuel for heat, such as coal, oil, wood or natural and (L.P.) liquid petroleum gas. We highly recommend the use of smoke and carbon monoxide detectors in your home.**

√ To prevent injury or damage, do not allow anyone unfamiliar with solid fuel to operate this unit.

√ Do not store fuel or other combustible materials within marked clearances.

√ Do not burn garbage, plastics, "green" wood, composite wood products or coal. These materials can produce gases and by-products that may harm the fire chamber and chimney or produce excessive amounts of creosote.

√ Never start a fire with gasoline, kerosene, charcoal lighter fluid, or other flammable liquids.

√ Use only with approved chimney.

√ Black metal on front of unit is HOT - keep children away.

FIREPLACE SPECIFICATIONS

Emissions 2.7 grams/hr.
Maximum BTU Output/Hr. 54,300
Estimated Heating Capacity 1800 sq. ft.

Height..... 48"
Width..... 38-1/4"
Depth..... 27-3/8"
Flue Size..... 8" I.D.
Hot Air Ducts (Optional)..... 8"
Maximum Log Length..... 24"
Paint..... Flat Black

DISCLAIMER NOTICE

The BTU ranges and heating capacity specifications are provided as guidelines only and in no way guarantee the output or capacity of the unit. In warmer climates, on average, the fireplace can be expected to heat a greater area than indicated.

Other factors which affect the actual area that the unit will heat include: the conditions of the building, heat loss, type of construction, amount of insulation, type of air movements, and location of the unit. The actual BTU output depends on the type and condition of the wood being burned, draft setting and the chimney that the fireplace is hooked up to.

NOTE: Your BuckMaster warranty is at the end of this manual. Be sure to complete and return the warranty registration to the manufacturer. If you have any problem your local dealer cannot help you with, please contact the manufacturer direct.

PLANNING YOUR FIREPLACE INSTALLATION

Before beginning actual installation, it is important to thoroughly plan out the location of the fireplace and how it will be used to provide heat to your home. Read the entire manual to ensure that your installation meets all requirements and that you have the necessary materials and equipment to complete installation.

General Guidelines for Locating the Fireplace

1. Consider how it will be framed and its relation to doors, windows, adjacent walls, and traffic patterns.
2. If possible, locate the fireplace so the chimney can be installed without cutting through floor joists or roof rafters.
3. Determine where a duct can be run to provide outside air to the fireplace for combustion (optional).

CLEARANCES FROM COMBUSTIBLES

Front to Adjacent Wall..... 8"
Non-combustible Hearth..... 20"x46"
Base of Unit to Overhead Combustible..... 49"
Heat Vents to Ceiling..... 18"
Heat Ducts, Approved Chimney Pipe to Combustibles..... 2"
Back, Sides, and Top of Unit..... Flush to Materials
(Built in Spacers)

CLEARANCES TO COMBUSTIBLES

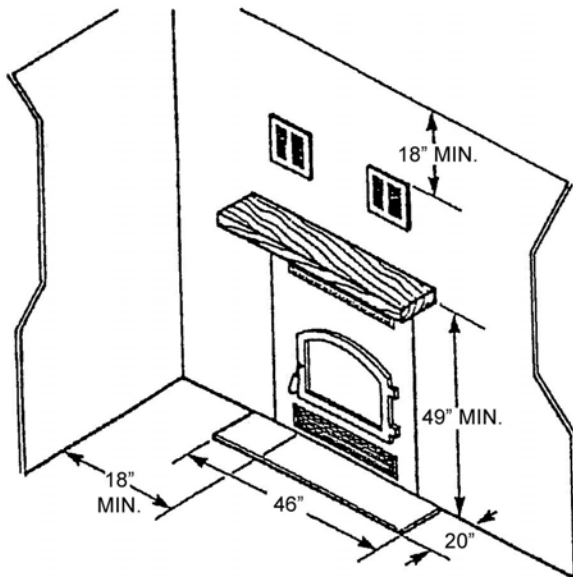

HOT AIR DISTRIBUTION

The high BTU output of the BuckMaster fireplace makes it an excellent heat source. The diagrams on page 8 and 9 show different duct systems that can be used to heat one or more rooms in your home.

CHIMNEY CONSIDERATIONS

1. Any UL-103 (HT-2100 degree) type HT, or ULC-S629 (in Canada) factory build chimney system may be used.

You may connect to a masonry chimney as long as the conditions in section 8 4.5 of NFPA 211 are met. The connector from the flue outlet of the BuckMaster and the masonry chimney must also meet UL 103 type HT requirements, unless the connector is visible from within the room and a minimum clearance to combustibles of 18" (460mm) is maintained.

2. Do not vent any other appliance through the fireplace chimney.

TYPICAL INSTALLATION

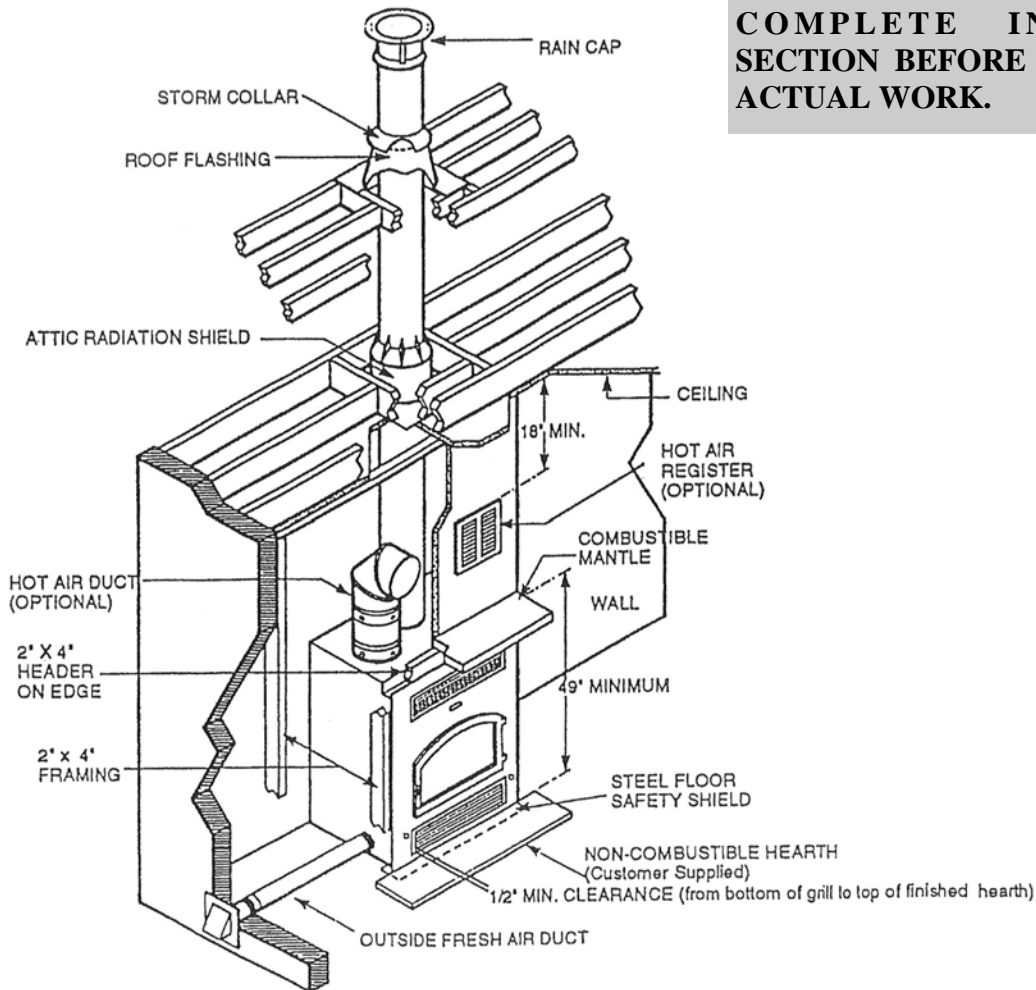

IMPORTANT: CAREFULLY REVIEW COMPLETE INSTALLATION SECTION BEFORE BEGINNING ANY ACTUAL WORK.

INSTALLATION

PARTS NEEDED CHECKLIST:

1. BuckMaster Fireplace
2. Hot air duct kit
3. 6" wide steel floor safety shield
4. Approved Chimney including:
 - Anchor Plate
 - Appropriate number of lengths for proper height
 - 15° or 30° elbows if necessary
 - See chimney installation instructions
 - Firestop radiation shield, Attic radiation shield
 - Roof flashing
 - Rain Cap
 - Supports if necessary

OPTIONAL PARTS

1. Additional hot air ductwork
2. Grill box extension kit
3. Masonry Adapter Kit
4. Temperature probe port extension
5. Non-combustible Face and Hearth
6. Condar temperature probe model 9-85
7. 10" x 10" Grill kit (subject to change)

STRUCTURAL AND FINISHING MATERIALS OPTIONS

1. Framing and sheathing
2. Facing materials: stone, bricks, tile, etc.
3. Premanufactured fireplace surround and hearth
4. Mantel

PLACING THE FIREPLACE

1. Move fireplace into selected location
2. Hearth preparation:

On combustible flooring, raise the front of the fireplace enough to slide the 6" wide steel floor safety shield halfway under the unit. Nail the exposed portion of the strip to the floor. The safety shield provides added protection against hot embers which could fall in between the fireplace and the finished hearth. In all installations consideration must be given to the thickness of the final hearth material. **NOTE:** A clearance of 1/2" minimum must be maintained between the top of the finished hearth and the bottom of the lower grill to ensure that the grill can be fully opened for removal of the ash pan. Elevate the fireplace as required.

CHIMNEY GENERAL INFORMATION

1. A minimum of 3' is required from the top of the chimney to the point where it passes through the roof. In addition, the top of the chimney must be at least 2' higher than any wall, roof ridge or building that is within 10'.

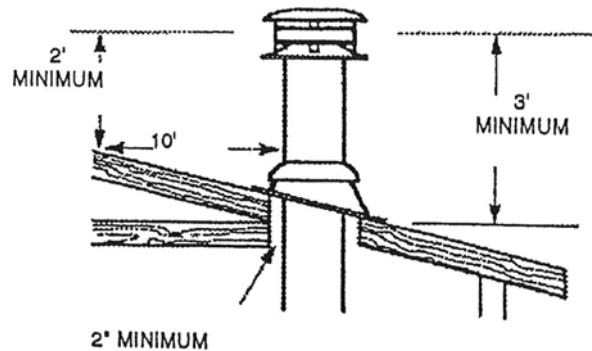

2. Where more than one chimney uses the same chase, or exits the roof in the same location, maintain the clearances shown to prevent smoke being drawn from a warm flue to a cold one. These are suggested clearances only.
3. Whenever possible the entire run of the chimney should be within the structure. The use of an exterior chimney may cause poor draft, excessive condensation and a faster buildup of creosote.

If it is necessary to use an exterior chimney, it should be framed in with an insulated enclosure.

Do not fill the enclosure with loose fill. A 2" clearance must be maintained around the chimney pipe.

4. The fireplace will support a maximum chimney height of 15'. Additional length should be supported at 10' intervals using components specified by the chimney manufacturer.

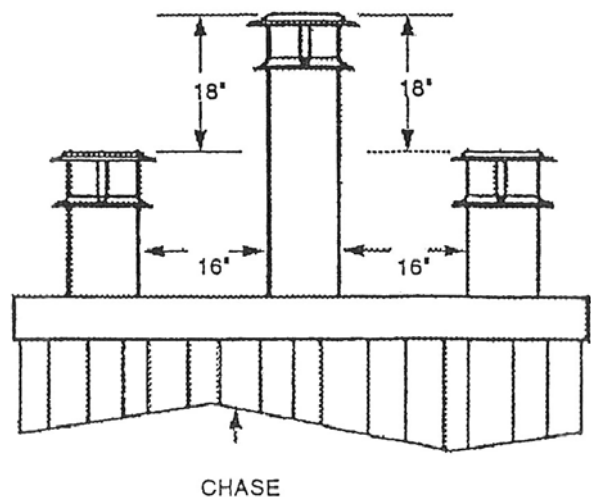

INSTALLING THE CHIMNEY

Follow chimney manufacturer's instructions for proper installation. Be sure the chimney is equipped with the corresponding anchor plate for attachment to the fireplace.

Whenever possible, the chimney should take a straight vertical path to the roof. If a bend is required, use only one angled section with a maximum of two elbows. Only 15° or 30° elbows are approved for this unit. Consult your dealer for selection of components and observe required clearances.

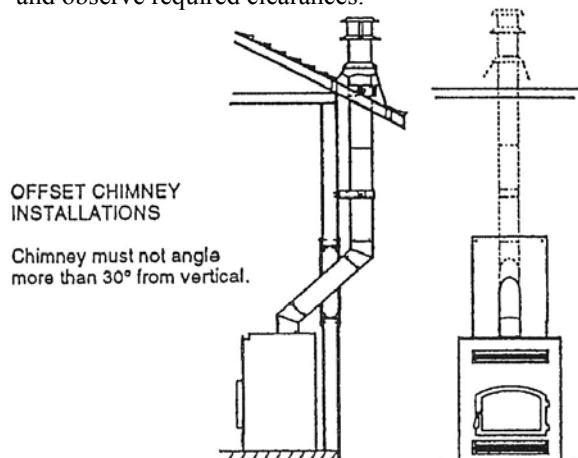

1. Cut and frame in holes in ceiling and roof where chimney will pass with 2" x 4"s. Finished opening should be 13" x 13". Use a plumb bob to line up centers of holes with flue opening on fireplace.
2. Attach a firestop radiation shield on the underside of the framing for each floor that the chimney goes through. At the attic level install an attic radiation shield.

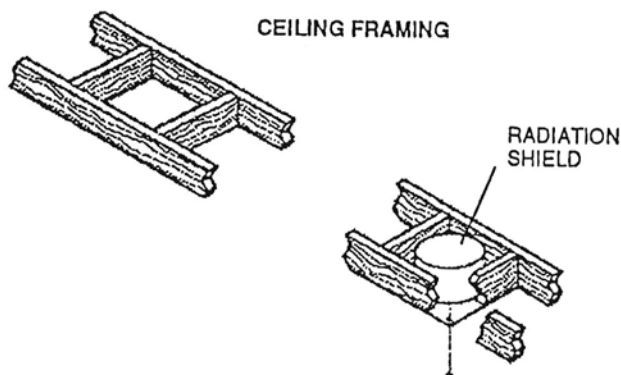

3. Place bead of hi-temp silicone caulk under appropriate chimney anchor plate and push plate collar into fireplace flue. Secure with metal screws. Connect first chimney section per manufacturer's instructions. Continue adding sections until required height is achieved.

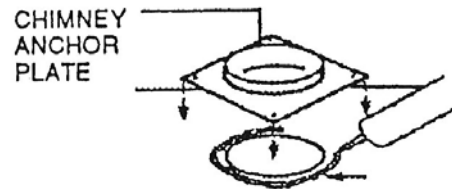

HI-TEMP
CAULK

4. If the chimney is not enclosed and passes through a vented attic space or roof, proceed as follows:
 - A. Slide roof flashing over chimney and seal flashing to roof with roofing compound. If roof is sloped, place top edge of flashing under shingles and bottom edge on top of shingles. Secure with roofing nails.
 - B. Place storm collar over chimney and flashing. Tighten collar and seal joint with good quality caulking compound.
 - C. Install raincap or chimney and secure.
 - D. Clean flashing with vinegar or solvent and apply a coat of rustproof paint.
5. If the chimney is enclosed in the attic it must be fitted with a good radiation shield and vented flashing.

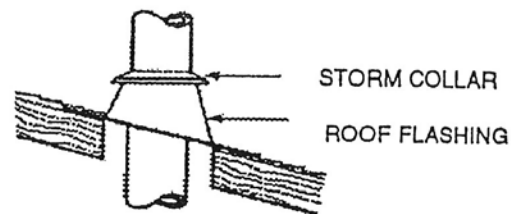

- A. Install radiation shield in roof and attach with four 3/4" screws or 1" nails.
- B. Seal roof flashing to roof with roofing compound. On sloped roofs, place top edge of flashing under shingles and bottom edge on top of shingles. Secure with roofing nails.

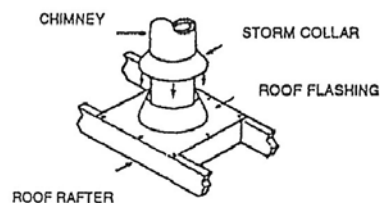

- C. Place storm collar over chimney and push down so collar makes contact with flashing. Seal the collar joint with silicone or high quality caulking.
- D. Install and secure raincap.

COMBUSTION AIR DUCT

It is required that a separate source of outside combustion air be provided for all installations. This is particularly important in well insulated houses. The BuckMaster outside air kit assures proper combustion of the wood. The kit consists of an exterior vent, flexible vent pipe, and mounting hardware.

The BuckMaster Fireplace is equipped with an opening on both sides of the unit for connection of the outside air duct. The actual duct may be run above or below the floor level.

1. Cut a 4 1/4" hole in the outside wall of the house. From the outside, install the vent with the vent openings pointing down.
2. Push one end of the aluminum air duct over the neck of the outside vent and the other end over the fireplace connector.
3. Secure duct at each end with clamps supplied (2).

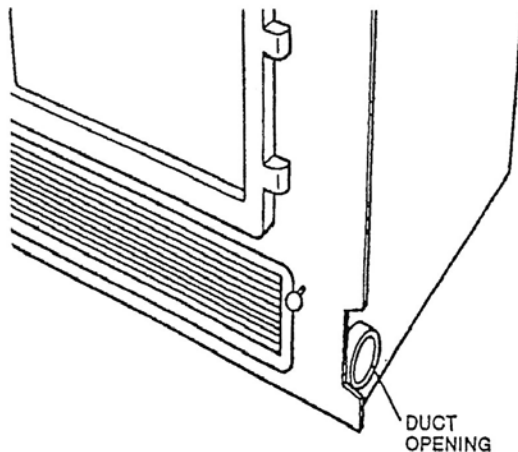

NOTE: Combustion air must be connected to both sides of the unit and cannot terminate in attic spaces.

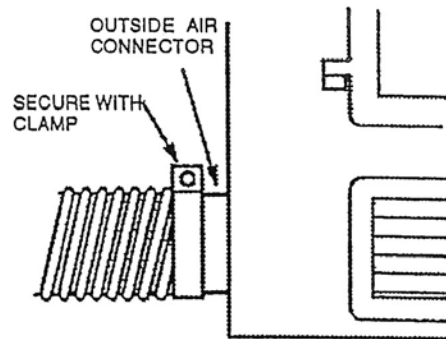
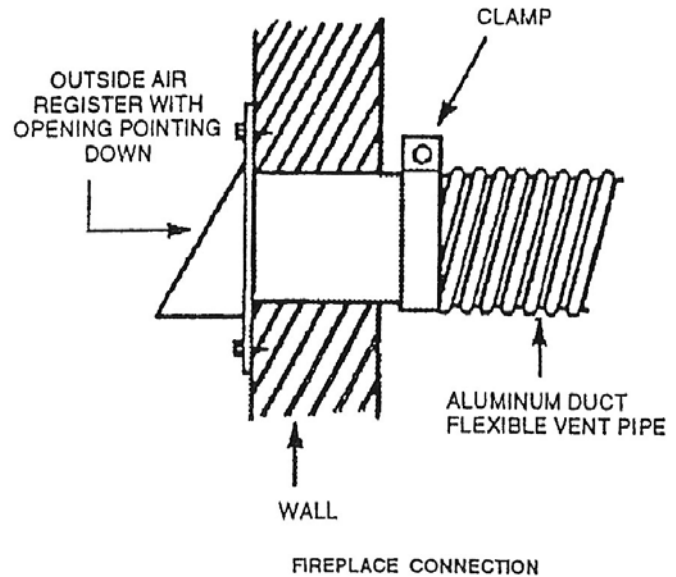

CAUTION!
IMPROPER INSTALLATION OF THE AIR INLET DUCT CAN STARVE OTHER FUEL BURNING APPLIANCES OF COMBUSTION, VENTILATION, AND DILUTION AIR AS A RESULT OF FIREPLACE OPERATION.

8" WARM AIR OUTLETS

The two 8" heat duct outlets at the unit top are blocked off during manufacturing so the heat exits the fixed-open permanent grill at the unit front. If the 8" heat ducts are installed, however, they cannot be blocked or have closeable dampers at the heat register outlet.

An exception to this would be the self-closing dampers which are installed when using the booster fans for extended duct runs over head. Their closure would only occur in isolated instances, if at all.

HOT AIR DUCT INSTALLATION

The BuckMaster Fireplace can be used to heat a single room or an entire house. The diagrams on this and the following three pages show approved duct configuration.

- 1) SAME ROOM WITH DUCT OPTION
United States and Canada (WIRING OPTION A)

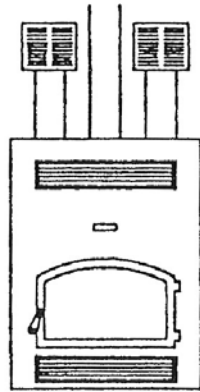

- 2) SAME ROOM AND SECOND ROOM
United States and Canada (WIRING OPTION A)

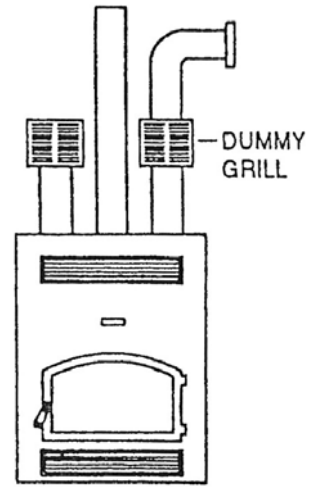

- 3) CENTRAL HEATING
United States and Canada (See complete layout on following page.)

(WIRING OPTION B,C or D)

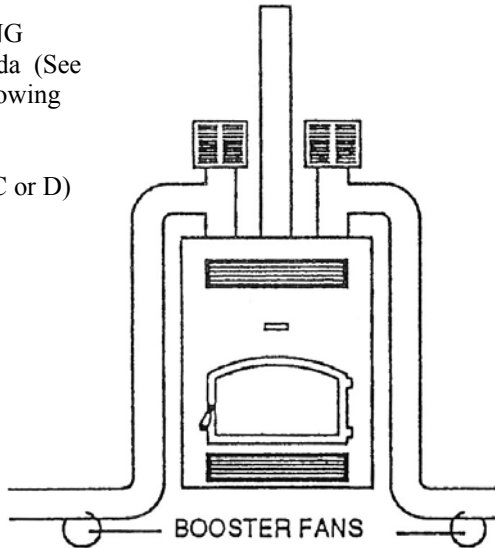

- 4) TWO ADJACENT ROOMS
United States Only (WIRING OPTION B or D)

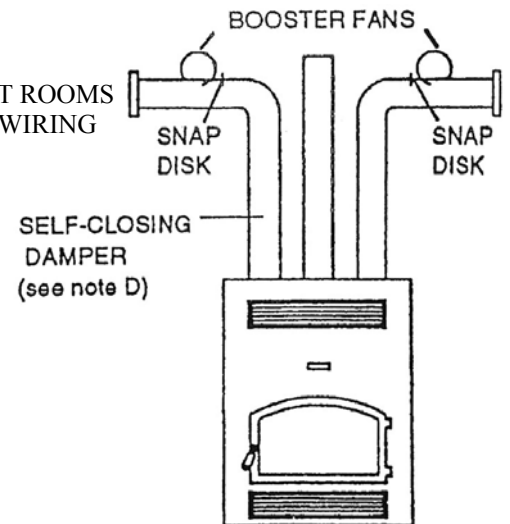

- 5) BASEMENT, SAME ROOM AND SECOND ROOM
United States Only (WIRING OPTION B)

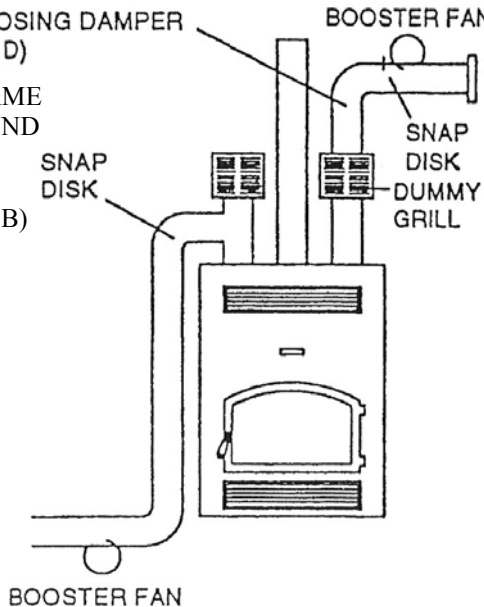

NOTES:

- In installations where ductwork is run downward, one standard hot air vent must also open into the fireplace room.
- Booster fans must not be enclosed with a chase.
- Booster fans on upward ductwork must be equipped with snap disk, heat sensitive switches. Booster fans on downward ductwork may be equipped with snap disk, heat sensitive switches or an on/off switch.
- All hot air ductwork must be 8" diameter B-Vent through the initial wall or ceiling penetration. Single wall pipe may then be used providing booster fans and self closing dampers are installed on upward ducting.
- See wiring section for detailed electrical requirements.
- B-Vent will retain heat much better than single wall pipe for longer runs.
- Cut hole in outer skin of B-Vent to install snap disk.

TYPICAL DUCTWORK LAYOUT FOR CENTRAL HEATING

Approved for United States and Canada

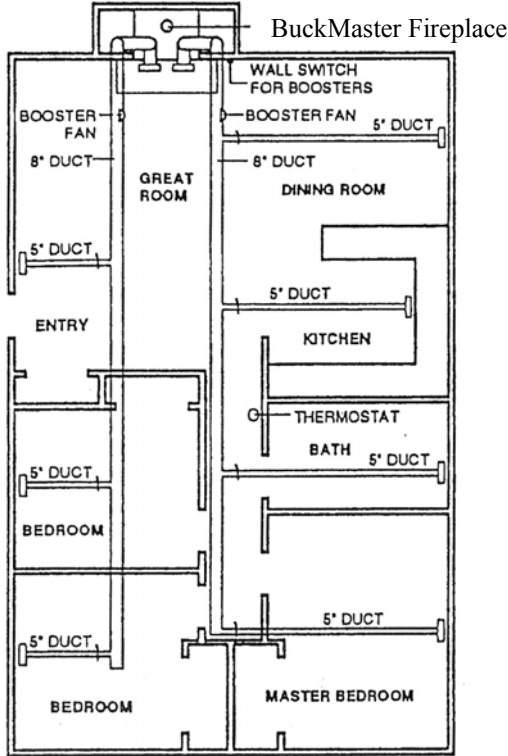

NOTE:
 DUCT WORK MAY BE RUN OVERHEAD OR BELOW FLOOR FOR UNITED STATES - BELOW FLOOR ONLY FOR CANADA.

When running ductwork down, standard hot air registers must also open into room with fireplace.



EXAMPLE:
 1200 SQ. FT. HOME

CLEARANCE CONSIDERATIONS WHEN INSTALLING HOT AIR DUCTWORK

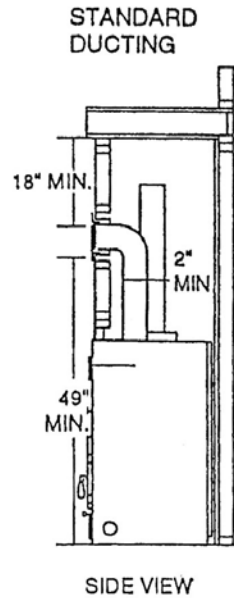
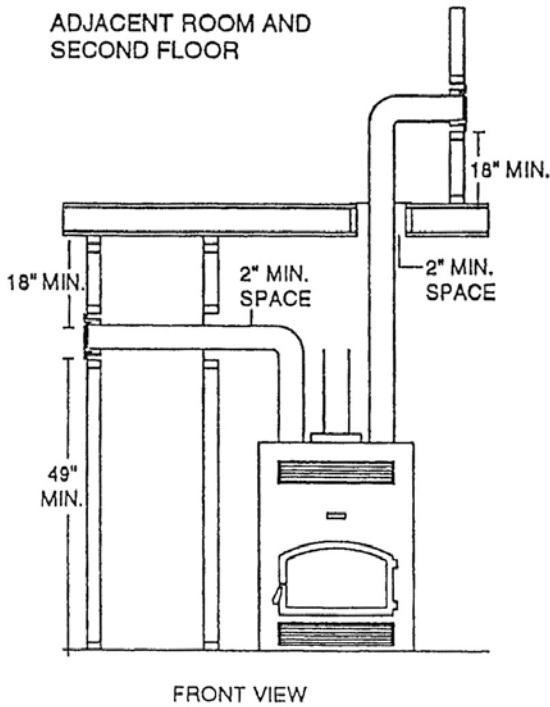

NOTE: All hot air ductwork must be 8" diameter B-Vent through the initial wall or ceiling penetration. Single wall pipe may then be used providing booster fans and self-closing dampers are installed on upward ducting.

CENTRAL HEATING DUCT SYSTEM CLEARANCES

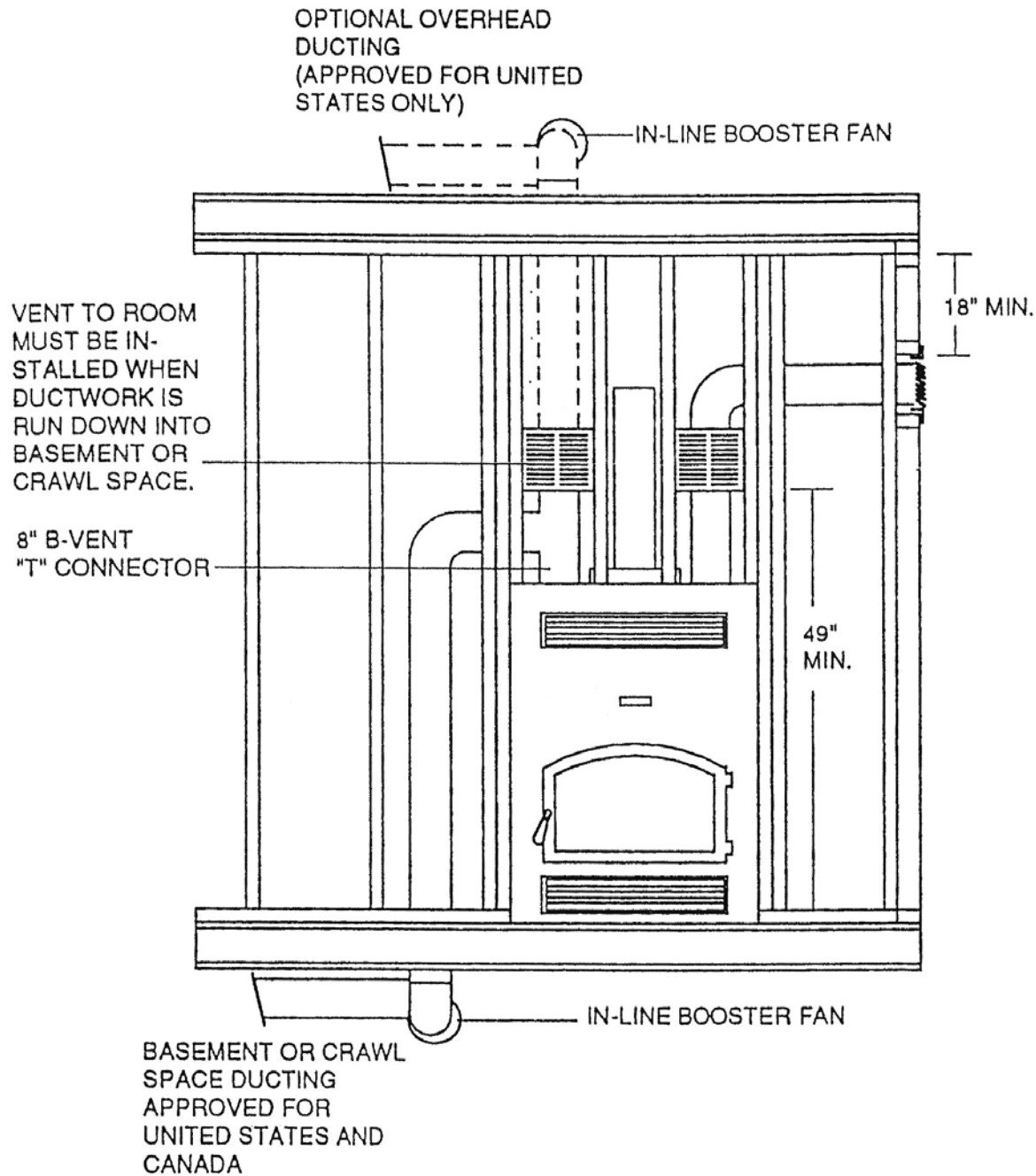

All hot air ductwork must be 8" diameter B-Vent through the initial wall or ceiling penetration. Single wall pipe may then be used providing booster fans and backdraft dampers are installed on upward ducting.

2" clearance to combustibles must be maintained around the hot air ductwork.

NOTE: When ducting down, attach a 90° elbow to the top of "T" connector for installation of room hot air register.

This is essential to dissipate heat in the event of fan failure.

Attach 90° elbow to side of "T" to run ducting to basement or crawl space.

OPTIONAL HOT AIR DUCT KIT AND 10" x 10" GRILL KIT

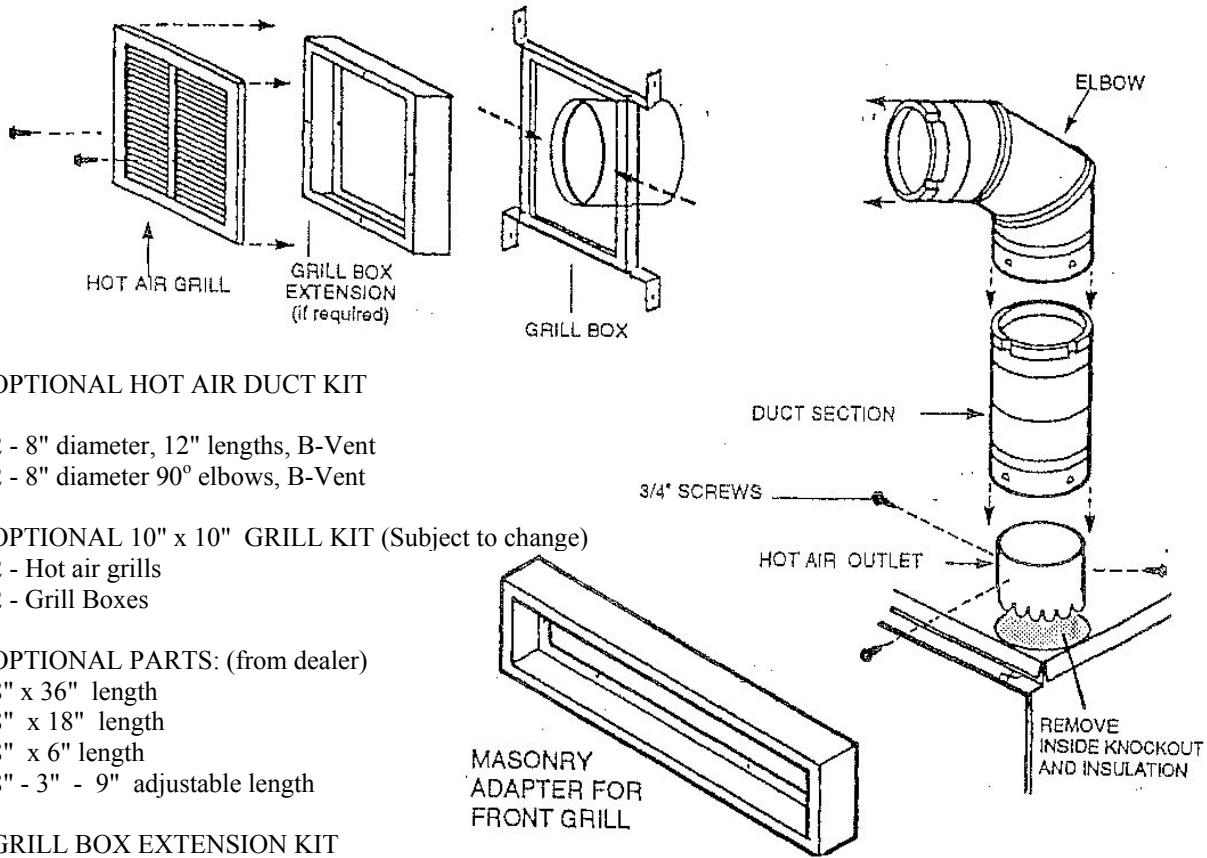

OPTIONAL HOT AIR DUCT KIT

- 2 - 8" diameter, 12" lengths, B-Vent
- 2 - 8" diameter 90° elbows, B-Vent

OPTIONAL 10" x 10" GRILL KIT (Subject to change)

- 2 - Hot air grills
- 2 - Grill Boxes

OPTIONAL PARTS: (from dealer)

- 8" x 36" length
- 8" x 18" length
- 8" x 6" length
- 8" - 3" - 9" adjustable length

GRILL BOX EXTENSION KIT

- 2 - Grill Box Extensions

Cut out in drywall for grill box is 11 1/8" square.

HOT AIR DUCT INSTALLATION

The hot air outlets may be vented into the same room as the fireplace or to an adjacent room or second floor. When going through a combustible wall or floor, a radiation shield must be installed in the wall. The required hole size is 13" x 13" for studs and flooring.

CAUTIONS:

1. Do not install heat registers below the level of the two hot air outlets on the top of the fireplace.
2. Do not tie the ducts into a central heating system.
3. All hot air ductwork must be 8" diameter B-Vent through the initial wall or ceiling penetration. Single wall pipe may then be used providing booster fans and backdraft dampers are installed on upward ducting.

4. Use only outlet registers approved for this unit. Other registers may restrict air flow causing overheating.
5. Do not run hot air ducts for a distance greater than 10' unless system is equipped with booster fans. (See page 6.)
6. Maintain a 2" minimum clearance from ducts to combustibles.

NOTE: The grills must exit at least 18" away from the ceiling and 16" from the side walls.

2" from sidewall if duct booster fans are installed with snap disks.

FLUSH FIREPLACE INSTRUCTIONS WHEN INSTALLED WITH 8" DUCT KIT

1. Fit a 90° elbow to the top of each duct section. Push down firmly to snap lock them together.
2. Attach the duct sections to the hot air outlets on top of the fireplace. Fasten them in place by screwing three metal screws through the pipe and into the fireplace hot air outlets. Be sure face of each elbow is parallel to the front of the fireplace.
3. The hot air outlet registers are in two parts (grill and grill box). Put the grills aside for now. Slide grill boxes over end of 90° elbows. Using a straightedge, check that front of grill boxes are even with front of fireplace. Secure each grill box to elbows with two sheet metal screws.

RECESSED FIREPLACE INSTALLATIONS WHEN INSTALLED WITH 8" DUCT KIT

When the hot air ducts will pass through a masonry surround built around the fireplace, a grill box extension kit must be used to make the face of the hot air registers flush with the brick or stone. Proceed as follows:

1. Fit a 90° elbow to the top of each duct section. Push down firmly to snap-lock them together.
2. Attach the duct sections to the hot air outlets on top of the fireplace. Fasten them in place by screwing three metal screws through the pipe and into the fireplace hot air outlets. Be sure the face of each elbow is parallel to the front of the fireplace.
3. Screw grill box extensions onto standard grill boxes using four metal screws. Slide grill box assemblies over end of 90° elbows and adjust so face of grill boxes will be flush with finished brick or stone wall. Use two sheet metal screws to secure each grill box assembly to the 90° elbows.
4. Slide 5 1/4" round duct extensions over inner grill box duct collar.

If you have designed your masonry surround to extend down over the face of the fireplace, you must also add a masonry adapter for the front grill. An optional way to deal with the front grill is to entirely remove it and construct a soldier course of bricks over the opening. (See finishing details on page 13.) Depending on the amount of overlap it may also be necessary to add an extension tube for the temperature probe access port and replace the standard by-pass handle with an extended version. (Consult your dealer.)

INSTALLING EXTENDED BY-PASS ROD AND ACCESS PORT EXTENSION

1. Pull off top grill and remove set screw from by-pass rod retaining collar.
2. Pull out existing rod, insert extended rod and replace set screw. If necessary, access door on by-pass chamber may be removed to facilitate alignment of rod.

NOTE: When bricking in the access port extension sleeve (smaller one) and the extended by-pass rod sleeve, make sure they are aligned properly.

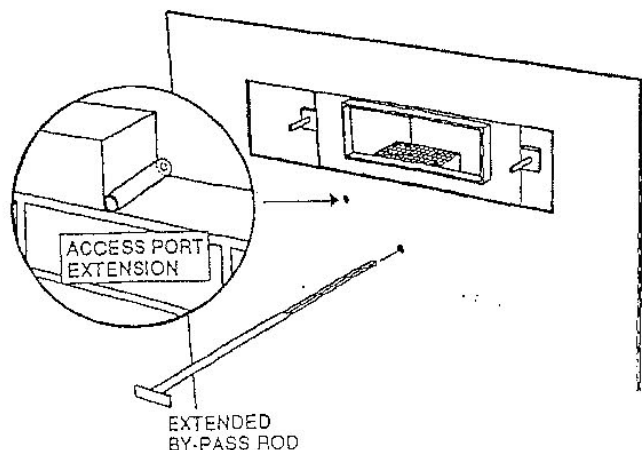
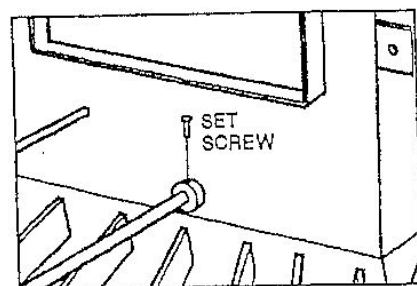
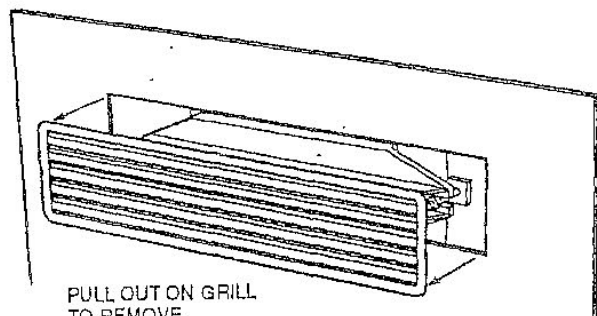

INSTALLING MASONRY ADAPTER

1. With the top grill removed, position the masonry adapter over the opening and mark the position of the six holes in the adapter's rear flange.
2. Drill holes into the face of the fireplace and attach the adapter.
3. When finishing details are complete push grill into adapter.

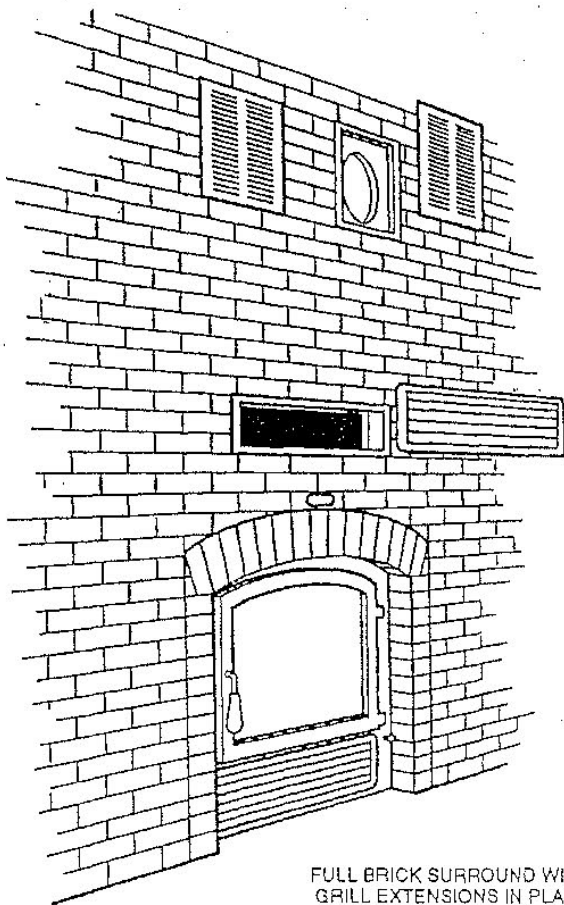
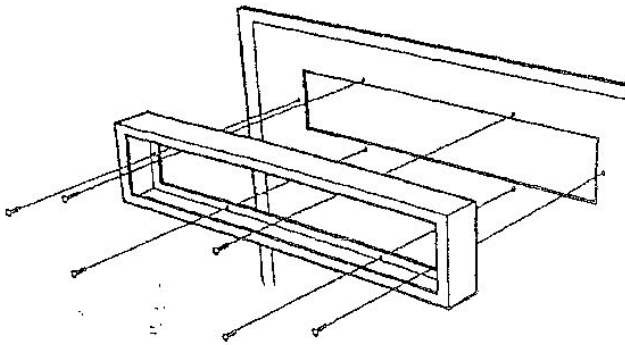

FULL BRICK SURROUND WITH GRILL EXTENSIONS IN PLACE

FRAMING-IN AND FINISHING INSTALLATION

The BuckMaster fireplace has been designed so it can be framed-in using standard combustible building materials without providing additional fireproofing or air spaces.

PRECAUTIONS

Do not place unit directly against an exposed vapor barrier. A vapor barrier should be covered with sheet rock or similar material.

When installing unit, be sure it is completely wired during the rough framing stage. (See pages 17-18.)

FRAMING

1. Frame the fireplace using 2" x 4" or heavier lumber. Use double studs on either side of the fireplace. The header above the front black facing must be 2" x 4" set on edge.
2. Frame-in vertical sides of grill boxes with 2" x 4"s (when applicable) and secure boxes with corner nailing strips. See illustrations for general framing layout.
3. Combustible wall material must be installed flush with the fireplace facing. It may not project out in front of the fireplace.
4. When facing the fireplace with brick, etc., the material must not overlap the front of the unit more than 2" on the sides to allow proper operation of the doors.
5. When the front finish is complete, install the hot air outlet grills with screws provided. The grills should point downward to direct the hot air toward the floor.

WARNINGS

1. Do not build in the area directly above the fireplace. This area must remain empty.
2. The header should rest on top of the metal spacer. Do not alter the spacers or notch the header to fit around them.
3. Do not put wood or combustibles directly on fireplace.
4. Do not block the rectangular air inlet or outlet, as this will cause the fireplace to overheat. If installing a brick soldier course as shown, the top metal grill must first be removed.
5. A wood mantel, if installed, must be at least 49" above the base of the fireplace.
6. Do not use a fireplace insert or other products not specified for use with this furnace.

FIREPLACE DIMENSIONS (in inches)

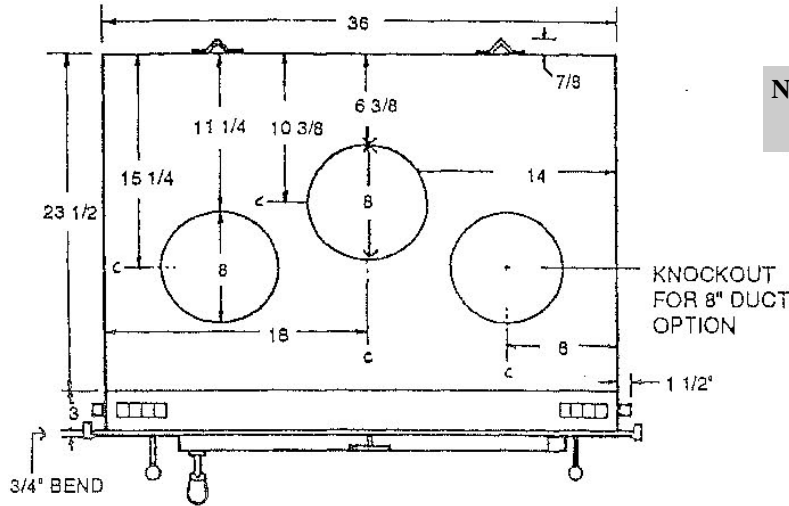

**NOTE: Rough opening size:
38 1/2" WIDE x 52" HIGH**

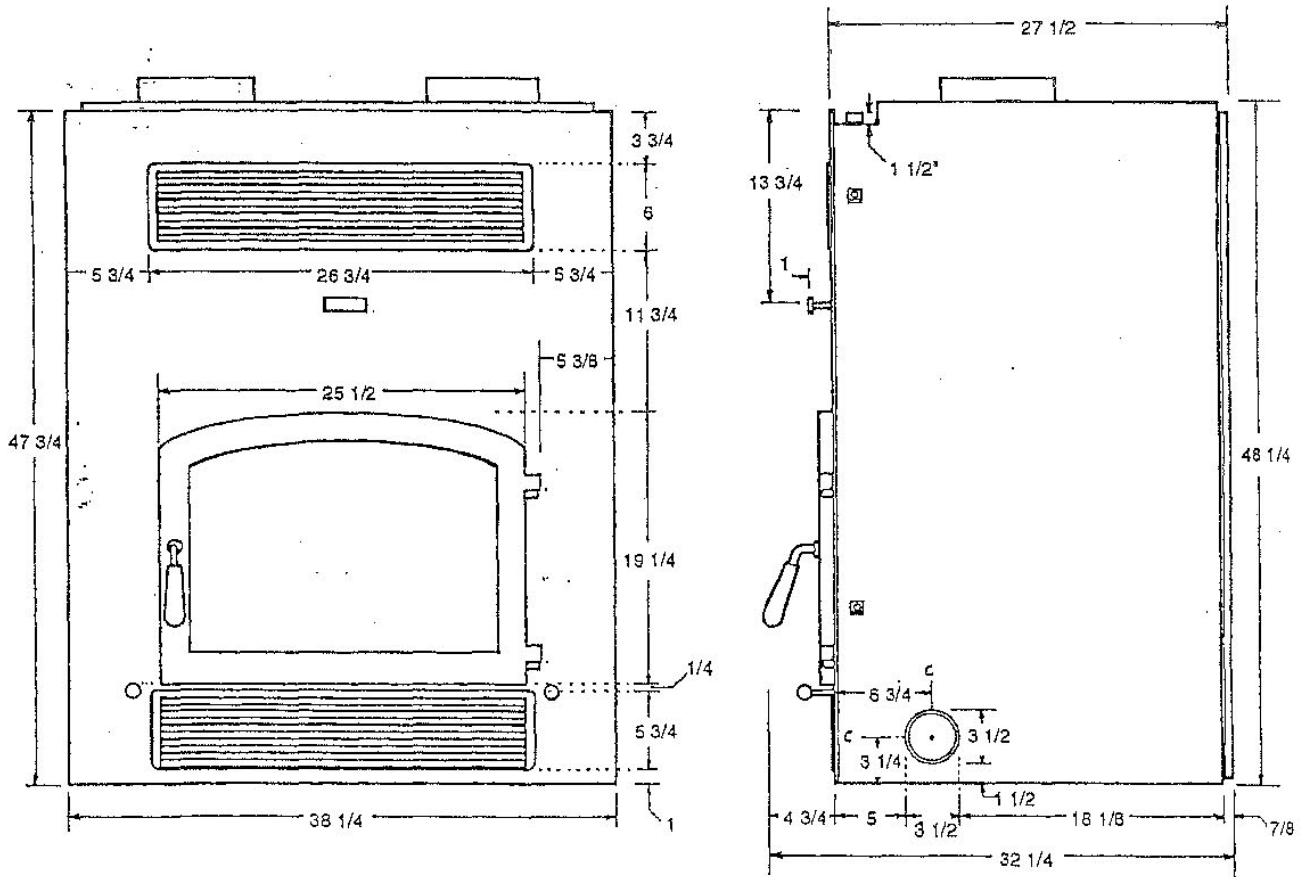

NON-COMBUSTIBLE FACING CUT-OUT DIMENSIONS

Required for tile or marble facing

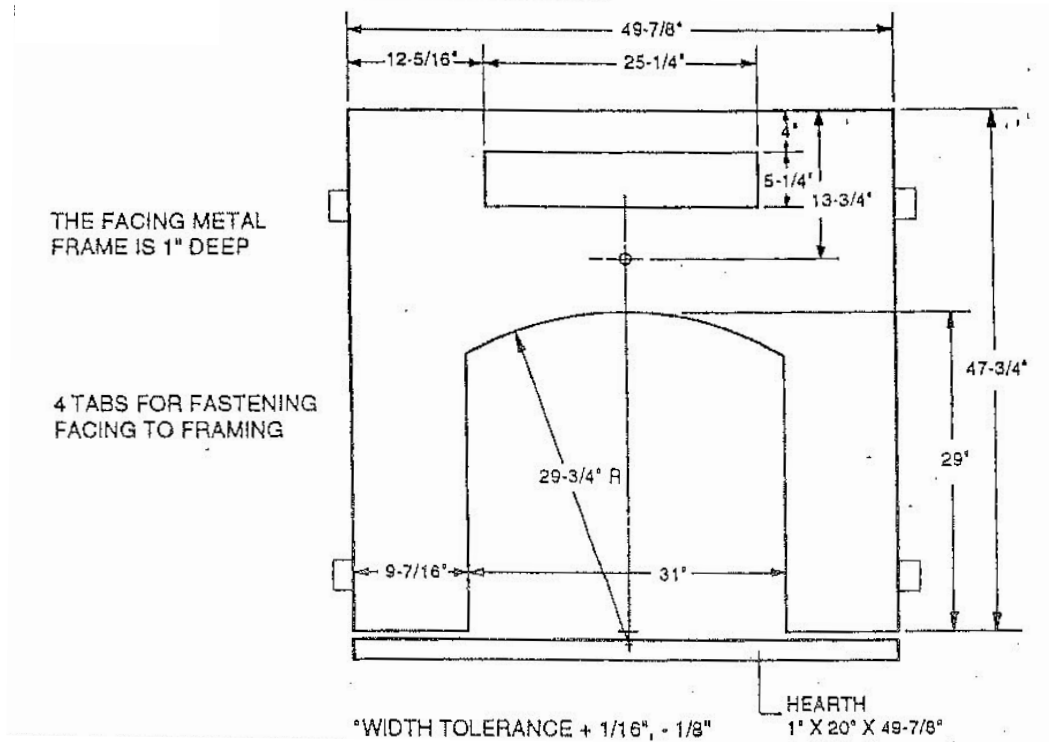

SET-BACK FOR FACING OPTIONS

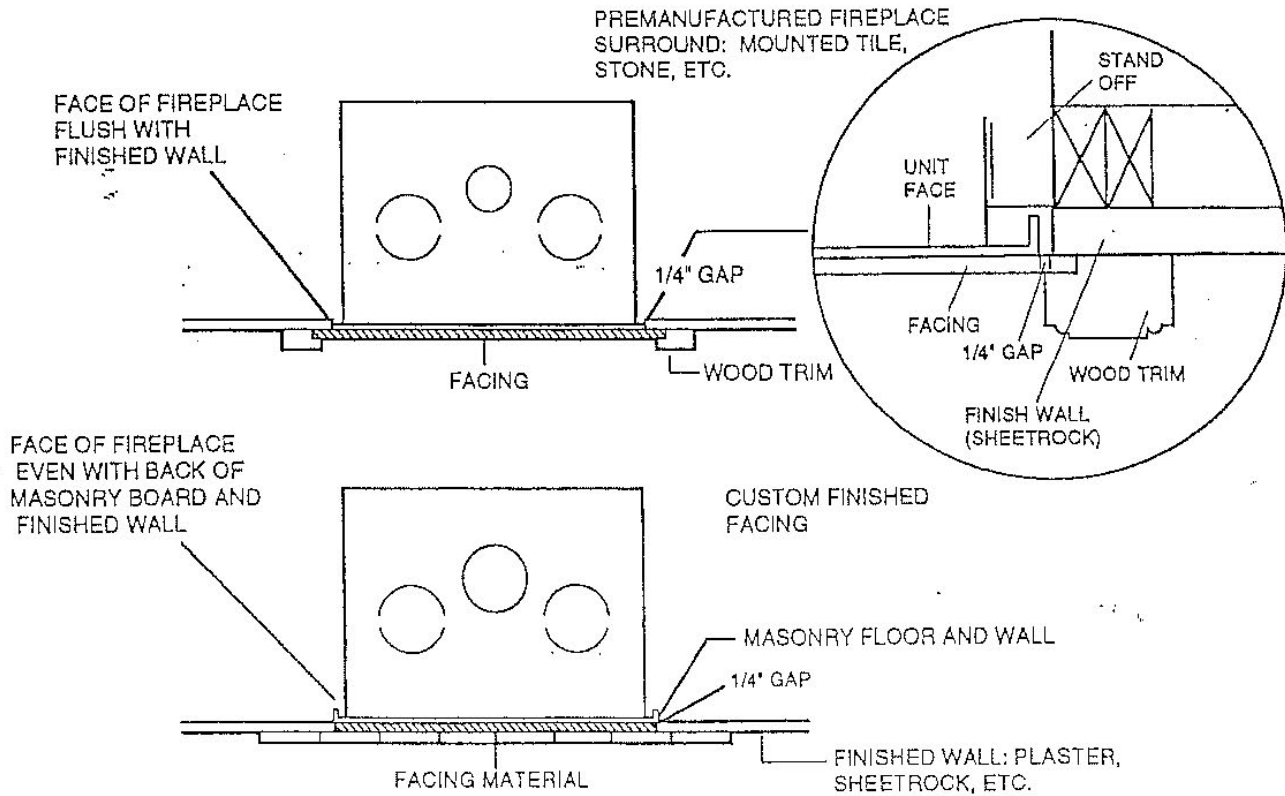

ROUGH OPENING DIMENSIONS

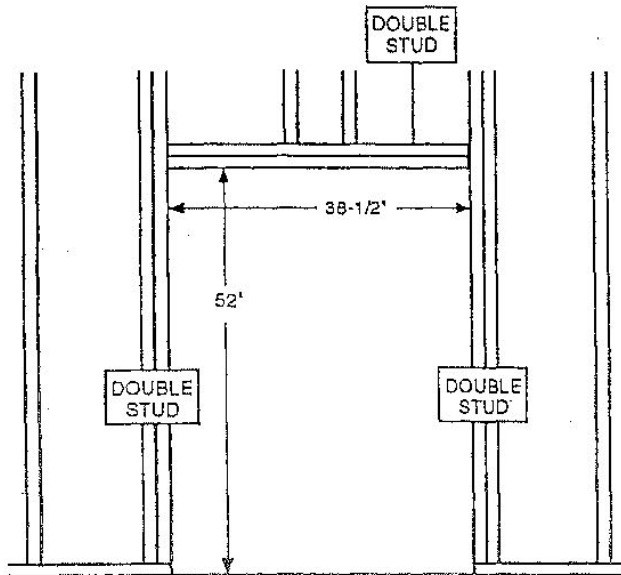

ROUGH FRAMED FLOOR LEVEL INSTALLATION SHOWN WITH OPTIONAL 10" x 10" GRILL KIT

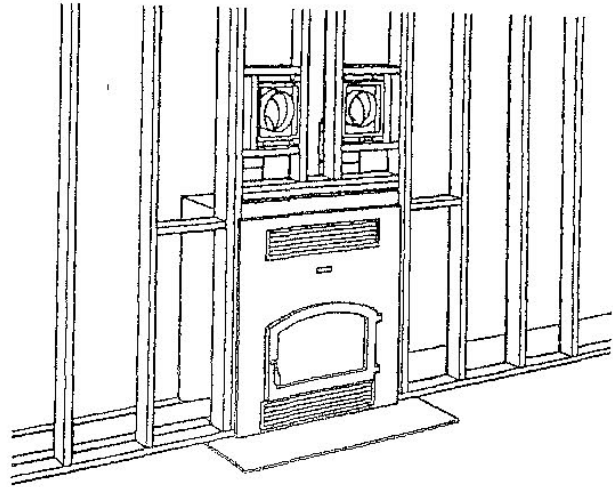

HEADER DETAIL

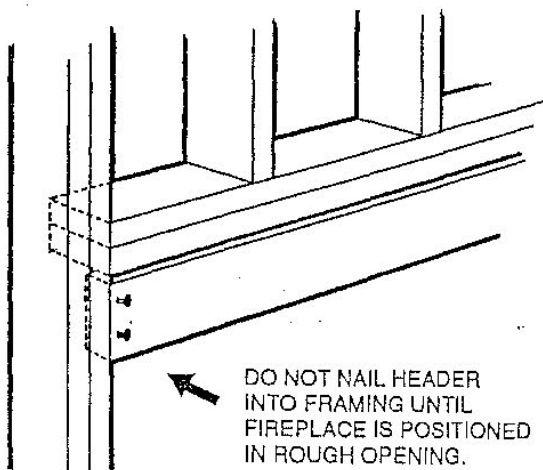

ROUGH FRAMED RAISED INSTALLATION SHOWN WITH OPTIONAL 10" x 10" GRILL KIT

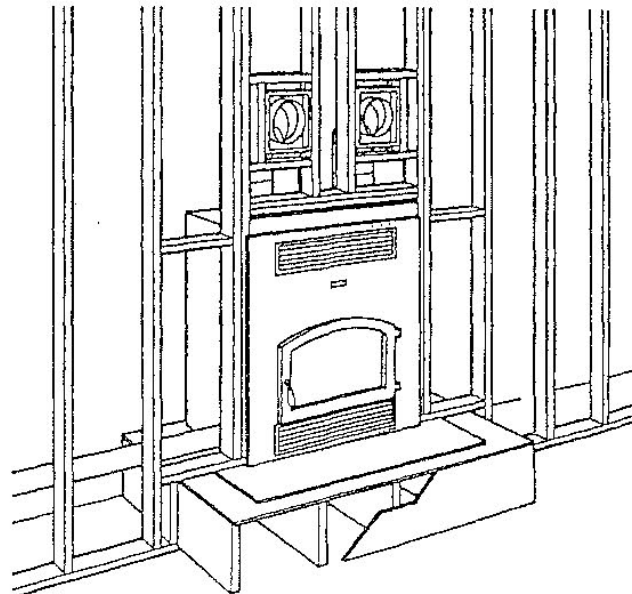

FINISHING DETAILS AND OPTIONS

PARTIALLY OVERLAPPED NON-COMBUSTIBLE FACING

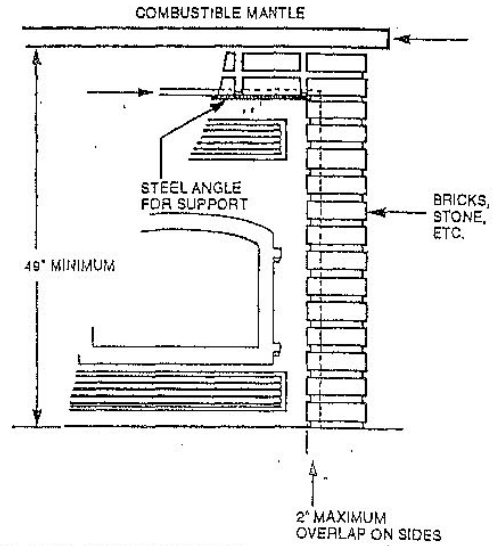
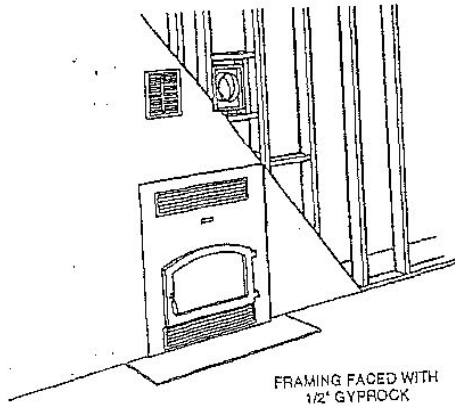

SOLDIER COURSE BRICK

Remove top grill. Leave 2" minimum open space between vertical bricks. Total open area in front of grill opening must be at least 90 square inches.

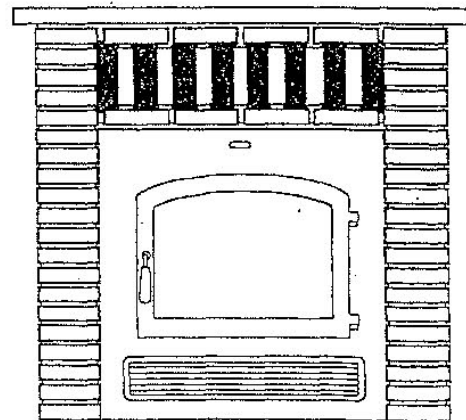
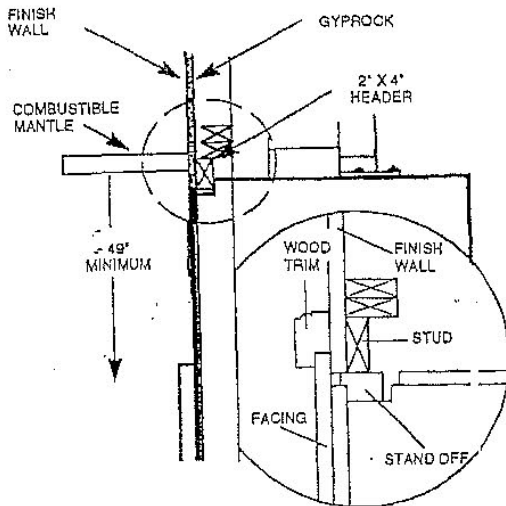

FINISHING HEARTH:

A non-combustible hearth (e.g. ceramic tiles, stone, bricks, etc.) must extend 24" in front of and 8" beyond the sides of the fuel loading door. This hearth extension must be placed on non-combustible flooring. If this unit is to be installed with a raised hearth, a non-combustible hearth must extend 16" in front of and 8" beyond the sides of the fuel loading door.

STANDARD FORCED AIR FAN

WIRING OF FAN SHOULD BE PERFORMED BY A QUALIFIED ELECTRICIAN.

The forced air fan comes factory installed and includes the prewired motor with fan blade and mounting hardware.

The directions below describes how to wire the fan for a standard duct system equipped with booster fans and/or snap disks. Refer to the Wiring Diagrams on pages 19 and 20 for further instructions.

1. Mount a 2" x 4" electrical box on the framing near the fireplace for installing a switch to control the fan kit.
2. On the left side of the fireplace closest to the switch location, feed a length of flexible conduit through the 7/8" hole in the sidewall of the fireplace.
3. The conduit must have three conductors: hot, neutral, and ground.
4. Open the electrical box on the fan motor which is located on the left side of the power conduit.
5. Run power conduit to switch box. Secure with BMX connector (not supplied).
6. Run grounded electrical cable from a new or existing 15 AMP circuit to the switch box and connect wires and switch as shown in wiring schematic.

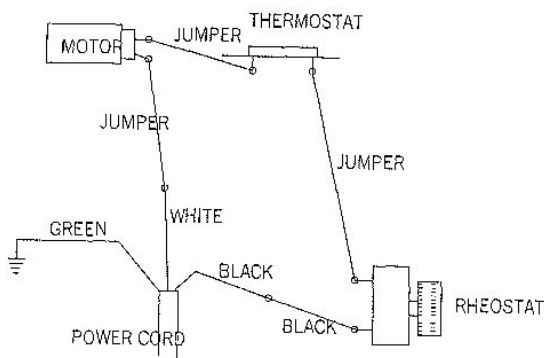
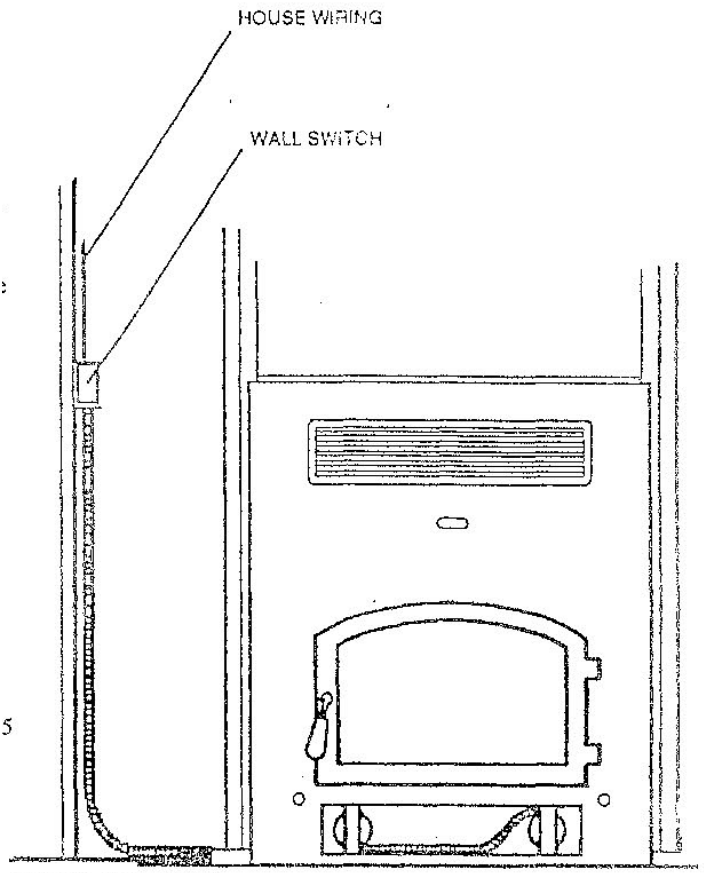

NOTE: Installation and repair should be done by a qualified service person. This heater should be inspected before use and at least annually by a qualified service person. More frequent cleaning may be required due to excessive lint from carpeting, bedding material, pet hair, etc. It is imperative that control compartments and circulating air passageways of the heater be kept clean.

NOTE: If any of the original wire as supplied with the appliance must be replaced, it must be replaced with type 16 ga., 105° C. rating wire or its equivalent.

DOOR HANDLE INSTALLATION

1. Screw wooden handle onto shank and insert into door.
2. Secure with locking nut.
3. Slide on washer and latch cam and secure with locking nut.

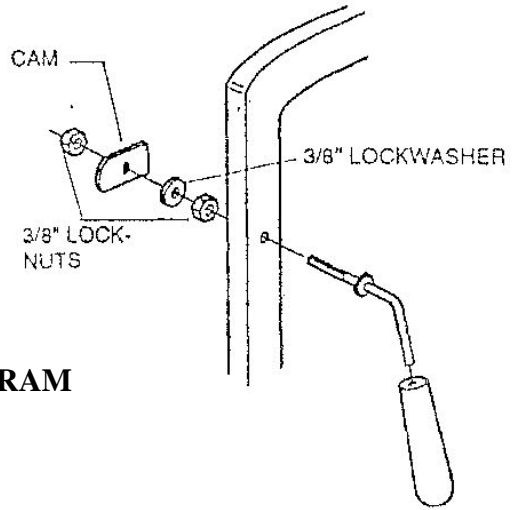

STANDARD WIRING DIAGRAM WITH WALL SWITCH

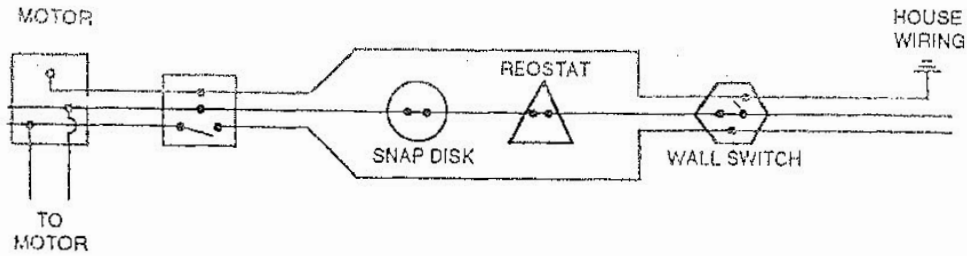

OPTIONAL WIRING

Refer to configurations shown on page 8.

STANDARD FANS WITH BOOSTERS

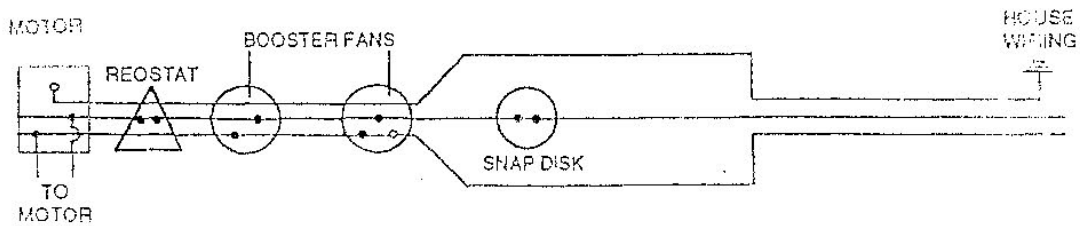

C. STANDARD FANS WITH BOOSTERS ON SEPARATE WALL SWITCH

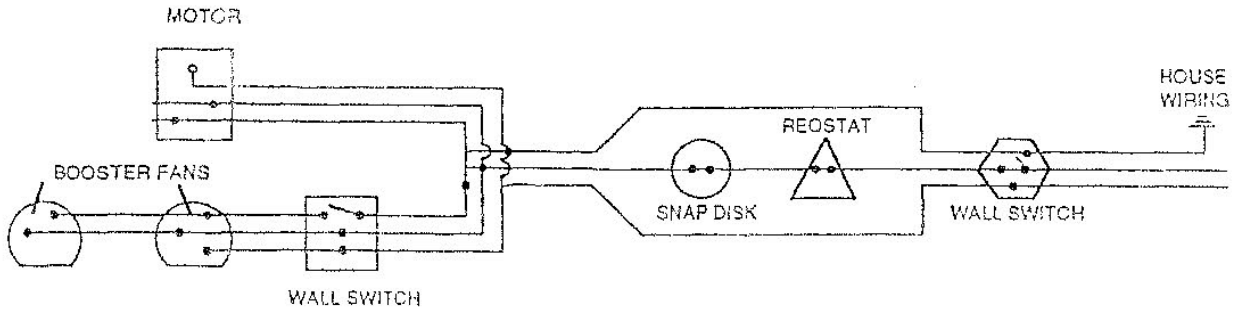

D. STANDARD FANS WITH BOOSTERS ON THERMOSTAT

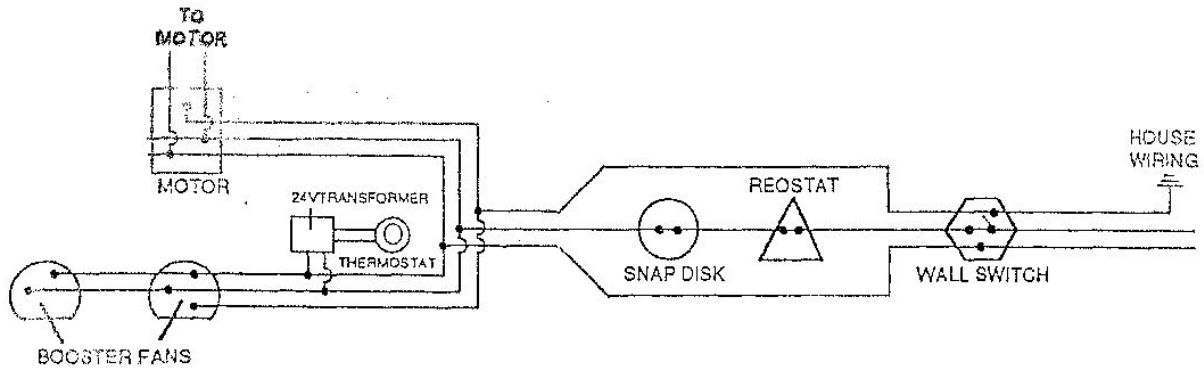

OPERATION

The BuckMaster fireplace is designed for burning clean, clear wood only. Well dried hardwoods are recommended for more even combustion, heating and reduced creosote formation. Small to medium, brisk fires are recommended. Extremely hot fires may cause discoloration of gold doors and are not required to achieve maximum efficiency.

Do not overload the fireplace to increase burning times. If you wish to hold a fire overnight, first close draft controls tight, then pull approximately 1/4". This will slow the fire, and leave a bed of hot embers that will facilitate relighting in the morning. Slow combustion fires produce more creosote which will condense on the glass doors and chimney, requiring more frequent cleaning.

NEVER BURN COLORED PAPER, PAINTED WOOD, WOOD WITH NAILS, ETC. THESE MATERIALS CONTAIN COMPOUNDS THAT WILL DAMAGE THE UNIT'S CATALYTIC COMBUSTOR.

**WARNING
DO NOT USE A FIREPLACE INSERT OR OTHER PRODUCTS NOT SPECIFIED FOR USE WITH THIS FIREPLACE**

STARTING A FIRE:

1. Pull out the two slide draft controls so they are fully open.
2. Open the by-pass damper by giving the handle at the top center of the unit a 1/4 turn to the left.

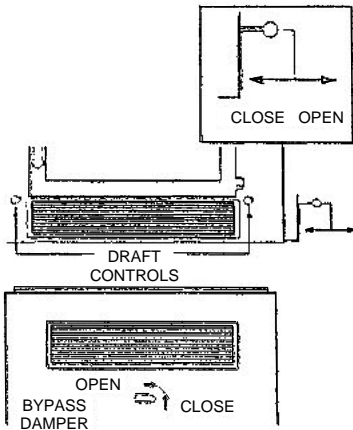

3. Place a few sheets of crumpled newspaper and some small pieces of kindling wood directly on the firebrick. Do not use additional grates or irons. Ignite the paper. Do not use flammable fluids to start the fire.
4. Once fire is established, add larger pieces of dried natural seasoned hard wood and close fireplace doors. **KEEP WOOD BEHIND PERMANENT LOG STOP AND DO NOT LOAD WOOD ABOVE HEIGHT OF FIREBRICK.**
5. Allow 15 to 20 minutes to ensure fire is burning briskly, then close by-pass damper by turning damper handle to the right.
6. If necessary, the draft controls can be adjusted inward to slow the fire and reduce the heat output.

ADDING WOOD TO EXISTING FIRE

Before adding wood, always open by-pass damper first and close after loading is completed. **NEVER OPERATE THE FIREPLACE WITH THE BY-PASS DAMPER IN THE OPEN POSITION EXCEPT DURING INITIAL FIRING AND REFUELING.**

For maximum heat production and safety, the fireplace should **ALWAYS** be operated with the door completely closed

CAUTION: Never remove ashes from heater with blower running.

ASH PAN AND ASH REMOVAL

To remove ashes from the firebox, pull the grate slide plate to the front with a poker, etc.

Push the ashes through the opening, into the ash pan. When the ash pan is approximately two thirds full, remove and empty.

IMPORTANT: Be sure to close slide plate after cleaning.

CAUTION: Ash pan may be hot, use care in handling.

Ashes should be placed in a metal container with a tight fitting lid. Keep the container on a non-combustible floor in a garage or outdoors, since ashes may remain hot for days and give off toxic fumes. Ensure that ashes are completely cool before final disposal. Leaving a small amount of ash in the pan and on the fireplace grate will help protect the metal from excessive heat and enhance combustion efficiency.

DO NOT operate the fireplace without the ash pan in place. Also, the ash pan must be completely closed during operation to prevent excessive draft which can cause overheating.

CARE AND MAINTENANCE

CAUTION! DO NOT CLEAN WHILE FIREPLACE IS HOT.

1. Check the fiber rope gasket around the door periodically to ensure a tight fit. Replace gaskets if they are not providing a tight seal.

2. Clean the glass doors. The BuckMaster incorporates an air wash system that helps keep the glass free of creosote.

If the glass becomes dirty as a result of frequent slow burning fires, build and maintain a brisk fire. This will burn off creosote deposits. The glass may also be cleaned with a hot water/soap solution. Do not use abrasive cleansers or pads on the glass.

If the glass is ever broken it must be replaced with original equipment glass only. Consult your fireplace dealer or the manufacturer. Do not replace with tempered or standard glass. **DO NOT OPERATE THIS FIREPLACE IF GLASS IS BROKEN OR MISSING.**

- A. Ensure fireplace is cool.
- B. Open door and lift door frame up to disengage hinge pins.
- C. Place door frame face down on a flat surface.
- D. Unscrew glass retaining clips along inside edge of door frame.
- E. Lift glass straight up, out of retaining channels. If glass is broken, use care to avoid sharp edges. Note that gasket on glass faces front of unit.
- F. Insert new glass, ensuring gasket is properly seated.
- G. Reinstall glass retaining clips.
- H. Rehang door frame on hinges.

3. Door frame - The gold plated frame should be cleaned with appropriate metal cleaner. Do not use steel wool or other abrasives.
4. Creosote - Formation and Need for Removal: When wood is burned slowly, it produces tar and other organic vapors which combine with expelled moisture to form creosote. The creosote vapor condenses in a relatively cool chimney flue of a slow burning fire. As a result, creosote residue accumulates on the flue lining. When ignited, the creosote makes an extremely hot fire.

The chimney connector and chimney should be inspected at least once every month during the heating season to determine if a creosote build-up has occurred. If creosote has accumulated, it should be removed to reduce risk of a chimney fire. Your dealer can recommend a qualified chimney sweep or provide you with the proper tools to do it yourself. Use only brushes that are designed for your type of chimney.

After each cleaning, check catalytic combustor to be sure it is free of creosote or other particles which may have fallen on it. A plugged combustor will cause the fireplace to smoke.

CATALYST EQUIPPED

This wood heater contains a catalytic combustor, which needs periodic inspection and replacement for proper operation. It is against the law to operate this wood heater in a manner inconsistent with operating instructions in this manual or if the catalytic element is deactivated or removed.

CATALYST WARRANTY

The combustor supplied with this heater is a 3" x 6" Applied Ceramic catalytic combustor with 16 cells per sq. in. Consult the catalytic combustor warranty also supplied with this heater. All warranty claims should be addressed to:

Applied Ceramics
Customer Service Department
P.O. Box 29664
Atlanta, GA 30359
770-448-6888

See enclosed catalyst warranty for instructions. New Buck Corporation does not handle catalyst replacements. Customer can order direct form Applied Ceramics.

PROPER FUEL SELECTION

For best results, this heater is designed to burn dried natural seasoned hard wood. Higher efficiencies and lower emissions generally result when burning air dried natural seasoned hardwoods, as compared to softwoods or to green or freshly cut hardwoods. Green or freshly cut hardwoods (wood with high moisture content) **will not** product the BTU's needed to heat your home. The result will be low temperature reading on the catalyst probe, thus low BTU output.

For peak performance, we suggest the use of natural seasoned hard wood, loading wood length way from front to rear.

NOTE: Soft woods such as pine, create more creosote, clogging of chimney, and produce a less efficient burn performance.

DO NOT BURN: trash or garbage, artificial or paper logs, cardboard, gift wrapping, treated or painted wood or any type of coal, or flammable fluids.

Burning treated wood, garbage, solvents, colored paper or trash may result in release of toxic fumes and may poison or render the catalytic combustor ineffective.

Burning coal, cardboard, or loose paper can produce soot, or large flakes of char or fly ash that can coat the combustor, causing smoke spillage into the room and rendering the combustor ineffective. (Not covered under warranty.)

CATALYTIC COMBUSTOR REPLACEMENT

1. Ensure that fireplace is cool.
2. Remove front grill.
3. Remove cast iron access door on front of secondary heat chamber.
4. Lift out old catalytic combustor and replace with a new 3" x 6" Applied Ceramic catalytic combustor with 16 cells per sq. in. (Consult your dealer.)
5. Replace access door and front grill.

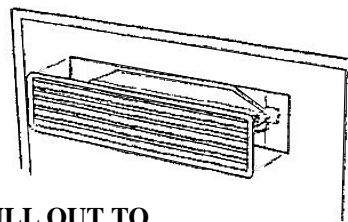

PULL OUT TO REMOVE GRILL

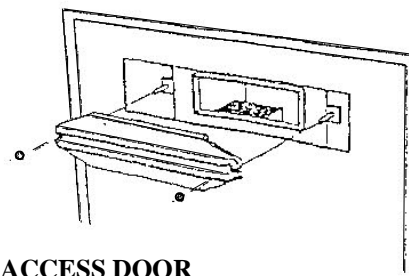

ACCESS DOOR

NOTE: If you have installed a brick solder course over the top grill, the catalytic combustor must be removed through the firebox.

1. Remove firebrick baffle and supporting angle irons.
2. Slide flame impingement shield to the right and remove.
3. Open by-pass door.
4. Reach into the firebox and raise catalytic combustor to top of secondary heat chamber.
5. Remove combustor through open by-pass door. To install new combustor, follow steps in reverse order.

INSIDE VIEW OF FIREBOX TOP

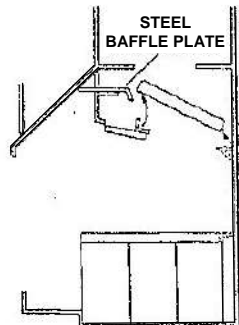
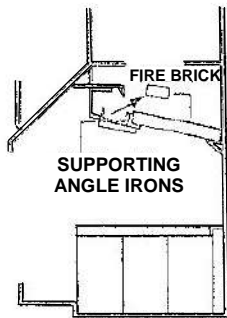
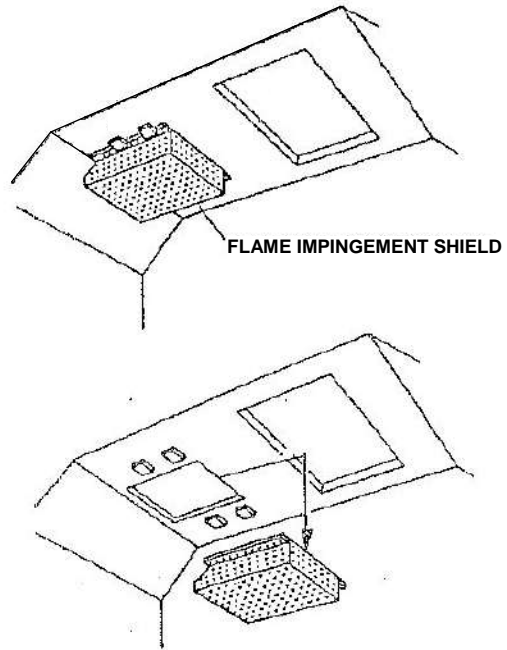

SIDE VIEW OF FIREBOX

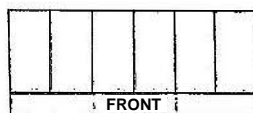
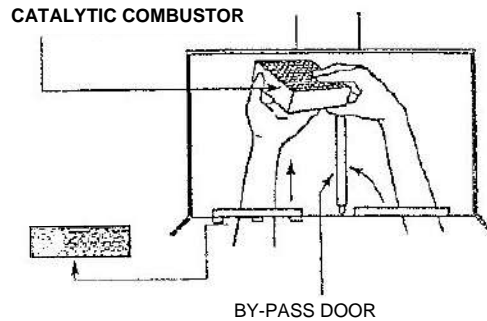

TOP VIEW FIREBRICK ARRANGEMENT

BY-PASS DOOR REPLACEMENT

All materials subjected to high temperatures will eventually breakdown. If during regular inspection of the firebox you discover a hole developing in the cast iron by-pass door it should be replaced.

1. Remove top grill and access door as explained in catalytic combustor replacement.
2. Remove set screw from by-pass rod collar and jerk on rod to free it from the by-pass door.
3. Lift out old door and replace with new one. Reinsert by-pass rod and secure with collar set screw.
4. Replace access door and top grill.

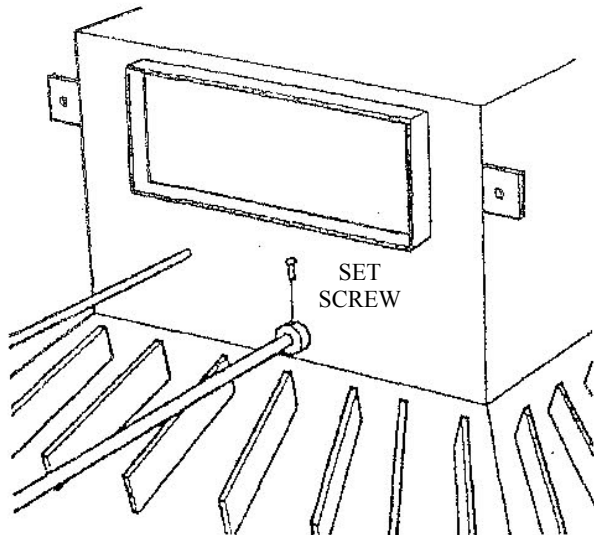

CATALYTIC
COMBUSTOR

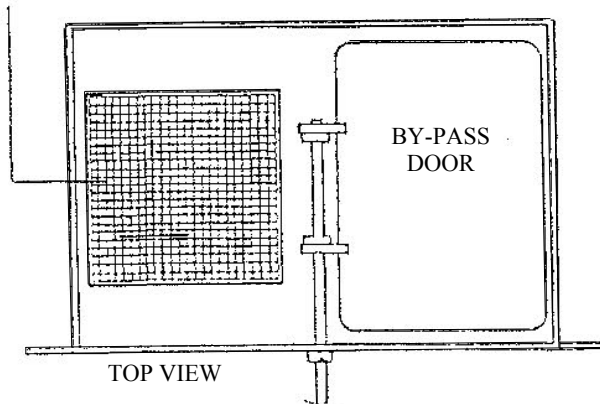

TROUBLE SHOOTING

1. Smoke Coming From Fireplace
 - A. Inadequate Combustion Air - Check that exterior air duct is not closed or blocked and that draft controls are properly set.
 - B. Exhaust Fan - An exhaust fan, particularly in a tightly build house, may pull smoke back down the chimney and into the house. Try opening a window a small amount of avoiding operating such fans when fireplace is in use.
 - C. Wet Wood - Use only properly cured woods.
 - D. Dirty or Blocked Chimney - Check and clean as necessary.
 - E. Chimney Too Short - Review chimney specifications in this manual and see that your installation conforms to them.

2. Excessive Creosote

Creosote is a dark brown and black combustion by-product. While deposits in the chimney cannot be totally eliminated, smaller, hot fires will minimize formation.

CHIMNEY FIRES

A chimney that is not regularly cleaned presents a greater risk of chimney fire. When creosote deposits are ignited, an extremely hot fire will result.

If you experience a chimney fire:

1. Close the fireplace door and close draft controls.
2. Evacuate all people from the house and notify the fire department.
3. If possible, discharge a dry chemical fire extinguisher or throw baking soda or sand on the fire inside the fireplace to control the fire. **DO NOT USE WATER.**
4. Check for smoldering or burning combustibles next to the fireplace and chimney. Also check that there are no sparks or hot embers on the roof.
5. Once the fire is out, have the complete system thoroughly checked over before using again.

PARTS LIST

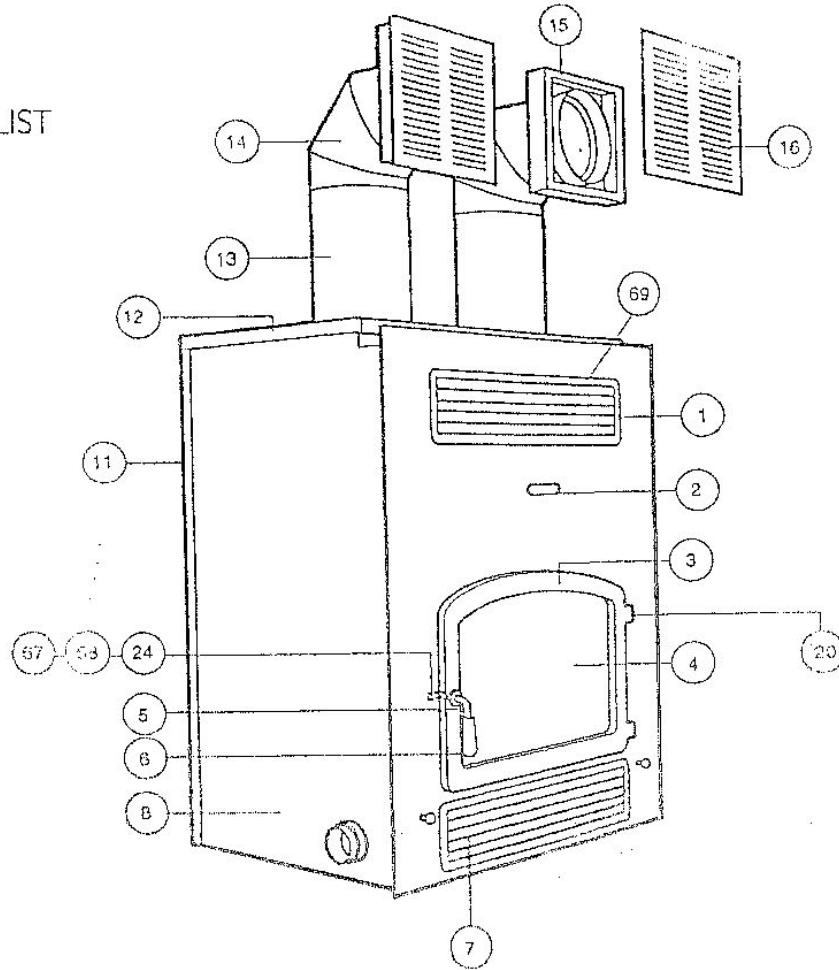

ITEM	DESCRIPTION	PART #	ITEM	DESCRIPTION	PART #
1	Top Grill	PO CL60-89787	13	Optional 8" Hot Air Duct x 12"	N/A*
2	By-pass Handle	PO CL60-89780	14	Optional 8" 90° Elbow	N/A*
3	Door (Gold)	PC CL60-23803	15	Optional Grill Box	PS CL60-24033
4	Glass	PG CL60-89672	16	Optional 10" x 10" Grill	PO CL60-86523
5	Door Handle	PO CL60-89712	20	7/32" x 1" Hinge Pin	PH 7321LSP
6	Door Handle (wood)	PO CL60-89819	24	Door Latch	PO CL60-24282
7	Ash Grill	PO CL60-89711	67	3/8" Locknut	PH 3816HNP5
8	Outer Side	PS CL60-24002	68	3/8" Lockwasher	PH 38LKWSP5
11	Outer Back	PS CL60-23998	69	Grill Clips	N/A
12	Outer Top	PS CL60-24004			

* USE COMMON 8" B-VENT PIPE

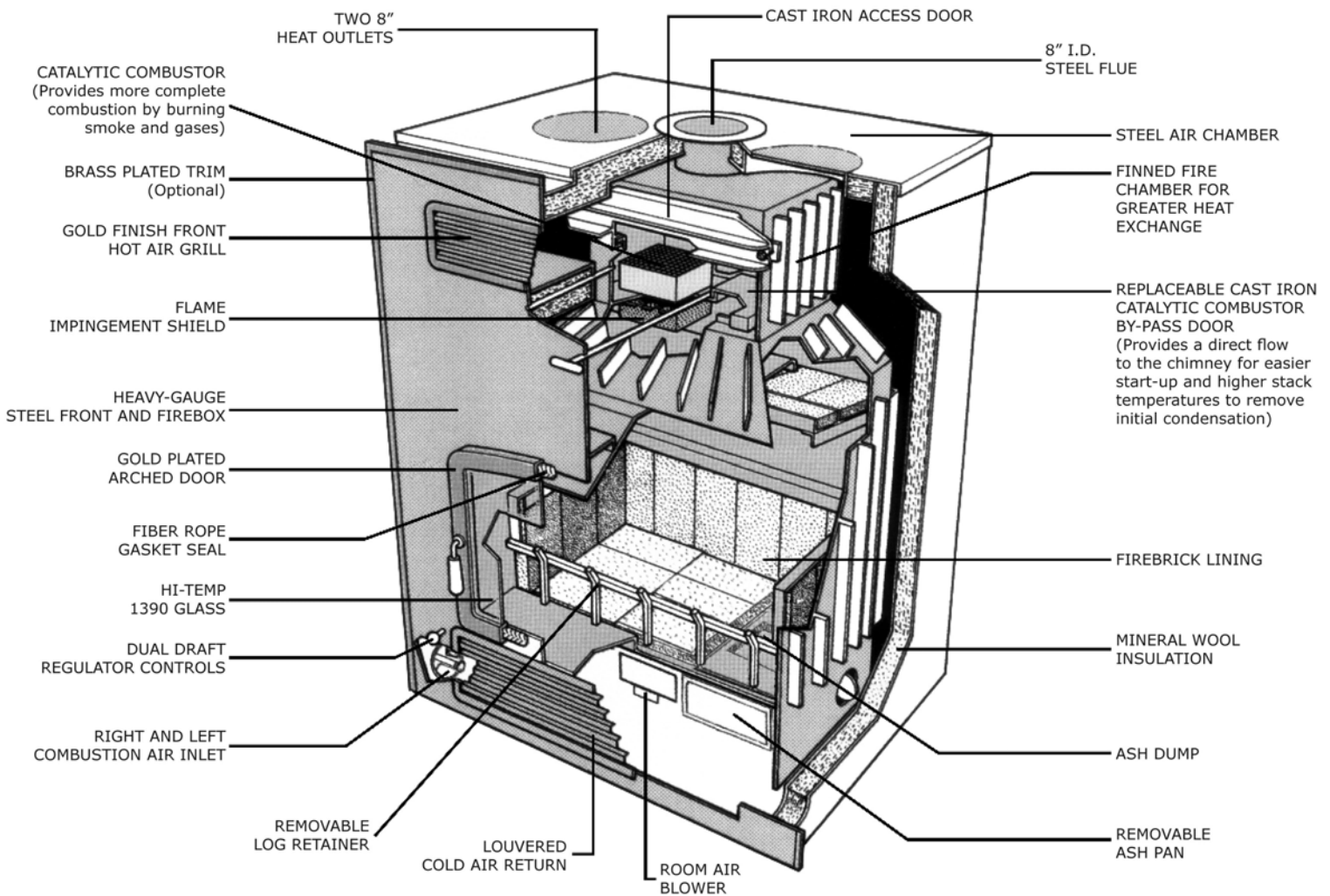

ITEM	DESCRIPTION	PART #	ITEM	DESCRIPTION	PART #
25	Inner Top	PS CL60-24160	42	Glass Rope	RP FTV125X1.00GA
26	Back Insulation	N/A	43	Door Rope	RP 7810863KRP
27	Cast Iron Access Door	PC CL60-40347	44	Glass Holders	PS CL60-24008
28	Inner Back	PS CL60-24005	45	1/4" - 20 x 3/8" Screws	N/A
29	Inner Side	PS CL60-23999	48	Front Insulation	N/A
31	Side Insulation	N/A	49	Front Air Duct	PS CL60-23996
32	Cast Iron By-pass Door	PC CL60-40346	50	Top Grill (Gold)	PO CL60-89797
33	By-pass Door Rod	PO CL60-89707	52	Outer Front	PS CL60-24060
34	3/8" x 3/8" Set Screw	N/A	53	Top Insulation	N/A
35	Catalytic Combustor	PO CL60-89786	54	Access Door Gasket	RP 7810863KRB
36	Ash Pan	MA CL60AP	55	Flame Impingement Shield	PS CL60-24053
38	Firebrick	PR 900050	56	By-pass Rope	RP FR2LD.750G
39	Log Retainer	MA CL60-24299	57	Grate Slide Plate	N/A
40	Bottom Grill (Black)	PO CL60-89711	65	Steel Baffle Plate	N/A
			66	Angle Iron Supports	N/A

N/A = PART NUMBER NOT AVAILABLE AT THIS TIME AND IS SUBJECT TO CHANGE

PARTS LIST

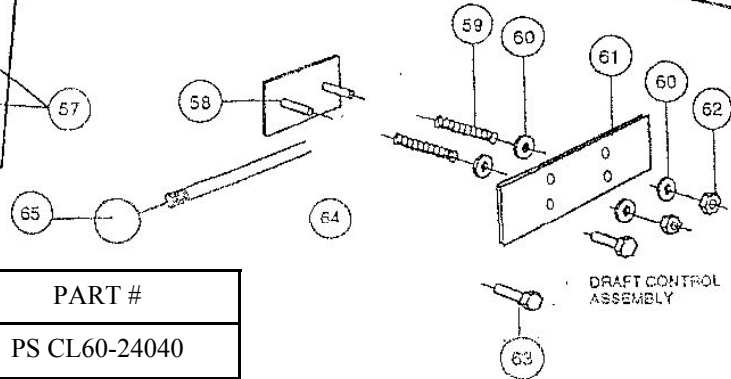
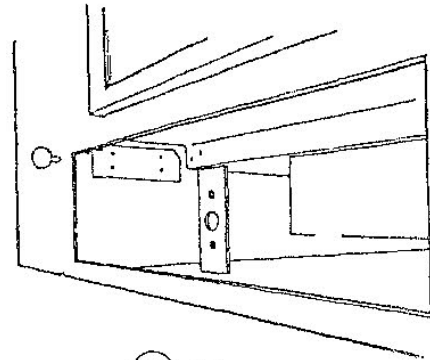
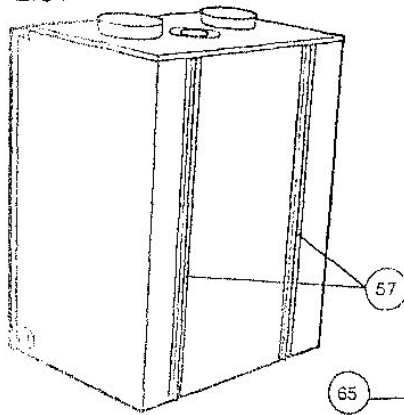

ITEM	DESCRIPTION	PART #
57	Rear Offset Brackets	PS CL60-24040
58	Slide Plate	PS CL60-24034
59	Compression Springs	PH 141SPRING
60	3/16" Flat Washers	PH 316FLW
61	Slide Plate Bracket	PS CL60-24010
62	10 - 24 Lock Nuts	PH 1024HNP
63	#10 x 1/2 Tek Screws	PH 101612TEK
64	Slide Rod	MF CL60-22015
65	Phenolic Knob	PO BC413

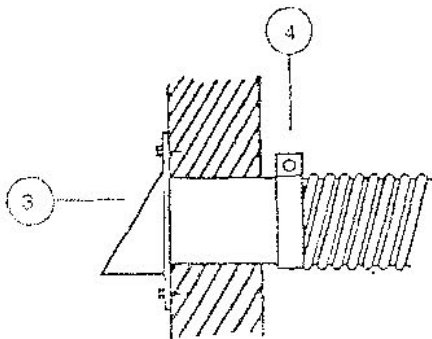
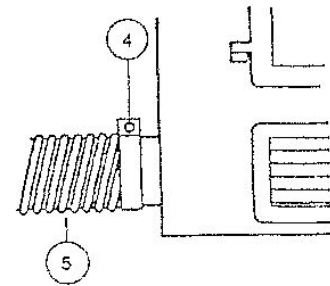

ITEM	DESCRIPTION
3	Vent
4	Clamp
5	8' x 4" Flexible Aluminum Vent Pipe

NEW BUCK CORPORATION (NBC)
“LIMITED WARRANTY” FOR THE BuckMaster STOVE
PLEASE READ THIS WARRANTY CAREFULLY

PRODUCTS COVERED

This warranty covers the new BuckMaster Stove heating unit, so long as it is owned by the original purchaser, including optional and standard accessories purchased at the same time, subject to terms, limitations, and conditions herein set out.

PRODUCTS NOT COVERED

This warranty does not cover the following:

- Glass;
- Refractory material such as refractory cement or firebrick;
- Gaskets.

This Warranty will also not cover any damage and/or failure caused by abuse or improper installation of the products covered.

WARRANTY TIME PERIODS

(A) Period I

For one year from the date of purchase, NBC will replace or repair, at its option, any part defective in materials or workmanship. The costs of parts only are included. The customer pays any labor or transportation charges required.

Thereafter

(B) Period II

For the period after the first year from the date of purchase and extending for 5 years as long as the BuckMaster Stove is owned by the original purchaser, NBC will repair or replace, at its option, any part defective in materials or workmanship, with the exception of: electrical motors, wiring, switches, and components: optional and standard accessories; and all parts not permanently attached to the heating unit. Parts not permanently attached to the heating unit are defined as those items designed to be removed from the stove, including those removable with common hand tools. The costs of parts only are included. The customer pays any labor or transportation charges required.

PROCEDURE

Should you feel that your BuckMaster Stove is defective, you should contact any Buck Stove dealer for the name of your nearest authorized Buck Stove service representative, who will instruct you on the proper procedure, depending on which Warranty Time Period (Period I or Period II) applies.

If for any reason you are dissatisfied with the suggested procedures, you may contact us in writing at:

New Buck Corporation
Customer Service Department
PO Box 69
Spruce Pine, NC 28777

CONDITIONS AND EXCLUSIONS

- (A) Replacement of parts may be in the form of new or fully reconditioned parts, at NBC’s option.
- (B) There is no other express warranty. All implied warranties of merchantability and fitness for use are limited to the duration of the Express Warranty.
- (C) New Buck Corporation is not liable for indirect, incidental, or consequential damages in connection with the use of the product including any cost or expense or providing substitute equipment or service during periods of malfunction or non-use.

Some states do not allow the exclusion of incidental or consequential damages, so the above exclusion may not apply to you.

- (D) All warranty repairs under this warranty must be performed by an authorized Buck Stove service representative. Repairs or attempted repairs by anyone other than an authorized service representative are not covered under this warranty. In addition, these unauthorized repairs may result in additional malfunctions, the correction of which is not covered by warranty.

OTHER RIGHTS

This warranty gives you specific legal rights, and you may also have other rights, which vary from state to state.

OWNER REGISTRATION CARD

The following Owner Registration Card must be completed in entirety and mailed within 30 days from the date of purchase or from the date of installation, if installed by a factory certified installer, to New Buck Corporation in order for warranty coverage to begin.

PLEASE NOTE: The Owner Registration Card must contain the Authorized Buck Stove Dealer Code Number and the Certified Installer’s number (if applicable) for warranty coverage to begin.

To be completed by selling distributor or dealer for customer:		
Name _____	(Last)	(First)
Address _____		
City _____	State _____	Zip _____
Model: <u>BuckMaster</u>		
Serial Number _____		
Date of Installation: Day _____	Month _____	Year _____
Installer’s Name _____		
Installer’s Certification Number _____		
Dealer’s Name _____		
Dealer’s Address _____		