

BRINKMANN®

Pellet Fuel Grill

Parrilla de Pellet Combustible

OWNER'S MANUAL / MANUAL DEL PROPIETARIO

**ASSEMBLY AND OPERATING INSTRUCTIONS
INSTRUCCIONES DE ARMADO Y OPERACIÓN**

**SAVE THIS MANUAL FOR FUTURE REFERENCE
GUARDE ESTE MANUAL PARA REFERENCIA FUTURA**

NOTICE TO INSTALLER:

LEAVE THESE INSTRUCTIONS
WITH THE GRILL OWNER FOR
FUTURE REFERENCE.

AVISO PARA EL INSTALADOR:

ENTREGUE ESTAS
INSTRUCCIONES AL
PROPIETARIO DE LA PARRILLA
PARA REFERENCIA FUTURA.

⚠ WARNING/ADVERTENCIA

HAZARDOUS EXPLOSION MAY RESULT IF THESE WARNINGS AND INSTRUCTIONS
ARE IGNORED. READ AND FOLLOW ALL WARNINGS AND INSTRUCTIONS IN THIS
MANUAL TO AVOID PERSONAL INJURY, INCLUDING DEATH OR PROPERTY DAMAGE.

SE PUEDE PRODUCIR UNA EXPLOSIÓN PELIGROSA SI SE HACE CASO OMISO A
ESTAS ADVERTENCIAS E INSTRUCCIONES. LEA Y SIGA TODAS LAS ADVERTENCIAS
E INSTRUCCIONES EN ESTE MANUAL PARA EVITAR LESIONES PERSONALES,
INCLUSO LA MUERTE, O LOS DAÑOS MATERIALES.





IMPORTANT SAFETY WARNINGS

WE WANT YOU TO ASSEMBLE AND USE YOUR GRILL AS SAFELY AS POSSIBLE. THE PURPOSE OF THIS SAFETY ALERT SYMBOL  IS TO ATTRACT YOUR ATTENTION TO POSSIBLE HAZARDS AS YOU ASSEMBLE AND USE YOUR GRILL.

WHEN YOU SEE THE SAFETY ALERT SYMBOL  PAY CLOSE ATTENTION TO THE INFORMATION WHICH FOLLOWS!

 READ ALL SAFETY WARNINGS AND INSTRUCTIONS CAREFULLY BEFORE ASSEMBLING AND OPERATING YOUR GRILL.

WARNING

 Do NOT use in humid or wet conditions

WARNING

1. Improper installation, adjustment, service or maintenance can cause injury or property damage.
2. Read all instructions and guidelines carefully and thoroughly before installation, use or service.
3. Failure to follow these instructions could result in fire or electrical shock.

DANGER

 NOT for use in or on boats or recreation vehicles.

DANGER



1. Do not store or use gasoline, liquid propane or any other flammable vapors or liquids in the vicinity of this appliance.

TABLE OF CONTENTS:

General Warnings	3-4
Operating the Grill	5-8
Proper Care and Maintenance	9
Transporting and Storage	10
Cooking Grill Tips	10
Trouble Shooting	11
Wiring Diagram	12
Assembly Instructions	13-21
Warranty Information	Back Cover

⚠ DANGER: Indicates an imminently hazardous situation which, if not avoided, will result in death or serious injury.

⚠ WARNING: Be alert to the possibility of serious bodily injury if the instructions are not followed. Be sure to read and carefully follow all of the messages.

⚠ CAUTION: Indicates a potentially hazardous situation which, if not avoided, may result in minor or moderate injury.

CALIFORNIA PROPOSITION 65 WARNING

This product contains chemicals, including lead in the brass of certain component parts, that are known to the State of California to cause cancer, and birth defects or other reproductive harm. *Wash hands after handling.* When used, this product emits fuel combustion chemicals that are known to the State of California to cause cancer, and birth defects or other reproductive harm. *Follow all instructions in this manual and use only in well ventilated, outdoor area.*

FOR COVERS, ACCESSORIES AND OTHER PRODUCTS, PLEASE VISIT US ONLINE AT:

WWW-BRINKMANN-NET

GENERAL WARNINGS:

⚠ WARNING

When using electric appliances, basic safety precautions should always be followed including the following:

- Operate only per manufacturers instructions.
- Keep all combustible materials at least 72 inches (183 cm) away from the grill at all times. Do not use this grill under any overhang or near any combustible structures.
- Minimum clearance from side and back of unit to construction, 72 inches (183 cm) from sides and 72 inches (183 cm) from back.
- DO NOT use on wood decks.
- In case of fire, turn the control "OFF". Unplug the grill from the power source and allow the fire to burn out on its own. Do not use water to try to extinguish a fire.
- Keep a fire extinguisher on hand acceptable for use with electric products. Refer to your local authority to determine proper size and type.
- Do not attempt to touch cooking surfaces or other hot surfaces. Use handles or knobs.
- To protect against electric shock, do not immerse cord, plugs, or heating element in water or any other liquids.
- Never leave appliance unattended. Do not allow children or pets near a working appliance.
- Unplug this grill from the power source when not in use and before cleaning. Allow appliance to cool down before attempting to clean or service.
- Do not operate any appliance with a damaged power cord or plug, or after the appliance has malfunctioned or been damaged in any manner.
- Do not use accessories or attachments not recommended by the manufacturer, as they may not be compatible with this appliance, and may cause damage or injury.
- Do not place power cord where it may come in contact with hot surfaces, or pose a tripping hazard.
- Do not use this appliance for anything other than its intended use.
- NEVER add cooking pellets to a hot fire pot by hand. You could be seriously burned. If the hopper runs out of pellets or your fire goes out while cooking, let the grill completely cool and follow the Initial Lighting Instructions.
- Use only cooking grade wood pellets. Never use heating grade wood pellets as they are not safe for cooking.
- Always store wood pellets away from heat.
- Do not use grill lighter fluid, charcoal, lava rocks, gasoline, kerosene, or alcohol with this grill.
- This grill is not for use indoors. Do not use inside a building, garage or any other enclosed area.
- This product is not designed for commercial use.
- This product is not designed for tabletop use. Do not set this product on a tabletop.
- Never place more than 15 pounds on the front shelf. DO NOT lean on the front shelf. DO NOT lift grill using front shelf.

- Outdoor extension cords must be used with outdoor use products and are marked with suffix “W” and with the statement “Suitable for Use with Outdoor Appliances.”
- Only use a properly-grounded power source.
- Use only with a properly-grounded GFCI (Ground Fault Circuit Interrupter) household circuit.
- Do not operate this product in rain or wet conditions. Do not allow this product to come in contact with water. Set this product up more than 10’ from any large body of water (swimming pool, lake, pond, etc).
- **CAUTION** - To reduce the risk of electric shock, keep extension cord connection dry and off the ground.
- Never alter or remove the grounding plugs on the power cord or household outlet.
- Disconnect electric cord from outlet before cleaning.
- Keep appliance clean. See Proper Care and Maintenance section for cleaning.
- Do not operate this grill while under the influence of drugs, alcohol, or while fatigued.
- Do not use in the presence of explosive or flammable gases, vapor or other substances.
- Do not use this grill unless it is completely assembled and all parts are securely fastened and tightened.
- Use only identical replacement parts.
- Do not use this product in high winds.
- Do not attempt to move this appliance while it is in use.
- Always open the grill lid carefully - heat and steam trapped inside the lid can burn.
- Set up this grill on a hard, non-combustible smooth level surface.
- Do not use this product for indoor heating, as toxic fumes will accumulate.
- After a period of storage, inspect the grill for abrasion, wear, cuts, or damage to the temperature controller and power cord.
- Always use a meat thermometer to ensure food is cooked to a safe temperature.
- Keep grill covered when not in use - out of the reach of children. Do not clean this product with a water spray or the like.
- Unplug from outlet when not in use and before cleaning. Allow to cool before putting on or taking off parts.
- Do not operate any appliance with a damaged cord or plug or after the appliance malfunctions or is dropped or damaged in any manner.

**⚠ USE CAUTION AND COMMON SENSE WHEN OPERATING
YOUR PELLET FUEL GRILL.**

**FAILURE TO ADHERE TO THE SAFETY WARNINGS AND GUIDELINES IN THIS MANUAL
COULD RESULT IN DEATH, SEVERE BODILY INJURY OR PROPERTY DAMAGE.**

SAVE THIS MANUAL FOR FUTURE REFERENCE.

OPERATING THE GRILL:

WARNING

Read and follow all warnings and instructions contained in the preceding sections of this manual.

BREAKING IN YOUR GRILL:

- In manufacturing and preserving the components of your grill, oil residue may be present on the cooking surfaces of your grill.
- Before cooking on your grill for the first time you should follow “Initial Lighting Instructions” to ensure the auger is fully charged with pellets.

PREHEATING THE GRILL:

- Prior to use, it is recommended that you preheat your grill. This ensures that the grilling surfaces are at the desired temperatures to sear the food sugars when cooking. Preheat the grill for 10 to 15 minutes or until it reaches the desired temperature before adding food. Close the lid during the preheat period.

WARNING

- **DO NOT** leave your grill unattended while in use.
- **DO NOT** move grill when in use. Block wheels in place to stabilize grill.
- **DO NOT** use water to extinguish flare-ups.

IF AN EXTENSION CORD IS NECESSARY:

- Use a CSA or UL approved 3-prong grounded extension cord that is rated for at least 7-10 Amp and is marked as suitable for outdoor use.
- Keep the power cord connection dry and off of the ground.
- Avoid running the power or extension cord across walkways, driveways, or anywhere where it could pose a tripping hazard.

TURNING ON THE GRILL:

Initial Lighting Instructions (To be used on initial firing or anytime the grill runs out of pellets)

Always allow the auger tube to fully load with pellets to ensure proper lighting of the grill.

- Step 1** Open lid to cooking chamber and remove cooking grills, grease tray and heat distribution plate from inside the grill. Leave lid open.
- Step 2** Make sure temperature control knob is “OFF”. Plug power cord into a GFCI (grounded) outdoor electrical outlet.
- Step 3** Open the pellet hopper lid. Make sure the auger is free from debris and other objects. Turn the temperature control knob to “SMOKE” and check to see if the auger is turning.
- Step 4** In the cooking chamber, place your hand about 3” above the fire pot and make sure you can feel air blowing out from the fire pot.
- Step 5** Look inside the fire pot and make sure the heating element is getting hot. It will take a couple of minutes for the element to glow red. **DO NOT TOUCH THE HEATING ELEMENT!** Turn temperature control knob to “OFF”.
- Step 6** Fill the pellet hopper with cooking pellets. **NEVER USE HEATING FUEL PELLETS AS THEY ARE NOT SAFE FOR COOKING.**
- Step 7** Turn the temperature control knob to “HIGH”.
- NOTE:** During the initial loading of the auger tube, it will take approximately 5 minutes for the pellets to move from the pellet hopper to the fire pot.
- Step 8** When the pellets start falling into the fire pot, turn the temperature control knob to “OFF”.
- Step 9** Replace heat distribution plate, grease tray and cooking grills into the cooking chamber.
- Step 10** Keep the cooking chamber lid open. Turn temperature control knob to “SMOKE”. You should see smoke coming out of the cooking chamber as the pellets ignite in about 2 minutes.
- Step 11** Close cooking chamber lid and set the temperature control knob to the desired setting. See note below for curing process.

NOTE: Curing the grill is highly recommended before first use. Close cooking chamber lid and set temperature control knob to “HIGH” and allow grill to cure for 45 minutes. This will burn off any oil or paint residue inside the cooking chamber before cooking for the first time.

Subsequent Lighting Instructions

- Step 1** Open pellet hopper lid and check the pellet level. Add more pellets if necessary.

⚠ WARNING: NEVER add cooking pellets to a hot fire pot by hand. You could be seriously burned. If the hopper runs out of pellets or your fire goes out while cooking, let the grill completely cool and follow the Initial Lighting Instructions.

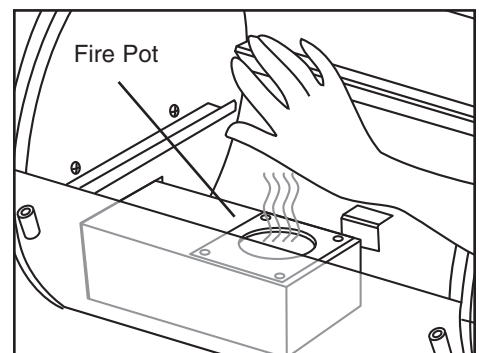
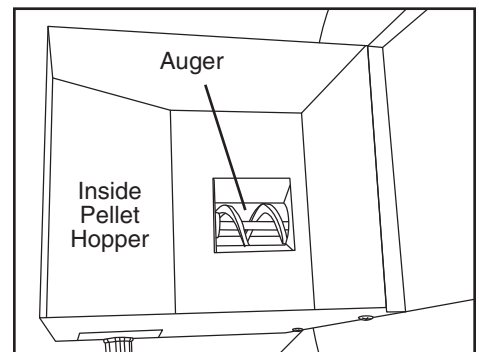
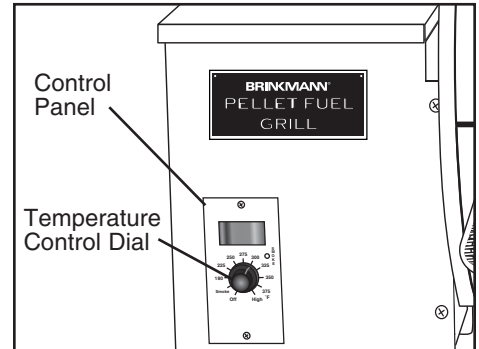

Step 2 Open cooking chamber lid and turn temperature control knob to “SMOKE”. You should see smoke coming out of the cooking chamber as the pellets ignite in about 2 minutes.

NOTE: Always start the grill on “SMOKE” setting with the cooking chamber lid open.

Step 3 Close cooking chamber lid and set the temperature control knob to the desired setting. For best results, preheat the grill for 10 to 15 minutes with the lid closed before placing food in the grill.

Follow these steps if the grill does not ignite or if the fire in the fire pot goes out while cooking:

Step 1 Turn the temperature control knob to “OFF” and unplug. Open cooking chamber lid and remove all food, cooking grills, grease tray and heat distribution plate.

⚠ CAUTION: Some parts may contain sharp edges. Wear protective gloves if necessary.

⚠ WARNING: Always use oven mitts/gloves to protect your hands. Metal parts become hot during use. Use extreme caution when handling cooking grills, grease tray and heat distribution plate.

Step 2 Remove all unburned pellets and ash from inside and around the fire pot.

Step 3 Restart the grill and check that the ignition cycle is working. The heating element should turn red after 1-2 minutes and pellets should be falling into the fire pot from the auger tube.

Step 4 Wearing oven mitts/gloves, replace the heat distribution plate, grease tray and cooking grills.

Step 5 Preheat the grill for 10 to 15 minutes with the lid closed before placing food back in the grill. If this procedure is not successful, see Trouble Shooting section in your owner’s manual.

TURNING OFF THE GRILL:

- Turn the switch to “OFF”.
- Unplug the power cord from the wall outlet.

⚠ WARNING: NEVER add cooking pellets to a hot fire pot by hand. You could be seriously burned. If the hopper runs out of pellets or your fire goes out while cooking, let the grill completely cool and follow the Initial Lighting Instructions.

COOKING:

- Set temperature controller to desired level and allow temperature to be reached.
- Place food on cooking grill.
- With lid open or closed, cook until desired internal temperature is reached.
- Use caution when removing food from Pellet Fuel Grill. All surfaces are HOT and may cause burns. Use protective gloves or long, sturdy cooking tools to remove food.
- Pellet Fuel Grill is HOT while in use and will remain HOT for a period of time afterwards. Use caution.

OPERATING TIPS:

- Your Brinkmann Pellet Fuel Grill should never be moved while it is hot. If you are transporting your grill in a vehicle after cooking on it, make sure the fire is completely out and the grill is cold before placing it in any vehicle. NEVER put water into the fire pot. It will jam the auger.
- The Brinkmann Pellet Fuel Grill is designed to operate with the lid closed. Cooking with the lid open greatly lengthens your cooking time.
- Make sure the heat distribution plate is properly seated on its locating brackets. The long legs of the heat distribution plate should be pointing down over the fire pot. If not seated properly, direct heat and flame could come up out of the fire pot and cause a grease fire in the grill.

- Smoke stack cap can be adjusted up or down to provide additional temperature and smoke control.

SMOKE MODE:

- The “SMOKE” settings is for smoking and adding smoke flavor to foods being cooked.
- Smoke Mode can be adjusted from P0 to P7. P0 provides less smoke into the cooking chamber and can be adjusted up to P7 for maximum smoke.
- Adjusting the smoke mode to a higher setting will cause more fluctuation in the temperature of the cooking chamber. P3 or P4 is the normal factory setting.



COOK MODE:

- The temperature dial can be changed at any time to increase or decrease the cooking temperature of the grill.
 - The 325°F to “HIGH” temperature settings are for grilling.
 - The 180°F to 300°F temperature settings are for slow cooking.
- Adjust the control knob to a desired temperature. The selected temperature will be in the bottom left hand corner of the digital display.
- Adjusting the smoke mode to a higher setting will cause more fluctuation in the temperature of the cooking chamber.
- Smoke Mode can be adjusted from P0 to P7. P0 provides less smoke into the cooking chamber and can be adjusted up to P7 for maximum smoke.

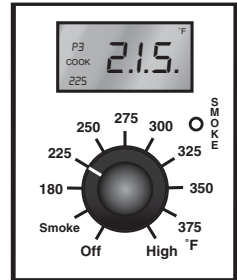

ERROR CODES:

- “8.8.8.” – Display will flash for 1-2 seconds when first plugged into power outlet. This is normal, not an indication of a problem.
- “ErP” – Error Power will occur when grill is plugged into power outlet and the temperature control knob is not in “OFF” position.
- “. . .” – Flashing Dots indicate that the igniter is “ON”. The igniter will stay on for 5 minutes and then go off.
- “ErH” – High Temp Limit indicates that the temperature in the cooking chamber has exceeded 565°F.
- “1.0.5.” – Flashing Temperature indicates temperature is below 110°F on “SMOKE” setting or temperature is below 150°F on all cooking temperatures.
- “Err” – Thermocouple may be unhooked or damaged.



PROPER CARE & MAINTENANCE:

- Remove wood pellets from hopper if grill will not be used for a long period of time. Wood pellets can become soggy due to moisture/humidity and can cause the auger to bind up or not push pellets to burn chamber.
- To protect your grill from excessive rust, the unit must be kept clean and covered at all times when not in use.
- Wash cooking grills and heat distribution plate with hot, soapy water, rinse well and dry. Lightly coat cooking grill with vegetable oil or vegetable oil spray.
- Clean inside and outside of grill by wiping off with a damp cloth. Apply a light coat of vegetable oil or vegetable oil spray to the interior surface to prevent rusting.
- Never apply paint to the interior surface. Rust spots on the interior surface can be buffed, cleaned, then lightly coated with vegetable oil or vegetable oil spray to minimize rusting.
- Depending on use, periodically remove the cooking grills, grease tray and heat distribution plate to clean the ash from in and around the fire pot. A shop-vac is handy for this chore. Make sure the grill is cold before starting this procedure.

HELPFUL HINTS:

- If you pre-cook meat or poultry, do so immediately before grilling.
- Never defrost meat at room temperature or on a countertop.
- Refrigerate leftovers within 2 hours of taking food off the grill.
- For additional information, please phone the USDA's toll free Meat & Poultry Hotline at 800-535-4555.

CLEANING AND MAINTENANCE:

- Keep the appliance free and clear of combustible materials, gasoline and other flammable vapors and liquids.
- For safe grilling and peak performance of your grill, perform these checks at least twice per year or after extended periods of storage.
- Be sure to tighten up all hardware (nuts, bolts, screws, etc.) at least twice per year.

⚠ CAUTION: Some parts may contain sharp edges. Wear protective gloves if necessary.

- Remove the cooking grills, from inside your grill. Use a brush with hot water and detergent to remove excess residue. NEVER use a commercial oven cleaner. Rinse completely with water. Towel dry and replace all components as described in the assembly instructions.

COOKING GRILLS:

- Clean with mild soap detergent and water. Use a grill cooking grate brush to remove residue from the porcelain coated surfaces. The steel wire can cause the finish to chip or crack. DO NOT use a commercial oven cleaner.

TRANSPORTING AND STORAGE:

WARNING

- Never move a grill when it is hot or when objects are on the cooking surfaces.
- Never store flammable liquids or spray canisters under or near the grill.
- DO NOT extinguish grease fires using water.

BEFORE STORING YOUR GRILL:

- Clean all surfaces.
- If storing the grill outdoors, close the wood pellet lid and cover the grill with a grill cover for protection from the weather.
- If the grill is stored outside during the rainy season, care should be taken to ensure that water does not get into the pellet hopper. Wood pellets, when wet, expand greatly and will jam your auger.

GRILL COOKING TIPS:

CLEANLINESS:

- Always wash hands thoroughly with soap and hot water prior to handling food and after handling raw meat, uncooked poultry or seafood.
- When using a platter to carry raw meat, uncooked poultry or seafood to the grill, make sure to wash the platter thoroughly with soap and hot water before placing cooked foods back on the platter or use different platters for raw and cooked foods.
- Never use the same utensils when handling raw meat, uncooked poultry or seafood unless you wash the utensils thoroughly with soap and hot water.
- Never re-use marinade from raw meat or uncooked poultry on foods that have been cooked and are ready to be served.

GRILLING TO PROPER TEMPERATURE:

- Use a meat thermometer to be sure food has reached a safe internal temperature.
- The US Department of Agriculture recommends the **minimum** temperature be reached for the following food items:

Chops	145 degrees F (62.8° C)
Ground Meat	160 degrees F (71° C)
Pork	145 degrees F (62.8° C)
Poultry	165 degrees F (73.9° C)
Roasts	145 degrees F (62.8° C)
Seafood	145 degrees F (62.8° C)
Vegetables	145 degrees F (62.8° C)

TROUBLE SHOOTING:

To see trouble shooting or assembly videos, visit us at: [www.BRINKMANN-NET](http://www.brinkmann-net)

PROBLEM	CAUSE	CORRECTION
Electric element will not heat up	<ol style="list-style-type: none"> 1. Check that the 3-wire plug is fully seated into a 3-wire grounded GFCI outlet wired for 120 volts and protected at 7 or 10 amps. 2. Check the breakers or fuses for the outlet being used are not open or shorted. 3. Check that the GFCI outlet has not been tripped. 4. Electric element only heats up (becomes red) during the first 5 minutes after power switch is turned on. 	<ol style="list-style-type: none"> 1. Reseat plug in a 3-wire grounded GFCI outlet wired for 120 volts and protected at 7 or 10 amps. 2. Reset breakers or replace fuse. 3. Reset GFCI outlet. 4. Turn Power switch “Off” then “ON” again.
Grill is not getting hot enough	<ol style="list-style-type: none"> 1. Adjust temperature control on temperature controller. 2. Avoid the temptation to check food too often. 3. Verify that there are pellets in pellet hopper. 4. Fire goes out on “SMOKE” setting. 	<ol style="list-style-type: none"> 1. Turn up heat on control dial. 2. Opening the door allows heat to escape and slows the cooking process; open door only when necessary. 3. Add pellets and allow sufficient time for the pellets to travel from the pellet hopper to the firepot (can take up to 7 minutes). 4. Excess ash. IMPORTANT: Remove all unburned pellets and ash from inside and around the firepot. A shop-vac is ideal for the task CAUTION! ASSURE THAT THE GRILL IS COLD TO AVOID A FIRE FROM HOT ASH.
Grill is getting too hot	<ol style="list-style-type: none"> 1. Adjust temperature control. 	<ol style="list-style-type: none"> 1. Turn down heat on temperature control dial.
Smoke comes out of smoker box	<ol style="list-style-type: none"> 1. This is normal due to the air pressure inside the smoker. The amount of smoke can vary depending on cooking conditions. 	<ol style="list-style-type: none"> 1. This condition will not affect cooking.
Temperature or digital display does not match “set” temperature	<ol style="list-style-type: none"> 1. When first lighting smoker, it takes 15 minutes or so for temperature to stabilize. 2. When adjusting temperature, it takes 15 minutes or so for temperature to stabilize. 	<ol style="list-style-type: none"> 1. Wait 15 minutes or so for temperature to stabilize.

WIRING DIAGRAM:

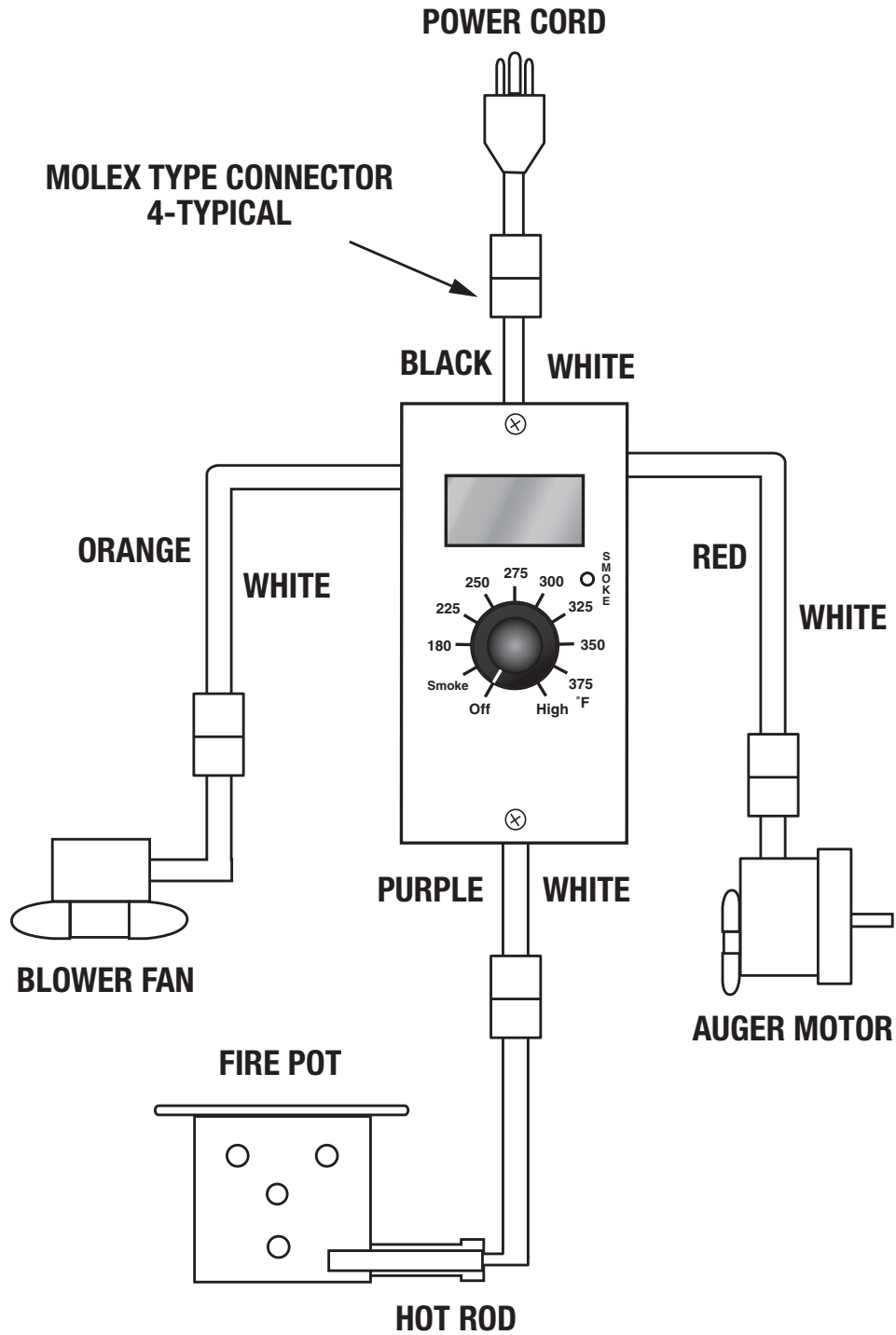

NOTE: FUSE IS LOCATED ON BACK OF CONTROL.

ASSEMBLY INSTRUCTIONS:

Make sure you have all items listed under **PARTS LIST** and **PARTS CARD CONTENTS** before you begin the installation process.

PARTS CARD CONTAINS:

30 M6 X 12 mm Bolts

16 M6 Flat Washers

26 M6 Nuts

2 M12 Nuts

1 M6 X 14 Shoulder Bolt

M6 X 12 mm Bolts

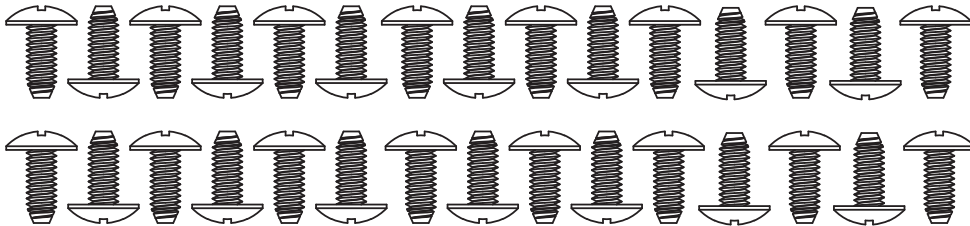

M6 Nuts

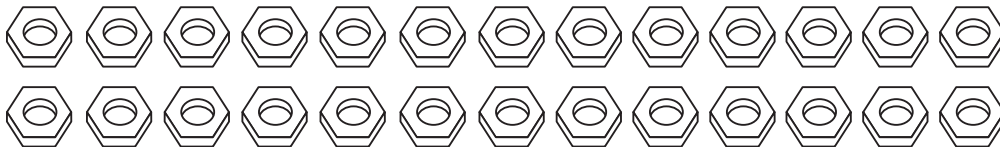

M6 Flat Washers

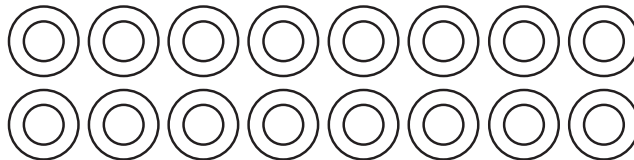

M6 X 14 mm Shoulder Bolt

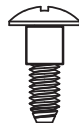

M12 Nut



**▲ READ ALL SAFETY WARNINGS & ASSEMBLY INSTRUCTIONS CAREFULLY
BEFORE ASSEMBLING OR OPERATING YOUR GRILL.**

WE RECOMMEND TWO PEOPLE WORK TOGETHER WHEN ASSEMBLING THIS UNIT.

The following provided tools are required to assemble this Brinkmann® Pellet Fuel Grill:

- **Screwdriver**
- **Adjustable Wrench**

PARTS LIST:

① 3	Cooking Grills	⑩ 1	Grease Drainage Tray
② 1	Grease Tray	⑪ 1	Grease Bucket
③ 1	Heat Distribution Plate	⑫ 1	Wheel Axle with Washers and Nuts
④ 1	Wood Pellet Hopper Assembly	⑬ 1	Left Rear Leg (with Axle Holes)
⑤ 1	Grill Body Assembly	⑭ 1	Left Front Leg (with Axle Holes)
⑥ 1	Smoke Stack Cap	⑮ 1	Right Rear Leg (without Axle Holes)
⑦ 1	Smoke Stack Assembly	⑯ 1	Right Front Leg (without Axle Holes)
⑧ 1	Front Shelf	⑰ 1	Bottom Shelf
⑨ 1	Side Handle	⑱ 2	Wheels

To see trouble shooting or assembly videos, visit us at: **WWW-BRINKMANN-NET**

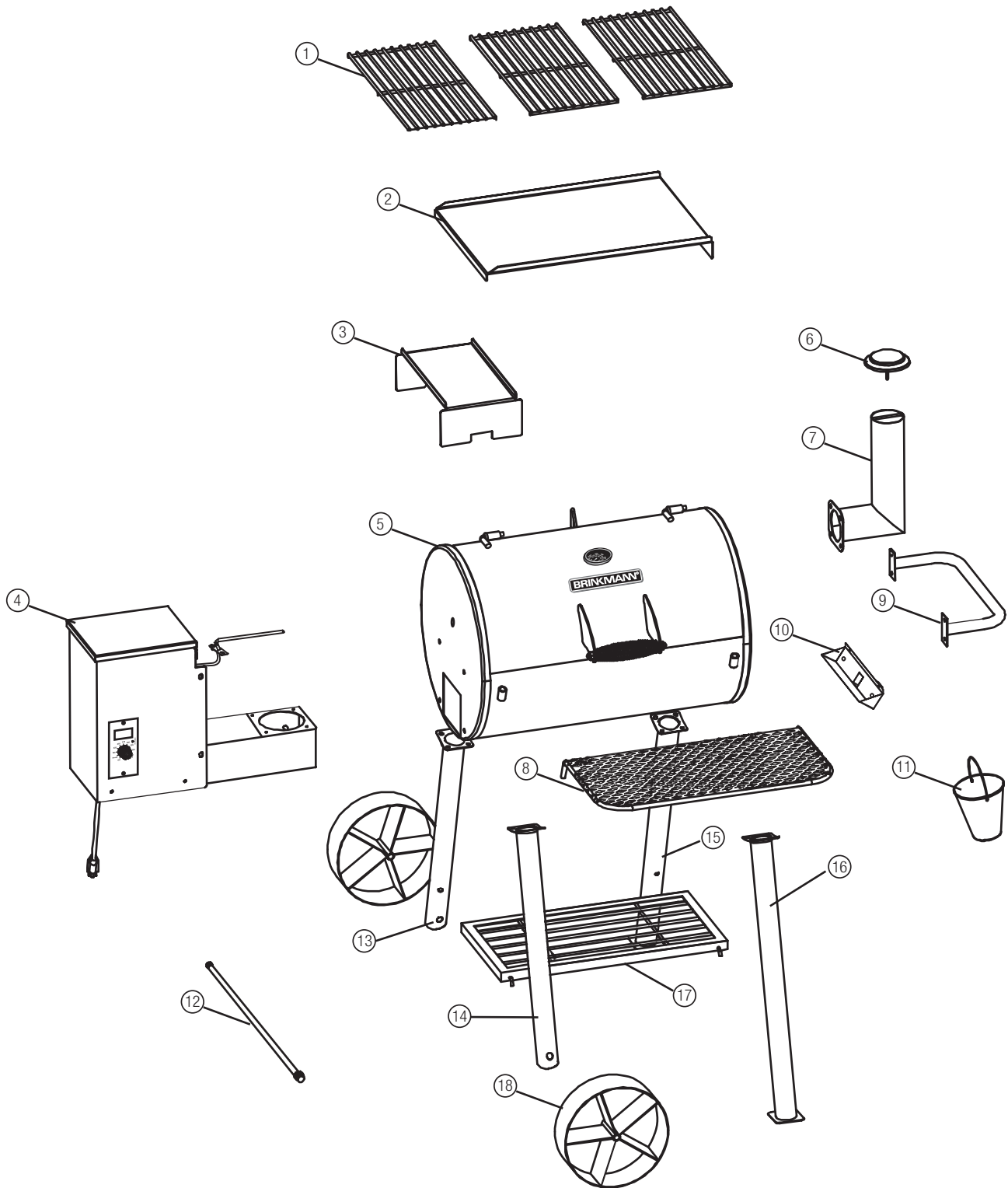

FOR COVERS, ACCESSORIES AND OTHER PRODUCTS, PLEASE VISIT US ONLINE AT:
WWW·BRINKMANN·NET

Inspect contents of the box to ensure all parts are included and undamaged.

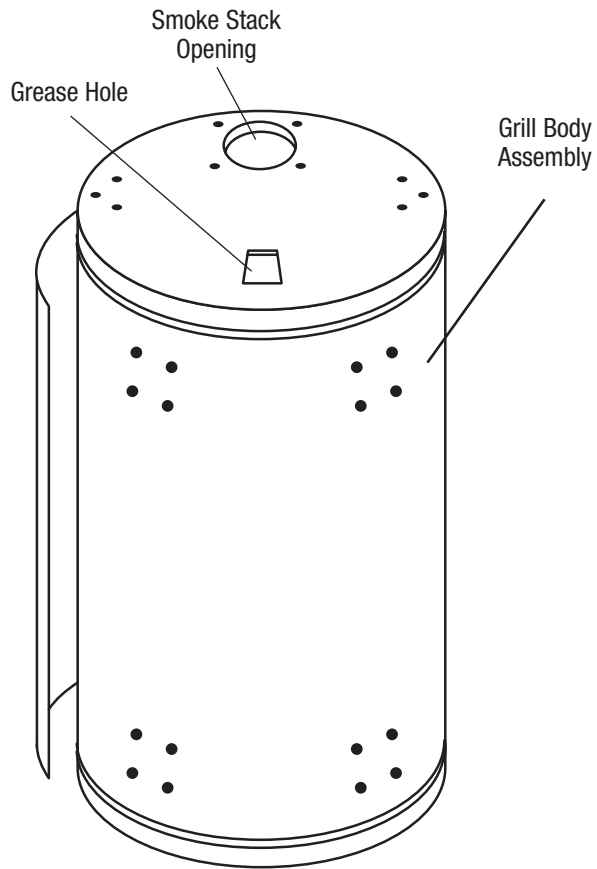

Clear an assembly area and get a friend to help you put your smoker together. Lay cardboard down to protect smoker finish and assembly area.

Step 1

Place the grill body assembly on its end with the lid open. Make sure that another person is holding the grill body assembly steady. The opening to the smoke stack and grease drainage tray hole should be facing up as illustrated.

Step 2

With the grill body assembly standing on its side as in Step 1, attach the right rear leg (without axle holes) to the grill body assembly. Align the bolts of leg with the pre-drilled holes in the grill body assembly as illustrated. Attach using four M6 X 12 mm bolts, M6 flat washers and M6 nuts. Hand tighten only. Do not attach the right front leg yet.

Step 3

Insert the bottom shelf (curved end pointed down) into the mounted right rear leg. Insert bottom shelf into right front leg. Attach right front leg onto grill body assembly using the same technique described in Step 2.

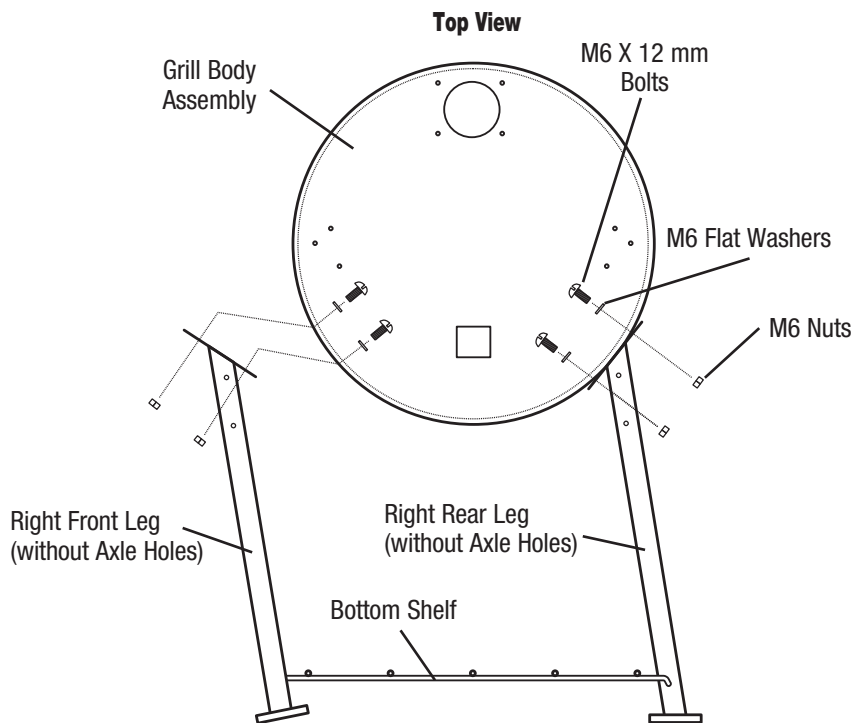

Step 4

Attach the left front and rear legs (with wheel axle holes) to the grill body assembly. First, insert the bottom shelf into the left rear leg, then move bolted end of leg until bolts align with holes in the grill body assembly. Attach using four M6 X 12 mm bolts, M6 flat washers and M6 nuts. Hand tighten only. Repeat this step for left front leg. Tighten all bolts and nuts for each leg attached to the grill body assembly.

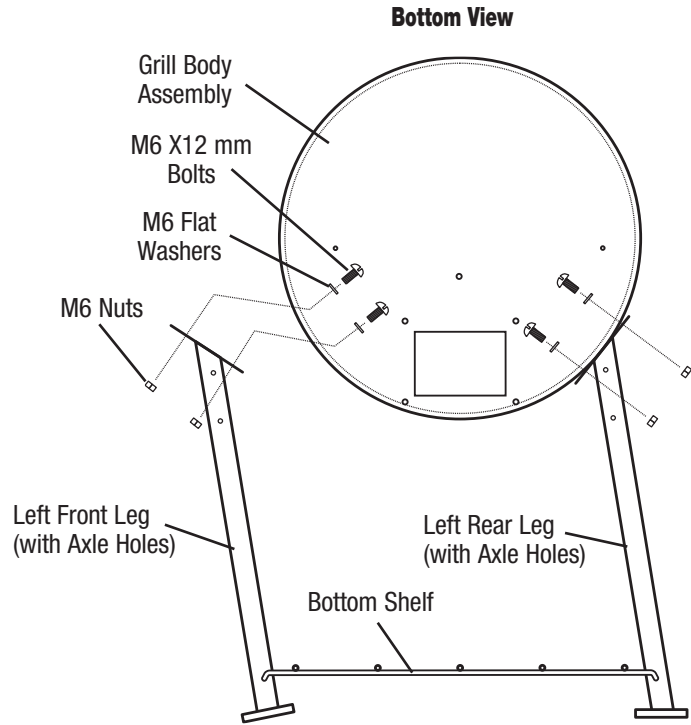

Step 5

Insert wheel axle through left front and rear legs and attach wheels using two M12 nuts as illustrated. Tighten securely.

Note: With the help of a friend, lift the grill body assembly to an upright position. Try to minimize the stress to the legs.

CAUTION: Keep lid closed when setting unit upright to prevent bodily injury.

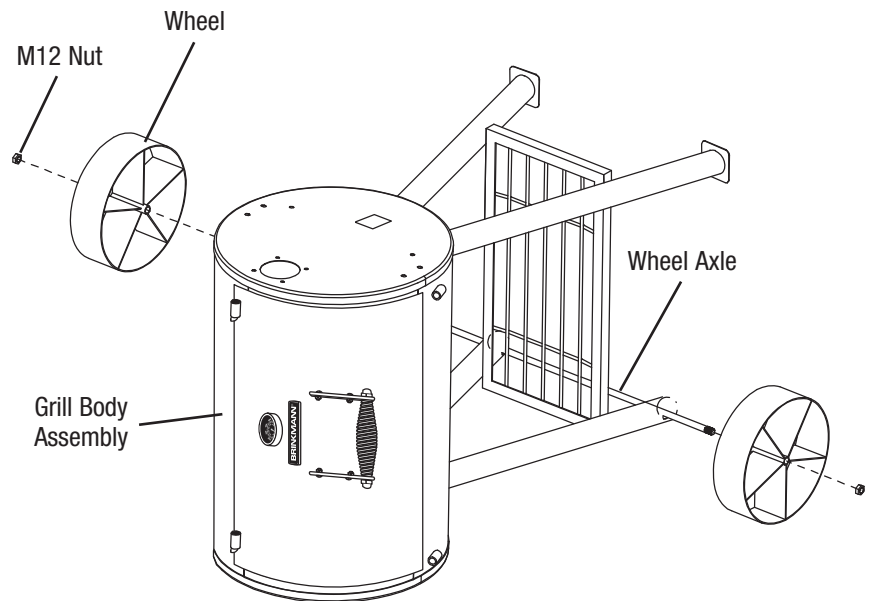

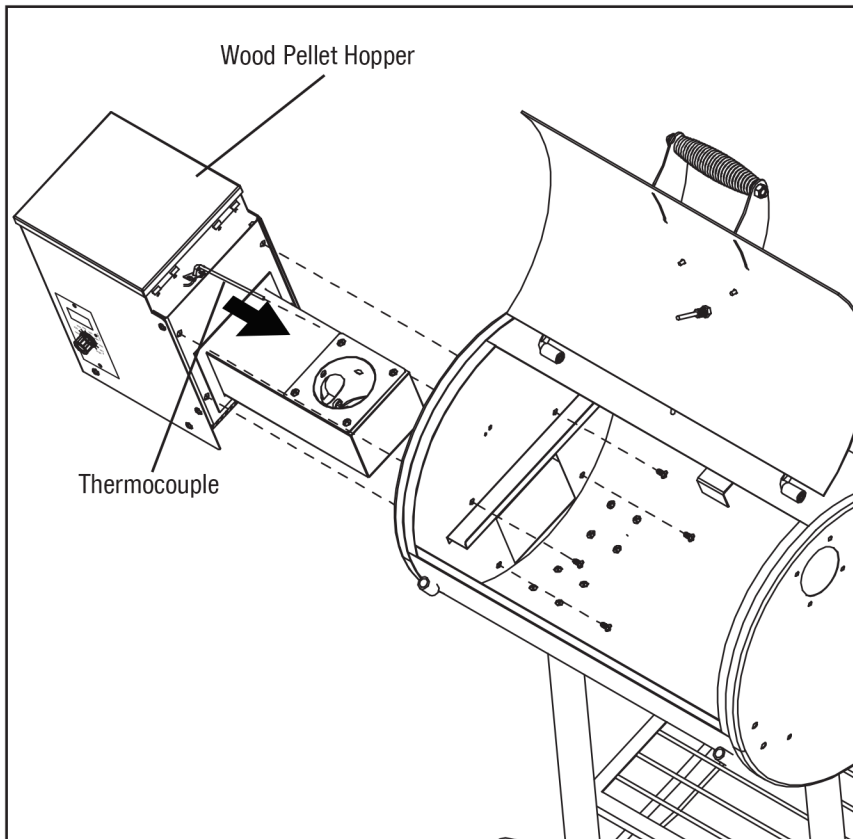

Step 6

Attach the wood pellet hopper assembly to the left side of grill body assembly using four M6 X 12 mm bolts. When installing pellet hopper assembly, insert thermocouple into hole on left side of grill body assembly and secure with pre-installed bolt and nut.

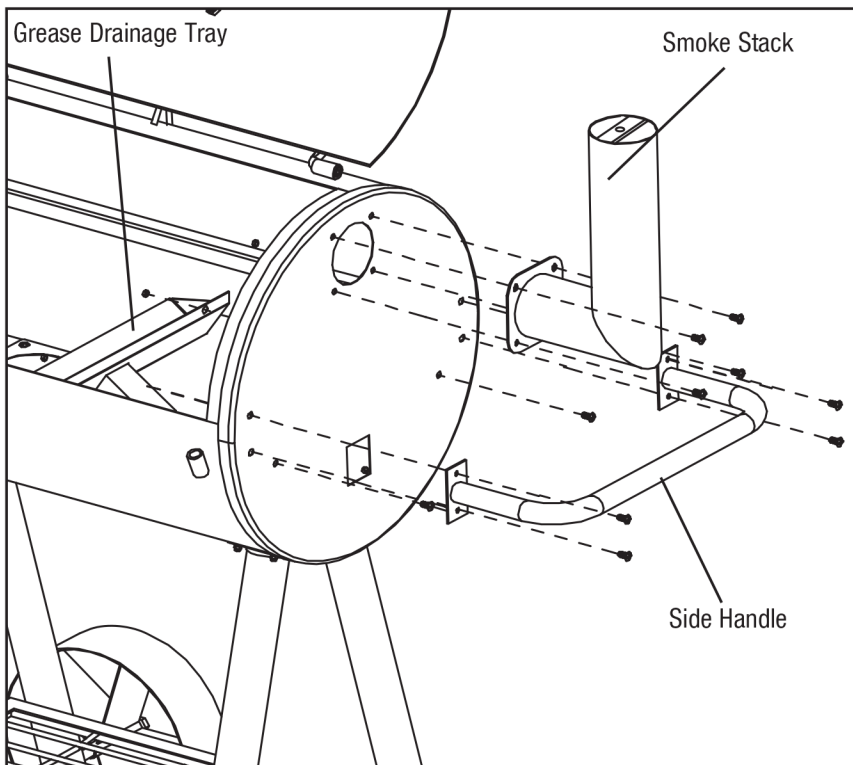

Step 7

Attach smoke stack assembly, side handle and grease drainage tray to right side of grill body assembly using ten M6 X 12 mm bolts and M6 nuts.

Step 8

Screw on smoke stack cap to the top of smoke stack. Then insert one M6 X 14 mm shoulder bolt in grease drainage tray spout as illustrated.

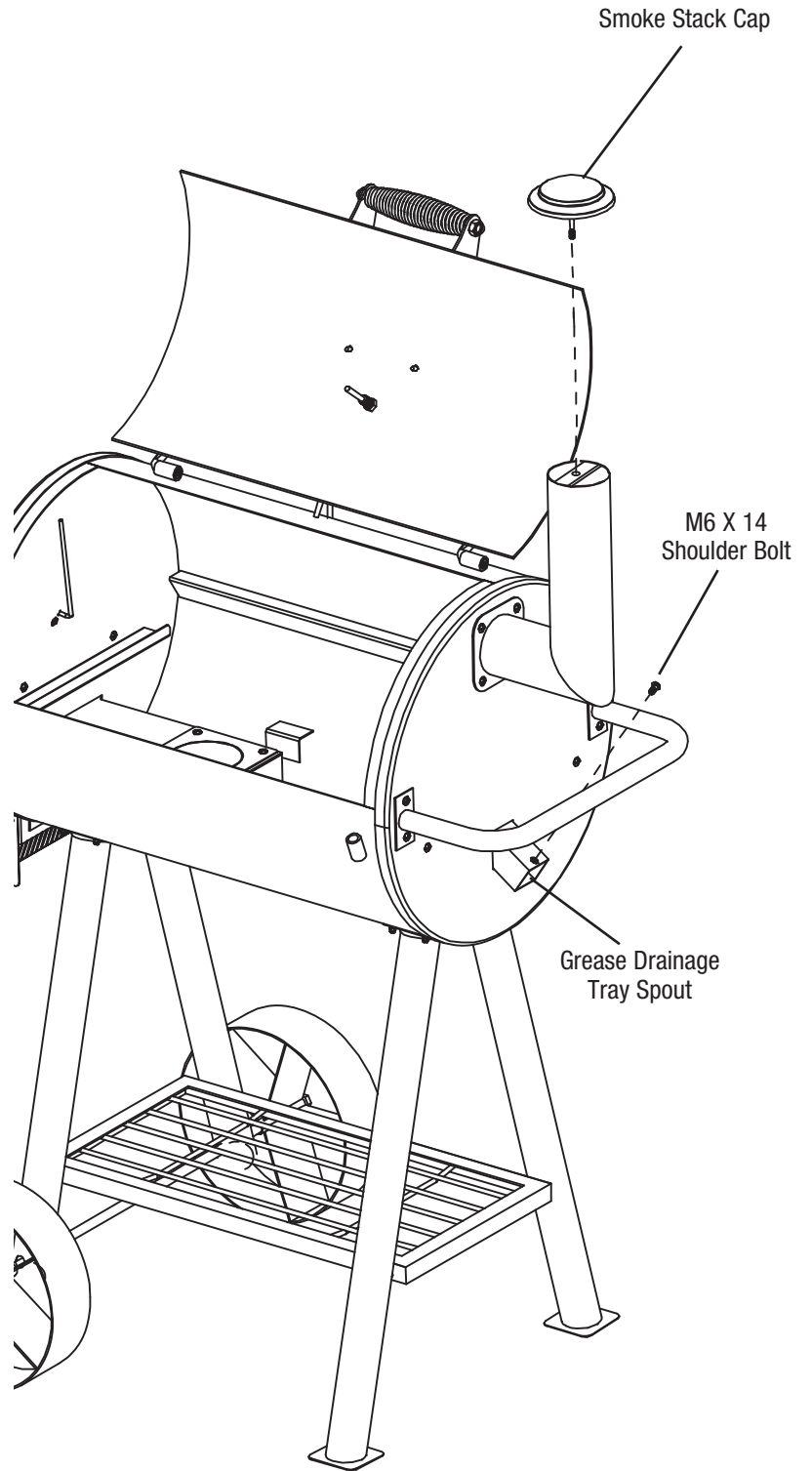

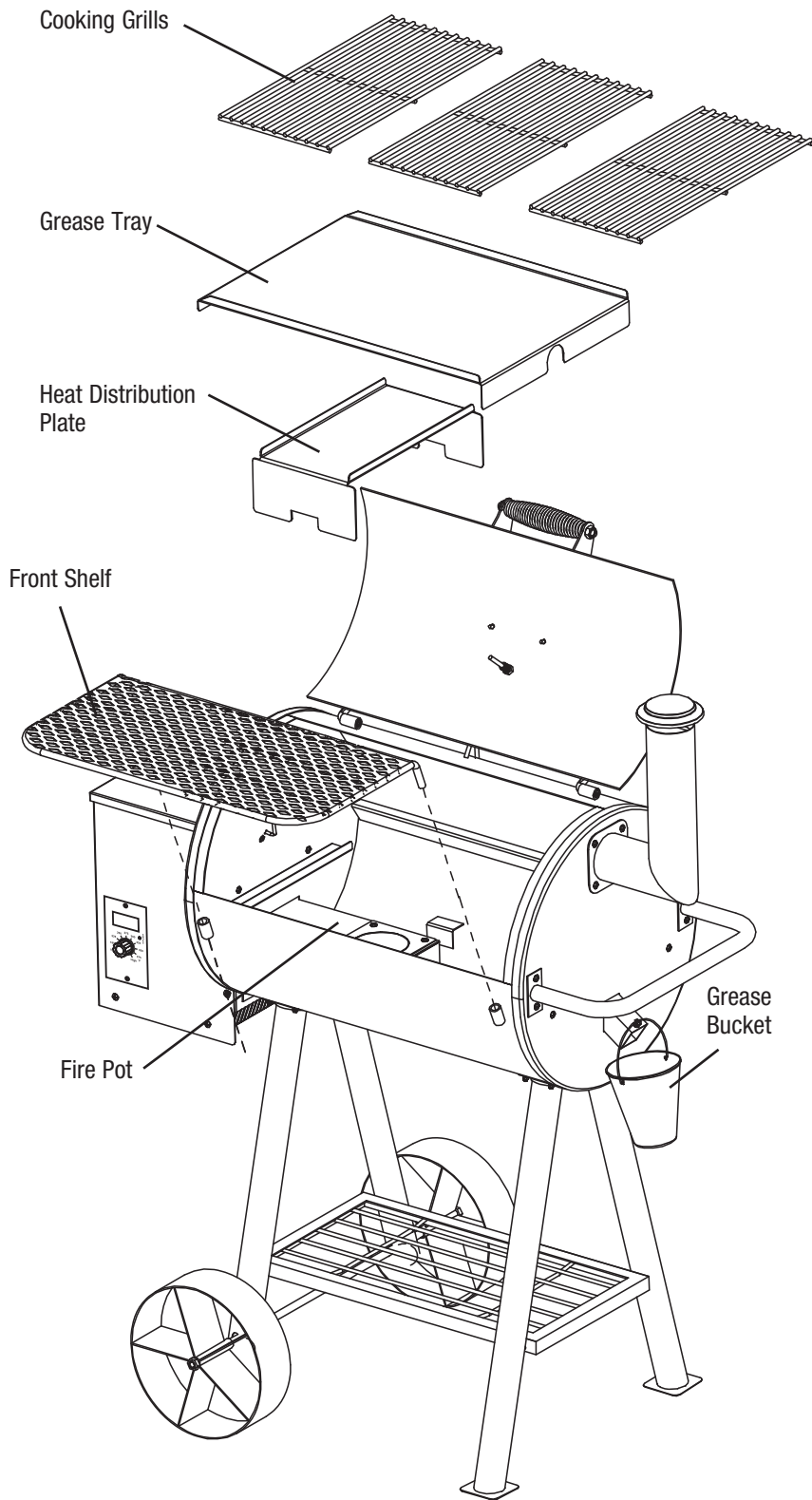

Step 9

Open lid. Place heat distribution plate on top of fire pot down inside grill body assembly.

Step 10

Place grease tray on support ribs directly above heat distribution plate.

Step 11

Place cooking grills on support ribs directly above grease tray.

Step 12

Insert front shelf in holes on grill body assembly as illustrated.

Step 13

Hang the grease bucket on shoulder bolt above the grease hole.

Brinkmann® 3091 (Assembled)

