



OWNER'S MANUAL

Model 1944 v08.2

22" GRIDDLE

WITH HOOD AND FOLDING LEGS



CONFORMS TO ANSI STD. Z 21.89-2017
CERTIFIED TO CSA STD. 1.18-2017
OUTDOOR COOKING SPECIALTY GAS APPLIANCES.

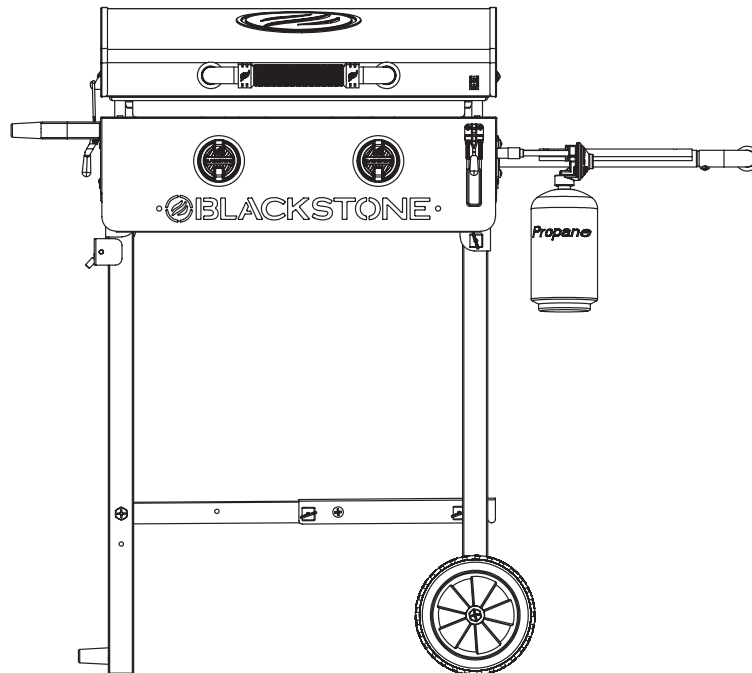

ENGLISH

Please reference blackstoneproducts.com/support for the latest version of this manual, and to follow along with assembly videos.



⚠ WARNING

INSTALLER/ASSEMBLER:
Leave these instructions with consumer.

CONSUMER: Retain this manual for future reference.

⚠ WARNING

This instruction manual contains important information necessary for the proper assembly and safe use of the appliance.

⚠ WARNING

Read all warnings and instructions before assembling the appliance.

Follow all warnings and instructions while using the appliance.

⚠ WARNING

Accessible parts may be very hot. Keep children and pets away from appliance at all times.

This appliance is not intended for use by children.

Close supervision is necessary when any appliance is used by or near children.

⚠ WARNING

This appliance is not intended for and should never be used as a heater.

Do not use for purposes other than intended.

Do not modify this appliance.

⚠ DANGER

Never place any items within 3 in (8 cm) of the cooking surface while in use. This area can become very hot and potentially damage any accessory objects placed too close.

⚠ DANGER

Do not store or use gasoline or other flammable liquids or vapors in the vicinity of this or any other appliance.

Do not store a spare LPG cylinder under or near this appliance.

If these instructions are not followed exactly, a fire causing death or serious injury may occur.

⚠ DANGER

IF YOU SMELL GAS:

1. Shut off gas to appliance.
2. Extinguish any open flame.
3. Open lid.
4. If odor continues, keep away from appliance and immediately call your gas supplier or your fire department.

Failure to follow these instructions could result in fire or explosion which could cause property damage, personal injury or death.

⚠ DANGER

If a fire should occur, keep away from the appliance and immediately call your fire department. **DO NOT** attempt to extinguish an oil or a grease fire with water.

⚠ DANGER

ONLY USE IN WELL-VENTILATED AREAS.

CARBON-MONOXIDE HAZARD - USING THIS APPLIANCE IN AN ENCLOSED SPACE MAY CAUSE DEATH.

⚠ DANGER

- This appliance is for outdoor use only, and is not to be used in a building, garage, or any other enclosed area.
- This appliance is not be used on or under any apartment or condominium balcony or deck.

⚠ DANGER

DO NOT USE THIS APPLIANCE INSIDE OR ON RECREATIONAL VEHICLES, CARAVANS, TENTS, MARINE CRAFT, BOATS, CARS, MOBILE HOMES OR SIMILAR LOCATIONS.



COOKING TIPS

LOW HEAT:

Cooks slowly and requires more time.

Breaks down connective tissue and fat for a tender, moist meal.

- Fatty, thick cuts of meat.
(eg: chuck steak, brisket, chicken thighs, short ribs)
- Delicate seafood
(eg: octopus, squid)

MEDIUM HEAT:

Stable heat, takes the average time you'd expect for pancakes, eggs, toast, and more.

For food more susceptible to heat. Sear without overcooking.

- Fish (whole or in pieces)
- Most seafood
- Vegetables
(steam with the **Blackstone Basting Dome** for best flavor)
- Pancakes
- Eggs

HIGH HEAT:

Cooks meals fast and in little time.

Slow cooking would dry up these cuts and make them horrible to eat since they are lower on fat.

- Lean cuts of meat.
(eg: chicken breast, tenderloin, skirt steak, flank)

This appliance is safety certified for use in the United States and/or Canada only. Do not modify for use in any other location. Modification will result in a safety hazard and void warranty.

VIDEO RECIPES

Learn how to use your new Blackstone with our Blackstone Chefs!

Easily cook thousands of mouth-watering recipes for breakfast, lunch and dinner. From red meat and seafood to vegan and desserts, you can cook anything, anytime, anywhere.



[youtube.com/c/BlackstoneGriddles](https://www.youtube.com/c/BlackstoneGriddles)

⚠ WARNING

This product can expose you to chemicals including Di(2-Ethylhexyl) Phthalate (DEHP), which is known to the State of California to cause cancer and birth defects or other reproductive harm, and Diisononyl Phthalate(DINP), which is known to the State of California to cause cancer. For more information, go to www.P65Warnings.ca.gov.

⚠ WARNING

Fuels used in liquefied propane gas appliances, and the products of combustion of such fuels, can expose you to chemicals including benzene, which is known to the State of California to cause cancer and cause birth defects or other reproductive harm. For more information go to www.P65Warnings.ca.gov.

INSTALLATION SAFETY

Appliance installation must conform with local codes, or in the absence of local codes, with either the National Fuel Gas Code, ANSI Z223.1/ NFPA 54, Natural Gas and Propane Installation Code, CSA B149.1, or Propane Storage and Handling Code, B149.2, or the Standard for Recreational Vehicles, NFPA 1192, and CSA Z240 RV Series, Recreational Vehicle Code, as applicable.



TABLE OF CONTENTS

It is the consumer's responsibility to see that the unit is properly assembled, installed, and maintained. Failure to follow the instructions in this manual could result in bodily injury and/or property damage.

CONTENTS

- 01. REGISTER YOUR PRODUCT 01**
- 02. FOR YOUR SAFETY 02**
 - Section 01. Food Safety 02
 - Section 02. Gas Appliance Safety 03
- 03. ASSEMBLY GUIDE 04**
- 04. FUEL | 1 LB (453 G) PROPANE BOTTLE..... 14**
 - Section 01. LPG Bottle Requirements 14
- 05. IGNITION | PIEZO-ELECTRIC..... 16**
- 06. TROUBLESHOOTING 17**
 - Section 01. Piezo-Electric Ignition 17
 - Section 02. Gas Flow..... 18
- 07. CARE & MAINTENANCE..... 20**
 - Section 01. General Care..... 20
 - Section 02. Cleaning the Burner Assembly 22
 - Section 03. Griddle Seasoning Instructions..... 24
 - Section 04. Cleaning Your Griddle Top 26
- 08. RECIPES..... 28**
- 09. WARRANTY..... 31**

SAFETY ALERT KEY

Read and follow all the notices throughout the manual.

DANGER
Indicates an imminently hazardous situation which, if not avoided, may result in death or serious injury.
WARNING
Indicates the possibility of serious bodily injury if the instructions are not followed.
CAUTION
Indicates a potentially hazardous situation which, if not avoided, may result in minor or moderate injury.



REGISTER YOUR PRODUCT

Registration allows our Customer Service Representatives to quickly provide assistance with your Blackstone product if needed.

The North Atlantic Imports LLC 1-Year Warranty covers replacement parts up to one year after the date of purchase. (Please reference the Warranty chapter for more information.) To enable this warranty, you will need to provide:

- Proof of Purchase/ Receipt/ Order Details
- Your Blackstone product's Serial Number
- Your Blackstone product's Model Number

Your Blackstone product's Serial and Model numbers can be found on your griddle's Origin Label. (The Origin Label is a large silver sticker found on the body of your appliance.)

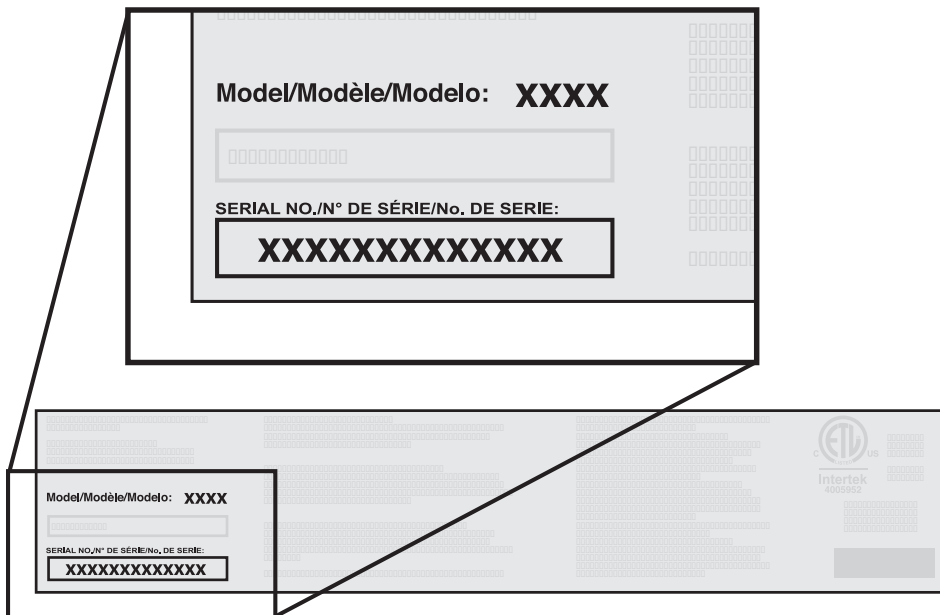

OUR CUSTOMER SERVICE STAFF IS HERE TO HELP YOU!

Register your Blackstone product at **blackstoneproducts.com/register** and visit us online at **blackstoneproducts.com/support**



Model Number _____

Serial Number _____

Date Purchased _____

We are pleased to help you with any questions concerning appliance use, replacement parts, or your warranty.

Customer Service Hours:

Monday - Friday
7:00 am - 5:00 pm (MST)

**⚠ DANGER**

Never operate this appliance unattended.

⚠ WARNING

NEVER partially cook meat or poultry to finish cooking later. Cook food completely to destroy harmful bacteria.

⚠ WARNING

The use of alcohol, prescription or non-prescription drugs may impair the consumer's ability to properly assemble or safely operate the appliance.

⚠ CAUTION

For residential and household use only. **DO NOT** use for commercial cooking.

⚠ CAUTION

Use long-handled cooking utensils and oven mitts to protect against burns and splatters.

⚠ CAUTION

- Do not place any empty cooking or frying vessels on the cooking surface while in operation.
- Use caution when placing anything in cooking vessel while the appliance is in operation.

FOR YOUR SAFETY

Before proceeding, make certain that you understand the FOR YOUR SAFETY section of this manual. Hazardous fire or explosion may result if instructions are ignored.

Section 01

FOOD SAFETY

Food safety is an important part of enjoying the outdoor cooking experience. To keep food safe from harmful bacteria, follow these four basic steps:

CLEAN: Wash hands, utensils, and surfaces with hot soapy water before and after handling raw meat and poultry.

SEPARATE: Separate raw meats and poultry from ready-to eat foods to avoid cross contamination. Use clean platter and utensils when removing cooked foods from appliance.

COOK: Cook meat and poultry thoroughly to kill bacteria. Use thermometer to ensure proper internal food temperatures.

CHILL: Refrigerate prepared foods and leftovers promptly.

For more information visit foodsafety.gov or Canadian Partnership for Consumer Food Safety Education online at befoodsafe.ca

HOW TO TELL IF MEAT IS COOKED THOROUGHLY

Meat and poultry cooked with this appliance often browns very fast on the outside.

Use a meat thermometer to be sure food has reached a safe internal temperature and cut into food to check for visual signs of doneness.

When reheating takeout foods or fully cooked meats like hot dogs, cook to 165° F (74° C), or until steaming hot.

MEAT COOKING TEMPERATURES

🐔 Poultry

165° F or 74° C

Juices should run clear and flesh should not be pink.

🐄 🐔 Beef or Poultry Hamburger

160° F or 71° C

Juices should not be pink and flesh should be brown in the middle.

🐄 🐑 Beef, Veal, & Lamb Steaks/ Chops/ Roasts

145° F or 63° C

🐷 ALL cuts of Pork

160° F or 71° C

Juices should not be pink.



Section 02

GAS APPLIANCE SAFETY

If grease or other hot material drips from appliance onto valve, hose or regulator:

STEP 01 Turn off gas supply immediately.

STEP 02 Determine the cause and correct it.

STEP 03 Clean and inspect valve, hose and regulator before continuing.

STEP 04 Perform a leak test. (Please reference the Leak Test Instructions in the Fuel chapter.)

For problems with this appliance, please reference the Troubleshooting chapter.

GAS INSTALLATION CODES

Appliances must be used in accordance with the installation requirements of your gas supply authority, and constructed and marked in accordance with the applicable standard:

- Specifications for LPG Cylinders of the U.S. Department of Transportation (DOT)
- National Standard of Canada, CAN/CSA-B339, Cylinders, Spheres, and Tubes
- Specifications for LPG cylinders, Transports Canada (TC), Transportation of Dangerous Goods (TDG)
- Australian Standard AS/NZS 5601

See LPG Cylinder collar for marking.

⚠ WARNING

If the appliance is not in use, the gas must be turned off at the supply cylinder.

⚠ WARNING

Storage of an appliance indoors is permissible only if the cylinder is disconnected and removed from the appliance.

The cylinder supply system must be arranged for vapor withdrawal.

⚠ WARNING

Use this appliance, as purchased, only with gas and regulator/valve assembly supplied.

Replacement pressure regulators and hose assemblies shall be those specified by the appliance manufacturer.

⚠ DANGER

When not in use, turn OFF appliance by rotating the appliance control knobs to the OFF position and closing the fuel valve.

If the information in the above statements is not followed exactly, serious injuries, fire, or death may occur.

⚠ DANGER

When cooking with oil or grease, have a type BC or ABC fire extinguisher readily available.

⚠ DANGER

DO NOT operate this appliance any closer than 36 in (1 m) from the sides and back of the appliance. Do not use this appliance under overhead combustible surfaces.

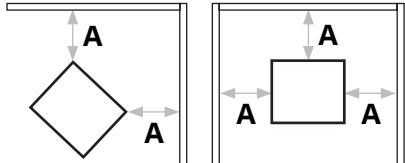

A = 36" (1 m)

⚠ CAUTION





Do not move the appliance when in use. Allow cooking vessel to cool to 115° F (45° C) before moving or storing.

REGULATOR SAFETY

If regulator fails in unit, it must be replaced with a Blackstone approved model and must only be replaced by a professionally licensed, authorized dealer. Failure to comply will void the warranty.

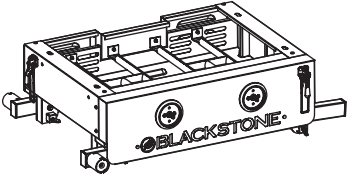

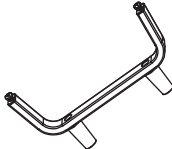
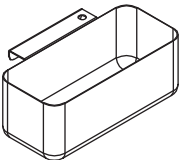
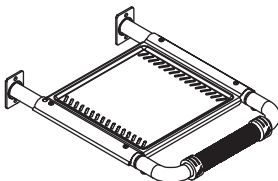
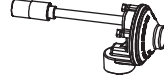
ILLUSTRATED PARTS LIST

<p>1 Body (1 piece)</p> 	<p>2 Griddle top & Hood (1 piece)</p> 	<p>3 Hood handle (1 piece)</p> 	<p>4 Side handle (1 piece)</p> 
<p>5 Grease cup (1 piece)</p> 	<p>6 Side shelf (1 piece)</p> 	<p>7 Regulator (1 piece)</p> 	<p>8 Wheels (2 pieces)</p> 

PARTS	QTY
1.5c Leg caps	4
1.5d Left leg crossbar	1
1.5e Folding crossbar	1
1.5f Ring pin assemblies	5
1.6 Right leg assembly	1
1.7 Ignition needles	2
1.8 H burners	2
1.9 Gas rail	1
2.1 Griddle top	1
2.2 Hood	1
2.3 Hood hinge assembly	2
3.1 Hood handle grommets	2
6.1 Side shelf support bars	2
6.2 Side shelf handle	1

9 Hardware pack (1 piece)

- a.** Control knobs (2 pieces)
- b.** M6x12 bolts (6 pieces)
- c.** Griddle feet (2 pieces)
- d.** M10x17 step bolts and bolt sleeves (2 pieces)

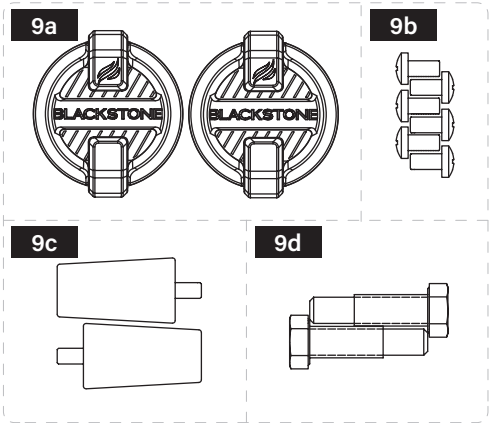
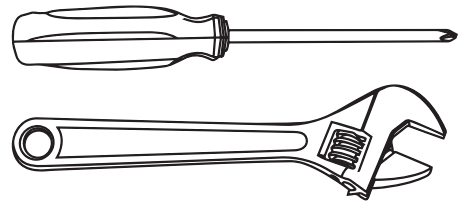
NOT INCLUDED:
1 lb (453 g) LPG bottle

TOOLS NEEDED: Phillips head screwdriver & Adjustable wrench

**⚠ WARNING**

The manufacturer has made every effort to eliminate any sharp edges. However, you should handle all components with care to avoid accidental injury.

Some parts may contain sharp edges, especially as noted in these instructions. Wear protective gloves if necessary.

⚠ CAUTION

Two people are recommended for the assembly of this product.

ENGLISH

ASSEMBLY INSTRUCTIONS

Please read all instructions thoroughly before proceeding. Make sure all the plastic packing material is removed before assembling.

Find a large, clean area to assemble your unit. Please refer to the parts list and assembly diagrams as necessary.

STEP 01 With the help of another person, remove the griddle body from the packaging, and place upside down on a smooth flat surface.

Screw the two (2) griddle feet into the left leg assembly.

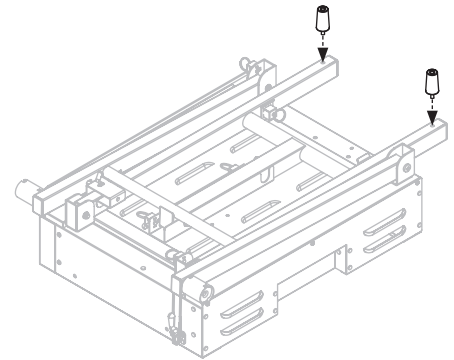

STEP 02 ① Pull the locking pin to unlock the right leg assembly.

② Pull the outer right ring pin, and lift the right leg assembly to its vertical position. (The ring pin will re-engage when the leg assembly is fully open.)

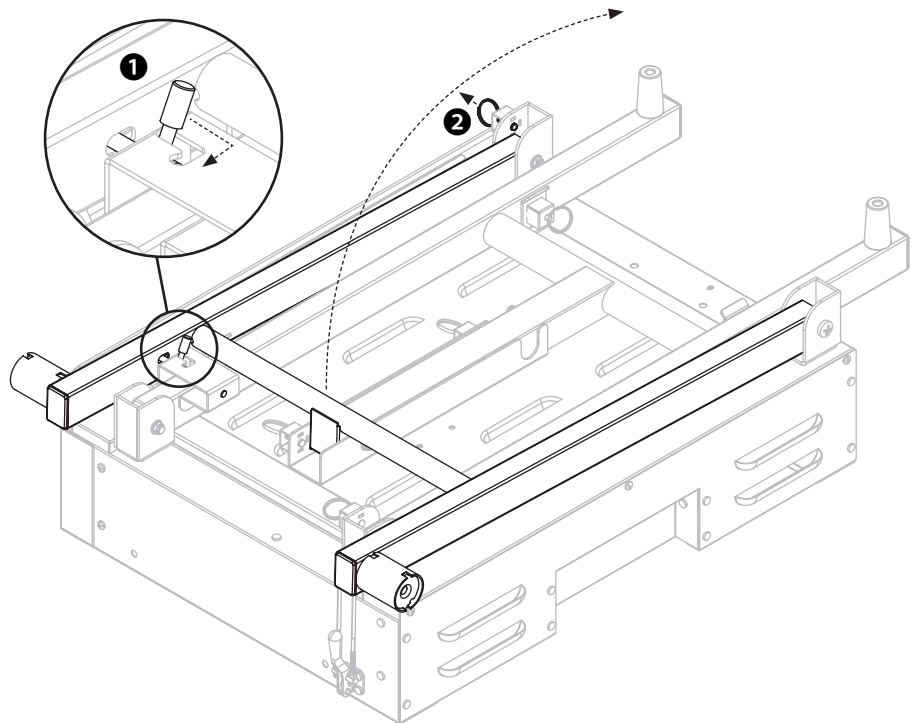



STEP 03 ① Pull the inner right ring pin and lift the left leg assembly slightly before releasing the pin.

② Pull the inner left ring pin, and lift the left leg assembly to its vertical position. (The ring pin will re-engage when the leg assembly is fully open.)

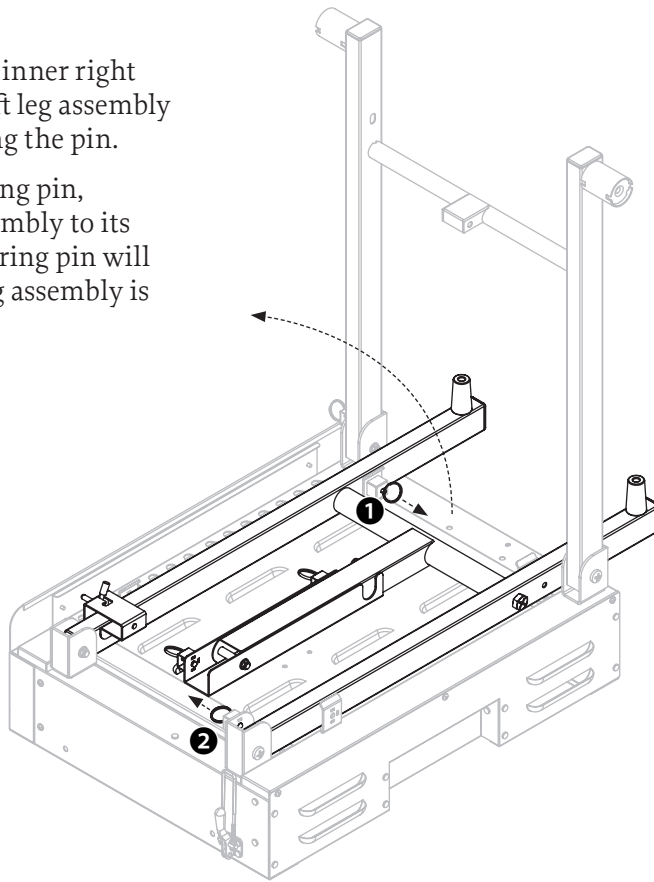

STEP 04 Pull the far ring pin to unfold the crossbar.

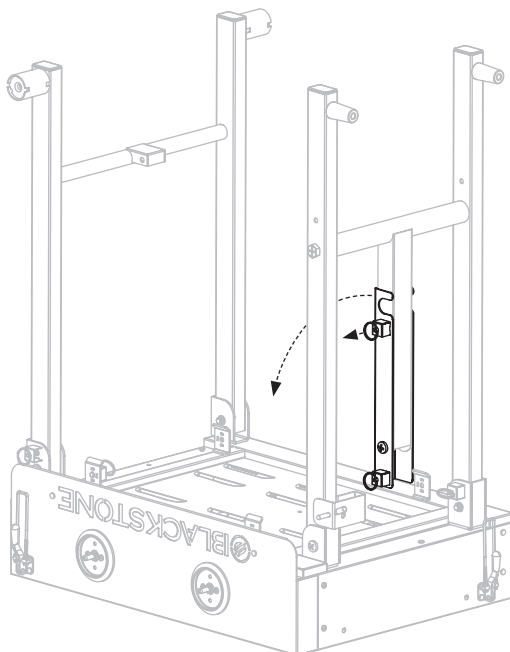



STEP 05 Raise the crossbar.

1 Pull the center ring pin to allow the crossbar to lock into its open position. (The ring pin will re-engage when the crossbar is horizontal.)

2 Pull the far ring pin to allow the crossbar to align with the right leg assembly. (The ring pin will re-engage when the crossbar is aligned properly.)

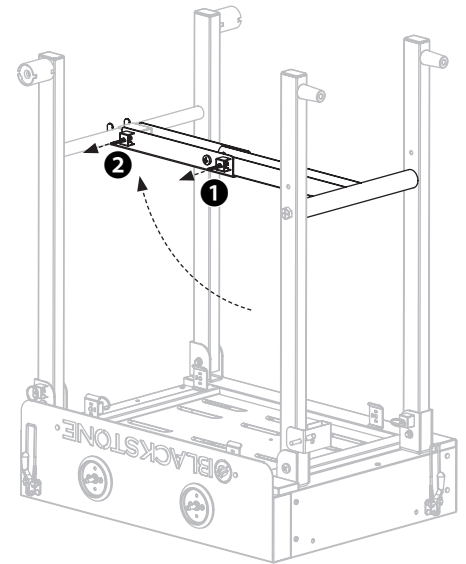

STEP 06 Use two (2) M10x17 step bolts and bolt sleeves to install the two (2) wheels to the right leg assembly.

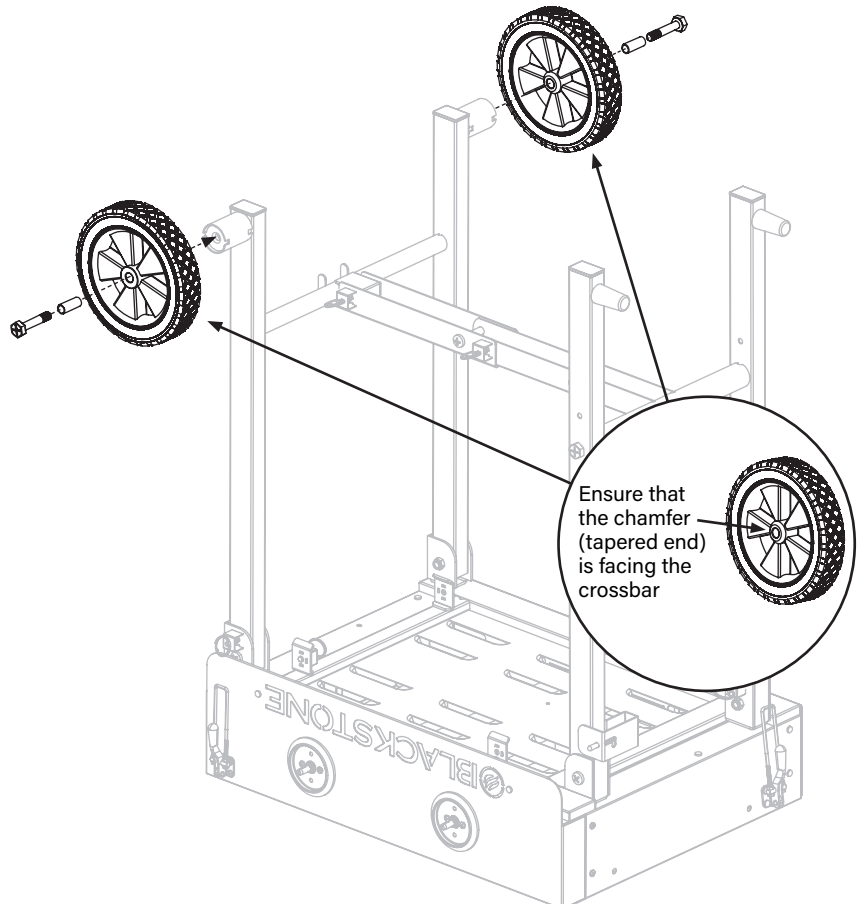



STEP 07 With the help of another person, set the griddle on its feet.

Install the two (2) control knobs by pushing them into place in the OFF position.

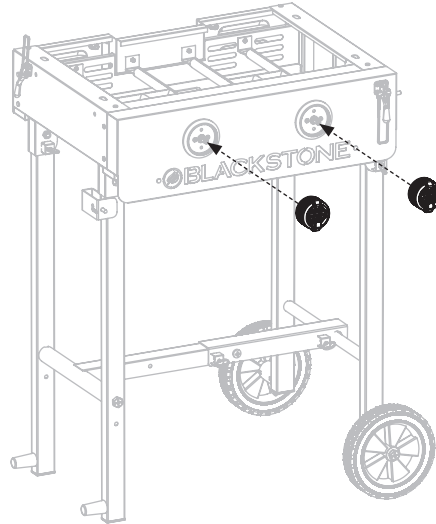

⚠ WARNING

Do not touch the handle while unit is hot.

⚠ CAUTION

- Maximum weight on the side shelf is 10 lbs (4.5 kg).
- The side shelf may get hot while griddle is in use.

STEP 08 Use four (4) M6x12 bolts to attach the side shelf to the right side of the griddle.

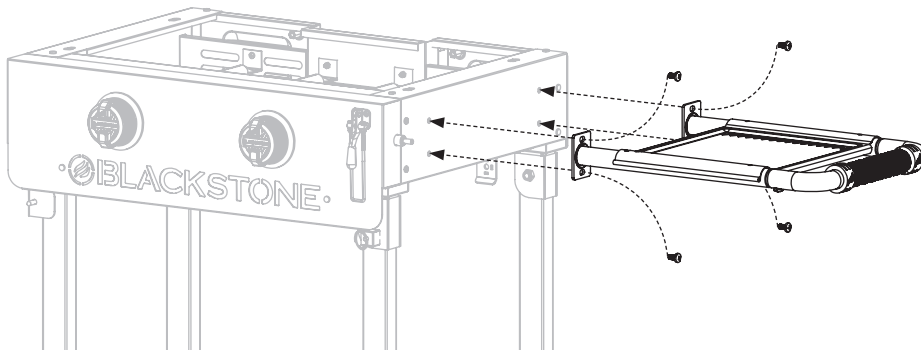

STEP 09 Use the two (2) M6x12 bolts pre-installed in the side handle to attach the side handle to the left side of the griddle.

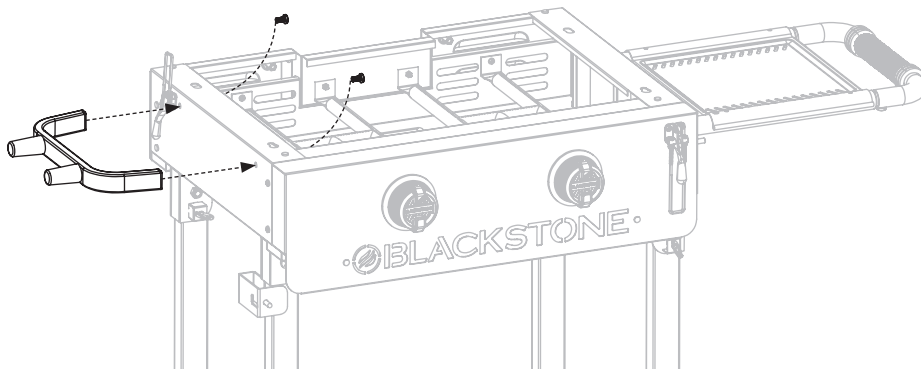

**⚠ WARNING**

Do not leave the hood closed for more than 10 minutes while cooking.

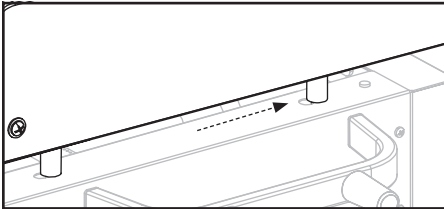

Ensure that the front pins are fully seated in the holes, then push the griddle top forward to lock the griddle in place.

STEP 10 Place the griddle top and hood onto the griddle body by aligning the four pins to the holes of the body. Ensure that the front pins are fully seated in the holes, then push the griddle top forward to lock the griddle in place.

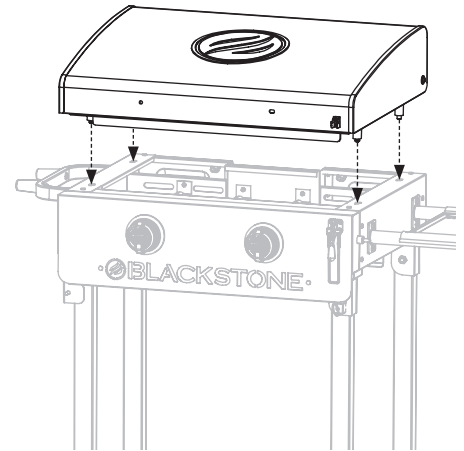

STEP 11 Use two (2) M6x12 bolts to secure the back of the griddle top and hood to the back of the griddle body.

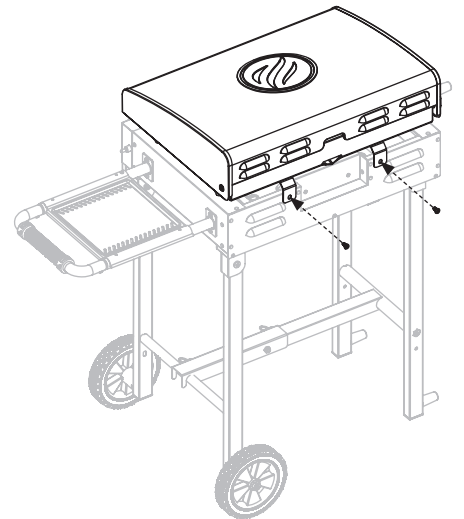

STEP 12 Use the two M6x16 screws pre-installed in the hood handle to attach the hood handle and two (2) hood handle grommets to the hood.

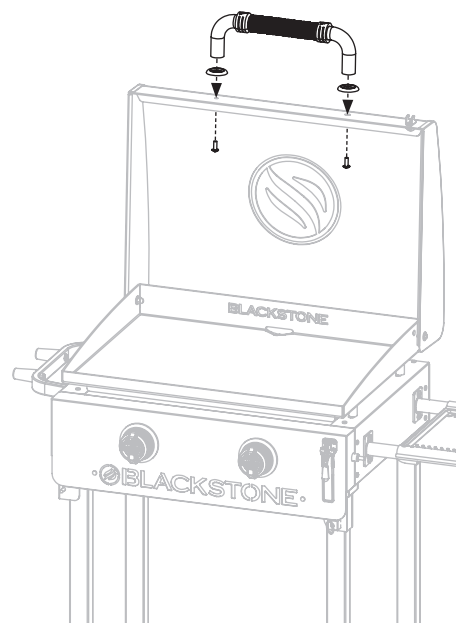



STEP 13 Hang the grease cup on the back of the griddle body.

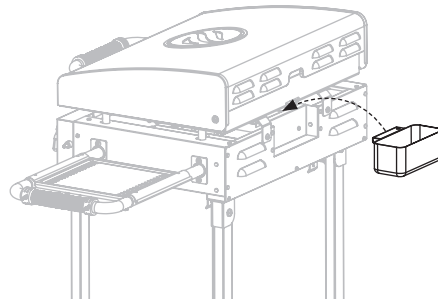

STEP 14 Screw the LP bottle into the gas regulator, turning the tank clockwise.

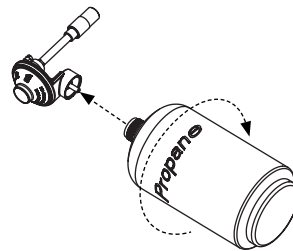

STEP 15 Insert the gas regulator into the fuel line of the griddle. Turn the collar of the gas regulator clockwise to secure it to the fuel line.

(NOTE: Ensure that the propane bottle is angled as shown.)

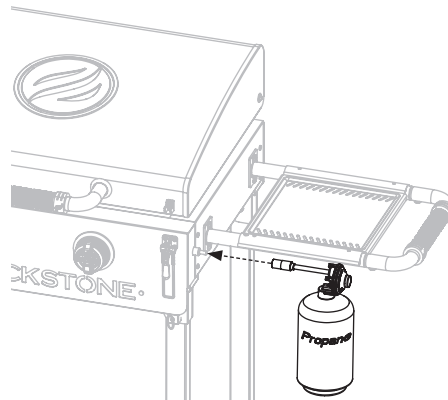

STEP 16 Proceed to the Griddle Seasoning Instructions section of the Care & Maintenance chapter.

Enjoy cooking outdoors on your Blackstone!

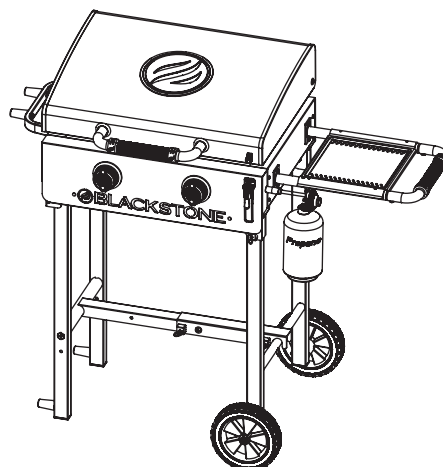

ASSEMBLY VIDEOS

View Product Assembly and Technical Support videos online at blackstoneproducts.com/support and on YouTube @BlackstoneGriddles





FOLDING THE GRIDDLE LEGS FOR TRANSPORT AND STORAGE

STEP 01 Disconnect the LPG bottle, regulator, and grease cup. Ensure that the hood is buckled shut.

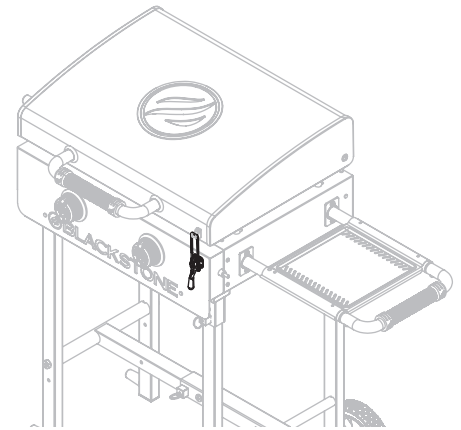

STEP 02 Set the griddle on its side.

❶ Pull the far ring pin to unlock the crossbar from the right leg assembly.

❷ Pull the center ring pin to fold the crossbar.

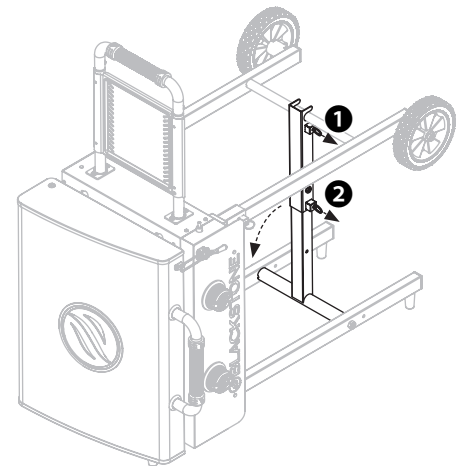

STEP 03 ❶ Pull the far ring pin to lock the crossbar. ❷ Pull the inner left ring pin to fold the left leg assembly.

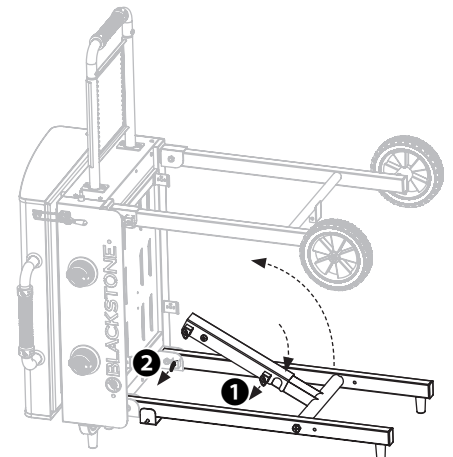



STEP 04 Align the left leg assembly with the inner right ring pin hole.

① Pull and release the inner right ring pin to lock the left leg assembly.

② Pull and release the outer right ring pin to fold the right leg assembly.

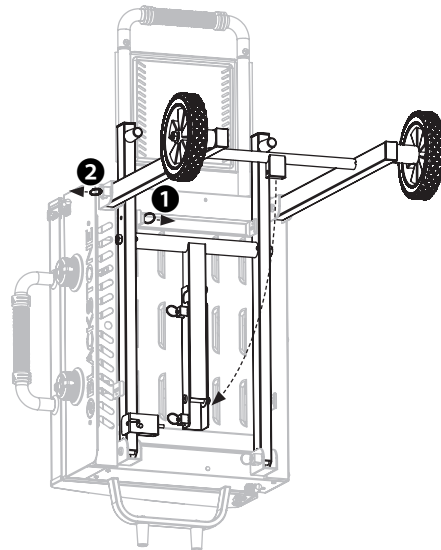

STEP 05 Align the right leg assembly with the locking pin hole. Push the locking pin to lock the right leg assembly.

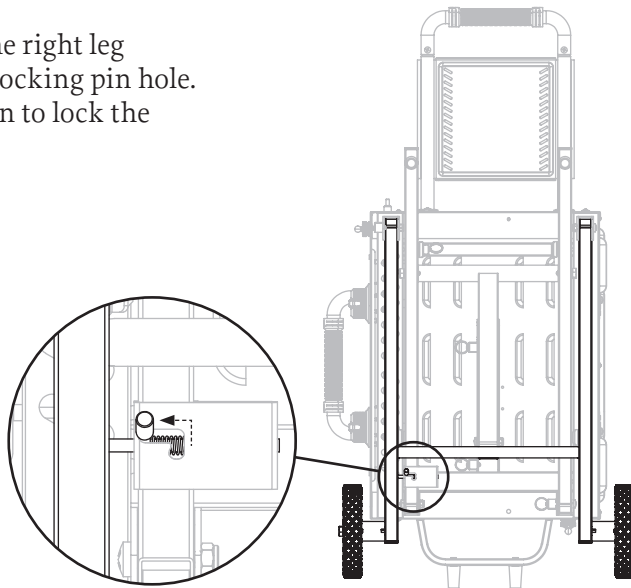

STEP 06 Ready for on the go!

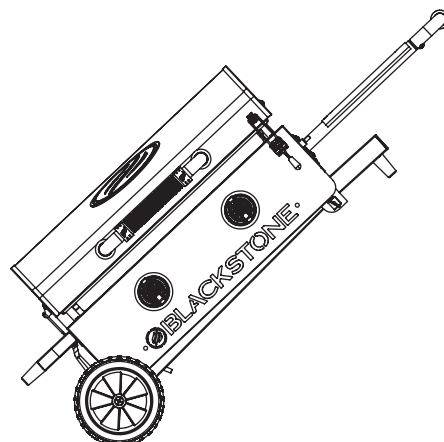

**⚠ DANGER**

DO NOT cross thread the connection between your propane bottle and regulator or regulator and gas rail. Cross threading can occur if you force thread a connection at an improper angle. This will damage the threads, lead to propane leaking, and potentially result in a build-up of fuel that can ignite.

⚠ WARNING

The LPG supply cylinder must be disconnected when this appliance is not in use.

⚠ WARNING

LPG is highly flammable and may ignite unexpectedly when mixed with air.

⚠ CAUTION

LPG is nontoxic, odorless and colorless when produced. For safety and easy detection, LPG has been given an odor similar to rotten cabbage.

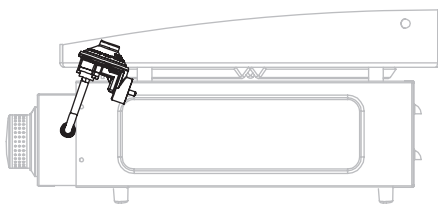

PLEASE NOTE: The gas regulator is intended to be used at an angle towards the rear of the appliance as shown above.

FUEL | 1 LB (453 G) PROPANE BOTTLE

Section 01

LPG BOTTLE REQUIREMENTS

LPG CYLINDER REQUIREMENTS

The LPG Bottle used with your griddle must meet the following requirements:

- Size: 3.8 x 7.8 inches, 1 lb (453 g).

CONNECTING THE LPG BOTTLE

Ensure that the LPG bottle is positioned below the regulator. If the liquid level of the propane is above the regulator, the regulator will frost.

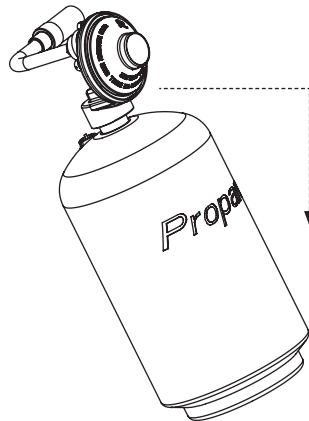

If frosting persists after bottle is angled correctly: Turn off the appliance and disconnect LPG bottle immediately. This indicates a problem with the bottle and it should not be used on any product. **Return bottle to supplier.**

DISCONNECTING THE LPG BOTTLE

STEP 01 Ensure that the control knobs are turned to OFF.

STEP 02 Once the appliance has cooled, disconnect the regulator from the gas line by unscrewing the collar.

STEP 03 Unscrew LPG bottle from the regulator.

- Place dust cap on bottle valve outlet whenever bottle is not in use.
- Only install the type of dust cap on the bottle valve outlet that is provided with bottle valve. Other types of caps or plugs may result in leakage of propane.

**⚠ WARNING**

Do not lean over the appliance while lighting.

⚠ WARNING

If ignition does NOT occur in 5 seconds, turn burner controls OFF, wait 5 minutes and repeat lighting procedure.

If burner does not ignite with open valve, gas will continue to flow out of burner and could accidentally/inadvertently ignite with risk of injury.

IGNITION | PIEZO-ELECTRIC

PROPANE BURNER OPERATION

For proper ignition and operation of the appliance follow the steps below.

STEP 01 Ensure that the gas regulator is angled towards the rear of the appliance, and that the LPG bottle is positioned below the regulator.

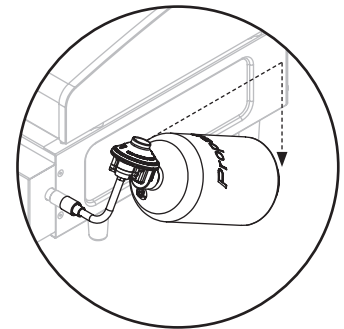
**STEP 02**

- ➊ Push the control knob in to start gas flowing.
- ➋ Turn the control knob counter-clockwise to activate the starter.
- ➌ Adjust the temperature to desired level.

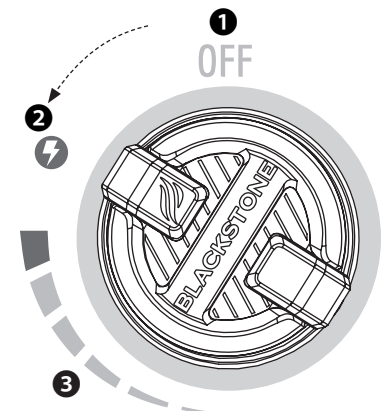



TROUBLESHOOTING

Visit BLACKSTONEPRODUCTS.COM/SUPPORT for additional troubleshooting.

Section 01

PIEZO-ELECTRIC IGNITION

SYMPTOMS

01. Burner will not ignite with piezo ignition system

If ignition does not occur in 5 seconds, turn the burner controls off, wait 5 minutes and repeat the lighting procedure.

If this does not work, to determine the cause, please try to ignite your appliance with a match. (Please reference the Match Lighting Instructions in the Cleaning the Burner Assembly section of the Care & Maintenance chapter.)

If you CAN ignite your appliance with a match

POSSIBLE CAUSES	SOLUTION
01. Ignitor wire misaligned.	Ensure that the ignition needle is positioned 1/8" to 1/4" away from the burner tube, positioned above a burner hole.
02. Damage to the ignition system.	Contact customer service for replacement parts.

If you CAN NOT ignite your appliance with a match

POSSIBLE CAUSES	SOLUTION
03. Burner tubes are not receiving propane.	Please reference the Gas Flow section of the Troubleshooting Chapter.

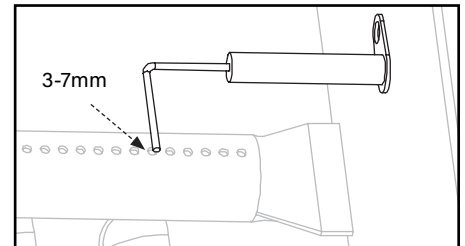

Ensure that the ignition needle is positioned 3-7mm away from the burner tube, positioned above a burner hole.



Section 02 GAS FLOW

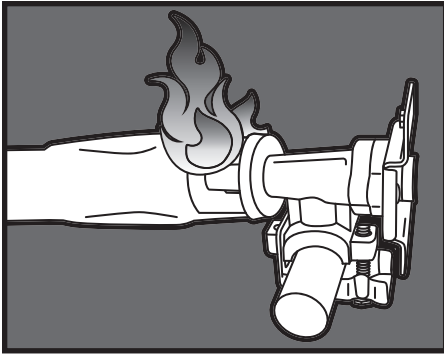

SYMPTOMS

- 01. A flame is coming out of the air gate.

POSSIBLE CAUSES

- 01. Something is blocking the venturi in the burner tube. This is not allowing the propane to flow through the burner, causing the flame to back out the air gate.

SOLUTION

Clean the burner assembly to remove the obstruction. (Please reference the Cleaning the Burner Assembly section of the Care & Maintenance chapter.)

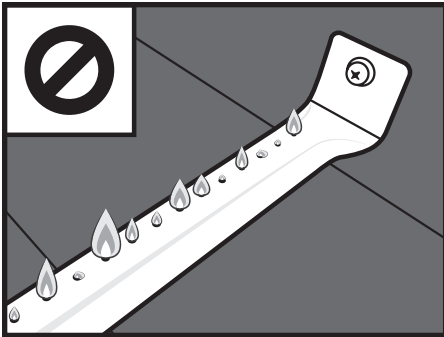

SYMPTOMS

- 01. Burner flames are yellow or irregular.

POSSIBLE CAUSES

- 01. Something is blocking the air gate for the burner. This is blocking oxygen from mixing with the propane correctly to get healthy flames.

SOLUTION

Check the air gates in your burner. If you have adjustable air shutters over your air gates, make sure that they are completely open. If your burners have bug shields, clean any spider webs, soot, or debris off the bug shield. Clean any other obstructions out of air gates.

TECHNICAL SUPPORT:

Scan QR code for more videos or visit the Blackstone YouTube channel at youtube.com/blackstonegriddles

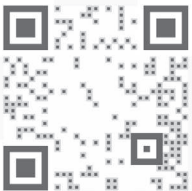



SYMPTOMS

- 01. Appliance will not achieve a high heat or heats unevenly.
- 02. Burner flames start strong, then immediately drop to low even when burner is set to high position.
- 03. Flame height drops when a second burner is lit.
- 04. Flames do not extend the full length of the burner, or only run on one side of the burner.
- 05. Burner flames are inconsistent.

POSSIBLE CAUSES

SOLUTION

01. LPG cylinder is empty or low.	Refill or replace the propane tank.
02. Obstructions in the burner, gas jets, or fuel rail.	Clean the burner, jets, and gas hose. (Please reference the Cleaning the Burner Assembly section of the Care & Maintenance chapter.)
03. United States regulations require that all regulators contain a flow limiting device for consumer safety. This device measures the amount of propane going through the regulator to ensure the levels are safe. If the flow rate through the regulator is too high (a symptom of a large leak), the flow limiting device will trigger, restricting the flow of propane to reduce the chance of a dangerous fire. This safety system can accidentally be tripped by opening a propane tank too quickly or opening the propane tank when a burner knob is not in the off position.	<p>This safety system can be reset by:</p> <p>Moving the burner knobs to the off position, closing the propane tank, and disconnecting the regulator from the propane tank.</p> <p>Wait five minutes to allow the pressure to dissipate, then reconnect the regulator to the propane tank and slowly open the OPD handwheel one half turn.</p> <p>Ignite your appliance as described in the Ignition chapter.</p>
04. Regulator stuck in safety position.	Contact customer service for replacement parts.

BURNER FLAME PATTERN

Your appliance's burners are designed to mix oxygen and propane at a rate that allows for optimal flames. Should the burner's holes, air gate, or venturi get blocked, it will affect the propane and air mixture, causing low or inconsistent flames, or flames coming from the air gate.

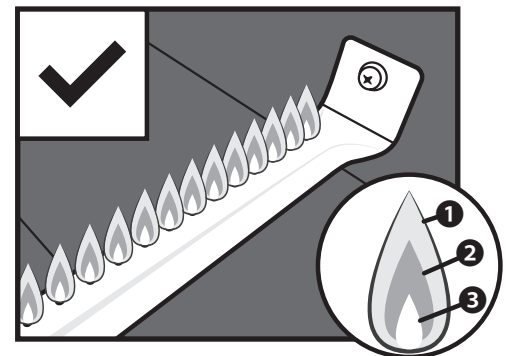

Healthy flames might have a few flickers of yellow color ①, then a dark blue color ②, followed by a vibrant blue by the burner tube ③.

**⚠ WARNING**

When not in use, turn unit controls and gas source OFF.

⚠ WARNING

The appliance must be isolated from the gas supply piping system by closing its individual manual shutoff valve during any pressure testing of the gas supply piping system at test pressures equal to or less than 1/2 psi (3.5 kPa).

⚠ WARNING

This appliance will be hot during and after use. Use insulated oven mitts or gloves for protection from hot surfaces or splatter from cooking liquids.

⚠ CAUTION

NEVER handle hot parts with unprotected hands.

⚠ CAUTION

DO NOT use Citrisol, abrasive cleaners, de-greasers or a concentrated cleaner on plastic parts. **Damage to and failure of parts may result.**

CARE & MAINTENANCE

Regularly clean your appliance between uses, especially after extended periods of storage. In order to extend the life and condition of unit, follow best practices detailed in this manual.

Section 01

GENERAL CARE

GENERAL CLEANING

Ensure that the appliance and its components are sufficiently cool before cleaning.

- Clean your appliance often, preferably after each use.
- Be sure to keep the ventilation opening(s) of the cylinder enclosure free and clear from debris.
- Baked-on grease deposits may require the use of an abrasive plastic cleaning pad. Use only in direction of brushed finish to avoid damage.
- DO NOT use abrasive pad on areas with graphics.
- If a bristle brush is used to clean any of the cooking surfaces, ensure no loose bristles remain on cooking surfaces prior to cooking.

PLASTIC PARTS: Wash with warm soapy water and wipe dry.

PAINTED SURFACES: Wash with mild detergent or nonabrasive cleaner and warm soapy water. Wipe dry with soft nonabrasive cloth.

STAINLESS STEEL SURFACES: To maintain appliance frame's high quality appearance, wash with mild detergent and warm soapy water. Wipe dry with a soft cloth after each use.

AFTER EACH USE

Ensure that any part of the appliance that gets hot and experiences grease build up is cleaned before next use. Otherwise, a fire could occur.



STORAGE

- In order to extend and maintain the life and condition of your appliance, we strongly recommend that the unit be covered when left outside for any length of time, especially during the winter months.
- Take care to always completely dry your appliance before storing and keep away from rain and sprinklers.
- Cover the burners with aluminum foil in order to prevent insects or other debris from collecting in the burner holes.
- When gas supply is connected to appliance, store appliance outdoors in a well-ventilated space and out of reach of children.
- Store appliance indoors **ONLY** if gas supply is turned off, disconnected, removed from appliance and stored outdoors.
- When removing appliance from storage, clean burner assembly before starting appliance. (Please reference the Cleaning the Burner Assembly section.)

VALVE CHECK

Ensure gas is off at the supply shut off valve before checking appliance valves. Knobs must be turned to OFF position.

STEP 01 To check valves, push in knobs and release. Knobs should spring back.

If knobs do not spring back, replace valve assembly before using appliance.

STEP 02 Rotate knobs to LOW position then turn back to OFF position. Knobs should turn smoothly.

COVER FIT GUIDE

Visit us online at
blackstoneproducts.com/support
to find a cover that will fit your appliance.





WARNING

Ensure that the fuel nozzle is housed within the burner opening.

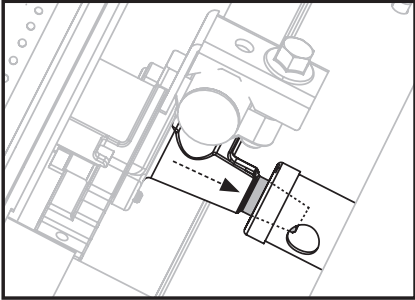

Section 02

CLEANING THE BURNER ASSEMBLY

Unit burners vary, however these instructions apply to all units. Clean burner assembly and check burner for damage. If any large cracks or holes are found, replace burner.

STEP 01 Ensure that the gas is turned OFF at control knobs and gas supply. Remove the cooking top.

STEP 02 Carefully detach and remove the burner.



STEP 03 Run a narrow bottle brush through each burner tube several times. (DO NOT use wire brushes)

Additional Methods Include:

- a** Run a stiff wire bent into a small hook through each burner tube several times.
- b** Use an air hose to force air into burner tube and out burner ports. Check that air blows through each hole. (Wear eye protection)



VIDEO TUTORIAL

How to Clean Your Burner Tube | Blackstone Griddle



youtube.com/watch?v=xKQTCrFCzf8



STEP 04 Brush entire outer surface of burner to remove grime.



STEP 05 Clean any blocked ports with stiff wire such as an open paper clip. Then, carefully replace burners and reattach.

VERY IMPORTANT: Burner tubes must be reengaged with the valve openings.





BURNER MAINTENANCE

In most circumstances, burning residue off after cooking will keep burner clean.

- Ensure that the flow of combustion and ventilation air is not obstructed.
- Burner should be removed and cleaned annually or whenever heavy build-up or insects/insect nests are found in order to ensure that there is no blockage in the burner portholes or venturi tubes.
- Use pipe cleaner to clear obstructions. A wire brush may be used to remove corrosion from the burner surfaces.

MATCH LIGHTING INSTRUCTIONS

Before beginning, check for gas leaks. (Please reference the Leak Test Instructions in the Fuel chapter.)

STEP 01 Ensure control knob is in OFF position.

STEP 02 Remove cooking top.

STEP 03 Light a match (or long lighter) no shorter than 11 inches long. Place the flame on the right or left side of the burner.

STEP 04 Push in and turn the control knob to the HIGH position. Ensure burner lights and stays lit.

BURNER FLAME CHECK

Always check burner flame before use.

STEP 01 Light burners and rotate knobs from high to low. When knob is at high, flames should be larger than when knob is at low.

STEP 02 Perform burner flame check by looking below cooking top on the side of unit to view burners below.

If there is a sudden drop or low flame issue, please reference the Troubleshooting chapter.

⚠ WARNING

A clogged burner tube can lead to a fire beneath the appliance.

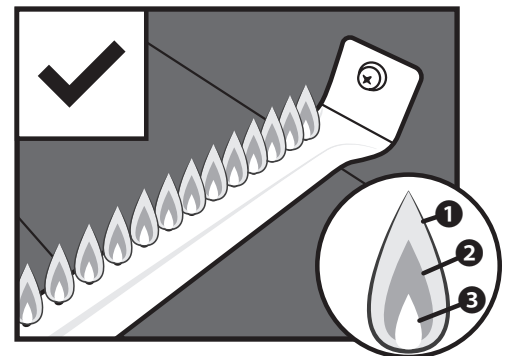
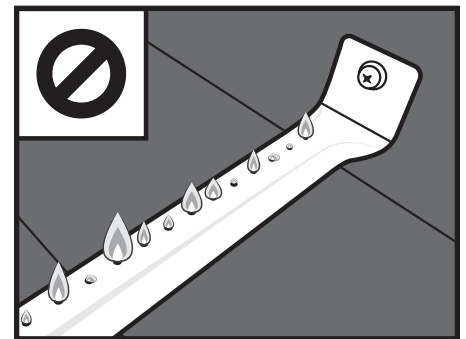

Healthy flames might have a few flickers of yellow color **1**, then a dark blue color **2**, followed by a vibrant blue by the burner tube **3**.



VIDEO TUTORIAL

How to Season a New Blackstone Griddle | Blackstone Griddle



[youtube.com/watch?v=VspmDVnj2pl&t=3s](https://www.youtube.com/watch?v=VspmDVnj2pl&t=3s)



PLEASE NOTE: Small variations in manufacturing and raw materials can cause some griddles to be slightly warped. A slight warp will disappear when the griddle is heated in preparation for cooking.

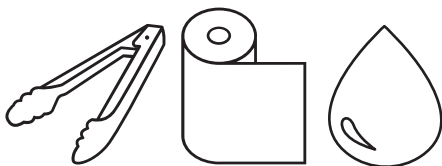

TOOLS NEEDED: Cooking tongs, Paper towels, and Cooking oil

Section 03

GRIDDLE SEASONING INSTRUCTIONS

For best results, we recommended seasoning the griddle before cooking on griddle top.

STEP 01 Make sure griddle top is wiped clean of debris. (For first time cleaning, please reference the Cleaning Your Griddle Top section.)

Blackstone griddle tops are pre-treated with soy oil as a protective coating. This coating may leave a discoloration on the griddle top. This is normal and will not affect the seasoning process.

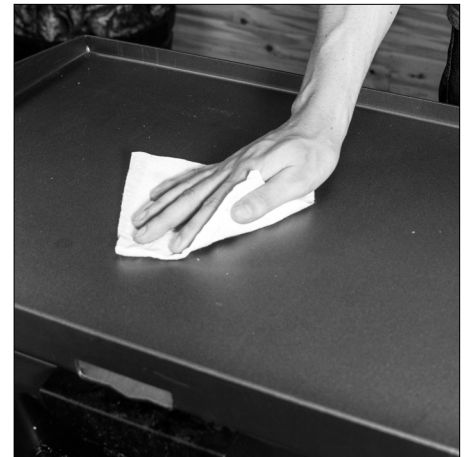

STEP 02 Set your griddle to high heat until your griddle top changes color. Use tongs to hold a paper towel or cotton cloth and spread 2-3 tablespoons of your seasoning oil across the griddle surface.

When seasoning your griddle top, remember to use a thin and even layer of oil—the thinner the layer of oil, the easier it will be to burn it off.

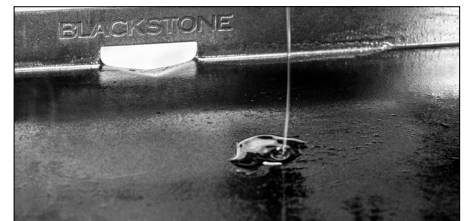

STEP 03 You will know it is done when it stops smoking. You will want to repeat this 3-4 times for your initial seasoning.

The heat of the griddle will break down the oil and bond it to the metal, creating a new polymer that acts as a stick resistant and protective layer over the griddle.





WHY DO I NEED TO SEASON MY GRIDDLE?

Seasoning leaves a hard protective layer bonded to the steel surface.

- Natural stick resistance.
- Prevents rust and corrosion.



⚠ CAUTION

Customers in humid or coastal climates may require more frequent seasonings and the use of heavier cooking oils to avoid rusting and corrosion.

GRIDDLE SEASONING TROUBLESHOOTING

SYMPTOMS

01. After seasoning, there is a brownish residue on the griddle surface.

POSSIBLE CAUSES

01. Too much oil was used.
02. You turned off the heat too soon.

SOLUTION

First, turn your griddle on high and let it heat for 10-15 minutes.

Next, scrape off as much of the thickened and partially cooked oil as you can. Then, re-season with a very thin layer of oil.

SYMPTOMS

01. After seasoning, the griddle surface is not black.
02. Food is sticking to the griddle surface.

POSSIBLE CAUSES

01. The corners and edges do not have the same access to the direct heat of the burners, making it harder for the seasoning to darken like the rest of the griddle top.

SOLUTION

Apply a thin layer of oil between cooks to maintain seasoned cooking surface. (Please reference the Cleaning your Griddle Top section.)

After using your griddle for multiple cooks, the seasoning will even out and improve.

For further troubleshooting, please reference the Troubleshooting chapter.

For Frequently asked questions, visit blackstoneproducts.com/faq

WHAT OIL IS BEST TO USE?

The **Blackstone Seasoning and Cast Iron Conditioner** is the best and easiest way to get consistent results. This unique blend of oils combines the best of many different cooking oils.



Can I use any food grade oil?

Yes, but different oils can vary in the process from the burn time, smoke point, and durability once finished.

If you prefer to use an animal fat for seasoning, only use rendered fat (pure tallow, schmaltz, etc.) with no additives.



⚠ DANGER

DO NOT place flammable items on side shelves near the griddle. Aerosol containers are particularly hazardous because **they can overheat and result in an explosion, fire, severe personal injury, or death.**

⚠ WARNING

DO NOT place oily or greasy towels near the griddle unit as they can spontaneously combust.

⚠ CAUTION

The grease cup must be removed and emptied after each use.

Do not remove the grease cup until the griddle has completely cooled.

ENGLISH

Section 04

CLEANING YOUR GRIDDLE TOP

Follow these simple cleaning steps to ensure optimal performance and longevity of your Blackstone Griddle.

STEP 01 To clean griddle after each use, cool griddle below 300° F. Scrape food debris with spatula or straight metal scraper.



STEP 02 Wipe down griddle surface with paper towel.



STEP 03 Divide griddle surface into approximately 6" sections (width of scraper tool). Apply a small amount of water onto first section with a bottle and then scrape the water and debris toward the grease trap. Move to the next 6" section and repeat.



DO NOT USE MORE THAN TWO TABLESPOONS OF WATER AT A TIME.

(For stuck-on food residue, use a bit of coarse salt.)

STEP 04 Wipe again with a paper towel and dry completely.



STEP 05 Apply thin coat of cooking oil to maintain seasoning and protect the griddle top.

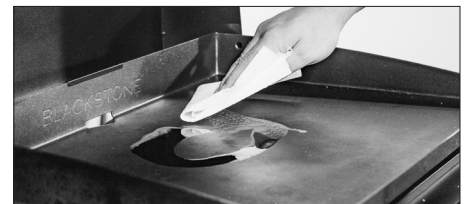

FOR EVERY GRIDDLE SURFACE

The **Blackstone Griddle Degreaser and Cleaning Spray** is gentle enough to clean every surface of your griddle. Use it on the griddle top, the griddle frame, or anywhere that experiences a build up of grease.





FIRST TIME CLEANING

Blackstone Griddles are pre-treated with cooking oil to prevent rust and damage during shipping. For first time use, wash griddle with hot, soapy water.

THIS IS THE ONLY TIME YOU SHOULD USE SOAP ON THE GRIDDLE COOKING SURFACE.

Rinse and dry completely. Proceed with seasoning instructions. (Please reference the Griddle Seasoning Instructions section.)

PROTECTING YOUR GRIDDLE TOP

Store griddle in a cool, dry location. Always cover griddle if stored outdoors. Choose from a variety of griddle covers offered by Blackstone.

When protecting griddle with soft cover, use the “tenting” method to prevent water from accumulating on griddle top. “Tenting” involves placing an object (a bowl, tennis ball or PVC pipe) beneath soft cover in the center of griddle in order to allow water to slide off. “Tenting” helps prevent rust.

CUTTING ON THE GRIDDLE TOP

Using a knife directly on the surface of the griddle will not harm the griddle top.

REMOVING RUST

If rust appears on the griddle surface, rub it off with steel wool, low grit sandpaper or the **Blackstone Pumice Stone** and re-season the surface.

Recovering your Blackstone Griddle Top



[youtube.com/watch?v=thPE2lgnSil](https://www.youtube.com/watch?v=thPE2lgnSil)

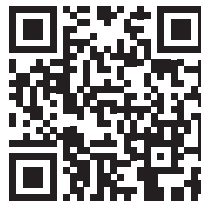

⚠ **WARNING**

NEVER APPLY COLD WATER ACROSS THE WHOLE SURFACE OF A HOT GRIDDLE AT ONCE. This may cause warping.

Adding a large amount of cold or frozen food (or food with significant water content) to a hot griddle may cause griddle to warp.

⚠ **CAUTION**

DO NOT USE SOAP ON THE GRIDDLE COOKING SURFACE. This will destroy the griddle's seasoning.

ASSEMBLY VIDEOS
View Product Assembly and Technical Support videos online at blackstoneproducts.com/support and on YouTube [@BlackstoneGriddles](https://www.youtube.com/@BlackstoneGriddles)





RECIPES FOR LUNCH & DINNER

TACOS BORRACHOS

🍴 Serves 4 | **🕒** 2 - 4 hours

Ingredients

- 12 oz of blond beer
- 2 lb of sirloin steak
- 1 bunch cilantro (finely chopped)
- 1/4 white onion (finely chopped)
- 1/4 tablespoon of black pepper
- 4 garlic cloves (chopped in big chunks)
- 1/4 cup of vegetable oil
- 24 tortillas (small, 4.5" tortillas)
- Salt (to taste)

STEP 01 Season the sirloin steaks with salt and black pepper, making sure that you rub the salt and pepper well into the steaks.

STEP 02 Slice the steak into small pieces.

STEP 03 In a plastic bag, place the steak pieces, onions, garlic, and cilantro. Mix all ingredients together.

STEP 04 Once all ingredients are mixed, add little by little the content of the bottle of beer (cold or room temperature) into the plastic bag.

STEP 05 Take the air out of the plastic bag and let the meat marinate in the refrigerator between 2 and 4 hours.

STEP 06 When the meat is ready, drain the beer and place the meat on a plate.

STEP 07 Pre-heat the Blackstone griddle at medium heat for five minutes. Then, add vegetable oil to the surface and let it get to temperature for thirty seconds. Add your previously marinated steak to the Blackstone griddle.

STEP 08 Cook the steak for about three minutes or until the steak is thoroughly cooked, and place in a bowl.

STEP 09 Spread all remaining steak juices in the griddle, and place the tortillas on top until the tortillas are cooked (the tortillas change color slightly and they become malleable), turning the tortillas from time to time.

STEP 10 To make the tacos, place one tortilla on top of the other (two tortillas together). With a spoon place the steak on top of the tortillas and garnish with white finely chopped onion and cilantro. You can also add your favorite salsa as well.



RECIPES FOR BREAKFAST

STRAWBERRIES AND CREAM PANCAKES

Recipe by Danielle Zechmann



STEP 01 Separate egg and whisk egg white until stiff peaks form. Set aside.

STEP 02 Make your cream cheese filling. Whisk together cream cheese, sugar, and lemon juice. Then, turn to low speed and add in whipped cream. Set aside.

STEP 03 Get your strawberry syrup started. In a sauce pan add chopped strawberries, sugar, lemon juice and simmer on the griddle top or side burner until juices have slightly thickened. (About 20-25 mins.)

STEP 04 In a mixing bowl, combine all dry pancake ingredients.

STEP 05 In a separate bowl, mix egg yolk, milk, lemon juice, ricotta, butter, and vanilla.

STEP 06 Slowly add dry ingredients and mix until combined.

STEP 07 Gently fold the egg whites and strawberry bits into the pancake mix.

STEP 08 Preheat Griddle to medium. Melt a tablespoon of butter on griddle and spread around. Pour 1/4 cup of pancake mix onto griddle and let cook until bubbles start to form and edges are slightly browned. About 3-4 minutes. Flip and cook another 3 minutes.

STEP 09 Once all of your pancakes are cooked, grab a plate and start layering your pancakes. Begin with a pancake, then spread some of the cream cheese filling, and top with the strawberry syrup.

Cream Cheese Filling

- 8 oz cream cheese, room temperature
- 3 tbsp sugar
- 2 tbsp lemon juice
- 2/3 cup whipping cream

Strawberry Syrup

- 1 pint of strawberries cut into chunks (frozen is okay)
- 1/4 cup sugar
- 2 tbsp lemon juice

🍴 Serves 6 | ⌚ 45 min.

Pancake Ingredients

- 1 egg, separated
- 1/2 cup milk
- 1/3 cup ricotta cheese
- 2 tbsp melted butter
- 1 tsp pure vanilla extract
- 2 tsp lemon juice
- 5 strawberries chopped into bits (frozen is okay)

DRY INGREDIENTS

- 2/3 cup all purpose flour
- 2 tsp baking powder
- 1 tbsp sugar
- a pinch of salt

VIDEO RECIPES:

Find more inspiration and recipes at



blackstoneproducts.com/blogs/recipes



youtube.com/c/BlackstoneGriddles



@blackstoneproducts

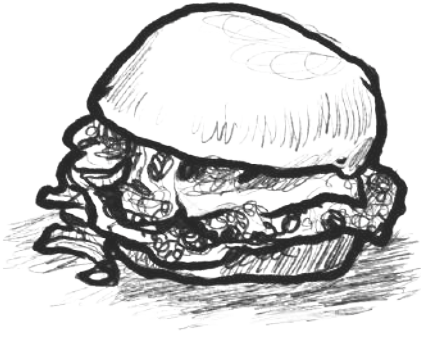

RECIPES FOR LUNCH & DINNER

OKLAHOMA FRIED ONION BURGER

Serves 4 | 7 min.

Ingredients

- 1/2 lb of 80/20 ground beef
- 1 Vidalia (or sweet) onion (sliced paper thin)
- 4 slices American cheese
- 1/4 cup of dill pickle chips
- Salt

STEP 01 Pre-heat your Blackstone to high heat.

STEP 02 Make four (4) 2 oz loosely packed meatballs with the ground beef and place on the hot griddle. Add a pinch of salt over each and using your **Blackstone Burger Press**, smash them very thin.

STEP 03 Add 2-3 ounces of thinly sliced onion over each patty.

STEP 04 Cook for 60-90 seconds and flip so that the onions are under the patty. Add 1 slice of American cheese to each patty and then place the top bun over the cheese and then the bottom bun on top of the top bun. Cook for another 60 seconds.

STEP 05 To plate, remove the bottom bun from the top and set on plate. Use your spatula to lift the burger with top bun and add to the bottom bun.

STEP 06 Serve hot with a few dill pickle chips.

VIDEO RECIPES:

Find more inspiration and recipes at



[blackstoneproducts.com/
blogs/recipes](https://blackstoneproducts.com/blogs/recipes)



[youtube.com/c/
BlackstoneGriddles](https://youtube.com/c/BlackstoneGriddles)



[@blackstoneproducts](https://blackstoneproducts.com)



NORTH ATLANTIC IMPORTS LLC 1-YEAR WARRANTY

North Atlantic Imports, the manufacturer, will warranty for one year from purchase all parts, workmanship, and finishes. It will be the manufacturer's option as to whether to repair or replace any of the above items. All warranties are limited to the original purchaser only. This warranty does not cover any liability on the part of North Atlantic Imports, its agents or employees, for any indirect or consequential damages for breach of warranty. The purchaser must follow the manufacturer's usage instructions.

Under no circumstances is the manufacturer responsible for damages from the failure to operate the cooking station properly. It is the responsibility of the purchaser to establish the warranty period by verifying the original purchase date with original sales receipt.

For more detailed explanation of the warranty, read below:

North Atlantic Imports LLC warrants to the owner that the product covered by this agreement is free from defects in material and workmanship under normal use and service for which it was intended if, but only if, it has been operated in accordance with North Atlantic Imports LLC instructions exclusively for domestic use, and not for private or public club, institutional or commercial purposes.

North Atlantic Imports LLC's obligation under this warranty is limited to replacing or repairing, free of charge, any part or parts that may prove, to the satisfaction of North Atlantic Imports LLC, to be defective under normal home use and service within the following stated periods of time from the date of purchase; for one year from purchase, all parts, finish, and workmanship. Should any failure to conform to this warranty become apparent during applicable warranty periods stated above, the original purchaser must notify North Atlantic Imports LLC of breach of warranty within the applicable warranty period.

North Atlantic Imports LLC shall upon notice and compliance by the original purchaser with such instructions, correct such nonconformity by repair or replacement of the defective part or parts.

Correction in the manner provided above shall constitute a fulfillment of all obligations of North Atlantic Imports LLC with respect to the quality of the product.

North Atlantic Imports LLC does not warrant this equipment to meet the requirement of any safety code of any state, municipality or other jurisdiction, and the original purchaser assumes all risk and liability whatsoever resulting from the use thereof, whether used in accordance with North Atlantic Imports LLC instructions or otherwise.

This warranty does not cover and is intended to exclude any liability on the part of North Atlantic its agents, servants or employees whether under this warranty or implied by law for any indirect or consequential damages for breach on any warranty. The purchaser must

establish all applicable warranty periods pursuant to this warranty by verifying the original purchase date by producing the dated sales receipt. This warranty shall not apply to this product or any other part thereof which has been subject to accident, negligence, alteration, abuse, or misuse or which has been repaired or altered without North Atlantic written consent, outside of North Atlantic Imports LLC factory. The full manufacturer warranty is not valid for griddles purchased from unlicensed, third-party resellers, purchased at a discount due to missing or damaged parts, or purchased as a floor model; at the discretion of North Atlantic Imports.

North Atlantic Imports LLC makes no warranty whatsoever in respect to accessories or parts not supplied with it. This warranty shall apply only within the boundaries of the United States of America. This warranty gives the original purchaser specific rights, and the original purchaser may also have other rights, which vary from state to state.

