



OWNER'S MANUAL

Model 1916

28" GRIDDLE

AIRFRYER COMBO



CONFORMS TO ANSI STD. Z 21.89-2017
CERTIFIED TO CSA STD. 1.18-2017
OUTDOOR COOKING SPECIALTY GAS APPLIANCES.

Intertek
5015923

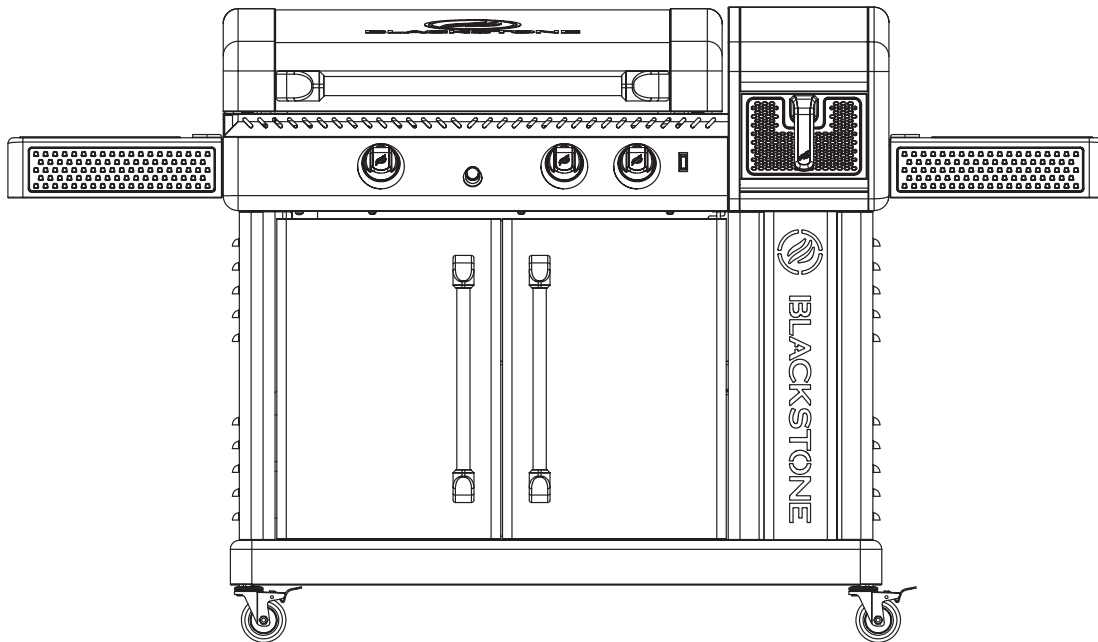

ENGLISH

Please reference blackstoneproducts.com/support for the latest version of this manual, and to follow along with assembly videos.



⚠ DANGER

Never operate this appliance unattended.

⚠ WARNING

INSTALLER/ASSEMBLER:

Leave these instructions with consumer.

CONSUMER:

Retain this manual for future reference.

⚠ WARNING

This instruction manual contains important information necessary for the proper assembly and safe use of the appliance.

Read all warnings and instructions before assembling the appliance.

⚠ WARNING

Follow all warnings and instructions while using the appliance.

⚠ WARNING

This product can expose you to chemicals including Di(2-Ethylhexyl) Phthalate (DEHP), which is known to the State of California to cause cancer and birth defects or other reproductive harm, and Diisononyl Phthalate(DINP), which is known to the State of California to cause cancer. For more information, go to www.P65Warnings.ca.gov.

⚠ DANGER

Do not store or use gasoline or other flammable liquids or vapors in the vicinity of this or any other appliance.

An LPG cylinder not connected for use shall not be stored in the vicinity of this or any other appliance.

⚠ DANGER

When cooking with oil or grease, have a type BC or ABC fire extinguisher readily available.

⚠ DANGER

If a fire should occur, keep away from the appliance and immediately call your fire department. **DO NOT** attempt to extinguish an oil or a grease fire with water.

⚠ DANGER

IF YOU SMELL GAS:

1. Shut off gas to appliance.
2. Extinguish any open flame.
3. Open lid.
4. **If odor continues, keep away from appliance and immediately call your gas supplier or your fire department.**

Failure to follow these instructions could result in fire or explosion which could cause property damage, personal injury or death.

⚠ DANGER

- This appliance is for outdoor use only, and is not to be used in a building, garage, or any other enclosed area.
- This device is not to be used in or on recreational vehicles or boats.
- This appliance is not be used on or under any apartment or condominium balcony or deck.

⚠ DANGER

- **NEVER** operate this appliance within 10 ft (3 m) of any structure, combustible material or other gas cylinder.
 - **NEVER** operate this appliance within 25 ft (7.5 m) of any flammable liquid.
- Failure to follow these instructions may result in fire, explosion or burn hazard which could cause property damage, personal injury or death.



⚠ DANGER

- The power cord must be electrically grounded in accordance with local codes or, in the absence of local codes, with the National Electrical Code, ANSI/NFPA 70, or the Canadian Electrical Code, CSA C22.1.
- Keep the electrical supply cord and the fuel supply hose away from any heated surface(s).
- Use only a Ground Fault Interrupter (GFI) protected circuit.
- Never remove the grounding plug or use with an adapter of 2 prongs.
- Use only extension cords with a 3 prong grounding plug, rated for the power of the equipment, and approved for outdoor use with a W-A marking.

⚠ IMPORTANT SAFEGUARDS

When using electrical appliances, basic safety precautions should always be followed including the following:

1. Read all instructions.
2. Do not touch hot surfaces. Use handles or knobs.
3. To protect against electrical shock do not immerse cord, plugs, or appliance in water or other liquid.
4. Close supervision is necessary when any appliance is used by or near children.
5. Unplug from outlet when not in use and before cleaning. Allow to cool before putting on or taking off parts.
6. Do not operate any appliance with a damaged cord or plug or after the appliance malfunctions or has been damaged in any manner. Return appliance to the nearest authorized service facility for examination, repair, or adjustment.
7. The use of accessory attachments not recommended by the appliance manufacturer may cause injuries.
8. For Household use only.
9. Do not let cord hang over edge of table or counter, or touch hot surfaces.
10. Do not place on or near a hot gas or electric burner, or in a heated oven.
11. Extreme caution must be used when moving an appliance containing hot oil or other hot liquids.
12. To disconnect, turn any control to "off", then remove plug from wall outlet.
13. Do not use appliance for other than intended use.
14. Fuel, such as charcoal briquettes, is not to be used with appliance.
15. Use only on properly grounded outlet.
16. CAUTION: Risk of Electric Shock. Keep extension cord connection dry and off the ground.
17. For Outdoor use only, do not expose to rain.
18. Be sure that handles are assembled and fastened properly.

SAVE THESE INSTRUCTIONS

For extension cords:

- a. A short power-supply cord is provided to reduce the risk resulting from becoming entangled in or tripping over a longer cord.
- b. Longer power-supply cords or extension cords are available and may be used if care is exercised in their use.
- c. If a longer power-supply cord or extension cord is used:
 1. The marked electrical rating of the cord set or extension cord should be at least as great as the electrical rating of the appliance;
 2. The cord should be arranged so that it will not drape over the countertop or tabletop where it can be pulled on by children or tripped over unintentionally; and
 3. The cord set or extension cord should be a grounding-type 3-wire cord.
- d. Outdoor extension cords should be used with outdoor use products and are surface marked with the suffix letter "W" and with a tag stating "Suitable for use with outdoor appliances."
- e. The connection to an Extension cord should be kept dry and off the ground.
- f. Store products indoors when not in use - out of the reach of children.
- g. Do not clean this product with a water spray or the like.



TABLE OF CONTENTS

It is the consumer's responsibility to see that the unit is properly assembled, installed, and maintained. Failure to follow the instructions in this manual could result in bodily injury and/or property damage.

CONTENTS

- 01. REGISTER YOUR PRODUCT 01**
- 02. FOR YOUR SAFETY 02**
 - Section 01. Food Safety 02
 - Section 02. Gas Appliance Safety 03
 - Section 03. Air Fryer Safety..... 04
- 03. RECIPES..... 05**
- 04. ASSEMBLY GUIDE 06**
- 05. FUEL | 20 LB. (9 KG) PROPANE TANK..... 20**
 - Section 01. LPG Cylinder Requirements 20
 - Section 02. Connection & Removal..... 21
 - Section 03. Leak Test Instructions 23
- 06. CARE & MAINTENANCE..... 24**
 - Section 01. General Care..... 24
 - Section 02. Cleaning the Burner Assembly 26
 - Section 03. Griddle Seasoning Instructions..... 28
 - Section 04. Cleaning Your Griddle Top 30
 - Section 05. Cleaning Your Air Fryer 32
- 07. IGNITION | AIR FRYER..... 33**
- 08. IGNITION | BATTERY POWERED 34**
- 09. TROUBLESHOOTING 35**
 - Section 01. Battery Powered Ignition 35
 - Section 02. Gas Flow..... 36
- 10. RECIPES..... 38**
- 11. WARRANTY..... 39**

SAFETY ALERT KEY

Read and follow all the notices throughout the manual.

DANGER
Indicates an imminently hazardous situation which, if not avoided, may result in death or serious injury.
WARNING
Indicates the possibility of serious bodily injury if the instructions are not followed.
CAUTION
Indicates a potentially hazardous situation which, if not avoided, may result in minor or moderate injury.



REGISTER YOUR PRODUCT

Registration allows our Customer Service Representatives to quickly provide assistance with your Blackstone product if needed.

The North Atlantic Imports LLC 3-Year Warranty covers replacement parts up to three years after the date of purchase. (Please reference the Warranty chapter for more information.) To enable this warranty, you will need to provide:

- Proof of Purchase/ Receipt/ Order Details
- Your Blackstone product's Serial Number
- Your Blackstone product's Model Number

Your Blackstone product's Serial and Model numbers can be found on your griddle's Origin Label. (The Origin Label is a large silver sticker found on the body of your appliance.)

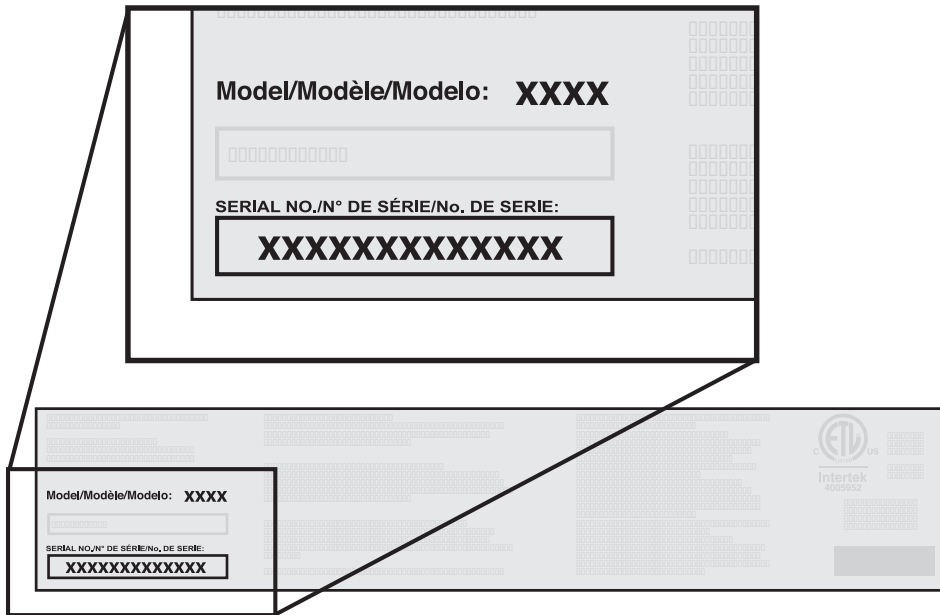

OUR CUSTOMER SERVICE STAFF IS HERE TO HELP YOU!

Register your Blackstone product at **blackstoneproducts.com/register** and visit us online at **blackstoneproducts.com/support**



Model Number _____

Serial Number _____

Date Purchased _____

We are pleased to help you with any questions concerning appliance use, replacement parts, or your warranty.

Customer Service Hours:

Monday - Friday
7:00 am - 5:00 pm (MST)



⚠ WARNING

NEVER partially cook meat or poultry to finish cooking later. Cook food completely to destroy harmful bacteria.

⚠ WARNING

The use of alcohol, prescription or non-prescription drugs may impair the consumer's ability to properly assemble or safely operate the appliance.

⚠ WARNING

Keep children and pets away from appliance at all times.
 This appliance is not intended for use by children.
 Close supervision is necessary when any appliance is used by or near children.

⚠ WARNING

This appliance is not intended for and should never be used as a heater.
Do not use for purposes other than intended.

⚠ CAUTION

Do not move the appliance when in use. Allow cooking vessel to cool to 115° F (45° C) before moving or storing.

⚠ CAUTION

For residential and household use only. **DO NOT** use for commercial cooking.

FOR YOUR SAFETY

Before proceeding, make certain that you understand the FOR YOUR SAFETY section of this manual. Hazardous fire or explosion may result if instructions are ignored.

Section 01 FOOD SAFETY

Food safety is an important part of enjoying the outdoor cooking experience. To keep food safe from harmful bacteria, follow these four basic steps:

CLEAN: Wash hands, utensils, and surfaces with hot soapy water before and after handling raw meat and poultry.

SEPARATE: Separate raw meats and poultry from ready-to eat foods to avoid cross contamination. Use clean platter and utensils when removing cooked foods from appliance.

COOK: Cook meat and poultry thoroughly to kill bacteria. Use thermometer to ensure proper internal food temperatures.

CHILL: Refrigerate prepared foods and leftovers promptly.

For more information visit foodsafety.gov or Canadian Partnership for Consumer Food Safety Education online at befoodsafe.ca

HOW TO TELL IF MEAT IS COOKED THOROUGHLY

Meat and poultry cooked with this appliance often browns very fast on the outside.

Use a meat thermometer to be sure food has reached a safe internal temperature and cut into food to check for visual signs of doneness.

When reheating takeout foods or fully cooked meats like hot dogs, cook to 165° F (74° C), or until steaming hot.

MEAT COOKING TEMPERATURES



Poultry
 165° F or 74° C
 Juices should run clear and flesh should not be pink.

Beef or Poultry Hamburger
 160° F or 71° C
 Juices should not be pink and flesh should be brown in the middle.

Beef, Veal, & Lamb Steaks/Chops
 145° F or 63° C

Beef, Veal, & Lamb Roasts
 145° F or 63° C

ALL cuts of Pork
 160° F or 71° C
 Juices should not be pink.



Section 02

GAS APPLIANCE SAFETY

INSTALLATION SAFETY

This appliance is safety certified for use in the United States and/ or Canada only. Do not modify for use in any other location.

Modification will result in a safety hazard and void warranty.

Appliance installation must conform with local codes, or in the absence of local codes, with either the National Fuel Gas Code, ANSI Z223.1/ NFPA 54, Natural Gas and Propane Installation Code, CSA B149.1, or Propane Storage and Handling Code, B149.2, or the Standard for Recreational Vehicles, NFPA 1192, and CSA Z240 RV Series, Recreational Vehicle Code, as applicable.

If grease or other hot material drips from appliance onto valve, hose or regulator:

STEP 01 Turn off gas supply immediately.

STEP 02 Determine the cause and correct it.

STEP 03 Clean and inspect valve, hose and regulator before continuing.

STEP 04 Perform a leak test. (Please reference the Leak Test Instructions in the Fuel chapter.)

For problems with this appliance, please reference the Troubleshooting chapter.

⚠ DANGER

When not in use, turn OFF appliance by rotating the appliance control knobs to the OFF position and closing the fuel valve.

If the information in the above statements is not followed exactly, serious injuries, fire, or death may occur.

⚠ WARNING

Use this appliance, as purchased, only with gas and regulator/valve assembly supplied.

⚠ CAUTION

Use long-handled cooking utensils and oven mitts to protect against burns and splatters.

⚠ CAUTION

- Do not place any empty cooking vessels on the cooking surface while in operation.
- Use caution when placing anything in cooking vessel while the appliance is in operation.

⚠ DANGER

Never place any items within 3-inches of the cooking surface while in use. This area can become very hot and potentially damage any accessory objects placed too close.

⚠ DANGER

DO NOT operate this appliance any closer than 36 in (1 m) from the sides and back of the appliance. Do not use this appliance under overhead combustible surfaces.

A = 36" (1 m)

⚠ WARNING

Fuels used in liquefied propane gas appliances, and the products of combustion of such fuels, can expose you to chemicals including benzene, which is known to the State of California to cause cancer and cause birth defects or other reproductive harm. For more information go to www.P65Warnings.ca.gov.

ENGLISH



⚠ DANGER

This appliance is not for frying turkeys.

⚠ DANGER

- Operating the air fryer can cause the griddle to become hot. Do not touch hot surfaces. Use protective gloves or mitts when opening drawers to prevent burns, as the drawer face may be hot.
- Do not place fryer drawers on griddle surface.
- Do not place fryer drawers on or near a hot gas or electric burner, or in a heated oven.

⚠ WARNING

DO NOT clean with alcohol or any other flammable substance.

ENGLISH

Section 03

AIR FRYER SAFETY

AIR FRYER

- Do not restrict the flow of the combustion air or the hot exhaust gasses.
- Blow out drawers before cooking to keep passageways clean.
- Remove items from bottom shelf of the unit before operating the air fryer.
- Allow to cool before putting on or taking off parts, cleaning or moving.

EXTENSION CORDS

Longer power-supply cords or extension cords are available and may be used if care is exercised in their use.

FOOD

- Do not cook food in the drawer without the basket in place.
- Do not overfill basket, air needs to flow around and between the pieces of food.
- Use a food thermometer to confirm food is cooked.
- If food begins to burn, turn off burners and close tank valve.
- Food in the baskets will become very hot, use gloves and/or tongs to handle food.
- Do not add liquids (water or sauces) to hot food in the drawer as it may flash to steam and cause burns.
- Use caution when removing drawers as hot food or hot liquids may spill.



RECIPES FOR THE AIR FRYER

JALAPEÑO CORNBREAD POPPERS

STEP 01 Cook bacon on griddle until done. Once cooled, chop finely and set aside.

STEP 02 Wash jalapeños and pat dry. Cut in half lengthwise. With a small spoon, scrape the white membranes and seeds away from the jalapeño. Dry jalapeños with a paper towel and set aside.

NOTE: Consider wearing protective rubber gloves when preparing jalapeños.

STEP 03 Make Jiffy corn muffin mix based on manufacturer's directions.

STEP 04 Stir the finely chopped bacon and cheddar cheese into the corn muffin mix.

STEP 05 Preheat air fryer to medium.

STEP 06 Spoon roughly a teaspoon of corn muffin and bacon mix into each jalapeno half. Spread the batter evenly from top to bottom.

NOTE: Resist the temptation to fill the jalapeños with mix, as it can double in size.

STEP 07 Cook the stuffed jalapeños for 8-10 minutes until the cornbread is golden browned and cooked throughout.

STEP 08 Allow to cool.

STEP 09 Using a heat safe ramekin or small baking dish, combine honey and butter and place in the air fryer for 3-5 minutes. Stir frequently until completely melted. Drizzle hot honey butter over jalapeño cornbread bites and serve immediately.



🍴 Serves 4 - 6 | **🕒** 50 min.

Ingredients

- 12 fresh jalapeños
- 1 box Jiffy cornbread muffin mix
- 6 slices bacon
- 3/4 cup grated cheddar cheese
- 3 tablespoons honey
- 2 tablespoons butter

VIDEO RECIPES:

Find more inspiration and recipes at



[blackstoneproducts.com/
blogs/recipes](https://blackstoneproducts.com/blogs/recipes)



[youtube.com/c/
BlackstoneGriddles](https://youtube.com/c/BlackstoneGriddles)



@blackstoneproducts



ASSEMBLY GUIDE

EXPLODED VIEW

ENGLISH

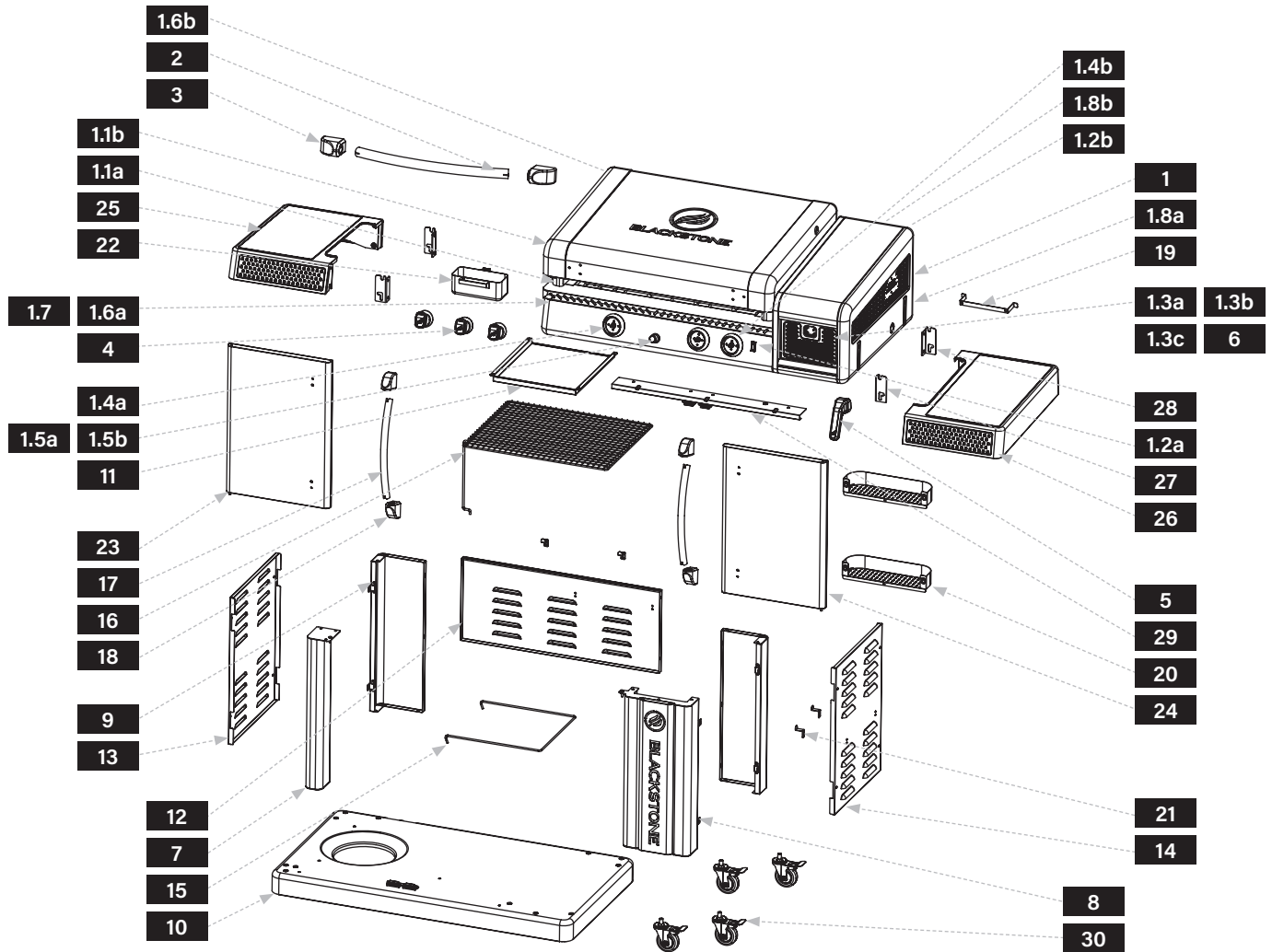











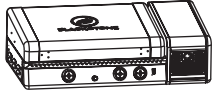
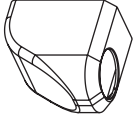

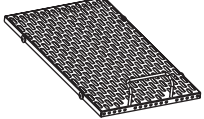
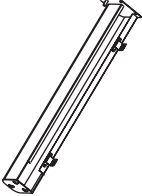
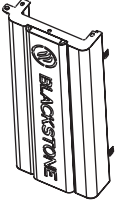
PARTS	QTY
1.1a Griddle top	1
1.1b Hood	1
1.2a Motor switch	1
1.2b Power cord	1
1.3a Air fryer drawer body	1
1.3b Air fryer drawer front panel	1

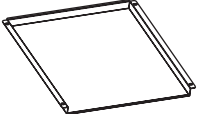
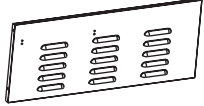
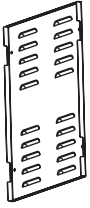
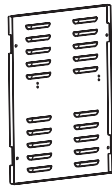
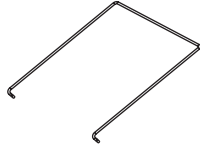
PARTS	QTY
1.3c Silicone pad (4 pieces per pack)	1
1.4a Griddle control knob bezels	2
1.4b Air fryer control knob bezel	1
1.5a Electric ignitor	1

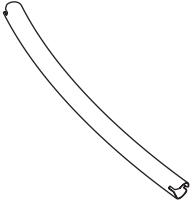
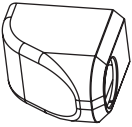
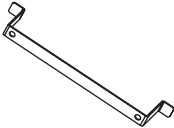
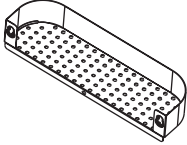
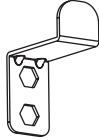
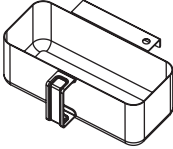
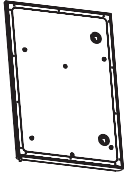
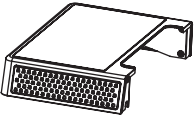
PARTS	QTY
1.5b Electric ignitor wire (3 pieces per set) with electrode	1
1.6a Gas rail & valves	1
1.6b H burners	2
1.7 Regulator hose	1
1.8a Air fryer burner	1
1.8b Motor assembly	1

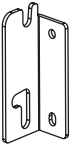

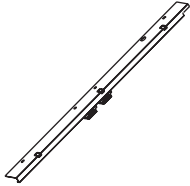
ILLUSTRATED PARTS LIST

<p>1 Griddle body (1 piece)</p> 	<p>2 Hood handle (1 piece)</p> 	<p>3 Hood handle standoffs (2 pieces)</p> 	<p>4 Control knobs (3 pieces)</p> 	<p>5 Air fryer drawer handle (1 piece)</p> 	<p>6 Air fryer drawer trivet (1 piece)</p> 
<p>7 Left front leg (1 piece)</p> 	<p>8 Right front leg (1 piece)</p> 	<p>9 Back legs (2 pieces)</p> 	<p>10 Cart base (1 piece)</p> 	<p>11 Gas tank heat shield (1 piece)</p> 	<p>12 Back panel (1 piece)</p> 
<p>13 Left panel (1 piece)</p> 	<p>14 Right panel (1 piece)</p> 	<p>15 Gas tank holding wire (1 piece)</p> 	<p>16 Inner shelf (1 piece)</p> 	<p>17 Door handles (2 pieces)</p> 	<p>18 Door handle standoffs (4 pieces)</p> 
<p>19 Power cord bracket (1 piece)</p> 	<p>20 Condiment racks (2 pieces)</p> 	<p>21 Shelf brackets (4 pieces)</p> 	<p>22 Grease cup (1 piece)</p> 	<p>23 Left cart door (1 piece)</p> 	<p>24 Right cart door (1 piece)</p> 
<p>25 Left shelf (1 piece)</p> 	<p>26 Right shelf (1 piece)</p> 	<p>27 Left shelf brackets (a.) (2 pieces)</p> 	<p>28 Right shelf brackets (b.) (2 pieces)</p> 	<p>29 Magnetic bracket (1 piece)</p> 	<p>30 Lockable caster wheels (4 pieces)</p> 



31 Hardware pack (1 piece)

- a. M6x15 screws (40 pieces)
- b. M5x10 screws (18 pieces)
- c. M4x10 screws (8 pieces)
- d. Ni plated M4x10 screws (2 pieces)
- e. M6 step bolts (8 pieces)
- f. M5x15 screws (4 pieces)
- g. Ni plated M6 step bolts (6 pieces)
- h. Cotter pins (2 pieces)
- i. Spares

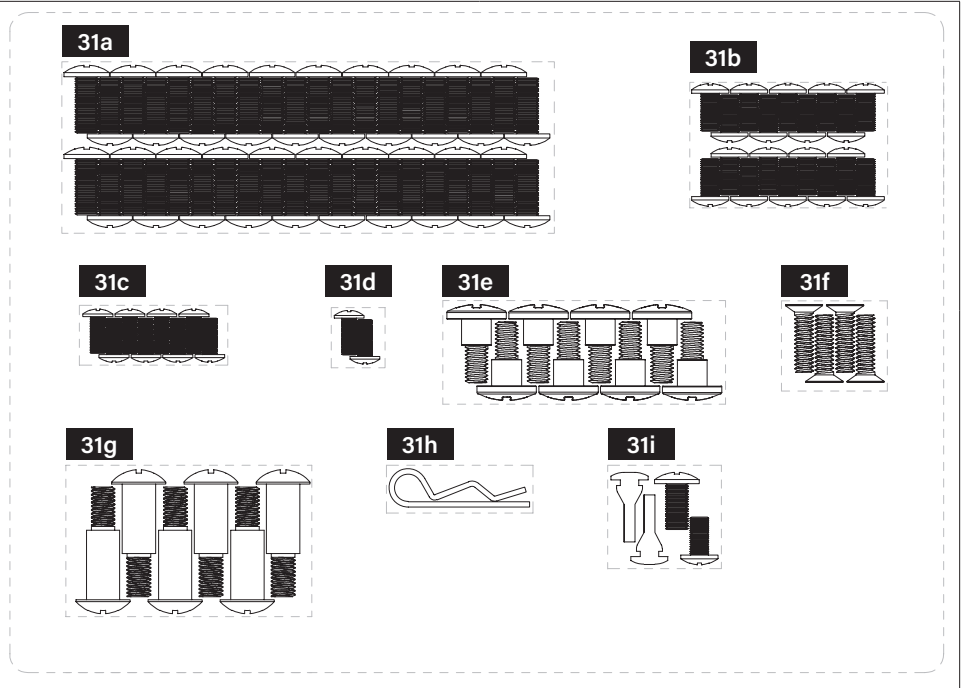

ELECTRIC REQUIREMENTS: 120V 60Hz 1.0A

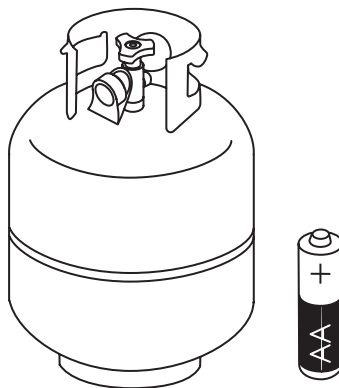
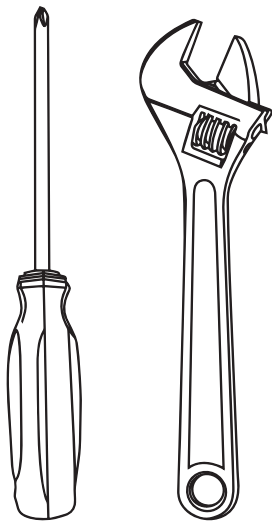

TOOLS NEEDED: Phillips head screwdriver & Adjustable wrench

NOT INCLUDED: 20 lb (9 kg) LPG tank & AA Battery



ASSEMBLY INSTRUCTIONS

Please read all instructions thoroughly before proceeding. Make sure all the plastic packing material is removed before assembling.

Find a large, clean area to assemble your unit. Please refer to the parts list and assembly diagrams as necessary.

STEP 01 Turn the cart base upside down. Use a wrench to attach the four (4) caster wheels to the cart base.

(Ensure that the caster wheels are locked before attaching them.)

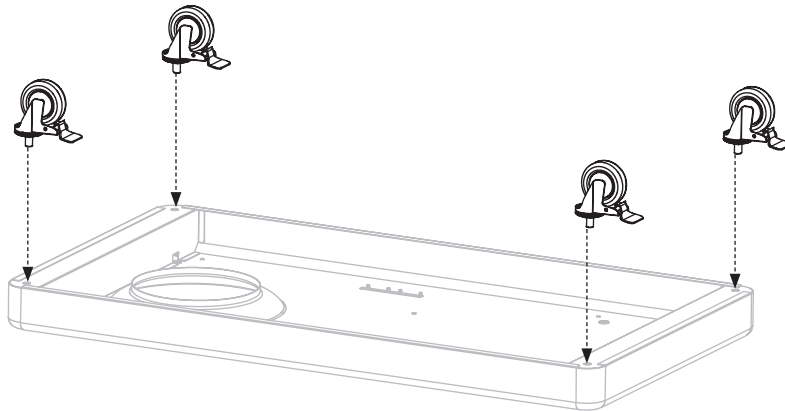
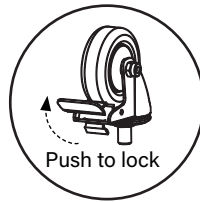

STEP 02 Insert the gas tank holding wire into the cart base and use two (2) cotter pins to secure it from underneath.

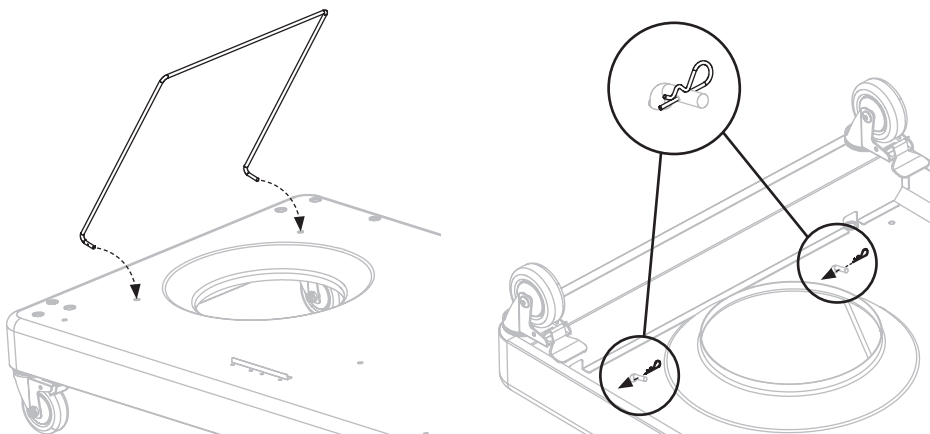

⚠ WARNING

The manufacturer has made every effort to eliminate any sharp edges. However, you should handle all components with care to avoid accidental injury.

Some parts may contain sharp edges, especially as noted in these instructions. Wear protective gloves if necessary.

⚠ CAUTION

Two people are recommended for the assembly of this product.



STEP 03 Use three (3) M6x15 screws to attach the right-front leg to the cart base.

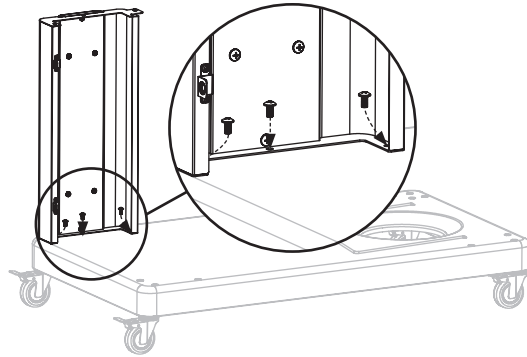

STEP 04 Use three (3) M6x15 screws to attach the left-front leg to the cart base.

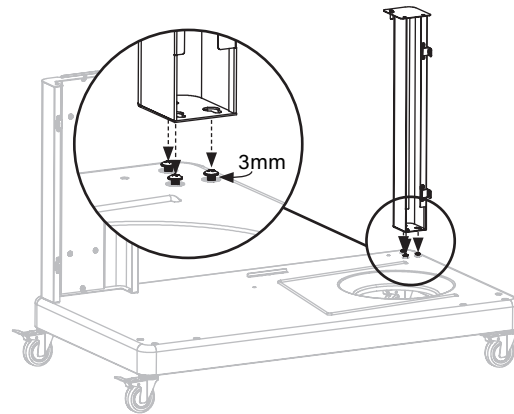

STEP 05 Use three (3) M6x15 screws to attach the back leg to the cart base.

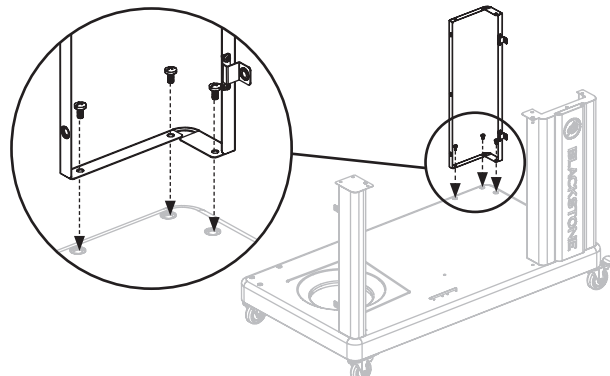



STEP 06 Use three (3) M6x15 screws to attach the back leg to the cart base.

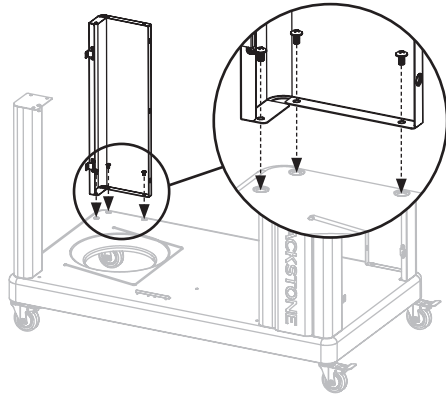

STEP 07 Use four (4) M4x10 screws to attach two (2) shelf brackets to the back panel.

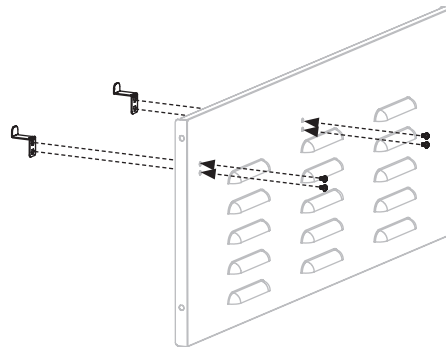

STEP 08 Use four (4) M5x10 screws to attach the back panel to the rear legs.

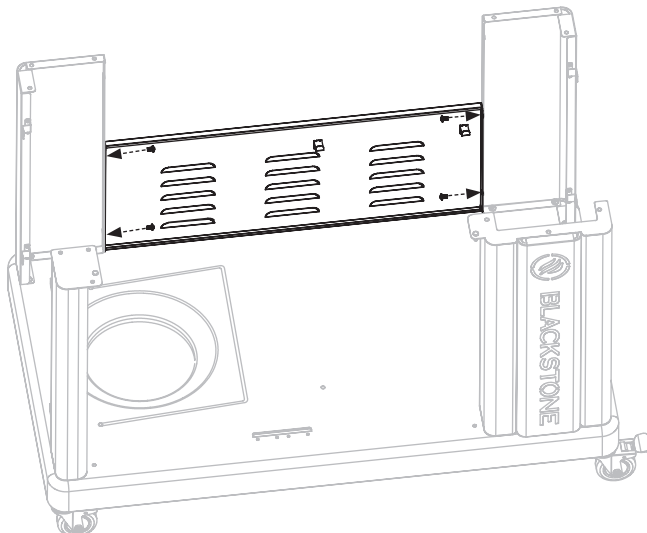



STEP 09 With the help of another person, place the griddle body on the cart and secure with twelve (12) M6x15 screws from underneath the leg plates.

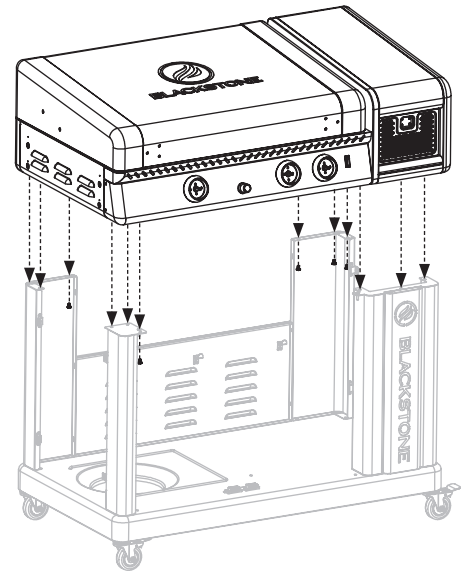

STEP 10 Use four (4) M5x10 screws to attach the gas tank heat shield to the bottom panel of the griddle body.

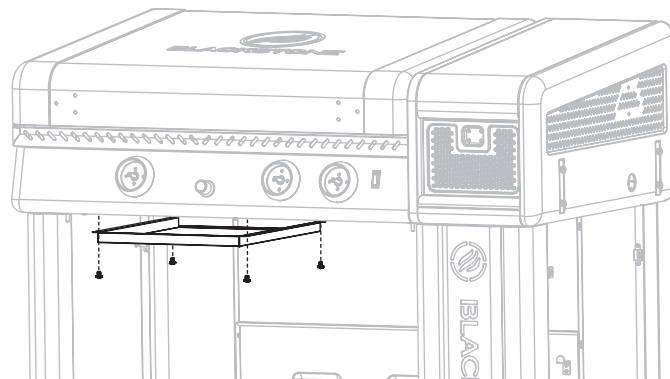

STEP 11 Use four (4) M6x15 screws to attach the magnet bracket to the lower-front side of the griddle body.

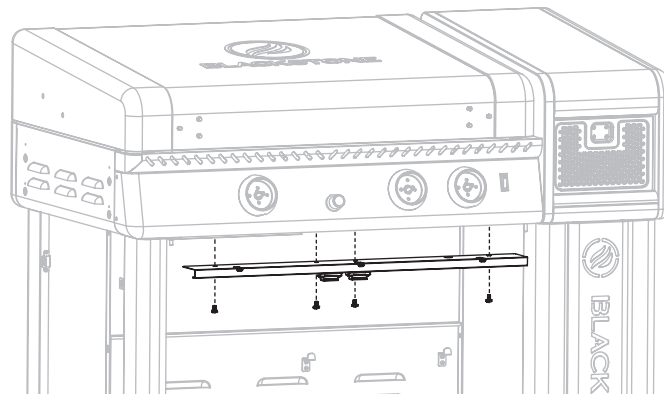



STEP 12 Use four (4) M5x10 screws to attach the left panel to the left legs.

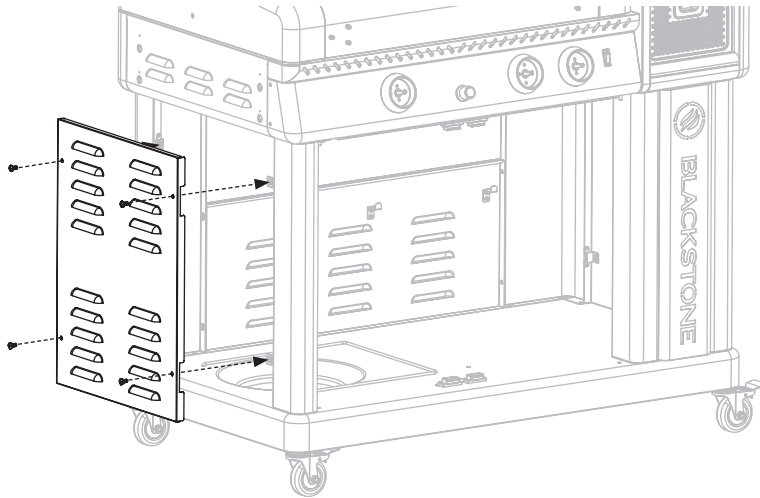

STEP 13 Use four (4) M4x10 screws to attach two (2) shelf brackets to the right panel.

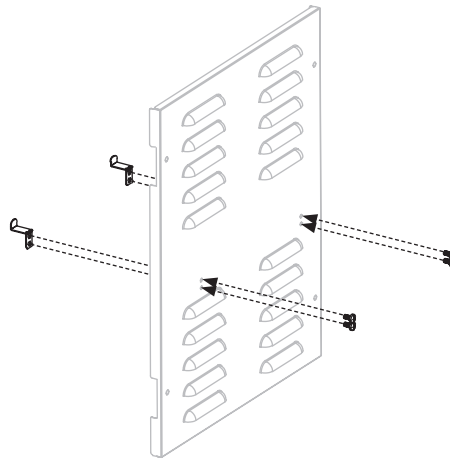

STEP 14 Use four (4) M5x10 screws to attach the right panel to the right legs.

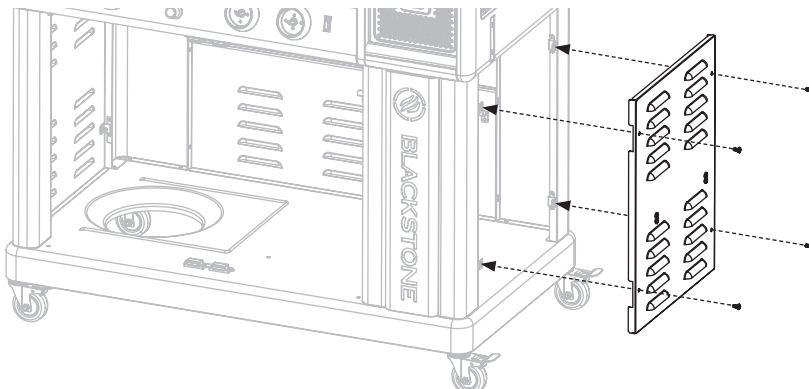



STEP 15 Install the inner shelf by resting the shelf on the four (4) inner shelf brackets, and inserting the leg into the cart base hole.

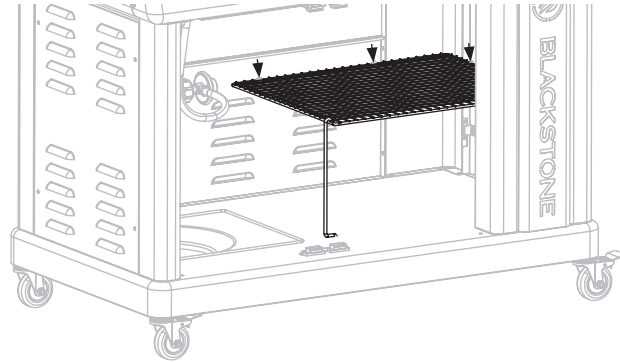

STEP 16 Use two (2) M6x15 screws to attach one (1) cart door handle to the left cart door.

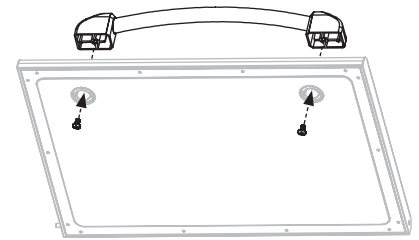

STEP 17 Attach the left cart door to the cart by first **1** inserting the upper door hinge pin, then **2** inserting the lower door hinge pin.

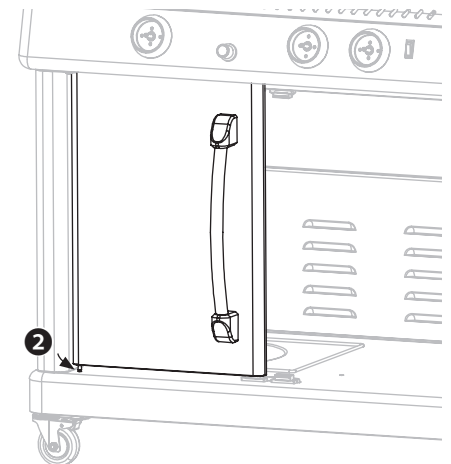
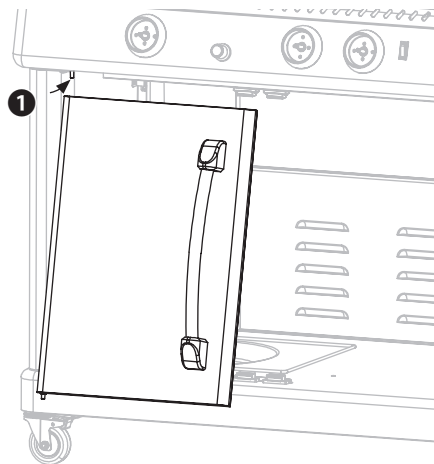

STEP 18 Use two (2) M6x15 screws to attach one (1) cart door handle to the right cart door.

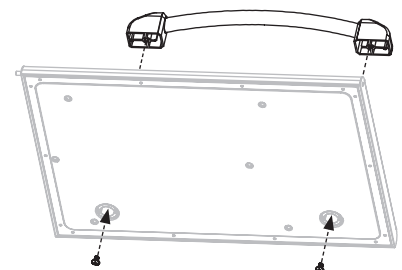



STEP 19 Hang the two (2) condiment racks on the preinstalled screws on the right cart door.

Use two (2) M4x10 screws to secure the racks.

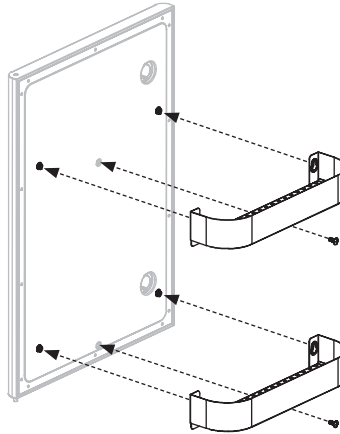

STEP 20 Attach the right cart door to the cart by first **1** inserting the upper door hinge pin, then **2** inserting the lower door hinge pin.

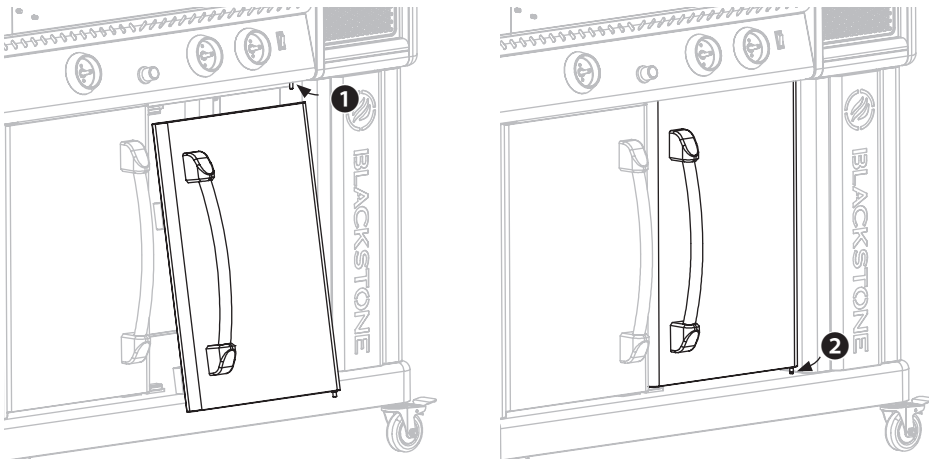

STEP 21 Use eight (8) M6x15 screws to attach the four (4) side shelf brackets to the sides of the body. Use one left shelf bracket (**a.**) and one right shelf bracket (**b.**) per side.

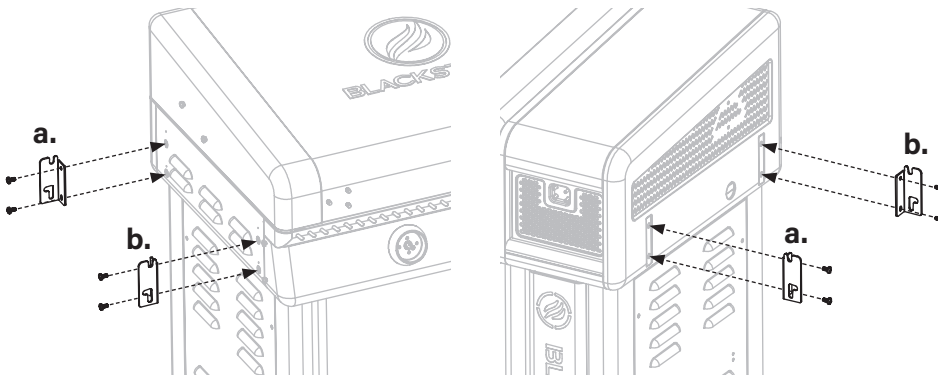

ENGLISH



CAUTION

- Maximum weight on the side shelf is 10 lbs (4.5 kg).
- The side shelf may get hot while griddle is in use.

ENGLISH

STEP 22 Thread two (2) M6 step bolts into the top holes on the left side shelf and two (2) M6 step bolts into the top holes on the right shelf.

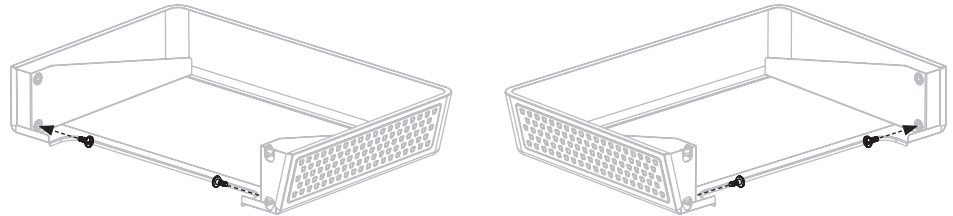

STEP 23 Slide the right shelf onto the shelf brackets. (The threaded M6 step bolts will hook and hold the shelf.) Thread two (2) M6 step bolts into the bottom hole of the bracket to secure the shelf to the griddle body.

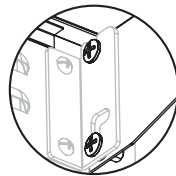
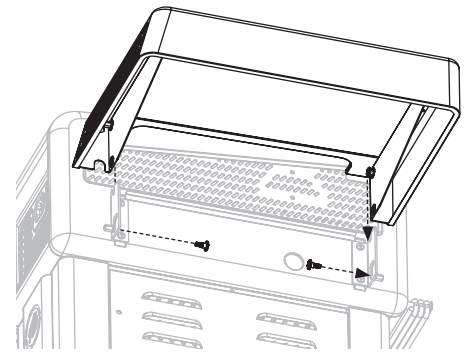

Repeat this step with the left side shelf.

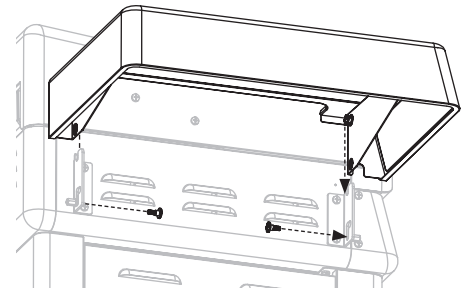

STEP 24 Use two (2) M5x10 screws to attach the power cord bracket to the back of the air fryer.

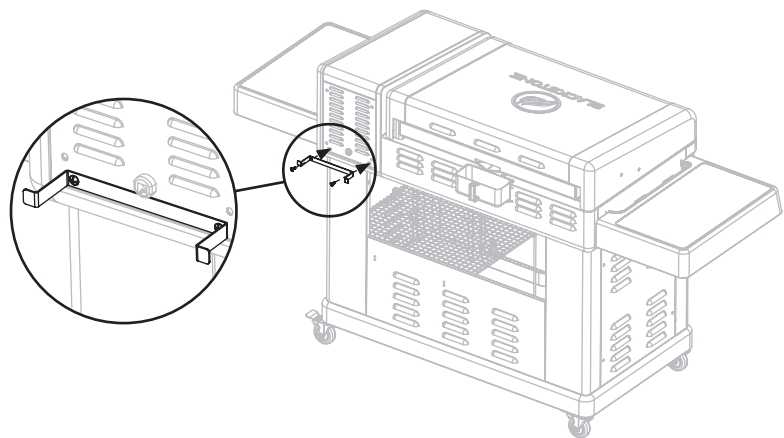



STEP 25 Hang the grease cup in the slot on the back of the griddle body.

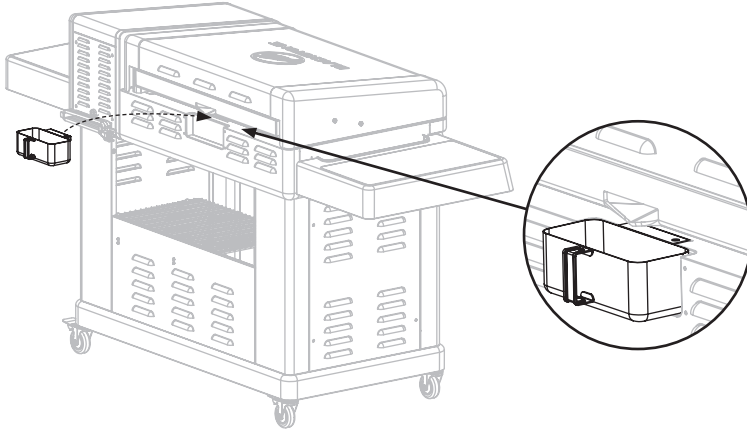

WARNING
Do not leave the hood closed for more than 10 minutes while cooking.

STEP 26 Install the three (3) control knobs by pushing them into place in the OFF position.

Insert one (1) AA battery (not included) under the ignition button.

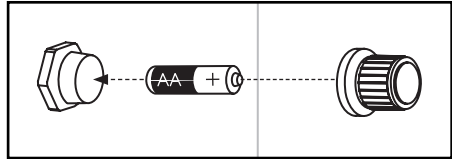

Insert one (1) AA battery (not included) into the battery socket with the positive terminal facing out, then screw on the ignitor button until tight. Be careful to not over tighten.

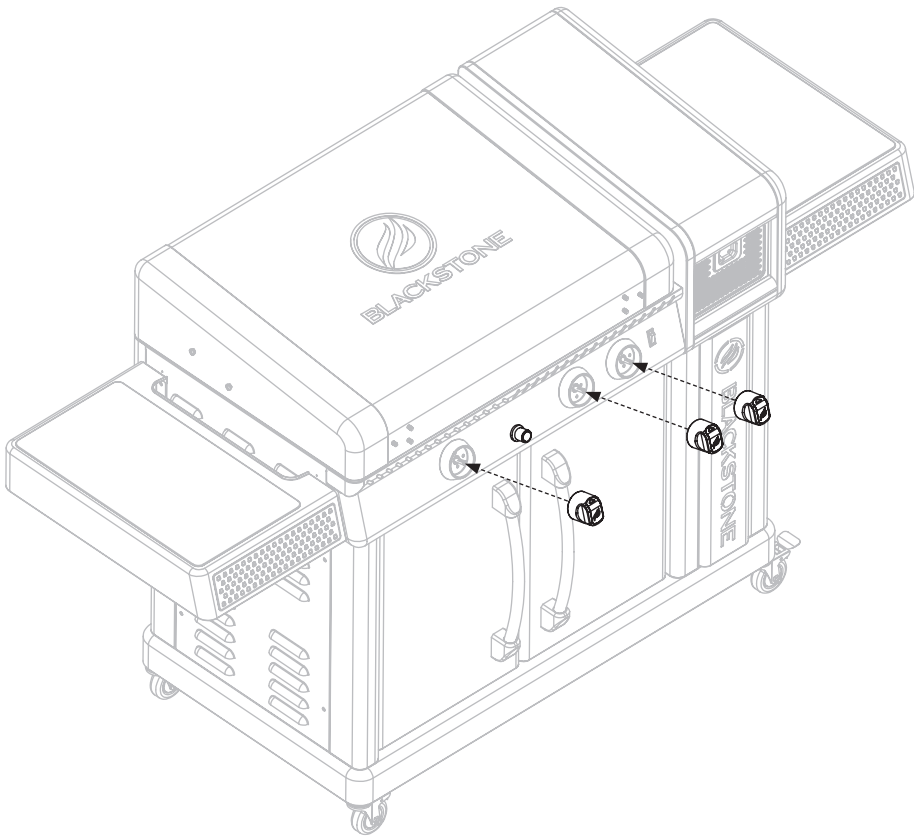

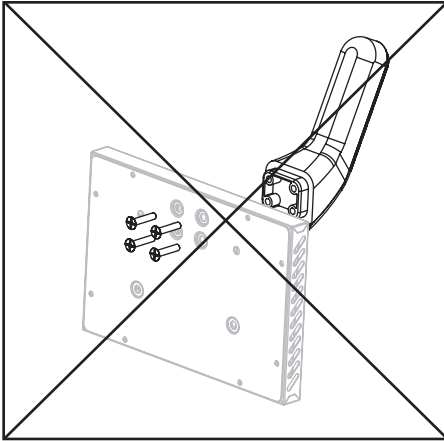

Be sure to install handle correctly, with the handle facing down.

STEP 27 Attach the air fryer drawer handles by first removing the two small thumb screws from inside the drawer and taking off the air fryer drawer front panel.

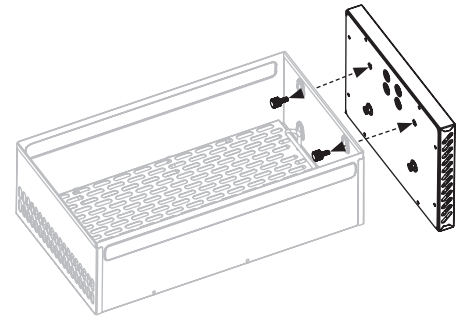

Next, use four (4) M5x15 screws to attach the drawer handle to the air fryer drawer front panel.

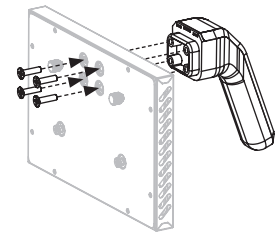

Use the previously removed thumb screws to re-attach the air fryer drawer front panel.

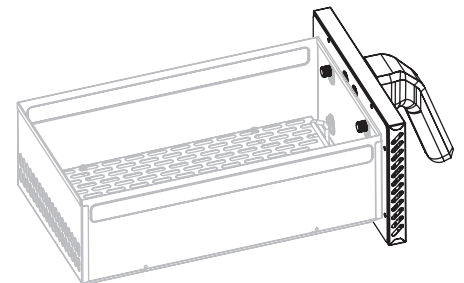

STEP 28 Use six (6) M6 step bolts to attach the lid handle and two (2) hood handle standoffs to the griddle hood.

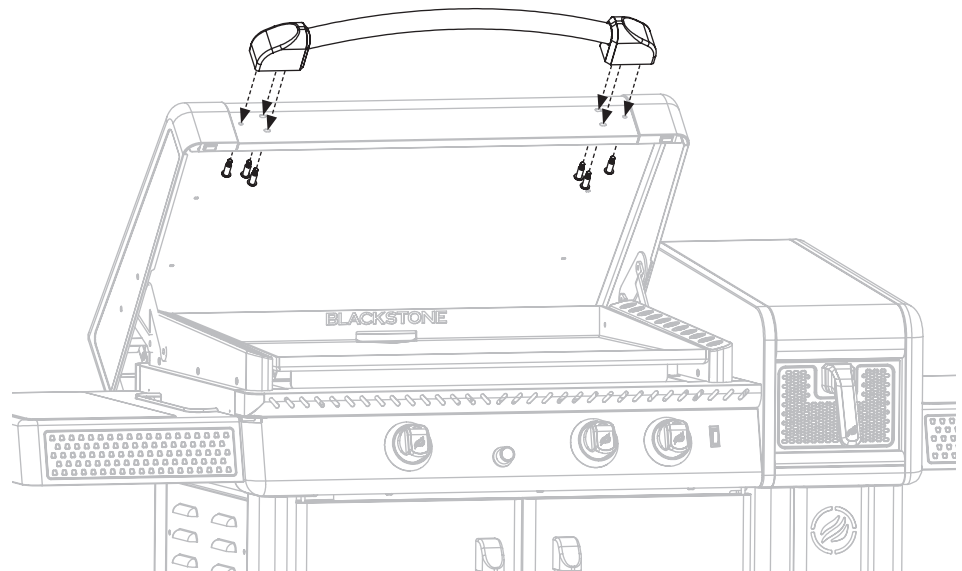



STEP 29 With the help of another person, lift the griddle top with hood assembly, take out the protective washers from griddle legs and place the griddle top on the main body by aligning the four (4) pins to the holes of the body. Ensure that the front pins are fully seated in the holes, then push the griddle top back to lock the griddle in place.

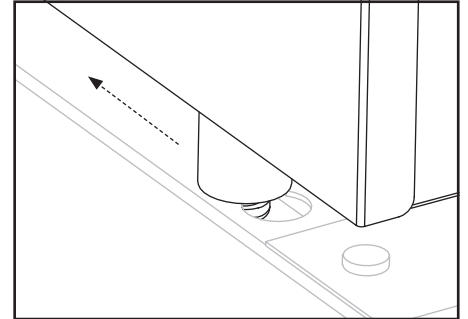

Ensure that all four pins are seated in the holes, then push the griddle top back to lock the griddle in place.

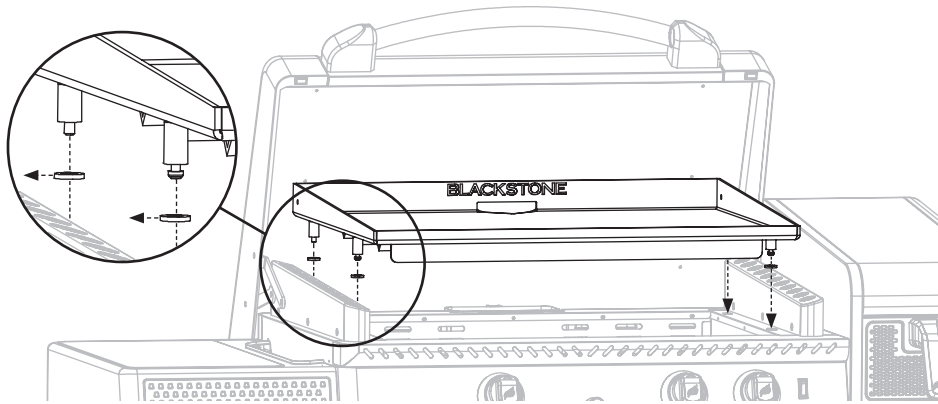

STEP 30 Connect the propane tank (not included) and set it on the cart base. (Please reference the Connection & Removal section of the Fuel chapter.) Secure the tank with the gas tank holding wire.

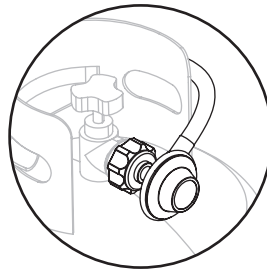

STEP 31 Proceed to the Griddle Seasoning Instructions section of the Care & Maintenance chapter.

Enjoy cooking outdoors on your Blackstone!

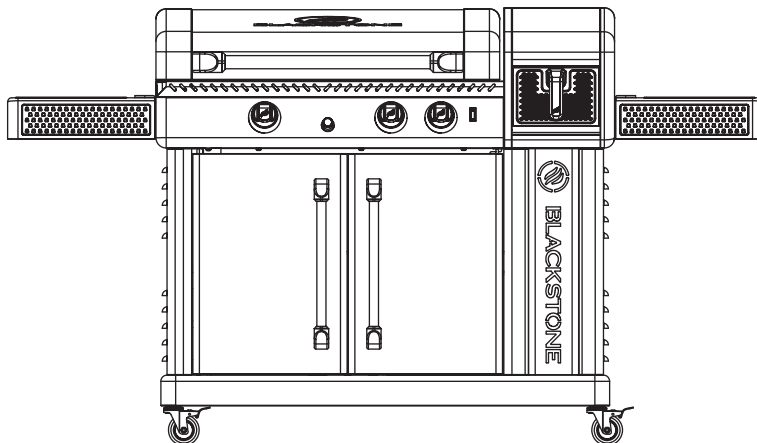

NEED HELP?

Register your Blackstone product at blackstoneproducts.com/register and visit us online at blackstoneproducts.com/support for replacement parts, assembly and operation questions.



ENGLISH

**⚠ DANGER**

- **NEVER** store a spare LPG cylinder under or near the appliance or in an enclosed area.
- **NEVER** fill an LPG cylinder beyond 80% full.
- **DO NOT** store an LPG cylinder in an area where children play.
- **LPG cylinder should only be stored outside and in a cool, dry place.**
- **NEVER** leave an LPG cylinder inside a vehicle which may become overheated by the sun.

If the information above is not followed exactly, a fire causing death or serious injury may occur.

⚠ DANGER

An overfilled or improperly stored cylinder is a hazard due to possible gas release from the safety relief valve. This could cause intense fire with risk of property damage, serious injury or death.

If you see, smell or hear gas escaping, immediately get away from the LPG cylinder and appliance and call fire department.

FUEL | 20 LB. (9 KG) PROPANE TANK

Section 01

LPG CYLINDER REQUIREMENTS

LPG CYLINDER REQUIREMENTS

The LPG Tank used with your griddle must meet the following requirements:

- Date tested by a LPG supplier within five years of use.
- Size: 18 x 12 in (45 x 30 cm), 20 lb (9 kg).
- Supply system must be arranged for vapor withdrawal.
- Tank must include collar to protect LPG Tank valve.

GAS INSTALLATION CODES

Appliances must be used in accordance with the installation requirements of your gas supply authority, and constructed and marked in accordance with the applicable standard:

- Specifications for LPG Cylinders of the U.S. Department of Transportation (DOT)
- National Standard of Canada, CAN/CSA-B339, Cylinders, Spheres, and Tubes
- Specifications for LPG cylinders, Transports Canada (TC), Transportation of Dangerous Goods (TDG)
- Australian Standard AS/NZS 5601

See LPG Tank collar for marking.

LPG TANK VALVE REQUIREMENTS

LPG Tank valve must have:

- Type 1 valve outlet (thread on the outside).
- Safety relief valve.
- UL listed Overfill Protection Device (OPD). **This OPD safety feature is identified by a unique triangular hand wheel.**

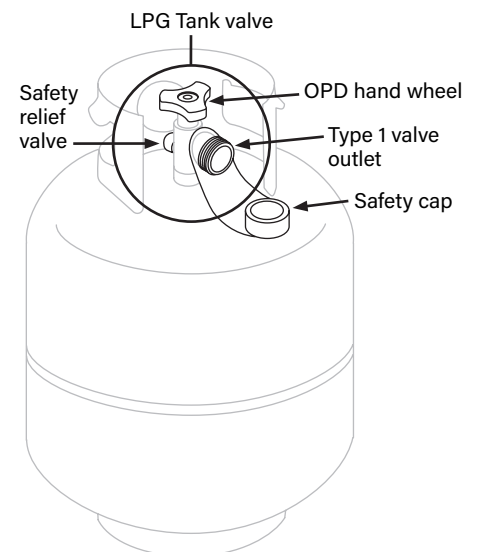

Always keep new and exchanged LPG Tanks in upright position during use, transit or storage.



Section 02

CONNECTION & REMOVAL

REGULATOR SAFETY

If regulator fails in unit, it must be replaced with a Blackstone approved model and must only be replaced by a professionally licensed, authorized dealer. Failure to comply will void the warranty.

CONNECTING THE REGULATOR TO THE LPG TANK

Leak test new and exchanged LPG tanks BEFORE connecting to griddle. Please reference the Leak Test Instructions section.

STEP 01 LPG tank must be properly secured to griddle.
(Please reference the Assembly Guide chapter.)

Ensure that the control knobs are turned to OFF.

STEP 02 ① Ensure that the LPG tank is OFF by turning the OPD hand wheel clockwise to a full stop.

② Remove the safety cap from the Type 1 valve outlet.

STEP 03 Hold the regulator in a straight line with the Type 1 valve outlet so as not to cross thread the connection.

Center and insert the regulator nipple into the Type 1 valve outlet.

Hand-tighten the coupling nut in a clockwise direction.

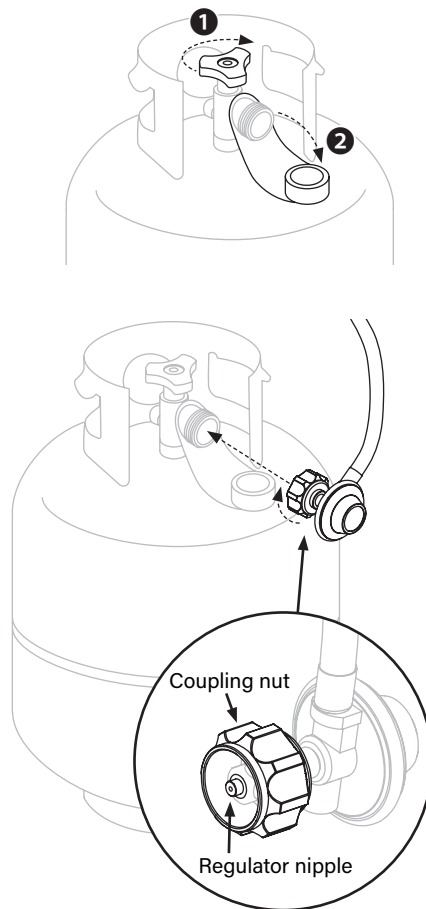

⚠ WARNING

Turn off LPG supply at cylinder when appliance is not in use.

⚠ WARNING

LPG is highly flammable and may ignite unexpectedly when mixed with air.

⚠ WARNING

Keep the fuel supply hose away from any heated surface(s).

⚠ WARNING

Never attempt to attach this griddle to the self-contained LPG system of a camper trailer, recreational vehicle or motor home.

Do not use the LPG Tank until it has been leak-tested.

⚠ CAUTION

LPG is nontoxic, odorless and colorless when produced. For safety and easy detection, LPG has been given an odor similar to rotten cabbage.

PLEASE NOTE: If connection cannot be completed, disconnect regulator and repeat step 03.

If still unable to complete connection, do not use this regulator!

**⚠ DANGER**

Do not insert any tool or foreign objects into the valve outlet or safety relief valve. The valve may be damaged resulting in a leak. **Leaking propane may result in explosion, fire, severe personal injury, or death.**

If a leak is detected at any time, STOP and call the fire department.

If unable to stop a gas leak, immediately close LPG tank valve and immediately contact an LPG gas supplier or fire department.

⚠ WARNING

Do not insert a POL transport plug (plastic part with external threads) into the Type 1 valve outlet. It will defeat the Safety relief valve feature.

**REMOVING THE LPG TANK FOR TRANSPORT/STORAGE**

STEP 01 Ensure that the control knobs are turned to OFF.

STEP 02 ① Ensure that the LPG tank is OFF by turning the OPD hand wheel clockwise to a full stop.

② Turn the coupling nut counter-clockwise by hand to remove the regulator. (Do not use tools to disconnect.)

STEP 03 Place the safety cap onto the Type 1 valve outlet.

Only use the type of safety cap on the cylinder valve outlet that is provided with the cylinder valve. (Other types of caps or plugs may result in leakage of propane.)

- A disconnected LPG tank in storage or during transportation must have a safety cap installed.
- Failure to use safety cap as directed may result in serious personal injury and/or property damage.

FITTINGS & HOSES

- Annual checking and tightening of metal fittings is recommended.
- Before each use, check to see if hoses are cut or worn.
- Replace damaged hoses before using appliance. (Use only Blackstone approved replacement parts for valve, hose, or regulator.)

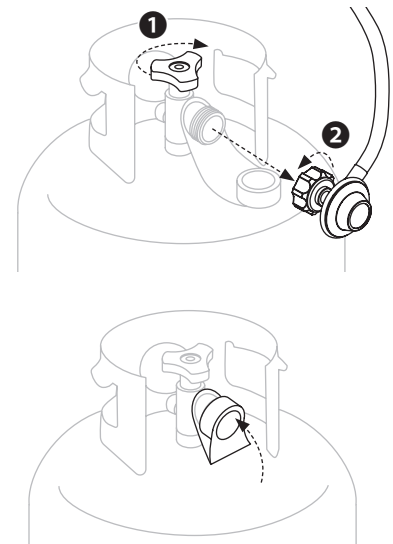
**FILLING & EXCHANGE**

Use only those reputable exchange companies that inspect, precision fill, test and certify their tanks. LPG dealer must purge new tank before filling.

Volume of propane in tank will vary by temperature. A frosty regulator indicates gas overfill. Immediately close LPG Tank valve and call local LPG gas dealer for assistance.

Do not release liquid propane (LPG) gas into the atmosphere.

To remove gas from LPG Tank, contact a certified LPG dealer or local fire department for assistance.

Exchange tank only for an OPD safety feature-equipped tank.

PLEASE NOTE: Your retailer can help you match a replacement tank to your griddle.



Section 03

LEAK TEST INSTRUCTIONS

LEAK TEST SAFETY

- Leak test must be repeated each time LPG tank is exchanged or refilled.
- Do not smoke during leak test.
- Do not use an open flame to check for gas leaks.
- Appliance must be leak tested outdoors in a well-ventilated area, away from ignition sources such as gas fired or electrical appliances.
- During leak test, keep appliance away from open flames or sparks.
- Use a clean paintbrush and a 10/90 mild soap and water solution.

LEAK TEST: LPG TANK

STEP 01 Brush soapy solution onto joint areas of tank. (Indicated by arrows in figure 01.)

Leaks are indicated by growing bubbles.

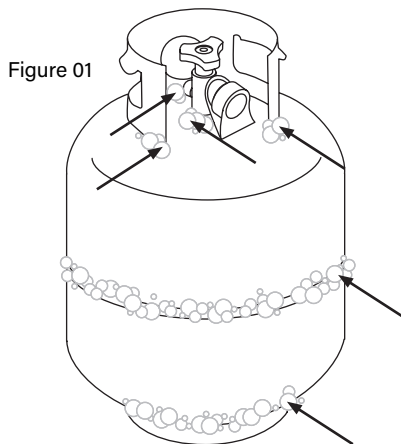

LEAK TEST: VALVES, HOSE & REGULATOR

STEP 01 Ensure that the control knobs are turned to OFF.

Ensure that the regulator is tightly connected to LPG tank.

Completely open the LPG tank by turning the OPD hand wheel counterclockwise.

If you hear a rushing sound, turn gas off immediately. There is a major leak at the connection. Correct before proceeding.

STEP 02 Brush soapy solution onto joint areas of valves and regulator. (Indicated by arrows in figure 02.)

Leaks are indicated by growing bubbles.

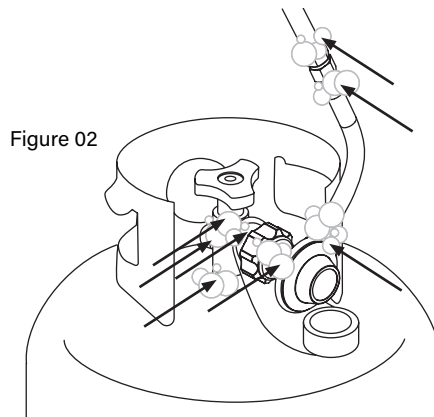

STEP 03 Immediately close the LPG tank by turning the OPD hand wheel clockwise and re-tighten connections. If leaks cannot be stopped **DO NOT TRY TO REPAIR.**

⚠ WARNING

If growing bubbles appear during leak test, do not use or move the LPG bottle. Immediately contact an LPG supplier or fire department.

⚠ CAUTION

DO NOT USE HOUSEHOLD CLEANING AGENTS. Damage to gas valve, hose, and regulator components may result.

NEED HELP?

Register your Blackstone product at blackstoneproducts.com/register and visit us online at blackstoneproducts.com/support for replacement parts, assembly and operation questions.



**⚠ WARNING**

When not in use, turn unit controls and gas source OFF.

⚠ WARNING

The appliance must be isolated from the gas supply piping system by closing its individual manual shutoff valve during any pressure testing of the gas supply piping system at test pressures equal to or less than 1/2 psi (3.5 kPa).

⚠ WARNING

This appliance will be hot during and after use. Use insulated oven mitts or gloves for protection from hot surfaces or splatter from cooking liquids.

⚠ CAUTION

NEVER handle hot parts with unprotected hands.

⚠ CAUTION

DO NOT use Citrisol, abrasive cleaners, de-greasers or a concentrated cleaner on plastic parts. **Damage to and failure of parts may result.**

CARE & MAINTENANCE

Regularly clean your appliance between uses, especially after extended periods of storage. In order to extend the life and condition of unit, follow best practices detailed in this manual.

Section 01

GENERAL CARE

GENERAL CLEANING

Ensure that the appliance and its components are sufficiently cool before cleaning.

- Clean your appliance often, preferably after each use.
- Be sure to keep the ventilation opening(s) of the cylinder enclosure free and clear from debris.
- Baked-on grease deposits may require the use of an abrasive plastic cleaning pad. Use only in direction of brushed finish to avoid damage.
- DO NOT use abrasive pad on areas with graphics.
- If a bristle brush is used to clean any of the cooking surfaces, ensure no loose bristles remain on cooking surfaces prior to cooking.

PLASTIC PARTS: Wash with warm soapy water and wipe dry.

PAINTED SURFACES: Wash with mild detergent or nonabrasive cleaner and warm soapy water. Wipe dry with soft nonabrasive cloth.

STAINLESS STEEL SURFACES: To maintain appliance frame's high quality appearance, wash with mild detergent and warm soapy water. Wipe dry with a soft cloth after each use.

AFTER EACH USE

Ensure that any part of the appliance that gets hot and experiences grease build up is cleaned before next use. Otherwise, a fire could occur.



STORAGE

- In order to extend and maintain the life and condition of your appliance, we strongly recommend that the unit be covered when left outside for any length of time, especially during the winter months.
- Take care to always completely dry your appliance before storing and keep away from rain and sprinklers.
- Cover the burners with aluminum foil in order to prevent insects or other debris from collecting in the burner holes.
- When gas supply is connected to appliance, store appliance outdoors in a well-ventilated space and out of reach of children.
- Store appliance indoors **ONLY** if gas supply is turned off, disconnected, removed from appliance and stored outdoors.
- When removing appliance from storage, clean burner assembly before starting appliance. (Please reference the Cleaning the Burner Assembly section.)

VALVE CHECK

Ensure gas is off at the supply shut off valve before checking appliance valves. Knobs must be turned to OFF position.

STEP 01 To check valves, push in knobs and release. Knobs should spring back.

If knobs do not spring back, replace valve assembly before using appliance.

STEP 02 Rotate knobs to LOW position then turn back to OFF position. Knobs should turn smoothly.

COVER FIT GUIDE

Visit us online at blackstoneproducts.com/support to find a cover that will fit your appliance.





WARNING

Ensure that the fuel nozzle is housed within the burner opening.

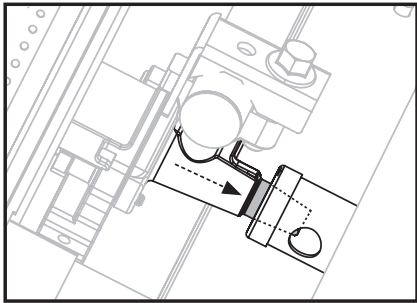

Section 02

CLEANING THE BURNER ASSEMBLY

Unit burners vary, however these instructions apply to all units. Clean burner assembly and check burner for damage. If any large cracks or holes are found, replace burner.

STEP 01 Ensure that the gas is turned OFF at control knobs and gas supply. Remove the cooking top.

STEP 02 Carefully detach and remove the burner.



STEP 03 Run a narrow bottle brush through each burner tube several times. (DO NOT use wire brushes)

Additional Methods Include:

- a Run a stiff wire bent into a small hook through each burner tube several times.
- b Use an air hose to force air into burner tube and out burner ports. Check that air blows through each hole. (Wear eye protection)



VIDEO TUTORIAL

How to Clean Your Burner Tube | Blackstone Griddle



[youtube.com/watch?v=xKQTCrFCzf8](https://www.youtube.com/watch?v=xKQTCrFCzf8)



STEP 04 Brush entire outer surface of burner to remove grime.



STEP 05 Clean any blocked ports with stiff wire such as an open paper clip. Then, carefully replace burners and reattach.

VERY IMPORTANT: Burner tubes must be reengaged with the valve openings.

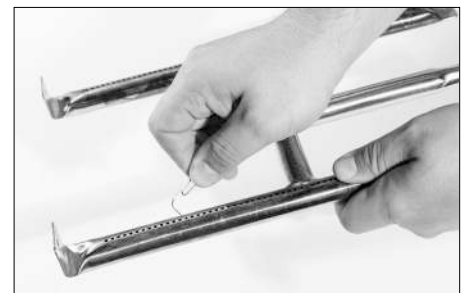



BURNER MAINTENANCE

In most circumstances, burning residue off after cooking will keep burner clean.

- Ensure that the flow of combustion and ventilation air is not obstructed.
- Burner should be removed and cleaned annually or whenever heavy build-up or insects/insect nests are found in order to ensure that there is no blockage in the burner portholes or venturi tubes.
- Use pipe cleaner to clear obstructions. A wire brush may be used to remove corrosion from the burner surfaces.

MATCH LIGHTING INSTRUCTIONS

Before beginning, check for gas leaks. (Please reference the Leak Test Instructions in the Fuel chapter.)

STEP 01 Ensure control knob is in OFF position.

STEP 02 Remove cooking top.

STEP 03 Light a match (or long lighter) no shorter than 11 inches long. Place the flame on the right or left side of the burner.

STEP 04 Push in and turn the control knob to the HIGH position. Ensure burner lights and stays lit.

BURNER FLAME CHECK

Always check burner flame before use.

STEP 01 Light burners and rotate knobs from high to low. When knob is at high, flames should be larger than when knob is at low.

STEP 02 Perform burner flame check by looking below cooking top on the side of unit to view burners below.

If there is a sudden drop or low flame issue, please reference the Troubleshooting chapter.

⚠ WARNING

A clogged burner tube can lead to a fire beneath the appliance.

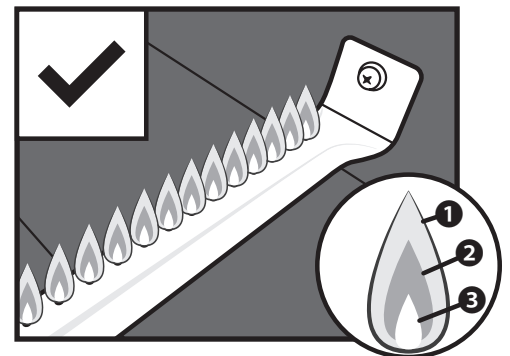
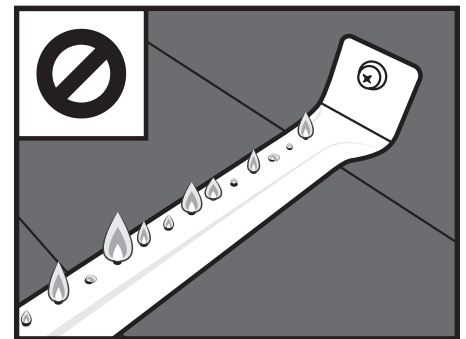

Healthy flames might have a few flickers of yellow color **1**, then a dark blue color **2**, followed by a vibrant blue by the burner tube **3**.



VIDEO TUTORIAL

How to Season a New Blackstone Griddle | Blackstone Griddle



[youtube.com/watch?v=VspmDVnj2pl&t=3s](https://www.youtube.com/watch?v=VspmDVnj2pl&t=3s)



PLEASE NOTE: Small variations in manufacturing and raw materials can cause some griddles to be slightly warped. A slight warp will disappear when the griddle is heated in preparation for cooking.

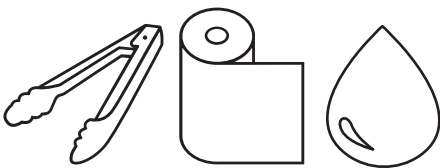

TOOLS NEEDED: Cooking tongs, Paper towels, and Cooking oil

Section 03

GRIDDLE SEASONING INSTRUCTIONS

For best results, we recommended seasoning the griddle before cooking on griddle top.

STEP 01 Make sure griddle top is wiped clean of debris. (For first time cleaning, please reference the Cleaning Your Griddle Top section.)

Blackstone griddle tops are pre-treated with soy oil as a protective coating. This coating may leave a discoloration on the griddle top. This is normal and will not affect the seasoning process.

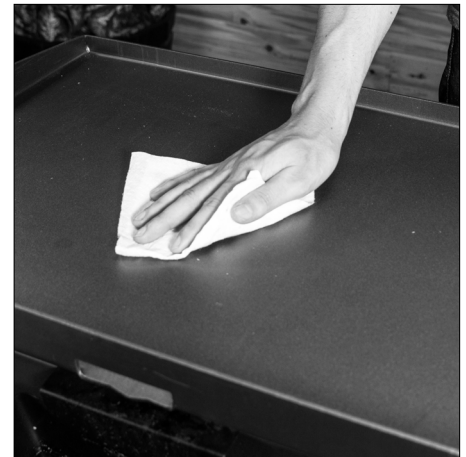

STEP 02 Set your griddle to high heat until your griddle top changes color. Use tongs to hold a paper towel or cotton cloth and spread 2-3 tablespoons of your seasoning oil across the griddle surface.

When seasoning your griddle top, remember to use a thin and even layer of oil—the thinner the layer of oil, the easier it will be to burn it off.

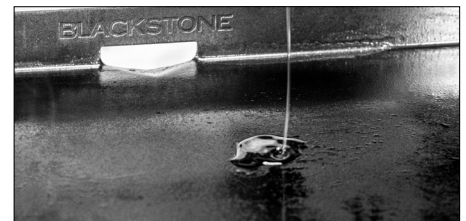

STEP 03 You will know it is done when it stops smoking. You will want to repeat this 3-4 times for your initial seasoning.

The heat of the griddle will break down the oil and bond it to the metal, creating a new polymer that acts as a stick resistant and protective layer over the griddle.





WHY DO I NEED TO SEASON MY GRIDDLE?

Seasoning leaves a hard protective layer bonded to the steel surface.

- Natural stick resistance.
- Prevents rust and corrosion.



⚠ CAUTION

Customers in humid or coastal climates may require more frequent seasonings and the use of heavier cooking oils to avoid rusting and corrosion.

GRIDDLE SEASONING TROUBLESHOOTING

SYMPTOMS

01. After seasoning, there is a brownish residue on the griddle surface.

POSSIBLE CAUSES

01. Too much oil was used.
02. You turned off the heat too soon.

SOLUTION

First, turn your griddle on high and let it heat for 10-15 minutes.

Next, scrape off as much of the thickened and partially cooked oil as you can.

Then, re-season with a very thin layer of oil.

SYMPTOMS

01. After seasoning, the griddle surface is not black.
02. Food is sticking to the griddle surface.

POSSIBLE CAUSES

01. The corners and edges do not have the same access to the direct heat of the burners, making it harder for the seasoning to darken like the rest of the griddle top.

SOLUTION

Apply a thin layer of oil between cooks to maintain seasoned cooking surface. (Please reference the Cleaning your Griddle Top section.)

After using your griddle for multiple cooks, the seasoning will even out and improve.

For further troubleshooting, please reference the Troubleshooting chapter.

For Frequently asked questions, visit blackstoneproducts.com/faq

WHAT OIL IS BEST TO USE?

The **Blackstone Seasoning and Cast Iron Conditioner** is the best and easiest way to get consistent results. This unique blend of oils combines the best of many different cooking oils.



Can I use any food grade oil?

Yes, but different oils can vary in the process from the burn time, smoke point, and durability once finished.

If you prefer to use an animal fat for seasoning, do not use bacon. Pure lard will work as it does not have the same additives as bacon.



⚠ DANGER

DO NOT place flammable items on side shelves near the griddle. Aerosol containers are particularly hazardous because **they can overheat and result in an explosion, fire, severe personal injury, or death.**

⚠ WARNING

DO NOT place oily or greasy towels near the griddle unit as they can spontaneously combust.

⚠ CAUTION

The grease cup must be removed and emptied after each use.

Do not remove the grease cup until the griddle has completely cooled.

ENGLISH

Section 04

CLEANING YOUR GRIDDLE TOP

Follow these simple cleaning steps to ensure optimal performance and longevity of your Blackstone Griddle.

STEP 01 To clean griddle after each use, cool griddle below 300° F. Scrape food debris with spatula or straight metal scraper.



STEP 02 Wipe down griddle surface with paper towel.



STEP 03 Divide griddle surface into approximately 6" sections (width of scraper tool). Apply a small amount of water onto first section with a bottle and then scrape the water and debris toward the grease trap. Move to the next 6" section and repeat.



DO NOT USE MORE THAN TWO TABLESPOONS OF WATER AT A TIME.

(For stuck-on food residue, use a bit of coarse salt.)

STEP 04 Wipe again with a paper towel and dry completely.



STEP 05 Apply thin coat of cooking oil to maintain seasoning and protect the griddle top.

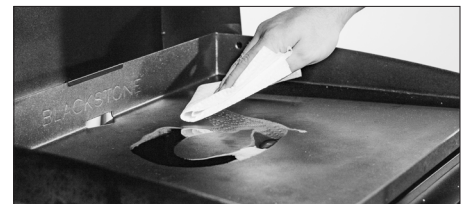

FOR EVERY GRIDDLE SURFACE

The **Blackstone Griddle Degreaser and Cleaning Spray** is gentle enough to clean every surface of your griddle. Use it on the griddle top, the griddle frame, or anywhere that experiences a build up of grease.





FIRST TIME CLEANING

Blackstone Griddles are pre-treated with cooking oil to prevent rust and damage during shipping. For first time use, wash griddle with hot, soapy water.

THIS IS THE ONLY TIME YOU SHOULD USE SOAP ON THE GRIDDLE COOKING SURFACE.

Rinse and dry completely. Proceed with seasoning instructions. (Please reference the Griddle Seasoning Instructions section.)

PROTECTING YOUR GRIDDLE TOP

Store griddle in a cool, dry location. Always cover griddle if stored outdoors. Choose from a variety of griddle covers offered by Blackstone.

When protecting griddle with soft cover, use the “tenting” method to prevent water from accumulating on griddle top. “Tenting” involves placing an object (a bowl, tennis ball or PVC pipe) beneath soft cover in the center of griddle in order to allow water to slide off. “Tenting” helps prevent rust.

CUTTING ON THE GRIDDLE TOP

Using a knife directly on the surface of the griddle will not harm the griddle top.

REMOVING RUST

If rust appears on the griddle surface, rub it off with steel wool, low grit sandpaper or the **Blackstone Pumice Stone** and re-season the surface.

Recovering your Blackstone Griddle Top



[youtube.com/watch?v=thPE2lgnSil](https://www.youtube.com/watch?v=thPE2lgnSil)

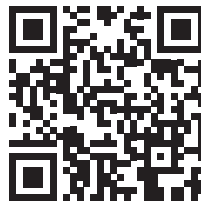

⚠ **WARNING**

NEVER APPLY COLD WATER ACROSS THE WHOLE SURFACE OF A HOT GRIDDLE AT ONCE. This may cause warping.

Adding a large amount of cold or frozen food (or food with significant water content) to a hot griddle may cause griddle to warp.

⚠ **CAUTION**

DO NOT USE SOAP ON THE GRIDDLE COOKING SURFACE. This will destroy the griddle's seasoning.

NEED HELP?

Register your Blackstone product at blackstoneproducts.com/register and visit us online at blackstoneproducts.com/support for replacement parts, assembly and operation questions.





⚠ WARNING

Do not clean the air fryer unit with a water spray or the like.

ENGLISH

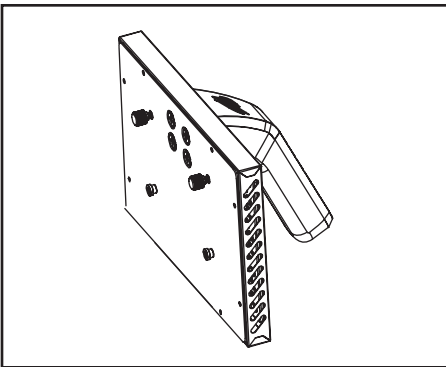

Keep the handle assembly with your Griddle, reassemble after the fryer drawer is clean and dry.

Section 05

CLEANING YOUR AIR FRYER

Your air fryer drawer is dishwasher safe. You will need to remove the handle assembly prior to placing in the dishwasher.

STEP 01 Loosen the top two (2) thumb screws and lift the handle assembly to remove from the fryer drawer. Do not remove the thumbscrews.

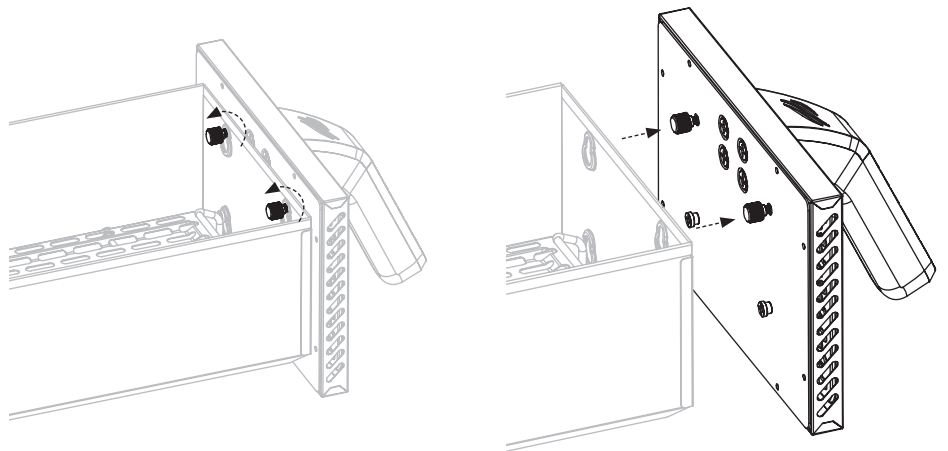

STEP 02 Remove the trivet from the air fryer drawer by lifting from the trivet handle up and out of the fryer drawer.

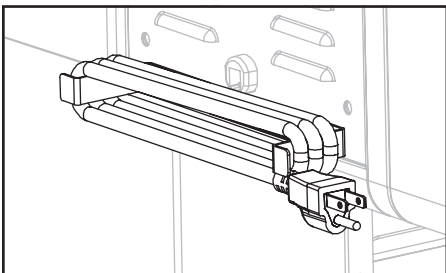

Wrap the power cord around the power cord bracket when the air fryer is not in use.

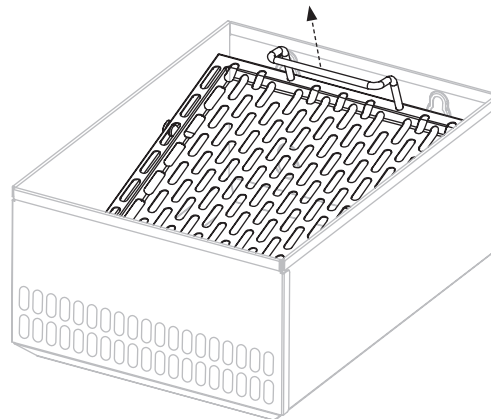



IGNITION | AIR FRYER

PROPANE AIR FRYER OPERATION

For proper ignition and operation of the air fryer follow the steps below.

STEP 01 In order for the ignitor button to work properly, ensure that the battery is installed correctly.

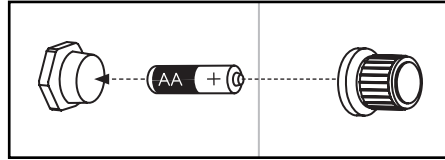

STEP 02

1 Ensure that the fryer control knob is turned to OFF.

STEP 03 Ensure that the LPG tank is properly connected to the unit. Turn gas ON at the LPG cylinder by slowly turning the OPD handwheel halfway.

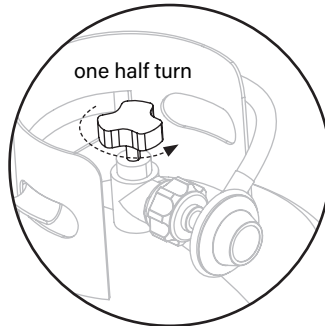

STEP 04

- 2 Push and hold the ignitor button.
- 3 Push and turn the fryer control knob counter-clockwise to MAX. (Release the ignitor button when the burner lights.)
- 4 Adjust the temperature to desired level.

LOW: 300°F - 375°F

MED: 375°F - 425°F

HIGH: 425°F - 475°F

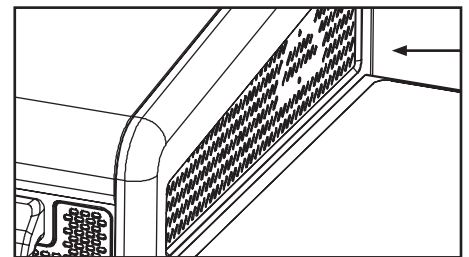
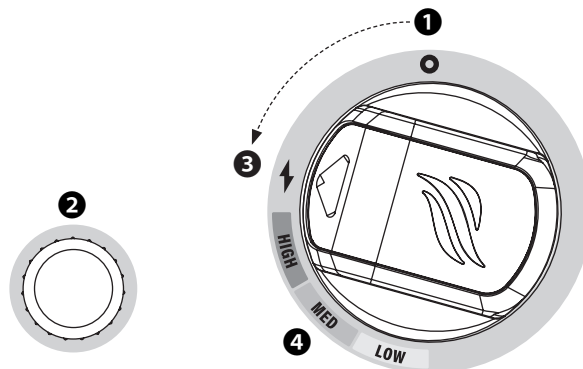

To verify that the air fryer burner has lit, look into the burner chamber from the right side of the unit.

STEP 05 Push the rocker switch to power ON, the blower fan will start immediately.

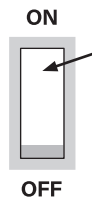

**⚠ WARNING**

Do not lean over the appliance while lighting.

⚠ WARNING

If ignition does NOT occur in 5 seconds, turn burner controls OFF, wait 5 minutes and repeat lighting procedure.

If burner does not ignite with open valve, gas will continue to flow out of burner and could accidentally/inadvertently ignite with risk of injury.

IGNITION | BATTERY POWERED

PROPANE BURNER OPERATION

For proper ignition and operation of the appliance follow the steps below.

STEP 01 In order for the ignitor button to work properly, ensure that the battery is installed correctly.

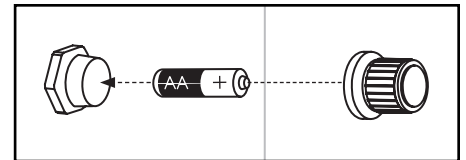

STEP 02

1 Ensure that the control knob is turned to OFF.

STEP 03 Ensure that the LPG tank is properly connected to the unit. Turn gas ON at the LPG cylinder by slowly turning the OPD handwheel halfway.

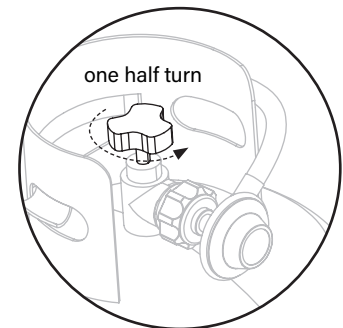

STEP 04

- 2 Push and hold the ignitor button.
- 3 Push and turn the control knob counter-clockwise to HIGH. (Release the ignitor button when the burner lights.)
- 4 Adjust the temperature to desired level.

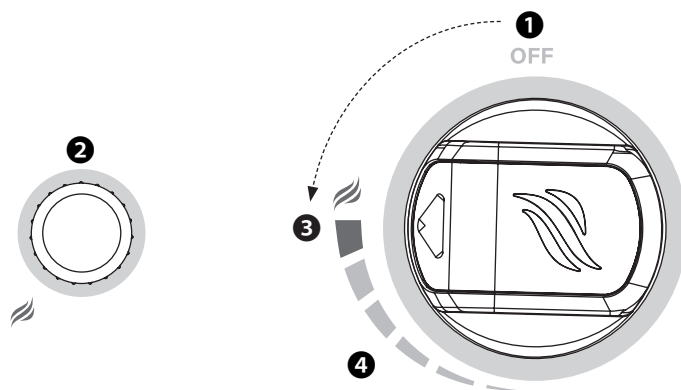



TROUBLESHOOTING

Visit BLACKSTONEPRODUCTS.COM/SUPPORT for additional troubleshooting.

Section 01

BATTERY POWERED IGNITION

SYMPTOMS

- 01. Burner will not Light with ignition system
- 02. Pressing the ignitor button does not result in a clicking sound

If ignition does not occur in 5 seconds, turn the burner controls off, wait 5 minutes and repeat the lighting procedure.

If this does not work, to determine the cause, please try to ignite your griddle with a match. (Please reference the Match Lighting Instructions in the Cleaning the Burner Assembly section of the Care & Maintenance chapter.)

If you CAN ignite your griddle with a match

POSSIBLE CAUSES	SOLUTION
01. Dead battery or no battery.	Replace with new battery.
02. Battery installed incorrectly.	Ensure that the battery is installed negative end first.
03. Ignitor wire misaligned.	Ensure that the ignition needle is positioned 1/8" to 1/4" away from the burner tube, positioned above a burner hole.
04. Damage to the ignition system.	Contact customer service for replacement parts.

If you CAN NOT ignite your griddle with a match

POSSIBLE CAUSES	SOLUTION
05. Burner tubes are not receiving fuel.	Please reference the Gas Flow section of the Troubleshooting Chapter.

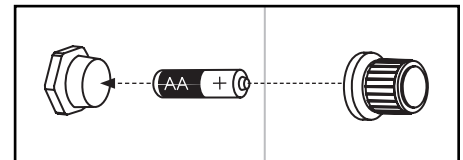

Insert one (1) AA battery (not included) into the battery socket with the positive terminal facing out, then screw on the ignitor button until tight. Be careful to not over tighten.

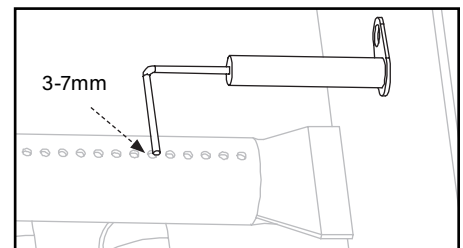

Ensure that the ignition needle is positioned 3-7mm away from the burner tube, positioned above a burner hole.



Section 02 GAS FLOW

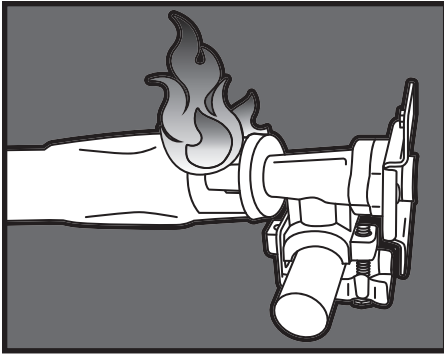

SYMPTOMS

- 01. A flame is coming out of the air gate.

POSSIBLE CAUSES

- 01. Something is blocking the venturi in the burner tube. This is not allowing the propane to flow through the burner, causing the flame to back out the air gate.

SOLUTION

Clean the burner assembly to remove the obstruction. (Please reference the Cleaning the Burner Assembly section of the Care & Maintenance chapter.)

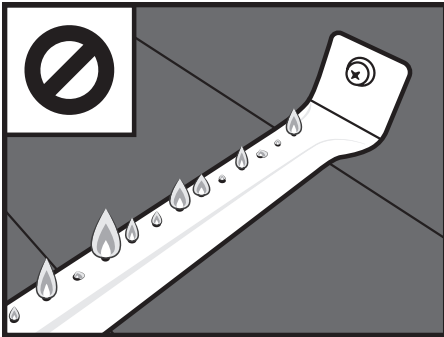

SYMPTOMS

- 01. Burner flames are yellow or irregular.

POSSIBLE CAUSES

- 01. Something is blocking the air gate for the burner. This is blocking oxygen from mixing with the propane correctly to get healthy flames.

SOLUTION

Check the air gates in your burner. If you have adjustable air shutters over your air gates, make sure that they are completely open. If your burners have bug shields, clean any spider webs, soot, or debris off the bug shield. Clean any other obstructions out of air gates.

TECHNICAL SUPPORT:

Scan QR code for more videos or visit the Blackstone YouTube channel at youtube.com/blackstonegriddles

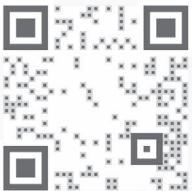



SYMPTOMS

- 01. Appliance will not achieve a high heat or heats unevenly.
- 02. Burner flames start strong, then immediately drop to low even when burner is set to high position.
- 03. Flame height drops when a second burner is lit.
- 04. Flames do not extend the full length of the burner, or only run on one side of the burner.
- 05. Burner flames are inconsistent.

POSSIBLE CAUSES

SOLUTION

<p>01. United States regulations require that all regulators contain a flow limiting device for consumer safety. This device measures the amount of propane going through the regulator to ensure the levels are safe. If the flow rate through the regulator is too high (a symptom of a large leak), the flow limiting device will trigger, restricting the flow of propane to reduce the chance of a dangerous fire. This safety system can accidentally be tripped by opening a propane tank too quickly or opening the propane tank when a burner knob is not in the off position.</p>	<p>This safety system can be reset by moving the burner knobs to the off position, closing the propane tank, and disconnecting the regulator from the propane tank. Wait five minutes to allow the pressure to dissipate, then reconnect the regulator to the propane tank and slowly open the OPD handwheel one half turn. Ignite your appliance as described in the Care & Maintenance chapter.</p>
<p>02. LP gas cylinder is empty or low.</p>	<p>Refill or replace the propane tank.</p>
<p>03. Obstructions in the burner, gas jets, or fuel rail.</p>	<p>Clean the burner, jets, and gas hose. (Please reference the Cleaning the Burner Assembly section of the Care & Maintenance chapter.)</p>
<p>04. Regulator stuck in safety position.</p>	<p>Contact customer service for replacement parts.</p>

BURNER FLAME PATTERN

Your appliance's burners are designed to mix oxygen and propane at a rate that allows for optimal flames. Should the burner's holes, air gate, or venturi get blocked, it will affect the propane and air mixture, causing low or inconsistent flames, or flames coming from the air gate.

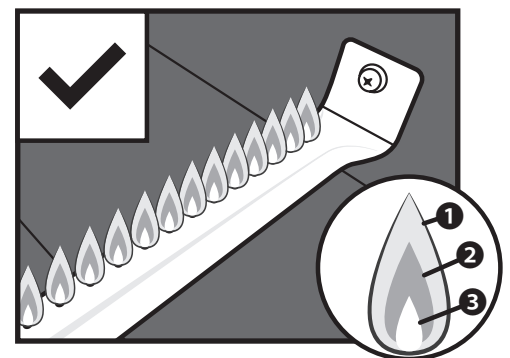

Healthy flames might have a few flickers of yellow color ①, then a dark blue color ②, followed by a vibrant blue by the burner tube ③.



RECIPES FOR LUNCH & DINNER

OKLAHOMA FRIED ONION BURGER

Serves 4 | 7 min.

Ingredients

- 1/2 lb of 80/20 ground beef
- 1 Vidalia (or sweet) onion (sliced paper thin)
- 4 slices American cheese
- 1/4 cup of dill pickle chips
- Salt

STEP 01 Pre-heat your Blackstone to high heat.

STEP 02 Make four 2 oz loosely packed meatballs with the ground beef and place on the hot griddle. Add a pinch of salt over each and using your **Blackstone Burger Press**, smash them very thin.

STEP 03 Add 2-3 ounces of thinly sliced onion over each patty.

STEP 04 Cook for 60-90 seconds and flip so that the onion's are under the patty. Add 1 slice of American cheese to each patty and then place the top bun over the cheese and then the bottom bun on top of the top bun. Cook for another 60 seconds.

STEP 05 To plate, remove the bottom bun from the top, using your spatula, lift the burger with top bun and add to the bottom bun.

STEP 06 Serve hot with a few dill pickle chips.

VIDEO RECIPES:

Find more inspiration and recipes at



[blackstoneproducts.com/
blogs/recipes](https://blackstoneproducts.com/blogs/recipes)



[youtube.com/c/
BlackstoneGriddles](https://youtube.com/c/BlackstoneGriddles)



@blackstoneproducts



NORTH ATLANTIC IMPORTS LLC 3-YEAR WARRANTY

North Atlantic Imports, the manufacturer, will warranty for three years from purchase all parts, workmanship, and finishes. It will be the manufacturer's option as to whether to repair or replace any of the above items. All warranties are limited to the original purchaser only. This warranty does not cover any liability on the part of North Atlantic Imports, its agents or employees, for any indirect or consequential damages for breach of warranty. The purchaser must follow the manufacturer's usage instructions.

Under no circumstances is the manufacturer responsible for damages from the failure to operate the cooking station properly. It is the responsibility of the purchaser to establish the warranty period by verifying the original purchase date with original sales receipt.

For more detailed explanation of the warranty, read below:

North Atlantic Imports LLC warrants to the owner that the product covered by this agreement is free from defects in material and workmanship under normal use and service for which it was intended if, but only if, it has been operated in accordance with North Atlantic Imports LLC instructions exclusively for domestic use, and not for private or public club, institutional or commercial purposes.

North Atlantic Imports LLC's obligation under this warranty is limited to replacing or repairing, free of charge, any part or parts that may prove, to the satisfaction of North Atlantic Imports LLC, to be defective under normal home use and service within the following stated periods of time from the date of purchase; for one year from purchase, all parts, finish, and workmanship. Should any failure to conform to this warranty become apparent during applicable warranty periods stated above, the original purchaser must notify North Atlantic Imports LLC of breach of warranty within the applicable warranty period.

North Atlantic Imports LLC shall upon notice and compliance by the original purchaser with such instructions, correct such nonconformity by repair or replacement of the defective part or parts.

Correction in the manner provided above shall constitute a fulfillment of all obligations of North Atlantic Imports LLC with respect to the quality of the product.

North Atlantic Imports LLC does not warrant this equipment to meet the requirement of any safety code of any state, municipality or other jurisdiction, and the original purchaser assumes all risk and liability whatsoever resulting from the use thereof, whether used in accordance with North Atlantic Imports LLC instructions or otherwise.

This warranty does not cover and is intended to exclude any liability on the part of North Atlantic its agents, servants or employees whether under this warranty or implied by law for any indirect or consequential damages for breach on any warranty. The purchaser must

establish all applicable warranty periods pursuant to this warranty by verifying the original purchase date by producing the dated sales receipt. This warranty shall not apply to this product or any other part thereof which has been subject to accident, negligence, alteration, abuse, or misuse or which has been repaired or altered without North Atlantic written consent, outside of North Atlantic Imports LLC factory. The full manufacturer warranty is not valid for griddles purchased from unlicensed, third-party resellers, purchased at a discount due to missing or damaged parts, or purchased as a floor model; at the discretion of North Atlantic Imports.

North Atlantic Imports LLC makes no warranty whatsoever in respect to accessories or parts not supplied with it. This warranty shall apply only within the boundaries of the United States of America. This warranty gives the original purchaser specific rights, and the original purchaser may also have other rights, which vary from state to state.

