



**TRAVIS INDUSTRIES
HOUSE OF FIRE**

Small Flush Wood Insert

(Arched or Rectangular)

with Hybrid-Fyre™ Technology

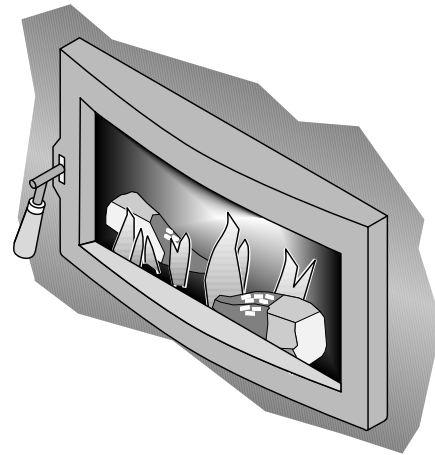
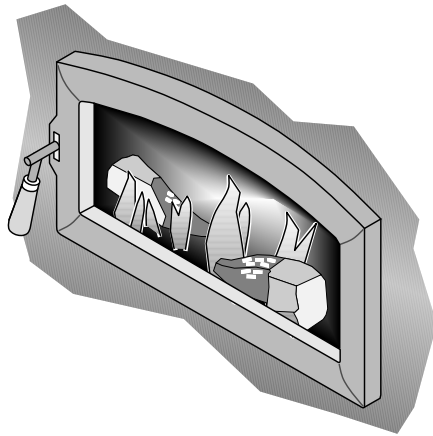

Owner's Manual

- **Masonry Fireplace Insert**
- **Zero-Clearance (Metal) Fireplace Insert**

Save these instructions for future reference

WARNING



**HOT GLASS WILL
CAUSE BURNS.
DO NOT TOUCH GLASS
UNTIL COOLED.
NEVER ALLOW CHILDREN
TO TOUCH GLASS.**

SAFETY NOTICE:

If this appliance is not properly installed, a house fire may result. For your safety, follow the installation directions. Contact local building or fire officials about restrictions and installation inspection requirements in your area.

Travis Industries, Inc.

12521 Harbour Reach Drive
Mukilteo, WA 98275
www.travisproducts.com

© Copyright 2015, T.I.
\$10.00 100-01342
4150521



c LISTED US

Listed

Intertek

Tested to: U.L. 1482 & ULC S628

Introduction

We welcome you as a new owner of a Small Flush Wood Insert. In purchasing a Small Flush Wood Insert you have joined the growing ranks of concerned individuals whose selection of an energy system reflects both a concern for the environment and aesthetics. This insert is one of the finest appliances the world over. This manual will explain the installation, operation, and maintenance of this appliance. Please familiarize yourself with the Owner's Manual before operating your appliance and save the manual for future reference. Included are helpful hints and suggestions which will make the installation and operation of your new appliance an easier and more enjoyable experience. We offer our continual support and guidance to help you achieve the maximum benefit and enjoyment from your appliance.

Important Information

No other Small Flush Wood Insert appliance has the same serial number as yours. The serial number is stamped onto the label on the back of the appliance.

This serial number will be needed in case you require service of any type.

Model: Small Flush Wood Insert

Serial Number: _____

Purchase Date: _____

Purchased From: _____

Register your warranty online at:

traviswarranty.com

Save Your Bill of Sale.

To receive full warranty coverage, you will need to show evidence of the date you purchased your heater.

We suggest that you attach your Bill of Sale to this page so that you will have all the information you need in one place should the need for service or information occur.



We suggest that our woodburning hearth products be installed and serviced by professionals who are certified in the U.S. by the National Fireplace Institute® (NFI) as NFI Woodburning Specialists or who are certified in Canada by Wood Energy Technical Training (WETT).



<u>Introduction</u>	<u>2</u>	Approximate Air Control Settings:	25
<u>Important Information.....</u>	<u>2</u>	<u>Understanding Your Heater’s Combustion System</u>	<u>26</u>
<u>Installation Options.....</u>	<u>6</u>	<u>Burning Your Heater.....</u>	<u>26</u>
<u>Features</u>	<u>6</u>	<u>Blower Operation.....</u>	<u>27</u>
<u>Heating Specifications.....</u>	<u>6</u>	<u>Re-Loading the Stove.....</u>	<u>27</u>
<u>Dimensions.....</u>	<u>6</u>	<u>Overnight Burn.....</u>	<u>27</u>
<u>Emissions and Efficiency.....</u>	<u>6</u>	<u>Normal Operating Sounds</u>	<u>27</u>
<u>Planning the Installation.....</u>	<u>7</u>	<u>Hints for Burning</u>	<u>28</u>
Preparation for Installation	7	<u>Selecting Wood.....</u>	<u>28</u>
Additional Accessories Needed for Installation	7	Why Dry Wood is Key	28
Packing List.....	7	Wood Cutting and Storage.....	28
Additional Requirements for Canada	7	Do Not Burn List.....	29
<u>Fireplace Requirements</u>	<u>8</u>	<u>Troubleshooting.....</u>	<u>30</u>
<u>Fireplace Altered Tag.....</u>	<u>8</u>	<u>Daily Maintenance (while stove is in use) ...</u>	<u>31</u>
<u>Insert Placement Requirements</u>	<u>9</u>	Remove Ash (if necessary)	31
<u>Hearth Requirements.....</u>	<u>10</u>	Clean the Glass (if necessary)	31
USA	10	<u>Monthly Maintenance (while appliance is in use).....</u>	<u>32</u>
CANADA.....	10	Door and Glass Inspection.....	32
<u>Masonry Fireplace Requirements</u>	<u>10</u>	Door Latch Adjustment	32
<u>Zero-Clearance (Metal) Fireplace Requirements</u>	<u>11</u>	Creosote - Formation and Need for Removal	32
<u>Drafting Performance</u>	<u>12</u>	Cleaning the Catalytic Combustor.....	33
<u>Leveling Bolt Installation.....</u>	<u>12</u>	<u>Yearly Maintenance</u>	<u>34</u>
<u>Flue Adapter Installation</u>	<u>13</u>	Touch-Up Paint	34
<u>Vent Overview</u>	<u>17</u>	Cleaning the Air Duct and Blower (if applicable) .	34
<u>Surround Panel Installation</u>	<u>18</u>	Firebrick and Baffle Inspection.....	34
<u>Face Installation and Removal</u>	<u>18</u>	<u>Door Parts.....</u>	<u>35</u>
<u>Re-Routing the Electrical Cord to the Left Side.....</u>	<u>19</u>	Replacing the Glass.....	35
<u>Safety Notice</u>	<u>20</u>	Replacing the Door Gasket	35
<u>Before Your First Fire</u>	<u>20</u>	<u>Blower and Electrical Parts</u>	<u>35</u>
Verify the Installation.....	20	<u>Firebox Parts</u>	<u>36</u>
Curing the Paint	20	Baffle Parts	36
Over-Firing the Stove.....	20	Baffle Removal.....	36
<u>Opening the Door</u>	<u>21</u>	Combustor	36
<u>Bypass Operation</u>	<u>22</u>	<u>Air Tube Removal & Replacement.....</u>	<u>37</u>
<u>Maintaining Catalytic Burn-Off</u>	<u>22</u>	Brick Removal & Replacement	38
<u>Catalytic Combustor – Use and Cleaning....</u>	<u>23</u>	<u>GreenStart™ Igniter – Firebrick and Housing Installation.....</u>	<u>39</u>
Inspecting & Cleaning the Combustor.....	23	Minimum Fireplace Size.....	39
<u>Starting a Fire</u>	<u>24</u>	Igniter Firebrick and Housing	39
<u>Adjusting the Burn Rate</u>	<u>25</u>	39
		Listing Label.....	43

Safety Precautions

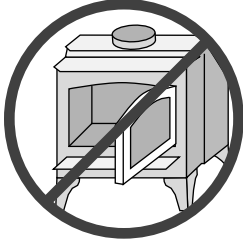

The viewing door must be closed and latched during operation.

Smoke from this appliance may activate a smoke detector when the door is open.

Never block free airflow through the air vents on this appliance.



Gasoline or other flammable liquids must never be used to start the fire or "Freshen Up" the fire. Do not store or use gasoline or other flammable liquids in the vicinity of this appliance.



This appliance is designed and approved for the burning of cord wood only. Do not attempt to burn any other type of fuel other than cord wood in this appliance, it will void all warranties and safety listings.



Ashes must be disposed in a metal container with a tight lid and placed on a non-combustible surface well away from the home or structure.



Do not touch the appliance while it is hot and educate all children of the danger of a high-temperature appliance. Young children should be supervised when they are in the same room as the appliance.

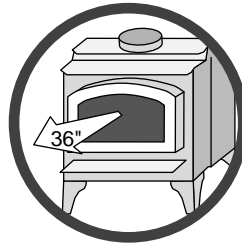

Keep furniture, drapes, curtains, wood, paper, and other combustibles a minimum of 36" away from the front of the appliance.



This appliance must be properly installed to prevent the possibility of a house fire. The instructions must be strictly adhered to. Do not use makeshift methods or compromise in the installation.



Contact your local building officials to obtain a permit and information on any installation restrictions or inspection requirements in your area. Notify your insurance company of this appliance as well.



Inspect the chimney connector and chimney at least twice monthly and clean if necessary. Creosote may build up and cause a house fire.

Do not connect this appliance to any chimney serving another appliance.

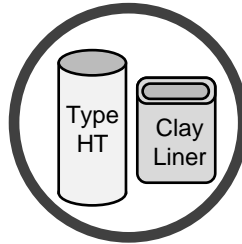

This appliance must be connected to a listed high temperature (UL 103 HT) residential type chimney or an approved masonry chimney with a standard clay tile, or stainless steel liner.



Never try to repair or replace any part of this appliance unless instructions are given in this manual. All other work must be done by a trained technician. Do not make any changes or modifications to an existing masonry fireplace or chimney to install this appliance.

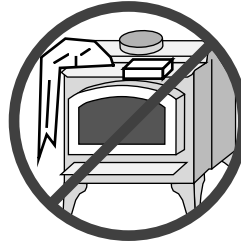

Do not place clothing or other flammable items on or near this appliance.

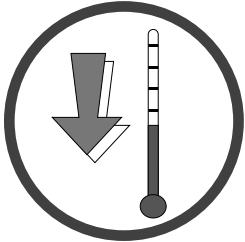

Allow the appliance to cool before carrying out any maintenance or cleaning.

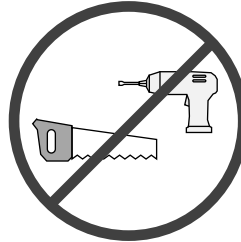

This wood heater has a manufacturer-set minimum low burn rate that must not be altered. It is against federal regulations to alter this setting or otherwise operate this wood heater in a manner inconsistent with operating instructions in this manual.



Maintain the door and glass seal and keep them in good condition.

Do not operate this heater with broken or missing glass.

Avoid placing wood against the glass when loading. Do not slam the door or strike the glass.

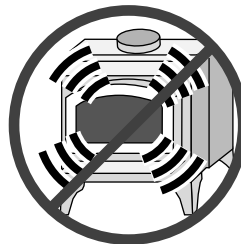

Over-firing the appliance may cause a house fire. If a unit or chimney connector glows, you are over-firing.



Do not throw this manual away. This manual has important operating and maintenance instructions that you will need at a later time. Always follow the instructions in this manual.

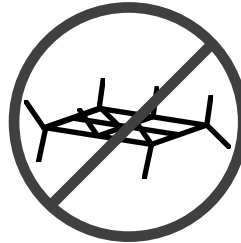

Do not use a grate or other device to elevate the fire off of the firebox floor. Burn the fire directly on the bricks.



Travis Industries, Inc. grants no warranty, implied or stated, for the installation or maintenance of your appliance, and assumes no responsibility of any consequential damage(s).

Smoke and CO Detectors: Make sure your home has a working smoke detector, especially near any bedrooms. We recommend having a smoke and/or CO detector in the same room as the wood heater for additional safety.

Proposition 65 Warning: Fuels used in gas, woodburning or oil fired appliances, and the products of combustion of such fuels, contain chemicals known to the State of California to cause cancer, birth defects and other reproductive harm. California Health & Safety Code Sec. 25249.6

Installation Options

- Masonry Fireplace Insert
- Zero-Clearance (Metal) Fireplace Insert

Features

- 1.2 Cubic Foot Firebox Volume
- Single Air Control
- Accepts Logs Up to 18" Long
- Steel Plate Construction (Up to 5/16")
- Heavy Duty Refractory Firebrick
- Standard High-Tech Blower

Heating Specifications

Approximate Maximum Heating Capacity (in square feet)*	650 to 1,000
Maximum BTUs per Hour (Cord Wood Calculation)	47,000
Maximum Burn Time	Up to 7 Hours

* Heating capacity will vary depending on the home's floor plan, degree of insulation, and the outside temperature. It is also affected by the quality and moisture level of the fuel.

This model was tested for efficiency using method B415.1-10 and was determined to have a weighted average Higher Heating Value (HHV) Overall Heating Efficiency (OHE) of 76.5%.

Dimensions

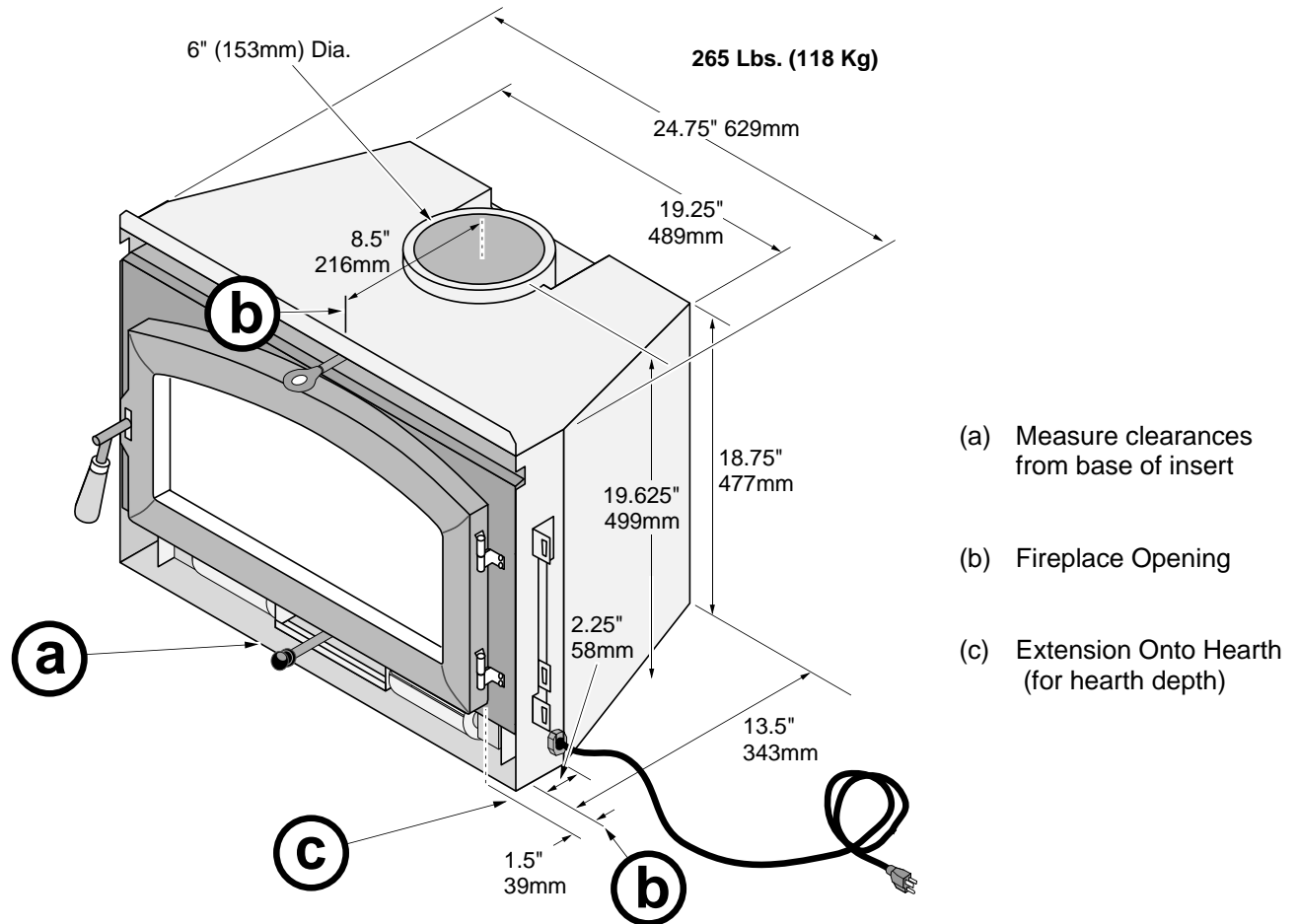

Emissions and Efficiency

This heater meets the 2015 U.S. EPA's crib wood emission limits for wood heaters sold after May 15, 2015. Tested to Method 28, 5G2 this heater has been shown to deliver heat at rates ranging from 9,800 to 31,400 BTU/hr and an emission value of 0.89g/h.

SAFETY NOTICE:

Please read this entire manual before you install and use your new room heater. Failure to follow instructions may result in property damage, bodily injury, or even death. Contact local building or fire officials about restrictions and installation inspection requirements in your area.

Planning the Installation

We suggest that you have an authorized Travis Industries dealer install your fireplace insert. If you install the fireplace insert yourself, your authorized dealer should review your installation plans.



Check with local building officials for any permits required for installation of this fireplace insert and notify your insurance company before proceeding with installation.



The location of your wood heater in your home will decide how affectively the heat produced will spread throughout your house. Attention to the home design with consideration of natural convection and air circulation should be taken into account when choosing the placement of your heater within the home.

Preparation for Installation

- Check for damage to the exterior of the fireplace insert (dents should be reported, scratches can be fixed by applying touch-up paint).
- Check the interior of the firebox (replace cracked firebrick and make sure baffle and combustor is in place).



The fireplace insert can be lightened by removing the firebricks (pg. 38) - replace before operation.

Additional Accessories Needed for Installation

- Face
- Surround Panels (see page18 for sizing)

Packing List

- Flue Attachment Gasket (with screws)
- Bypass Tool
- GreenStart Igniter FireBrick and Igniter Housing (used with GreenStart igniters only)
- Flue Alignment Tool
- Brush for Combustor
- Combustor Temperature Meter

Additional Requirements for Canada

- Do not remove bricks or mortar from existing fireplace.
- This fireplace insert must be installed with a continuous chimney liner of 6" diameter extending from the fireplace insert to the top of the chimney. The chimney liner must conform to the Class 3 requirements of CAN/ULC-S635, Standard for Lining Systems for Existing Masonry or Factory-Built Chimneys and Vents, or CAN/ULC-S640, Standard for Lining Systems for New Masonry Chimneys.
- Permanently seal any opening between the masonry of the fireplace and the facing masonry.
- Fireplace insert, or surround panels, may be removed to inspect fireplace insert and fireplace.
- Lock existing dampers in the open position.

Fireplace Requirements

The table below details minimum size requirements for the fireplace.

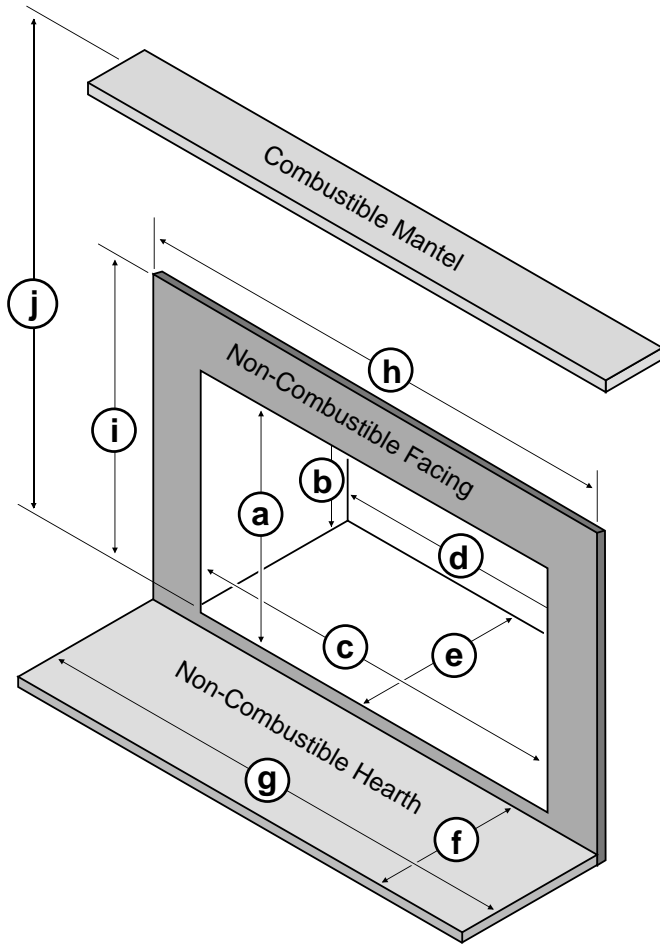

Minimum Fireplace Size	
a Height (front)	19" 483mm
b Height (rear)	19" 483mm
c Width (front)	27"* 686mm*
d Width (rear)	19.25" 489mm
e Depth	14" 356mm
f Hearth Depth (measured from fireplace opening)	17.5" 445mm (USA) 19.5" 496mm (Canada)
g Hearth Width	40.75" 1036mm
h Facing Width	37.25" 947mm
i Facing Height Above Base of Insert	37.5" 953mm
j Mantel Height Above Base of Insert	37.5" 953mm

* Includes 2" (51mm) for power cord installation and face brackets.

Fireplace Altered Tag

Attach the "This fireplace has been altered..." plate to the fireplace (use two screws or other suitable method). You may wish to place it in a location where it will be covered by the surround panels.

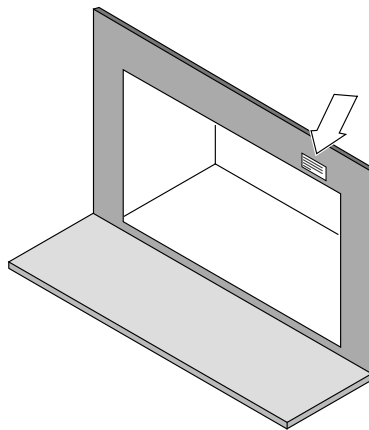

Insert Placement Requirements

- The insert must be placed so that no combustibles are within, or can swing within (e.g. drapes, doors), 36" (915mm) of the front of the insert (item "q" below).
- Insert and hearth must be installed on a level, secure floor
- The minimum clearances, facing, and hearth requirements listed below must be met.

Minimum Clearances	
k Sidewall	11.625" 296mm
l Side Facing (non-combustible)	6.25" 159mm
m Top Facing (non-combustible)	37.5" 953mm
n Mantel (combustible – maximum 12" 305mm deep)	37.5" 953mm
o Front Hearth	16" 407mm (USA)
	18" 458mm (Canada)
p Side Hearth	8" 204mm
q Front of Insert	36" 915mm
s Mantel Column (max. 8" 204mm deep)	6.25" 159mm
x Extension Onto Hearth	1.5" 39mm

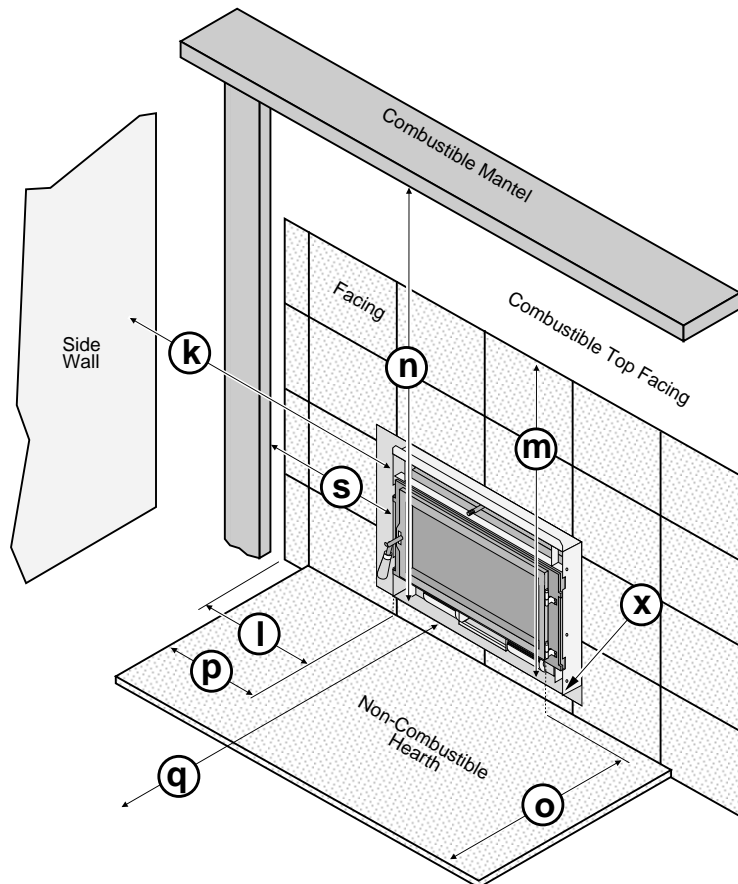

10 Fireplace Insert Installation (for qualified installers only)

Hearth Requirements

When installing into a masonry fireplace, the hearth must meet Uniform Building Code (UBC) standards.

USA

When installing into a zero-clearance fireplace, the hearth must extend 16" (407mm) to the front and 8" (204mm) to the sides of the insert. The hearth must provide an R-value (thermal resistance) of 1.19 or greater.

If the insert is a minimum 2" (51mm) above the combustible floor (carpet, wood, etc.) the hearth must extend 16" (407mm) in front and 8" (204mm) on both sides of the insert. Hearth must be non-combustible (cement board, tile, etc.). No R-value (thermal resistance) is required.

CANADA

When installing into a zero-clearance fireplace, the hearth must extend 18" (458mm) to the front and 8" (204mm) to the sides of the insert. The hearth must provide an R-value (thermal resistance) of 1.19 or greater.

If the insert is a minimum 2" (51mm) above the combustible floor (carpet, wood, etc.) the hearth must extend 18" (458mm) in front and 8" (204mm) on both sides of the insert. Hearth must be non-combustible (cement board, tile, etc.). No R-value (thermal resistance) is required.

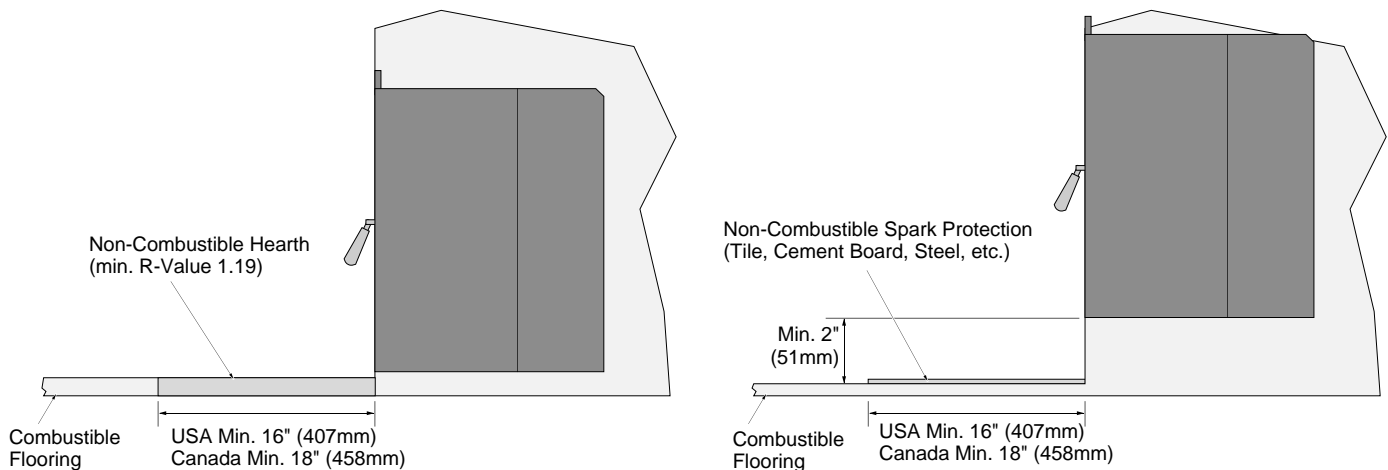

Masonry Fireplace Requirements

- Must utilize a positive connection (full reline)
- Entire fireplace, including chimney, must be clean and undamaged. Any damage must be repaired prior to installation of the insert.
- Chimney height: 15' (4.5M) minimum; 33' (10M) maximum (measured from base of insert).
- Entire fireplace, including chimney, must meet local building requirements.
- The fireplace insert must be placed on a masonry hearth built to UBC standards.

Zero-Clearance (Metal) Fireplace Requirements

- Must be manufactured by one of the following manufacturers:
 - Marco • Majestic • Heatilator • Preway • Tempco • Superior
 - Heat N Glo • Lennox • Martin • Monesson
- Entire fireplace, including chimney, must meet local building requirements
- Chimney height: 15' minimum; 33' maximum.
- The damper ("A") and grate ("B") must be removed (see illustration below). The smoke shelf ("C"), internal baffles ("D"), screen ("E"), and metal or glass doors ("F") may be removed (if applicable). The masonry lining ("G"), insulation ("H"), and any structured rigid frame members (metal sides, floor, door frame, face of the fireplace, etc. – "I") may not be removed or altered

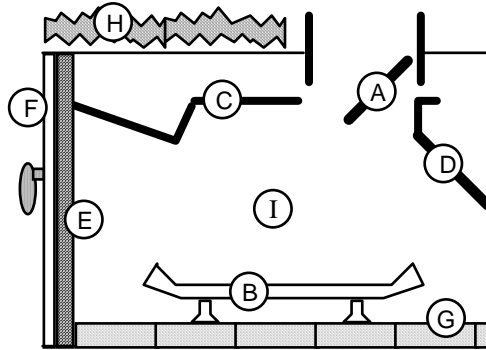

- The chimney on the ZC fireplace must be listed per UL 127 or ULC 610-M87 for all installations. Any thermal protection component of the fireplace or chimney must remain in place. The fireplace and chimney must be inspected prior to installation. A NFPA 211 Level II inspection is recommended. Repairs must be made prior to insert installation. The base of the fireplace must be structurally sound and able to support the weight of the insert.
- The stainless steel liner must be 6" diameter and extend the full height of the chimney (also called a positive connection or full re-line). This liner must meet type HT (2100°F) requirements per UL 1777 (USA) or ULC S635 with "0" clearance to masonry (Canada). The liner must be attached to the insert flue collar and to the top of the existing chimney.
- We recommend using the listed Travis ZC Liner Kit from Duravent (SKU 98900046, 47, or 48). If you do not use this kit, you must use the original ZC chimney cap.
- The liner support and cap at the top of the chimney must not reduce air flow for the existing air-cooled chimney system. The Travis ZC Liner Kit includes a cap that meets this provision.
- To prevent air from passing up the ZC fireplace chimney (the gap between the liner and chimney) we recommend sealing the area near the damper. Use non-combustible material to seal this area (non-backed fiberglass insulation or kaowool).
- The convection air channel on the fireplace must not be blocked. Do not block any louvers, grills, or air passages on the front of the fireplace.
- Entire fireplace, including chimney, must meet local building requirements. Permits may be required for installation. Final approval is contingent upon the authority having local jurisdiction. Inform you insurance agent of this fireplace insert.

12 Fireplace Insert Installation (for qualified installers only)

Drafting Performance

Draft is the force which moves air from the appliance up through the chimney. The amount of draft in your chimney depends on the length of the chimney, local geography, nearby obstructions and other factors. Too much draft may cause excessive temperatures in the appliance and may damage the heater. Inadequate draft may cause backpuffing into the room and 'plugging' of the chimney. Inadequate draft will cause the appliance to leak smoke into the room through appliance and chimney connector joints. An uncontrollable burn or excessive temperature indicates excessive draft.

Leveling Bolt Installation

MASONRY NOTE: Place a metal plate below the bolts on masonry fireplaces to prevent damage to the floor brick.

Two leveling bolts are pre-installed on the insert to allow for proper leveling within the fireplace. To access the bolts, remove the back corner firebricks and cover plates "a" and "b". The bolts are pre-threaded to a weld-nut on the base of the insert. Use a 3/4" socket wrench to screw the bolts down (clockwise) until the insert is level (see "c").

SEALING THE COVER PLATE: We recommend sealing the cover plate with furnace cement (place on underside of cover plate).

BOLT LENGTH: The included bolts allow approximately 1" of rise. If additional rise is required, use a longer 1/2-13 thread bolt. Make sure the additional bolt length does not interfere with the cover plate.

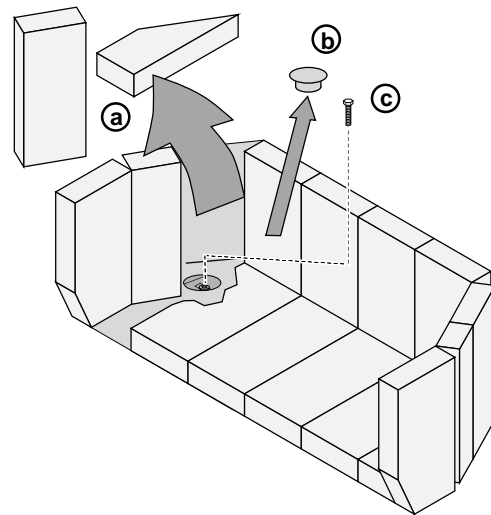

Figure 1

Flue Adapter Installation

The flue adapter may be removed, attached to the liner, then re-attached while the insert is placed in position.

1. Remove the two bolts that secure the flue adapter to the insert (7/16" Nutdriver).
NOTE: Flue adapter is tight and will need to be knocked loose with a hammer.



2. Prepare the liner connector for attachment to the flue adapter. Notch the liner around the bypass rod and check fit.



3. The liner adapter will fit loose in the flush wood insert flue collar and must be sealed with the gasket tape provided in the hardware pack with the insert. Start above the bypass rod notch and wrap the gasket twice around the liner adapter overlapping the second wrap over the top edge of the first wrap (shown below).



14

Fireplace Insert Installation (for qualified installers only)

4. Attach the liner adapter to the insert flue adapter and then locate correct connection position in the fireplace and attach to the liner. Make sure the adapter is centered, 8-1/2" behind the fireplace opening, and approximately 18" from the floor of the fireplace.

HINT: Placing the flue connector near its final position is key to an easy installation.



5. Slide the insert into place. Make sure the adapter fits over the opening for the flue.

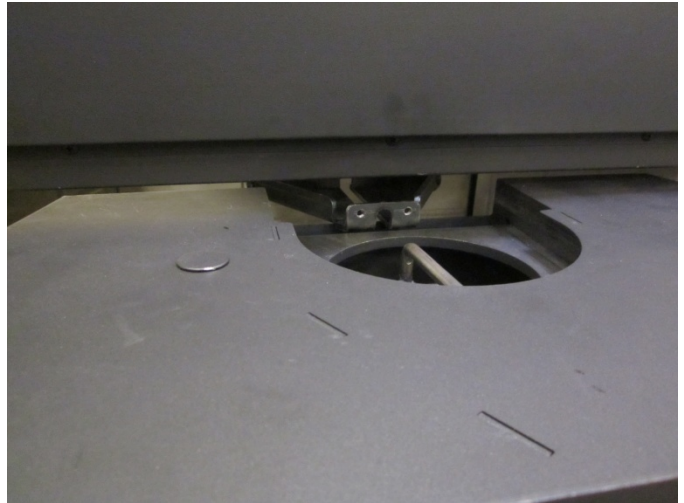

6. A flue adapter pull-stick is included to help position the flue adapter in place. Insert the pull stick through one of the holes for the flue adapter bolt.

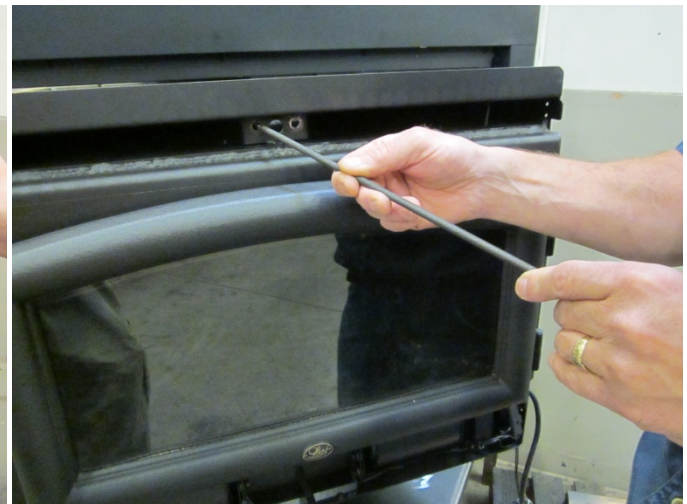
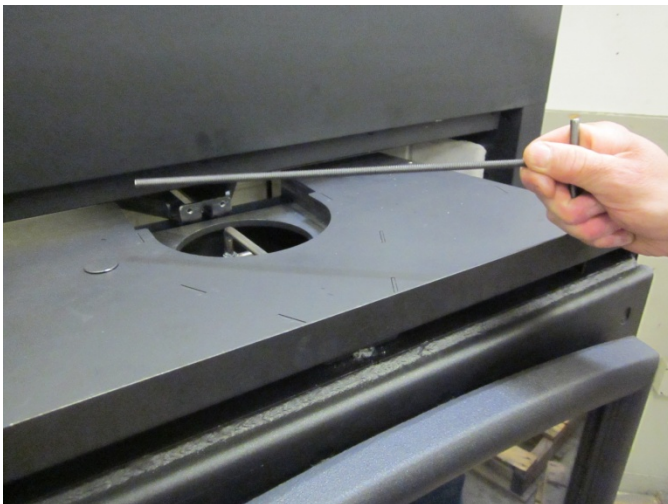

- 7 Thread the pull stick into the flue adapter and turn 4 to 6 times.



- 8 Use the pull stick to guide the flue adapter into position. Push the insert slightly, then pull on the pull stick.



- 9 Repeat step 8 until the insert is in position.



16 Fireplace Insert Installation (for qualified installers only)

10 Remove the pull stick and place it aside (behind surround panels, inside the fireplace for future use).

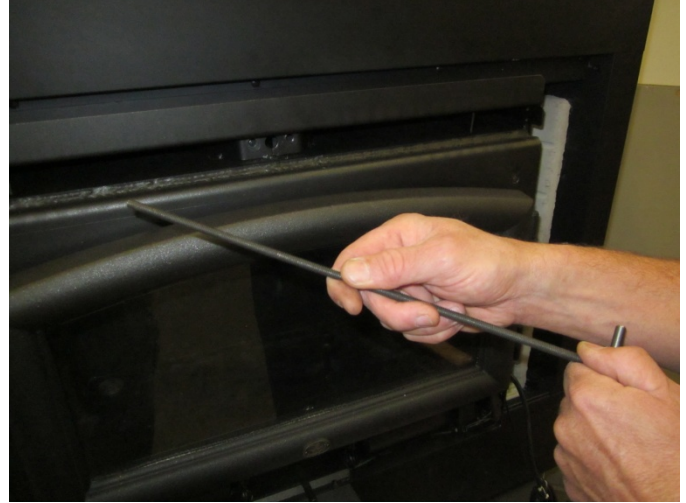

11 Replace the two bolts removed in step 1. Tighten the bolts fully, making sure the flue adapter is seated.



Vent Overview

This insert utilizes a catalytic combustor to increase efficiency and decrease emissions. This increases the air resistance inside the firebox, making the flue connection especially important. To insure proper draft, and to prevent smoke spillage during re-loading, **it is crucial for the flue to be sealed**. Use the included gasket to seal the liner connector to the flue adapter.

In addition, we recommend using non-combustible fiberglass insulation to seal the fireplace enclosure. By sealing the top and bottom of the chimney, and the surround panels, you will be ensuring outside air is not pulled into the chimney.

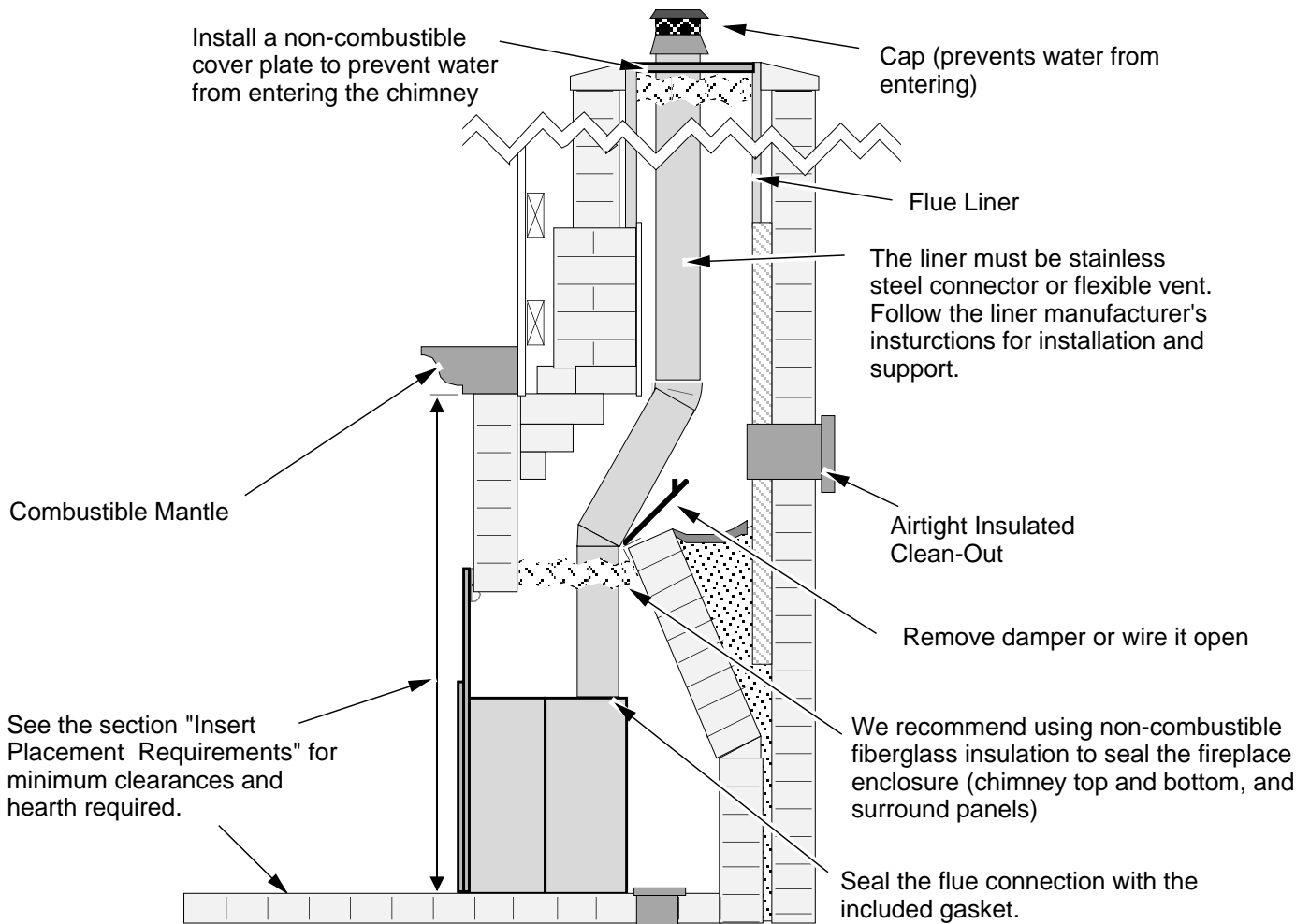

Surround Panel Installation

	Width	Height	Part#
Standard Size	38" (966mm)	25" (635mm)	96100409

When installing, lift the panel over this flange.

The surround panel is installed after the insert is in place with the flue attached. Make sure to route the power cord and rheostat wires through the notch in the panel.

NOTE: The surround panel is not required. If the fireplace opening is small enough, you may wish to use the face only (see dimensions below).

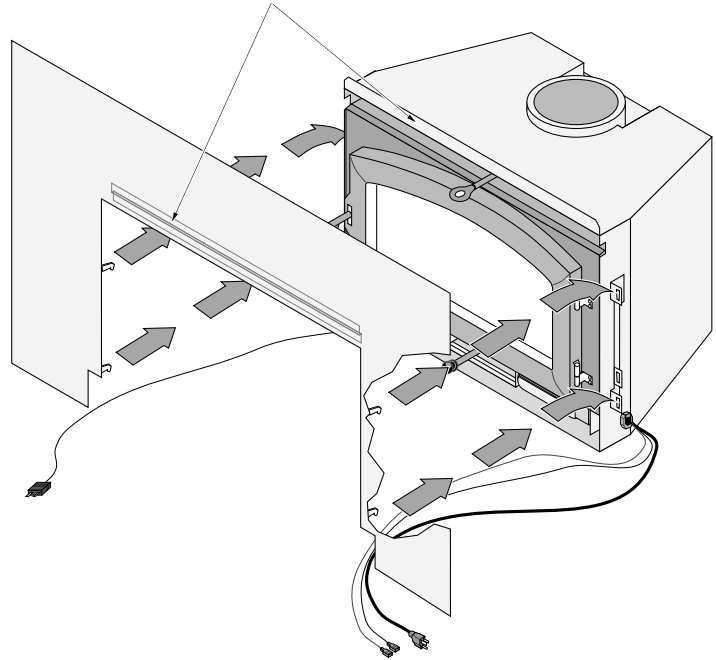

NOTE: When installing the panel, route the power cord and rheostat wires through the notch on the bottom of the panel (right side). Route the catalytic temperature probe wire through the notch on the left side. Make sure these wires do not become pinched or damaged during panel and face installation.

Face Installation and Removal

WARNING: Unplug or disable power to the appliance prior to removing the face.

- 1) Open the door and lift it off its hinges.
- 2) Pull the bypass all the way forward. Unscrew the bypass rod from the bypass yoke (make sure to detach the handle and rod as one piece).
- 3) Unscrew the air control rod from the air control.
- 4) The face uses hooks to hang in place. Lift the face up and pull back to remove. Take care to prevent damage to the wiring (disconnect if necessary).

See the instructions included with the face for full details.

FACE SIZING: 30" Wide, 21.5" Tall

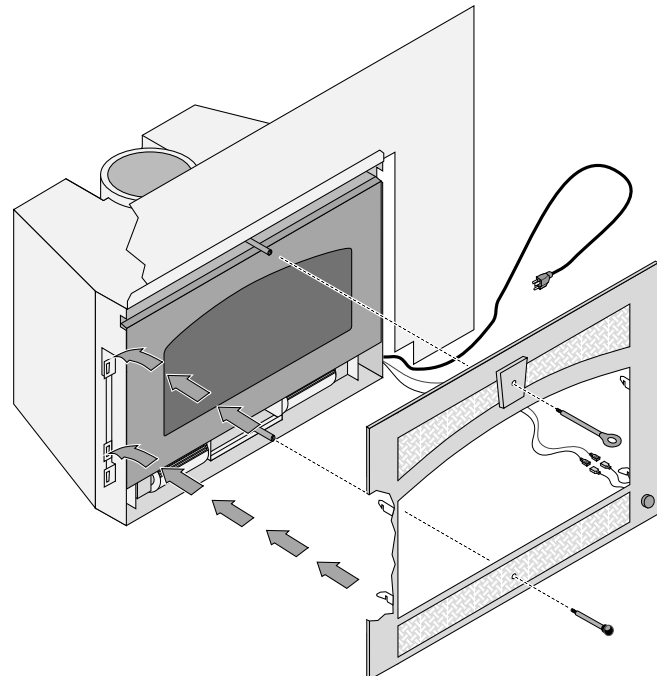

Re-Routing the Electrical Cord to the Left Side

The power cord is connected to the right side of the insert when it leaves the factory. It may be re-routed to the left side following the directions below. Do this procedure before installing the surround panels.

- 1 Disconnect the Molex connector and remove the power cord following the directions below.

Disconnect the molex connector leading from the power cord.

Rheostat Wires

Power Cord

Use pliers to compress the strain relief from the top and bottom while pulling it out of the hole in the side of the insert.

Leave the rheostat wires in place.

Remove the power cord.

NOTE: An additional knockout is provided if using the insert wiring kit. Route the power through one hole, the rheostat through the other.

Make sure the power cord is disconnected prior to conducting these steps.

- 2 Connect the power cord to the left side following the directions below.

Attach the molex connector on the power cord to the molex connector on the left side of the insert.

Power Cord

Re-attach the strain relief to the left side (use pliers to compress the strain relief from the top and bottom while pushing it into the hole).

Remove the button plug from the left side.

Safety Notice



If this appliance is not properly installed, a house fire may result. For your safety, follow the installation directions. Contact local building or fire officials about restrictions and installation inspection requirements in your area.



Read and follow all of the warnings on pages 4 and 5 of this manual.

Before Your First Fire

Verify the Installation

Before starting the stove, verify that the stove is properly installed and all of the requirements in this manual have been followed.



Keep all flammable materials 36" away from the front of the stove (drapes, furniture, clothing, etc.).

Curing the Paint

Follow the steps below to cure the paint (first fire):

- Open doors and windows in the room to ventilate the heater during the curing process.
- Vacate the room. The fumes from the initial heating process are non-toxic but may be unpleasant.
- Slowly bring the heater to a medium burn (400°F/204°C) for 45 minutes. Then increase the burn temperature to a hot burn (600°F/315°C) for an additional 45 minutes. This will cure the paint.

Door Gasket - The door gasket can adhere to the paint on the front of the heater. To prevent this, carefully open and close the door a few times during the paint curing process.

2 to 4 hours

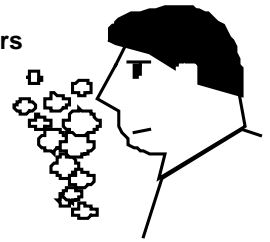
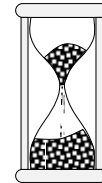

Over-Firing the Stove

DO NOT OVERFIRE THIS HEATER: Attempts to achieve heat output rates that exceed heater design specifications can result in permanent damage to the heater.

This stove was designed to operate at a high temperature. But due to differences in vent configuration, fuel, and draft, this appliance can be operated at an excessive temperature. If the stove top or other area starts to glow red, you are over-firing the stove. Shut the air control down to low and allow the stove to cool before proceeding.



Over-firing may lead to damage of plated surfaces. If any portion of the heater glows red, it is considered over-firing and will void the warranty.

Opening the Door



The door becomes hot during use. Use a glove to open the door if the handle is hot.



To prevent smoke from entering the room, open the bypass before opening the door (see following page for directions). You can also open the door a small amount and let air enter the firebox.

Opening the Doors

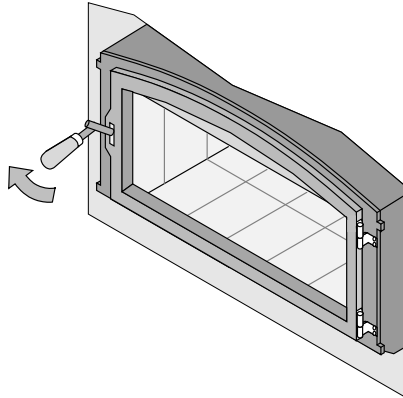

Rotate the handle up.

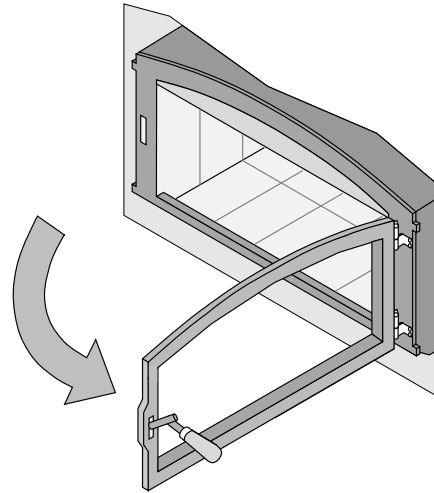

Swing the door open.

Closing the Doors

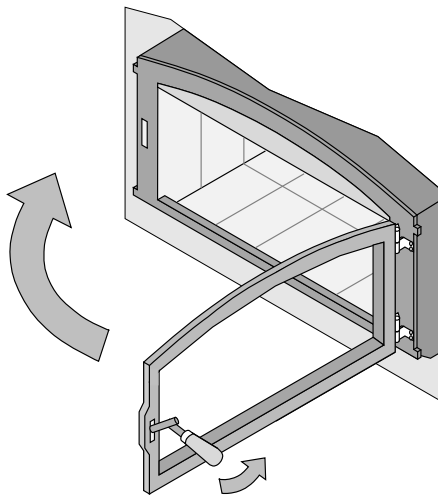

Lift the handle and close the door.

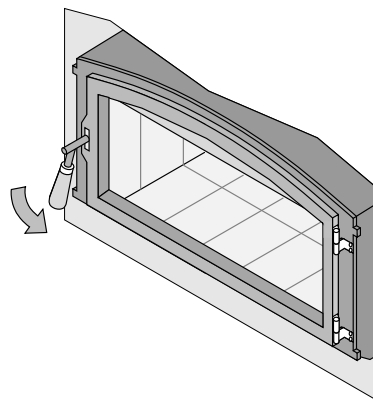

Rotate the handle down to secure the door.

Bypass Operation

The bypass controls the flow of smoke inside the heater. When pulled out, smoke goes directly up the flue, creating more draft. When pushed in, the smoke goes around the baffle, through the combustor, utilizing secondary combustion and making the heater more efficient.

- When starting or re-loading, pull the bypass out, if necessary.
- During normal operation, push the bypass in.

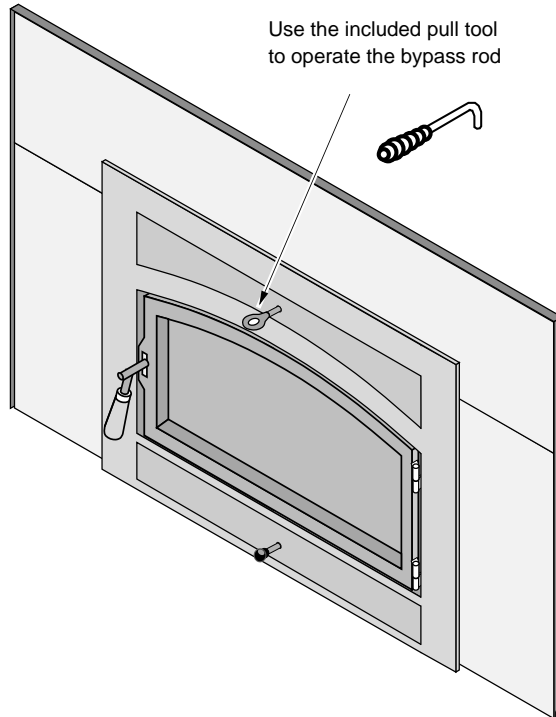

Bypass Pulled Out

Used for starting and re-loading

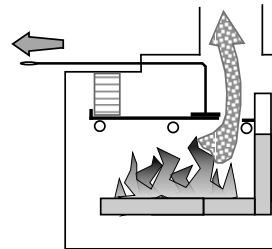

Bypass Pushed In

Used for normal operation

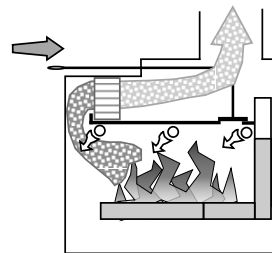

Maintaining Catalytic Burn-Off

This fireplace uses a catalytic combustor to increase heat transfer to the room and reduce emissions.

Follow the directions below to utilize the combustor to its fullest potential.

- Keep the by-pass open (pulled out) until the fireplace becomes hot (approximately 15 to 30 minutes).
- Close the by-pass (push in) when the fireplace is hot.
- Keep the by-pass closed (pushed in) while the fireplace is operating, except when re-loading.

How to Check if your Combustor is Working

A combustor temperature probe is included with the fireplace to monitor the combustor. After the bypass is engaged, the combustor temperature should rise, showing combustor operation. Combustor temperatures over 500° F (260° C), indicate the combustor is working and igniting unburnt fuel.

The combustor can also be viewed through the glass from below. You will notice the combustor glowing red when the combustor is working effectively.

The catalytic combustor takes dirty smoke and turns it into extra heat and cleaner emissions.

NOTE: If the combustor is engaged (bypass closed) when the fireplace is still cool, it will not work, leading to dirty smoke, no extra heat, and a dirtier combustor.

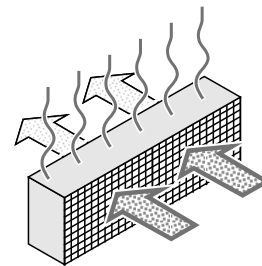

Press this ON/HOLD button to view the temperature

Catalytic Combustor – Use and Cleaning

This heater uses a catalytic combustor to improve efficiency and reduce emissions. To work at its optimum, the combustor must be kept free of excessive ash. If the heater becomes sluggish when the bypass is closed, flyash may be building up on the combustor. See the directions below to inspect and clean the combustor with the included brush.

Testing your Catalyst Combustor

A combustor that is not functioning may still show active temperatures during the medium and high burn rates with the primary fire providing enough heat to hold output temperatures above 500°f. To check the combustor function burn your fireplace for at least 2-3 hours on the medium to high setting ensuring a full coal bed covers the firebox floor and the unit is at operating temperature. Set your burn rate to medium low and monitor the catalyst output temperature. The combustor should maintain a temperature above 500°f. If your combustor temp falls below 500°f perform this test two or three times to ensure the results. If your results are the same your combustor may need cleaning or replacement. Note: If you reload your fireplace before starting your burn test burn the new fuel load on high for at least 20 min before setting your burn rate to medium low.

Inspecting & Cleaning the Combustor



The combustor becomes very hot during operation. Let the heater cool before cleaning the combustor.

The combustor is located directly above the firebox opening. Make sure the square openings are open for air to pass through. If ash is accumulating, use the brush to clear off visible flyash.

NOTE: To thoroughly clean the combustor, use an ash vacuum to pull flyash from the combustor (see page 33).



Starting a Fire

Since the dawn of time man has debated the best way to start a fire. Some use the boy-scout "tee-pee"; some prefer the "tic-tac-toe" stack. Either way, review the hints and warnings below to ensure proper fire starting.

- Make sure the air control is pushed in and the by-pass pulled out. If additional air is needed, open the door 1/4" during the first five minutes of start-up.

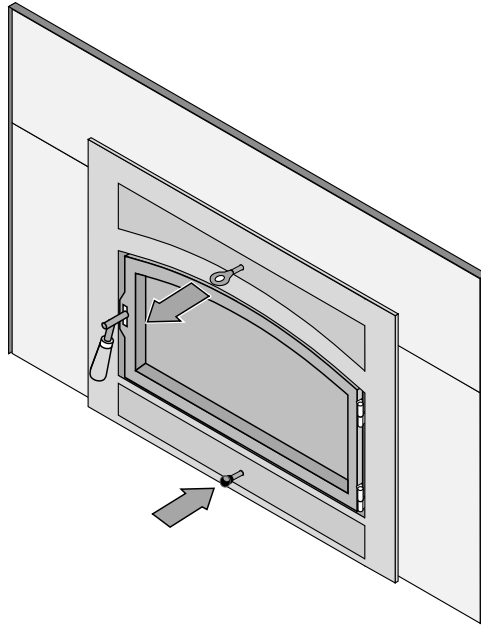

Never use gasoline, gasoline-type lantern fuel, kerosene, charcoal lighter fluid, or similar liquids to start or "freshen up" a fire in this stove. Keep all such liquids well away from the stove while it is in use.



DO NOT USE CHEMICALS OR FLUIDS TO START THE FIRE. DO NOT BURN GARBAGE OR FLAMMABLE FLUIDS SUCH AS GASOLINE, NAPHTHA OR ENGINE OIL. Do not place such fuel within space heater installation clearances or within the space required for charging and ash removal.



If using a fire-starter, use only products specifically designed for stoves - follow the manufacturer's instructions carefully.



HOT WHILE IN OPERATION. KEEP CHILDREN, CLOTHING AND FURNITURE AWAY. CONTACT MAY CAUSE SKIN BURNS.



If the smoke does not pass up the chimney, ball up one sheet of newspaper, place it in the center of the firebox and light it. This should start the chimney drafting (this eliminates "cold air blockage").



Use plenty of kindling to ensure the stove reaches a proper temperature. Once the kindling is burning rapidly, place a few larger pieces of wood onto the fire.

Starting a "Top-Down Fire"

One particularly successful method for starting a fire is to stack several large pieces of wood in the center of the stove (see the illustration to the right). Then place a several wads of newspaper in the center with kindling on top. When you light the newspaper this "top-down" fire will burn its way to the center, igniting the larger pieces. With some practice, this method should work for you.

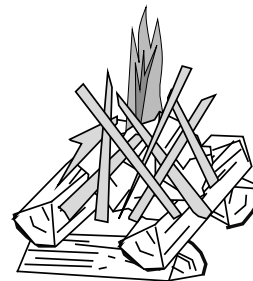

Adjusting the Burn Rate

Use the air control slider to control the burn rate of the stove. See the illustration below for details.

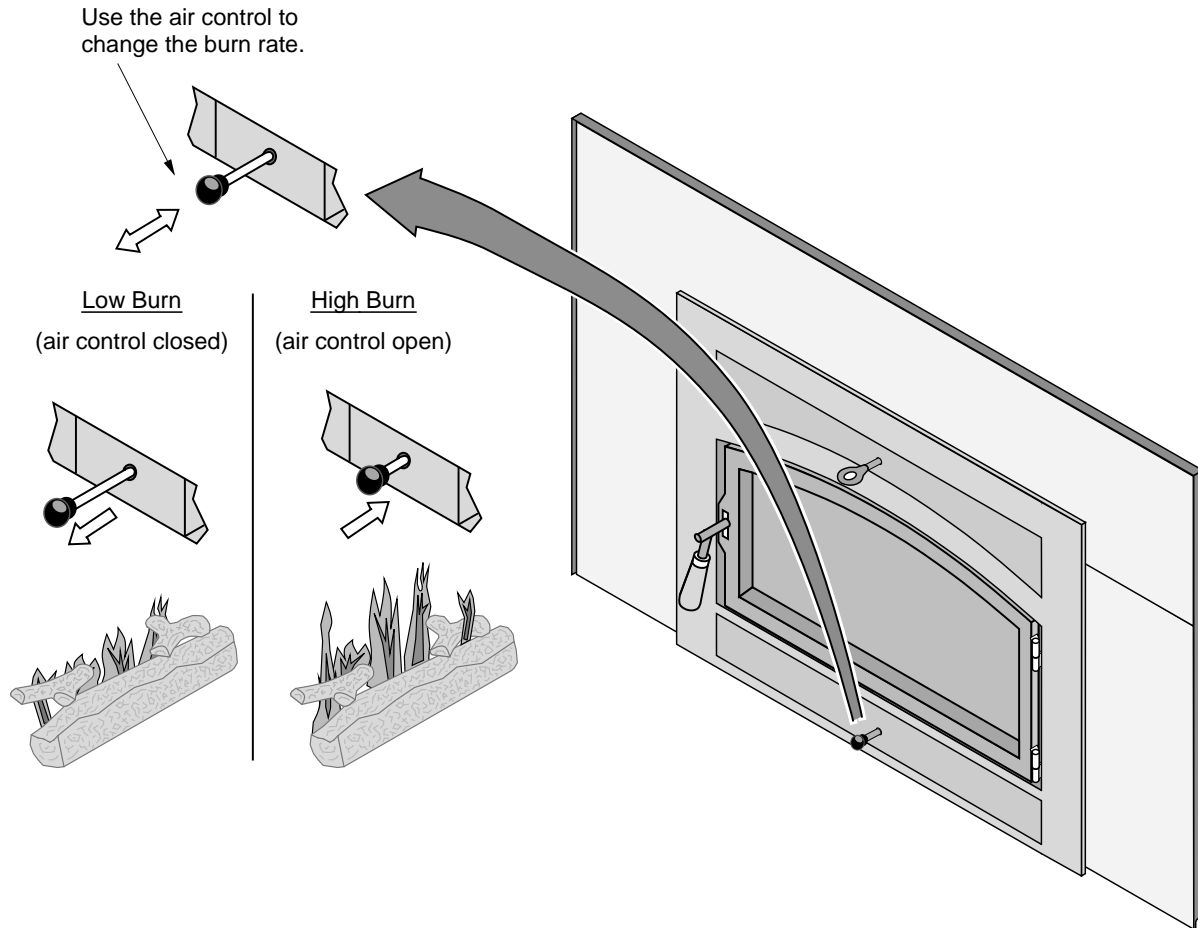

Approximate Air Control Settings:

Overnight Burn	Pulled fully out
Medium Burn	Pulled fully out to 5/8" in
Medium High Burn	5/8" to all the way in
High Burn	Pushed all the way in



The air control becomes hot during operation - use gloves or a tool to prevent burns.



The air control may take several minutes to influence the burn rate. When making adjustments, you may wish to let the stove burn for 10 minutes to gauge performance.

Understanding Your Heater's Combustion System

This heater uses a dual combustion system detailed below:

Primary Combustion: This is the combustion (fire) that takes place directly on the wood. Primary combustion determines how fast the fire burns. Air for primary combustion is supplied through the air control. When you adjust the air control you control the amount of air that reaches the fire and creates primary combustion. The air control supplies air to the air wash (the air holes above the door opening – used to help clean the glass) and through the pilot orifice (center bottom of the door opening). By using the air control, and supplying air through these two openings, you control primary combustion.

Secondary & Catalytic Combustion: This is the combustion (fire) that does not contact the wood. Secondary combustion burns the visible emissions or smoke that is not consumed during primary combustion. It takes place at the top of the firebox and can appear as a glowing flame near the secondary air tubes. Catalytic combustion takes place inside the catalytic combustor and is not viewable (you may, however, see the combustor glow). It also burns the visible emissions or smoke that is not consumed during primary combustion. Catalytic combustion can be monitored by using the included temperature meter. Your catalytic combustor is working when the output temperature is above 500° F. (260°C).

Items to Consider:

- During medium and high burn rates the stove will manage secondary and primary combustion on its own. When the heater is set to a low burn rate more care is needed to ensure the secondary combustion system works properly. Make sure the stove is hot and a good coal bed is established before adjusting your heater to low burn.
- Understanding the combustion system in this heater will help minimize the visible emissions this heater releases into the environment. The primary pilot orifice at the center bottom of the door opening is designed to help the secondary combustion at low burn settings. The pilot provides a small amount of air that burns up through the fuel load providing the heat and flame needed for the secondary system to ignite. The air tubes under the baffle need to remain ignited for low burns to be effective.
- As you load your heater for a low burn, take care in placing the wood. This will affect how well your secondary system works as the wood is consumed. Do not block the pilot orifice. Stack wood so the pilot air can burn its way up between the pieces, helping your heater burn effectively throughout the low fire. This will reduce the visible emissions your heater produces and increase the amount of heat you get from the wood. If you are unsure how well your heater is burning look at the chimney cap to monitor visible emissions.

Burning Your Heater

Starting a Fire: When starting a fire it is imperative to get the heater hot and drafting as quickly as possible. This promotes combustion and reduces emissions. There are many ways to start a fire and you will become adept as you become familiar with the way your heater burns. Before you start, make sure your burn rate setting (air control) is all the way open and the by-pass (if equipped) is open. We suggest that you use a layer of crumpled newspaper covered with a three layers of small kindling, stacked tic tac toe style with approximately ½"-1" gaps between them. Continue to layer wood on top of the kindling with the same air gaps using slightly bigger pieces increasing in size as you stack upward with the final layer being 3-5" diameter pieces loaded on the top. This should fill the firebox. Light the newspaper in several places near the door opening. Shut the door but do not latch it, creating a small opening to allow air to feed the kindling fire. Never leave your heater unattended if your door is not latched shut. While the kindling burns the fire will heat and ignite the larger pieces above. Once the whole load is burning shut and latch the door leaving the burn rate on high. Depending on your heater, the chimney, and the outside environment, you may need to leave your bypass open for up to 20 minutes after lighting the fire. If the fire dies when you shut the bypass you will need to leave it open longer. The presence of a hot coalbed is critical to good combustion. We cannot overstate the importance of a hot coal bed before slowing your burn rate or re-loading your heater. We recommend that you allow the first ignition load of wood to burn through at the high burn rate. This will get your heater up to temperature and establish a coal bed.

Reloading: When reloading a hot heater set the burn rate on high for at least 15 min before slowing it down.

Low Burn: If preparing for an overnight or low burn a longer heat up period may be necessary. Reload the heater full of wood making sure there are air gaps between the wood pieces so the pilot air can burn up through the middle load keeping the secondary combustion system hot and active throughout the burn. After loading, burn the heater on high for at least 15 minutes before setting the air control to low. Excessive creosote buildup (or sooting) in the heater at the end of a low burn signifies that the heater was not hot enough and the wood load was not burned long enough on high after loading before shutting down the air control.

Blower Operation

The blower will turn on once the stove is up to temperature. This is typically 15 to 30 minutes after starting the fire. Follow the directions below to alter the blower speed.



The blower rheostat dial may look different. It does operate in the same fashion.

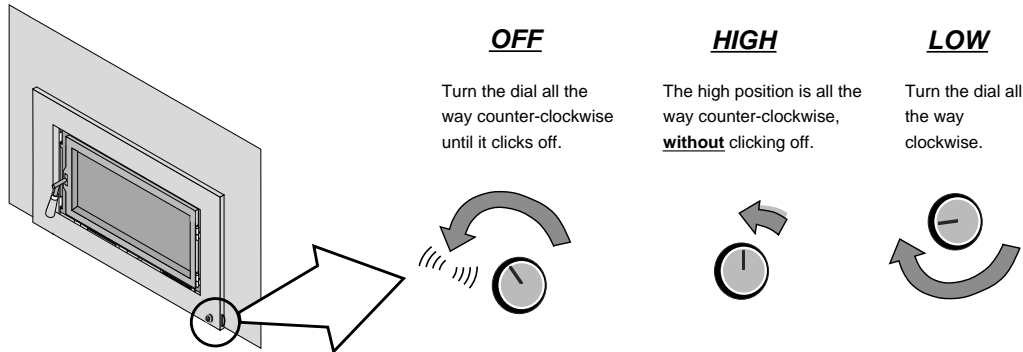

The blower may be used to affect heat output (i.e.: to reduce heat output, turn the blower down).



Route the power cord in a location where it will not come in contact with the appliance or become hot.

Re-Loading the Stove

Follow the directions below to minimize smoke spillage while re-loading the stove.

- 1 Open the air control all the way (push it in). Open the bypass (if necessary).
- 2 Open the door slightly. Let airflow inside the firebox stabilize before opening the doors fully.
- 3 Load wood onto the fire.

Overnight Burn

Follow the steps below to achieve an overnight burn.

- 1 Move the air control to high burn and let the stove become hot (burn for approximately 15 minutes).
- 2 Load as much wood as possible. Use large pieces if possible.
- 3 Let the stove burn on high for 15 minutes to keep the stove hot, and then turn the air control to low.
- 4 In the morning the stove should still be hot, with embers in the coal bed. Stir the coals and load small pieces of wood to re-ignite the fire, if desired.



Differences in chimney height and draft may lower overall burn times.

Normal Operating Sounds

Creaks and Clicks:

The steel may creak or click when the stove heats up and cools down - this is normal.

Blower Sounds:

The blower will make a slight "hum" as it pushes air through the stove.

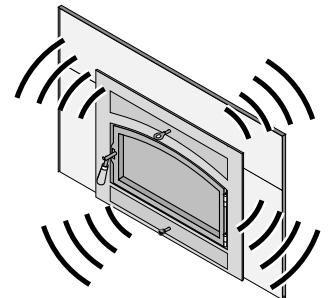

Hints for Burning

- Get the appliance hot before adjusting to low burn
- Use smaller pieces of wood during start-up and high burns to increase temperature
- Use larger pieces of wood for overnight or sustained burns
- Stack the wood tightly together to establish a longer burn
- Be considerate of neighbors & the environment: burn dry wood only
- Burn small, intense fires instead of large, slow burning fires when possible
- Learn your appliance's operating characteristics to obtain optimum performance

Selecting Wood

- Dry Wood is Key – moisture content should be less than 20%
- Dry wood burns hot, emits less smoke and creates less creosote.
- Testing Wood Moisture
- Split wood stored in a dry area will be fully dry within a year. This insures dry wood. If purchasing wood for immediate use, test the wood with a moisture meter. Some experienced wood burners can measure wood moisture by knocking pieces together and listening for a clear "knock" and not a "thud".

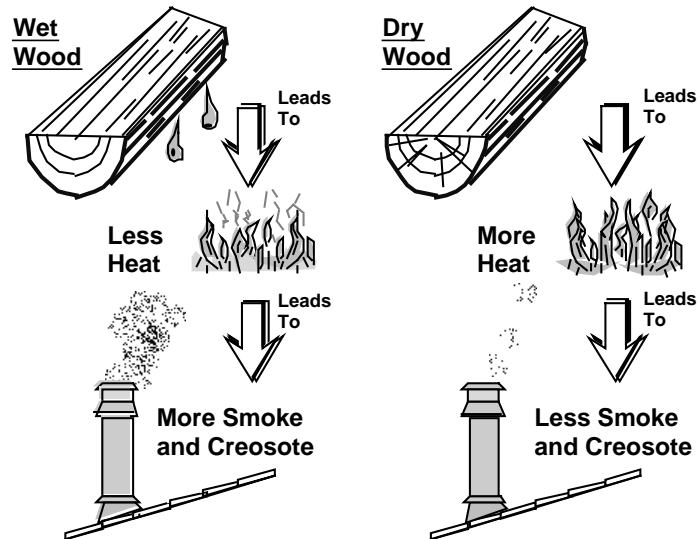

Why Dry Wood is Key

Wet wood, when burned, must release water stored within the wood. This cools the fire, creates creosote, and hampers a complete burn. Ask any experienced wood burner and he or she will agree: dry wood is crucial to good performance.

Wood Cutting and Storage

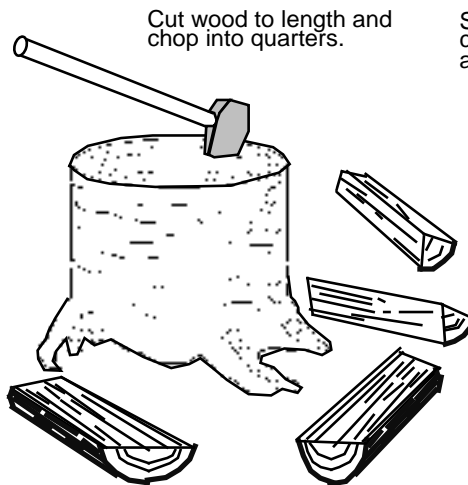

Store the wood off the ground in a covered area. Allow for airflow around the wood to dry the wood.

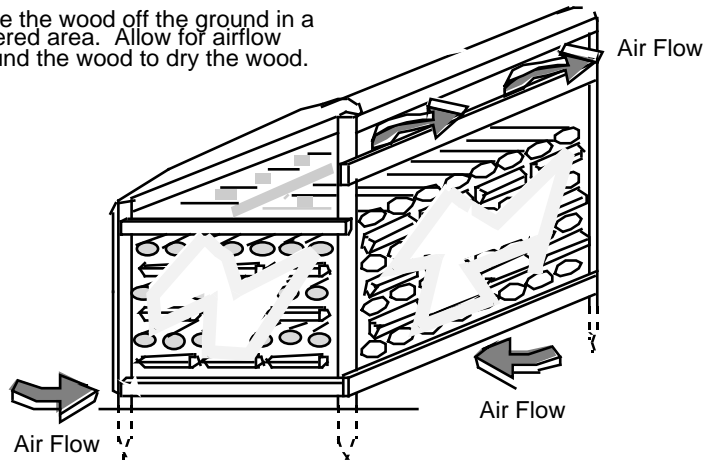

Do Not Burn List

This heater is designed to burn natural wood only. Higher efficiencies and lower emissions generally result when burning air dried seasoned hardwoods, as compared to softwoods or to green or freshly cut hardwoods. **DO NOT BURN:**

- (1) Garbage;
- (2) Lawn clippings or yard waste;
- (3) Materials containing rubber, including tires;
- (4) Materials containing plastic;
- (5) Waste petroleum products, paints or paint thinners, or asphalt products;
- (6) Materials containing asbestos;
- (7) Construction or demolition debris;
- (8) Railroad ties or pressure-treated wood;
- (9) Manure or animal remains;
- (10) Salt water driftwood or other previously salt water saturated materials;
- (11) Unseasoned wood; or
- (12) Paper products, cardboard, plywood, or particleboard. The prohibition against burning these materials does not prohibit the use of fire starters made from paper, cardboard, saw dust, wax and similar substances for the purpose of starting a fire in an affected wood heater.

Burning these materials may result in release of toxic fumes or render the heater ineffective and cause smoke.

Troubleshooting

Problem	Possible Cause
Smoke Enters Room During Start-Up	<ul style="list-style-type: none"> • Open the bypass (pg. 22). • Open the air control (pg. 25). • Cold Air Blockage - burn a piece of newspaper to establish a draft. • If the flame is not getting enough air, a small crack in the door is all that is needed.
Kindling Does Not Start - Fire Smolders	<ul style="list-style-type: none"> • Open the bypass (pg. 22). • Open the air control (pg. 25). • Not enough starter paper - use additional newspaper if necessary. • If the flame is not getting enough air, a small crack in the door is all that is needed.
Smoke Enters Room While Re-Loading	<ul style="list-style-type: none"> • Open the bypass before opening the door (pg. 22). • Open the air control before opening the door (pg. 25). • Let the air stabilize before fully opening the door. Then open the door approximately 1 inch. Let air go into the firebox for a few seconds. Once the smoke appears to be flowing up the chimney consistently, open the door. • Insufficient Draft - Chimney height and outside conditions can negatively affect draft. In these cases a small amount of smoke may enter the home. Adding more piping or a draft-inducing cap may help. • Chimney liner joints are not properly sealed at the insert connection.
Stove Does Not Burn Hot Enough	<ul style="list-style-type: none"> • Wood is Wet - see the section "Selecting Wood" on page 28 for details on wood. • Make sure the air control is all the way open. Slide the control back and forth to insure the control is not stuck. • Insufficient Draft - Chimney height and outside conditions can negatively affect draft. In these cases the fire may burn slowly. Adding more piping or a draft-inducing cap may help.
Blower Does Not Run	<ul style="list-style-type: none"> • Stove is Not Up to Temperature - This is normal. The blower will come on when the stove is hot - usually 15 to 30 minutes. • Electricity Is Cut to the Blower - Check the household breaker or fuse to make sure it is operable.
Stove Does Not Burn Long Enough	<ul style="list-style-type: none"> • Depending upon wood, draft, and other factors, the burn time may be shorter than stated. Make sure the doors are sealing and not allowing air into the firebox - See the section "Door and Glass Inspection" on page 32 for details. • Check the ash bed for coals. Often, coals are still glowing under a slight bed of flyash. By raking these into a pile you can re-start your stove quickly.



Must replace components with equipment equivalent to the original or approved by the manufacturer.



Failure to properly maintain and inspect your appliance may reduce the performance and life of the appliance, void your warranty, and create a fire hazard.



Establish a routine for the fuel, wood burner and firing technique. Check daily for creosote build-up until experience shows how often you need to clean to be safe. Be aware that the hotter the fire the less creosote is deposited, and weekly cleaning may be necessary in mild weather even though monthly cleaning may be enough in the coldest months. Contact your local municipal or provincial fire authority for information on how to handle a chimney fire. Have a clearly understood plan to handle a chimney fire.

Daily Maintenance (while stove is in use)

Remove Ash (if necessary)

Whenever ashes get 3 to 4 inches deep in your firebox or ash pan, and when the fire has burned down and cooled, remove excess ashes. Leave an ash bed approximately 1 inch deep on the firebox bottom to help maintain a hot charcoal bed. Let the stove cool completely before removing ashes (wait at least two hours after the last coal has extinguished). Ashes should be placed in a metal container with a tight-fitting lid. The closed container of ashes should be placed on a noncombustible floor or on the ground, away from all combustible materials, pending final disposal. The ashes should be retained in the closed container until all cinders have thoroughly cooled.

- Follow the directions below to remove ash.
 - 1 Let the stove cool completely (at least two hours after the last coal has extinguished).
 - 2 Place a cloth or cardboard protector over the hearth to catch ash and protect against scratching.
 - 3 Open the doors and scoop the ash into a metal container with a tight fitting lid. The closed container of ashes should be placed on a noncombustible floor or on the ground, away from all combustible materials, pending final disposal.



Improperly disposed ashes lead to fires. Hot ashes placed in cardboard boxes, dumped in back yards, or stored in garages, are recipes for disaster.



Wood-burning stoves are inherently dirty. During cleaning have a vacuum ready to catch spilled ash (make sure ash is entirely extinguished).



There are vacuum cleaners specifically made to remove ash (even if the ash is warm). Contact your dealer for details.

Clean the Glass (if necessary)

This appliance has an airwash to keep the glass clean. However, burning un-seasoned wood or burning on lower burn rates leads to dirtier glass (especially on the sides). Do not clean glass with abrasive cleaners. Allow the stove to fully cool before cleaning.

Apply glass cleaner or soapy water to the inside of the glass. Wipe with newspaper or a paper towel to clean. For stubborn creosote, dip a moist paper towel or newspaper in cold ash before cleaning. The ash acts as a mild abrasive.

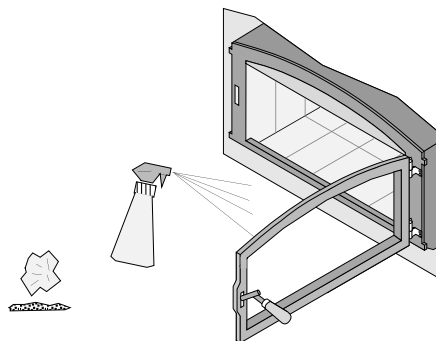

The glass will develop a very slight haze over time. This is normal and will not affect viewing of the fire.

Monthly Maintenance (while appliance is in use)



Make sure the appliance has fully cooled prior to conducting service.

Door and Glass Inspection



The door can be lifted off the hinges if extensive repairs are needed.

The door must form a seal to the firebox for the stove to work correctly. Inspect the door gasket as shown below.

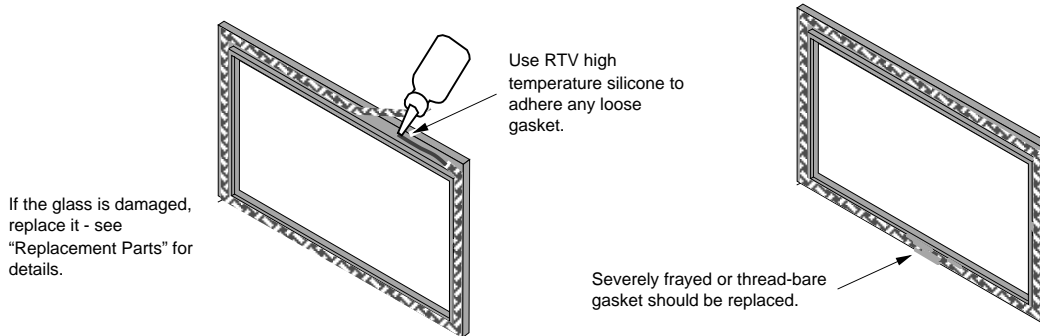

Door Latch Adjustment

The door latch should pull the door against the face of the stove (but not so tight as to not allow full handle rotation). If the latch requires adjustment, follow the directions below.

Remove the face. Loosen the bottom nut with a 7/16" wrench (see arrow to the right). Tap the bottom nut inwards, moving the door catch inwards. Tighten the nut and test operation. You may need to repeat this process, either moving the nut inwards or outwards, until the door catch is in the correct position.

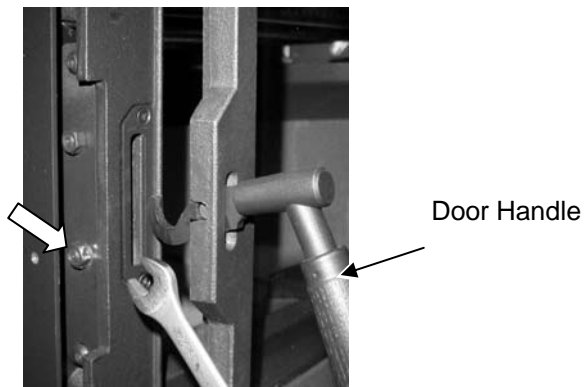

Creosote - Formation and Need for Removal

When wood is burned slowly, it produces tar and other organic vapors, which combine with expelled moisture to form creosote. The creosote vapors condense in the relatively cool chimney flue of a slow-burning fire. As a result, creosote residue accumulates on the flue lining. When ignited, this creosote makes an extremely hot fire. The chimney and chimney connector should be inspected at least once every two months during the heating season to determine if a creosote buildup has occurred. If creosote has accumulated 1/8" (3mm), it should be removed to reduce the risk of a chimney fire.



If you are not certain of creosote inspection, contact your dealer or local chimney sweep for a full inspection. Excess creosote buildup may cause a chimney fire that may result in property damage, injury, or death.



Operating this appliance continually at a low burn rate (air starvation) or using green (un-seasoned) wood will increase the formation of creosote.

Cleaning the Catalytic Combustor

NOTE: We strongly recommend using an ash vacuum with brush attachment to clean the catalytic combustor. If you do not have one, you may use a brush to dislodge flyash.

1. With the stove fully cooled, insert the ash vacuum nozzle into the area directly above the door opening.



2. Carefully place the brush surface of the nozzle over the catalytic combustor openings and remove any ash or debris. Take care to prevent damage to the catalytic combustor (the surface is fragile).



Yearly Maintenance



Make sure the appliance has fully cooled prior to conducting service.

Touch-Up Paint

Included with the owner's pack of this appliance is a can of Stove-Brite® paint. To touch up nicks or dulled paint, apply the paint while the appliance is cool. Sand rusted or damaged areas before preparation (use 120-grit sandpaper). Clean and dry the area to prepare the surface. Wait at least one hour before starting the appliance. The touched up area will appear darker than the surrounding paint until it cures from heat. Curing will give off some fumes while curing – open windows to ventilate.

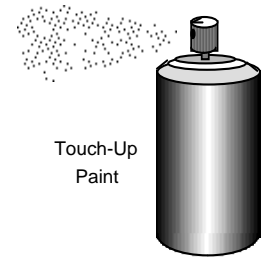

Cleaning the Air Duct and Blower (if applicable)

Use a vacuum to clean the air ducts (channels). This prevents dust from burning and creating odors. The blower should be vacuumed every year to remove any buildup of dust, lint, etc.

Remove the face. Use a vacuum cleaner to remove any debris or dust in the convection chamber or near the blower (WARNING: do not touch the blower blades).

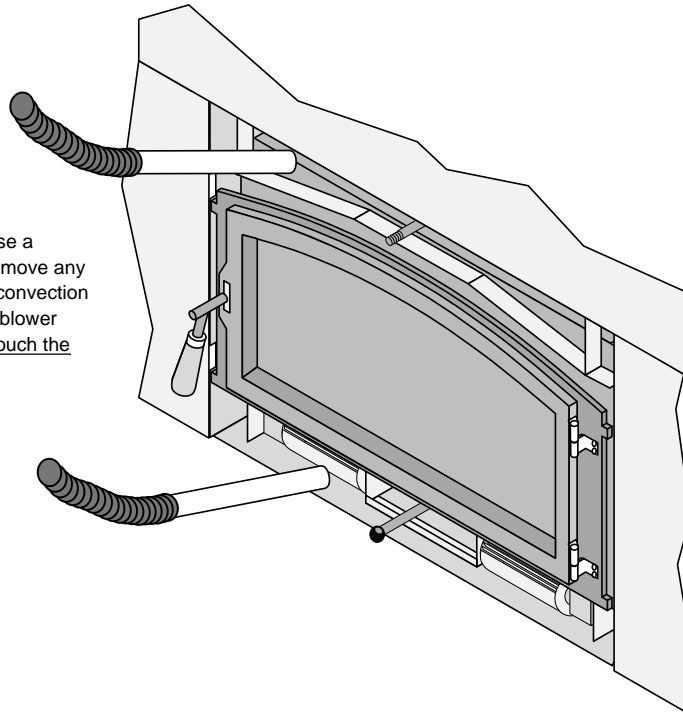

Firebrick and Baffle Inspection

Use the illustration on page 35 as a reference for checking the following items. Make sure the appliance is cool before proceeding.

Baffle - check the baffle plate along the ceiling of the firebox to make sure it is intact. Check the bypass assembly.

Secondary Air Tubes - Check the air tubes to make sure they are intact and not severely deteriorated. Slight scaling or rusting of the metal is normal. Make sure the air tubes are secured correctly.

Floor and Wall Firebricks - replace any severely damaged firebrick along the side or floor of the firebox.

Door Parts

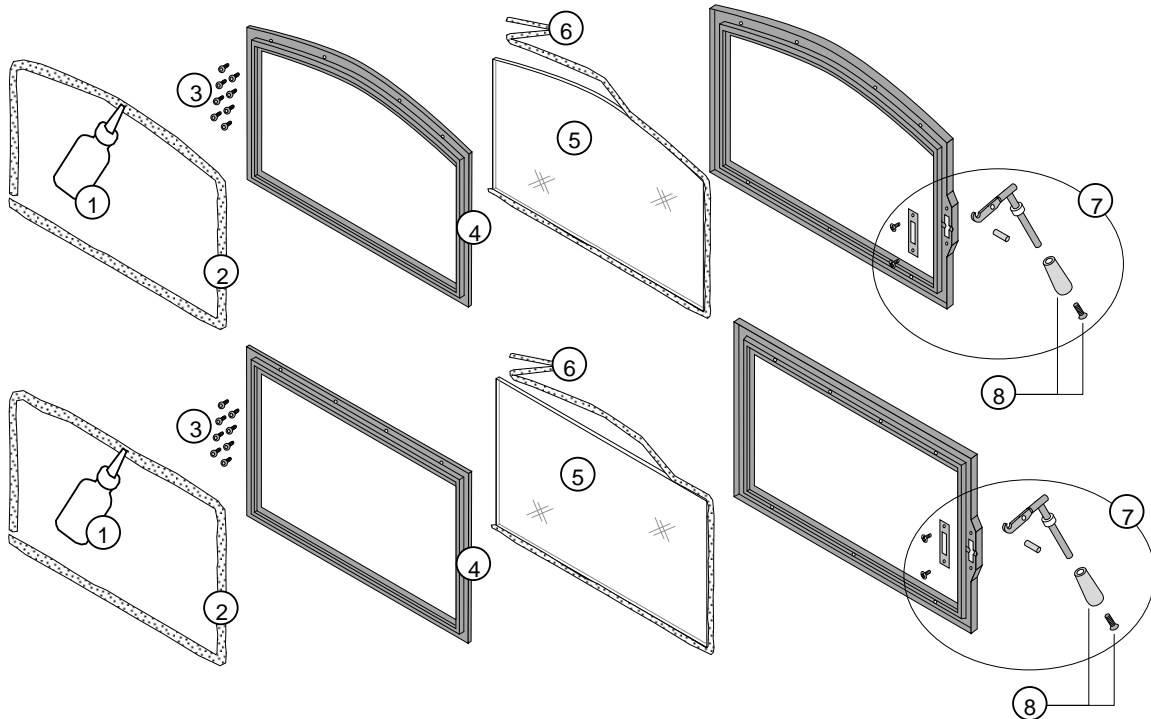

ID #	Description	Qty.	Part #	ID #	Description	Qty.	Part #
1	Gasket Cement, 4 oz.	1	99900427	2	Door Gasket	1	250-02832
3	Glass Retainer Screws	1	250-02967	4	Glass Retainer – Arched Glass Retainer – Rectangular	1	250-02968 250-03052
5	Glass – Arched Glass – Rectangular	1	250-02969 250-03051	6	Glass Gasket	1	250-02970
7	Handle Assembly	1	250-02971	8	Wood Handle w Screw	1	250-01305

Replacing the Glass



The glass must not contact the door retainer or glass clips directly. The glass gasket and glass clip gaskets insulate the glass to prevent cracking. Do not over-tighten the glass clips. Use only 5mm thick neo-ceramic glass.

Lay the glass gasket in the door frame (cut off excess gasket). Place the glass on the gasket. Secure the glass clips to hold the glass in place (make sure the glass clip gaskets are in place).

Replacing the Door Gasket

The door gasket inserts into the outer groove of the door retainer. Stove gasket cement holds it in place. Before installing, remove any residual cement. Lay the gasket in place (start at the lower left corner) and cut off any excess gasket (do not stretch the gasket. The cement fully cures with heat from the stove. You may need to open and close the door repeatedly to get the gasket to seat fully.

Blower and Electrical Parts

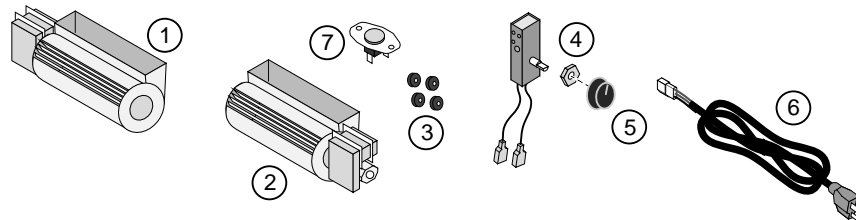

ID #	Description	Qty.	Part #	ID #	Description	Qty.	Part #
1	Left Blower	1	228-10069	2	Right Blower	1	228-10070
3	(4) Blower Grommets w Spacers	1	93005017	4	Rheostat w Nut	1	250-00302
5	Rheostat Knob	1	250-00369	6	Power Cord	1	250-00316
7	Thermodisk	1	228-30050				

Firebox Parts

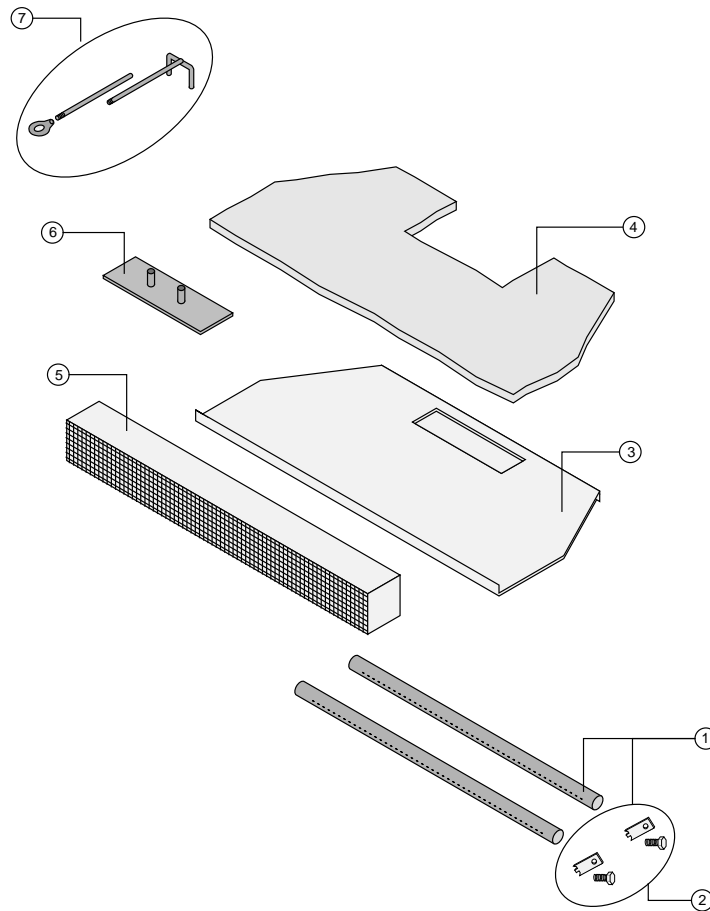

Baffle Parts

ID #	Description	Qty.	Part #	ID #	Description	Qty.	Part #
1	Sec. Air Tubes w Pins (2)	1	98900246	2	Air Tube Pin (w Screw)		250-02186
3	Baffle	1	250-02973	4	Baffle Insulation	1	250-02974
5	Catalytic Combustor with Gasket	1	250-02489	6	Bypass Slider	1	250-02975
7	Damper Yoke Assembly	1	250-02976	7b	Damper Extension Rod	1	250-02977

Baffle Removal

- 1 Remove the face to prevent damage. Remove the door (lift off hinges).
- 2 Remove the front two air tubes (see "Air Tube Removal & Replacement" on the following page).
- 3 Remove the baffle plate and insulation.

Combustor

Your combustor is available through an authorized Travis dealer. You can visually check the condition of your combustor by opening the door and looking above the baffle with a flashlight. If there is visible ash accumulation on the surface of your combustor it should be cleaned off with a soft bristled brush. If there is visible creosote buildup (tar substance) on the combustor, burn your stove on high and the creosote should burn off. If the creosote does not burn off your catalyst needs to be replaced. If the insert emits excessive smoke on medium and high burns your catalyst may need replacement.

To remove the combustor first remove the baffle (see Baffle Removal), open the bypass and reach through the bypass hole and push out the combustor from the rear. The combustor is housed in a stainless steel frame; push on the left and right side edges of the combustor frame so that it slides out evenly. If the combustor is pushed at a side angle it will not come out.

Air Tube Removal & Replacement



Use penetrating oil (WD-40™ or similar) on the bolts before removing them. Let the oil soak in for several minutes before attempting to remove the bolts.

Front Air Tube = 21.2" (539mm)

Rear Air Tube = 19.5" (496mm)

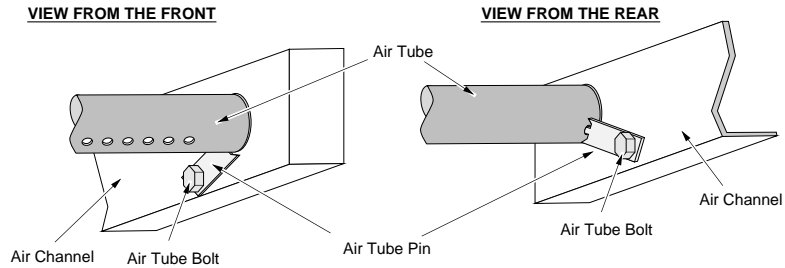

AIR TUBE REMOVAL

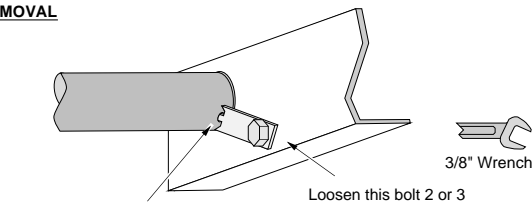

Note how the center of the air tube pin inserts into a hole on the air tube.

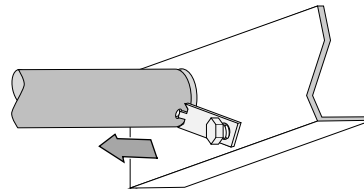

With the bolt loosened the air tube can be slid out of the air channel.

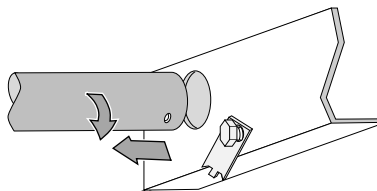

The pin will then disengage from the air tube (you may wish to rotate the tube slightly).

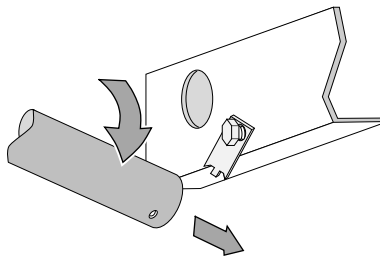

Pivot the air tube downwards and slide it out of the air channel on the opposite side.

Brick Removal & Replacement

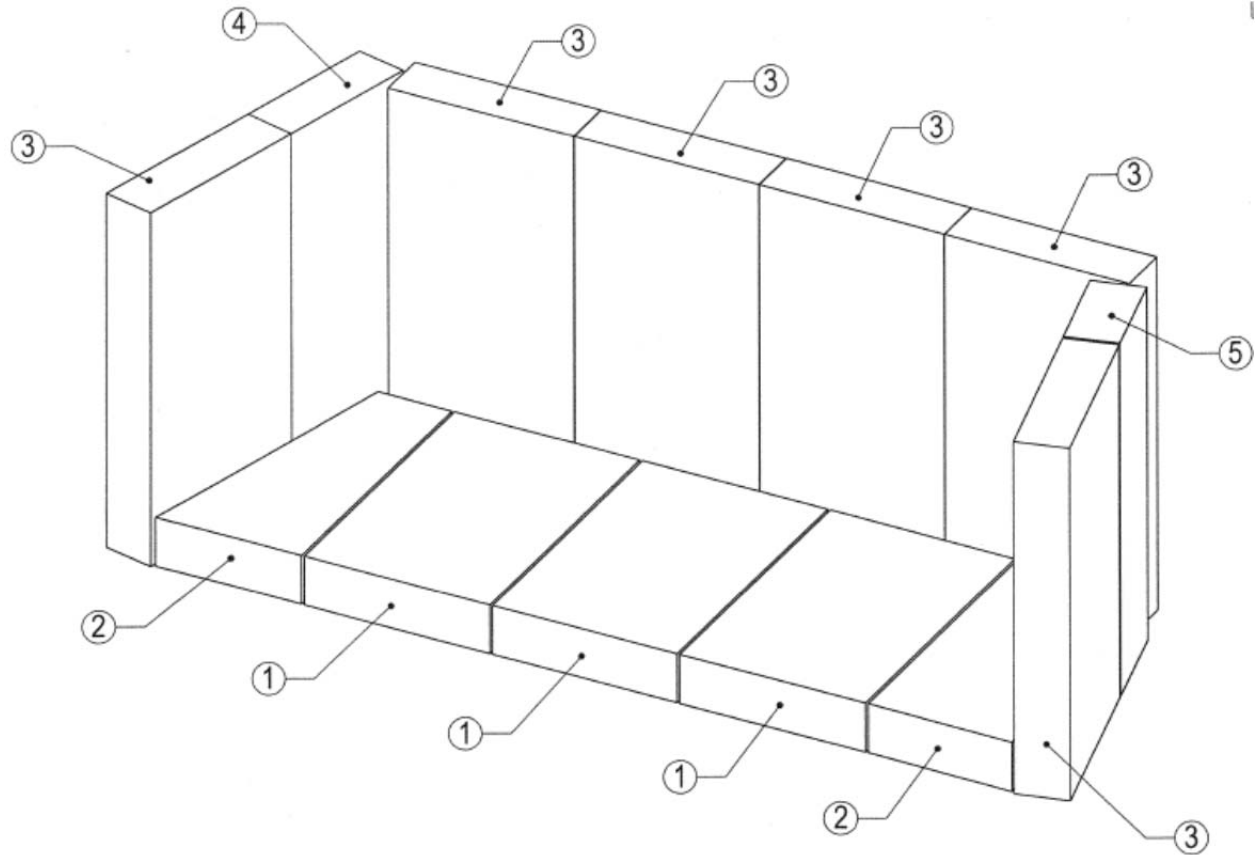

NOTE: "F" Denotes Full Size Brick (4-1/2" x 9")

ID #	Description	Qty.	Part #	ID #	Description	Qty.	Part #
1	Cut Brick, 6.9" x 4.5"	3	251-00074	2	Cut Brick, 6.9" x 1.7" x 3.5"	2	251-00075
3	Brick, Full (4.5" x 9")	6	251-00000	4	Cut Brick, 9x 3.6"	1	251-00049
5	Cut Brick, 9" x 2.4"	1	251-00076		Igniter Brick (not pictured)	1	251-00077



Do not pry the brick - they chip and crack easily.

Remove the floor bricks first. The side bricks are pinned in place by the floor firebrick. Clean the firebox prior to replacing the brick.

GreenStart™ Igniter – Firebrick and Housing Installation

Minimum Fireplace Size

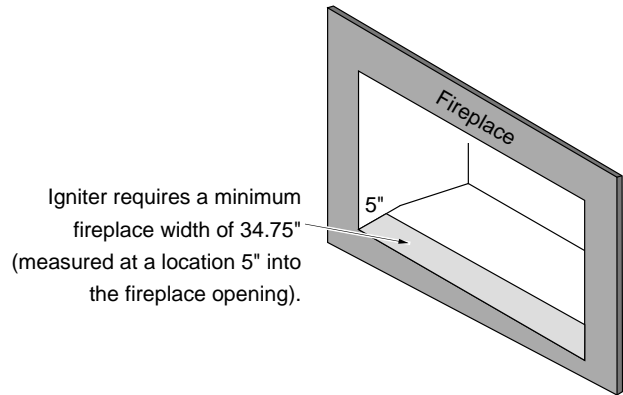

Igniter Firebrick and Housing

This insert is compatible with the GreenStart™ automatic wood-stove igniter. This optional component uses a specialized firebrick and housing that are shipped with the insert. If you are using the igniter, install these components as shown below. The igniter is installed as shown in the instructions included with the igniter kit.



Igniter Firebrick



Igniter Housing

HINT: If you are not using the igniter, store these components inside the fireplace cavity in case the homeowner later decides to install them.

1. Remove the two firebricks from the front left corner of the firebox.



2. Place the igniter firebrick as shown below.

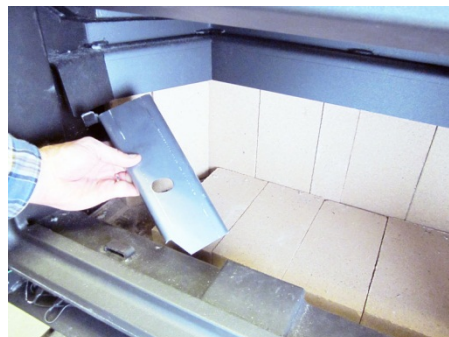

3. Replace the floor firebrick to complete the installation.

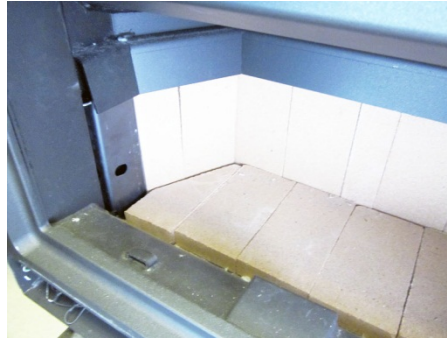

4. Remove the cover and gasket using a 5/16" nutdriver. See the photos below.

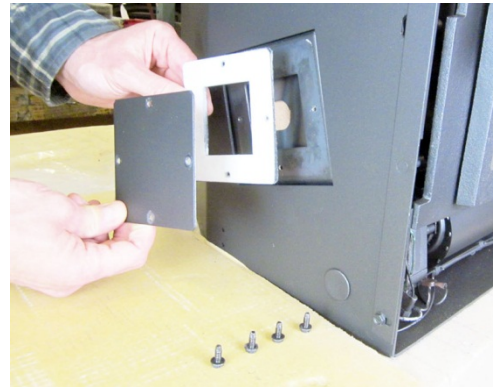

5. Install the housing as shown below.
NOTE: The gasket's hole patterns are unique. The housing must be re-installed in the same configuration. If the holes are not aligned, rotate the gasket 90°.

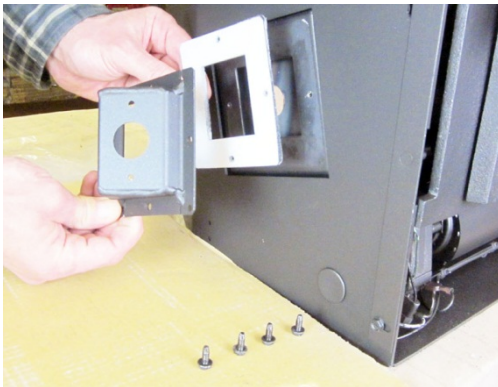

Register your TRAVIS INDUSTRIES, INC. Limited 7 Year Warranty online at traviswarranty.com. TRAVIS INDUSTRIES, INC. warrants this gas appliance (appliance is defined as the equipment manufactured by Travis Industries, Inc.) to be defect-free in material and workmanship to the original purchaser from the date of purchase as follows:

Check with your dealer in advance for any costs to you when arranging a warranty call. Mileage or service charges are not covered by this warranty. This charge can vary from store to store.

Years 1 & 2 - COVERAGE: PARTS & LABOR

- Firebox Assembly:
Firebox, Baffle Supports, Air Tubes, Air Channels, Convection Chamber
- Door Assembly:
Cast Door, Latch Assembly, Glass Retainers
- Air Control Assembly
Slider Plate, Pressure Plate
- Ceramic Glass
Glass (breakage from thermal shock)
- Catalytic Combustor
Catalytic Combustor (see "Conditions and Exclusions" # 10)
- Firebrick
Breakage from thermal shock
- Accessories
Legs, Pedestal, Blower
- Re-Installation Allowance
In cases where heater must be removed from home for repairs, a partial cost of re-installation is covered (pre-authorization required)
- One-Way Freight Allowance
One-way freight allowance on pre-authorized repair done at factory is covered.

Exclusions: Paint, Gasketing

Years 3 THROUGH 5 - COVERAGE: PARTS & LABOR

- Firebox Assembly:
Firebox, Baffle Supports, Air Tubes, Air Channels, Convection Chamber
- Air Control Assembly
Slider Plate, Pressure Plate
- Catalytic Combustor
Coverage for thermal crumbling and disintegration only
- Door Assembly:
Cast Door, Latch Assembly, Glass Retainers
- One-Way Freight Allowance
One-way freight allowance on pre-authorized repair done at factory is covered.

Exclusions: Paint, Gasketing, Accessories (Legs, Pedestal, Panels, Blower), Glass, Firebrick, Re-Installation Allowance

Years 6 THROUGH 7 - COVERAGE: PARTS

- Firebox Assembly:
Firebox, Baffle Supports, Air Tubes, Air Channels, Convection Chamber
- Air Control Assembly
Slider Plate, Pressure Plate
- Door Assembly:
Cast Door, Latch Assembly, Glass Retainers

Exclusions: Paint, Gasketing, Accessories (Legs, Pedestal, Panels, Blower), Glass, Firebrick, Re-Installation Allowance, Catalytic Combustor, One-Way Freight Allowance, Labor Charges

CONDITIONS & EXCLUSIONS

1. This new appliance must be installed by a qualified installer. It must be installed, operated, and maintained at all times in accordance with the instructions in the Owner's Manual. Any alteration, willful abuse, accident, neglect, or misuse of the product shall nullify this warranty.
2. This warranty is nontransferable, and is made to the ORIGINAL purchaser, provided that the purchase was made through an authorized Travis dealer.
3. Discoloration and some minor expansion, contraction, or movement of certain parts and resulting noise, is normal and not a defect and, therefore, not covered under warranty.
4. This warranty does not cover misuse of the stove. Misuse includes over-firing (operation where the connector or stove may glow red) of this appliance can cause serious damage and will nullify this warranty. Misuse includes use of salt saturated wood, chemically treated wood, or any fuel not recommended in the manual.
5. Damage to the stove due to improper break-in procedures (see manual for proper break in).
6. The salt air environment of coastal areas or a high humidity environment can be corrosive to the castings. These conditions can be corrosive and can cause the cast iron to rust. This warranty does not cover any damage caused by a salt air or high humidity environment.
7. Damage to the appliance while it is in transit is not covered by this warranty, but is subject to a claim against the common carrier.
8. The warranty, as outlined within this document, does not apply to the chimney components or other non-Travis accessories used in conjunction with the installation of this product. If in doubt as to the extent of this warranty, contact your authorized Travis retailer before installation.
9. Travis Industries will not be responsible for inadequate performance caused by environmental conditions such as nearby trees, buildings, roof tops, wind, hills or mountains or negative pressure or other influences from mechanical systems such as furnaces, fans, clothes dryers, etc.
10. Damage to the catalytic combustor due to mishandling, removal, cleaning, or other handling is not covered. Degradation of the combustor due to burning of anything other than natural cord wood is not covered. Burning of trash, garbage, artificial or paper logs, gift wrappings, coal, lighter fluids, chemical starters, treated or painted wood, driftwood or chemical cleaners will void the combustor warranty. These items contain chemicals that may cause the combustor to become deactivated.
- 11 This Warranty is void if:
 - a. The appliance has been operated in atmospheres contaminated by chlorine, fluorine or other damaging chemicals.
 - b. The appliance is subject to submersion in water or prolonged periods of dampness or condensation.
 - c. Any damage to the appliance, combustion chamber, heat exchanger or other components due to water, or weather damage which is the result of, but not limited to, improper chimney/venting installation.
12. Exclusions to this Warranty include: injury, loss of use, damage, failure to function due to accident, negligence, misuse, improper installation, alteration or adjustment of the manufacturer's settings of components, lack of proper and regular maintenance, damage incurred while the appliance is in transit, alteration, or act of God.
13. This warranty excludes damage caused by normal wear and tear, such as paint discoloration or chipping, worn or torn gasketing, chipped or cracked firebrick, etc. Also excluded is damage to the appliance caused by abuse, improper installation, modification of the appliance, or the use of fuel other than that for which the appliance is configured (use cord wood only).
14. Damage to brass or plated surfaces caused by fingerprints, scratches, melted items, or other external sources left on the surfaces from the use of abrasive cleaners is not covered in this warranty. Damage to the surfaces from over-firing (operation where the steel may glow red) is not covered in this warranty.
15. TRAVIS INDUSTRIES, INC. is free of liability for any damages caused by the appliance, as well as inconvenience expenses and materials. Incidental or consequential damages are not covered by this warranty. In some states, the exclusion of incidental or consequential damage may not apply.
16. This warranty does not cover any loss or damage incurred by the use or removal of any component or apparatus to or from the Travis appliance without the express written permission of TRAVIS INDUSTRIES, INC. and bearing a TRAVIS INDUSTRIES, INC. label of approval. This warranty does not cover a stove repaired by someone other than a Travis Industries authorized dealer.
17. Any statement or representation of Travis products and their performance contained in Travis advertising, packaging literature, or printed material is not part of this warranty.
18. This warranty is automatically voided if the appliance's serial number has been removed or altered in any way. If the appliance is used for commercial purposes, it is excluded from this warranty.
19. No dealer, distributor, or similar person has the authority to represent or warrant Travis products beyond the terms contained within this warranty. TRAVIS INDUSTRIES, INC. assumes no liability for such warranties or representations.
20. Travis Industries will not cover the cost of the removal or re-installation of hearths, facing, mantels, venting or other components.
21. If for any reason any section of this warranty is declared invalid, the balance of the warranty remains in effect and all other clauses shall remain in effect.
22. This warranty is the only warranty supplied by Travis Industries, Inc., the manufacturer of the appliance. All other warranties, whether express or implied, are hereby expressly disclaimed and purchaser's recourse is expressly limited to the warranties set forth herein.

IF WARRANTY SERVICE IS NEEDED:

1. If you discover a problem that you believe is covered by this warranty, you MUST REPORT it to your Travis dealer WITHIN 30 DAYS, giving them proof of purchase, the purchase date, and the model name and serial number.
2. Travis Industries has the option of either repairing or replacing the defective component.
3. If your dealer is unable to repair your appliance's defect, he may process a warranty claim through TRAVIS INDUSTRIES, INC., including the name of the dealership where you purchased the appliance, a copy of your receipt showing the date of the appliance's purchase, and the serial number on your appliance. At that time, you may be asked to ship your appliance, freight charges prepaid, to TRAVIS INDUSTRIES, INC. TRAVIS INDUSTRIES, INC., at its option, will repair or replace, free of charge, your appliance if it is found to be defective in material or workmanship within the time frame stated within this warranty. TRAVIS INDUSTRIES, INC. will return your appliance, freight charges (years 1 to 3) prepaid by TRAVIS INDUSTRIES, INC., to your regional distributor, or dealership.
4. Check with your dealer in advance for any costs to you when arranging a warranty call. Mileage or service charges are not covered by this warranty. This charge can vary from store to store.
5. Any appliance or part thereof that is repaired or replaced during the limited warranty period will be warranted under the terms of the limited warranty for a period not to exceed the remaining term of the original limited warranty or six(6) months, whichever is longer.

Listing Label



CAUTION: HOT WHILE IN OPERATION. DO NOT TOUCH. KEEP CHILDREN AND CLOTHING AWAY. CONTACT MAY CAUSE SKIN BURNS. SEE NAMEPLATE AND INSTRUCTIONS. KEEP FURNISHINGS AND COMBUSTIBLE MATERIAL A CONSIDERABLE DISTANCE AWAY. DO NOT OVERFIRE. IF HEATER OR CHIMNEY CONNECTOR GLOWS, YOU ARE OVERFIRING. INSPECT AND CLEAN CHIMNEY FREQUENTLY. UNDER CERTAIN CONDITIONS OF USE, CREOSOTE BUILDUP MAY OCCUR RAPIDLY. DO NOT USE GRATE OR ELEVATE FIRE. BUILD WOOD FIRE DIRECTLY ON HEARTH. OPERATE ONLY WITH FIREBRICK IN PLACE. OPERATE ONLY WITH DOOR CLOSED. OPEN FEED DOORS TO FEED FIRE ONLY. USE OF OTHER FUELS MAY DAMAGE THE HEATER AND CREATE A HAZARDOUS CONDITION.

FOR USE WITH SOLID WOOD FUEL ONLY.

DO NOT REMOVE THIS LABEL

CONTACT LOCAL BUILDING OR FIRE OFFICIALS ABOUT INSTALLATION AND RESTRICTIONS IN YOUR AREA.
SUITABLE FOR USE IN FACTORY-BUILT (Z.C.) FIREPLACES AND MASONRY FIREPLACES.



MODEL:
SMALL FLUSH WOOD
with Hybrid-Fyre™
Certified for USA and Canada

SERIAL NO:

CONFORMS TO UL STD 1482; CERTIFIED TO ULC STD S628-1993

FACTORY-BUILT (Z.C.) FIREPLACE OR MASONRY FIREPLACE INSTALLATION

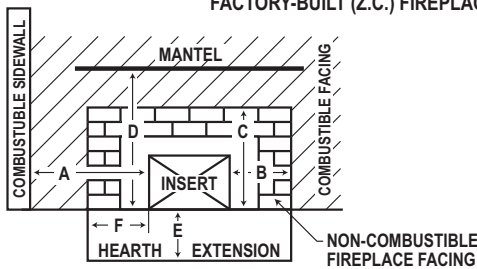

Minimum Clearance to Combustibles and Hearth Requirements	Masonry Fireplace Installations	Factory-Built (Z.C.) Fireplace Installations
A.	11.625 in. / 296 mm	11.625 in. / 296 mm
B.	6.25 in. / 159 mm	6.25 in. / 159 mm
*C.	37.5 in. / 953 mm	37.5 in. / 953 mm
*D.	37.5 in. / 953 mm	37.5 in. / 953 mm
*E. (US)	16 in. / 407 mm	16 in. / 407 mm
*E. (CAN)	18 in. / 458 mm	18 in. / 458 mm
F. (US)	6 in. / 153 mm	6 in. / 153 mm
F. (CAN)	8 in. / 204 mm	8 in. / 204 mm

* From the base of Fireplace Insert.

Factory-Built (Z.C.) Fireplace installations require a fireplace chimney full re-line. Factory-Built (Z.C.) Fireplace chimney must have a minimum cross-sectional area of 28.85 square inches / 733 square mm. A non-combustible hearth floor protection is also required that provides a thermal resistance with an R value equal to 1.19 or greater (see chart above and / or owner's manual for required sizing details).

Minimum 6 in. / 153 mm diameter Stainless Steel liner, full re-line required.

In Canada; a fireplace insert shall be installed with a continuous chimney liner extending from the fireplace insert to the top of the chimney. A chimney liner shall be tested for conformance with Class 3 requirements of CAN/ULC-S635, Standard for Lining Systems for Existing Masonry or Factory-Built Chimneys and Vents, or CAN/ULC-S640, Standard for Lining Systems for New Masonry Chimneys.

PREVENT HOUSE FIRES - Install and use only in accordance with the manufacturer's installation and operating instructions. Contact your local building or fire officials about restrictions and installation inspection in your area. Do not connect this unit to a chimney flue serving another appliance.

This wood heater contains a catalytic combustor, which needs periodic inspection and replacement for proper operation. Consult owner's manual for further information. It is against the law to operate this wood heater in a manner inconsistent with operating instructions in the owner's manual, or if the catalytic element is deactivated or removed. **CAUTION:** the combustor used in this appliance (part no. 174-01111) is fragile and must be handled carefully. Burning of metal foils, plastic, garbage, sulphur and diesel oil will render the catalyst in the combustor inactive. The performance and durability of the catalytic combustor has not been evaluated as part of the certification.

Electrical Rating: 115V, 60 Hz, 1.8 Amps
Blowers: # 228-10069 / 228-10070
Do not route power cord under or in front of appliance.
Replace glass only with 5mm neoceramic or ceramic glass.



Manufactured by:
TRAVIS INDUSTRIES, INC.
12521 Harbour Reach Drive
Mukilteo, WA 98275
www.travisproducts.com

U.S. ENVIRONMENTAL PROTECTION AGENCY
Certified to comply with 2015 particulate emission standards. Not approved for sale after May 15, 2020. 0.89 g/h, Method 28, 5G2, 2015

DATE OF MANUFACTURE

Made in U.S.A. 2015 2016 2017 2018 Jan Feb Mar Apr May Jun Jul Aug Sep Oct Nov Dec 1049

Additional Accessories Needed for Installation..	7	Hearth Requirements.....	10
Additional Requirements for Canada	7	Heating Specifications	6
Adjusting the Burn Rate	25	Hints for Burning	28
Air Tube Removal & Replacement.....	37	Important Information.....	2
Baffle Parts.....	36	Insert Placement Requirements	9
Baffle Removal.....	36	Installation Options	6
Before Your First Fire.....	20	Introduction	2
Blower and Electrical Parts	35	Listing Label.....	43
Blower Operation	27	Masonry Fireplace Requirements.....	10
Brick Removal & Replacement	38	Monthly Maintenance (while appliance is in use)	
Bypass Operation.....	22	32
Clean the Glass.....	31	Normal Operating Sounds	27
Cleaning the Air Duct and Blower	34	Opening the Door.....	21
Cleaning the Catalytic Combustor	33	Over-Firing the Stove.....	20
Combustor.....	36	Overnight Burn.....	27
Creosote - Formation and Need for Removal..	32	Packing List.....	7
Curing the Paint	20	Planning the Installation.....	7
Daily Maintenance (while stove is in use)	31	Preparation for Installation.....	7
Dimensions	6	Re-Loading the Stove	27
Do Not Burn List.....	29	Remove Ash	31
Door and Glass Inspection.....	32	Replacing the Door Gasket.....	35
Door Latch Adjustment.....	32	Replacing the Glass.....	35
Door Parts	35	Re-Routing the Electrical Cord to the Left Side	
Drafting Performance.....	12	19
Emissions and Efficiency	6	Safety Notice.....	20
Face Installation and Removal.....	18	Selecting Wood.....	28
Features	6	Starting a Fire	24
Firebox Parts.....	36	Surround Panel Installation.....	18
Firebrick and Baffle Inspection.....	34	Touch-Up Paint.....	34
Fireplace Altered Tag.....	8	Troubleshooting	30
Fireplace Requirements	8	Verify the Installation	20
Flue Adapter Installation	13	Wood Cutting and Storage	28
GreenStart™ Igniter – Firebrick Installation	39	Yearly Maintenance	34