

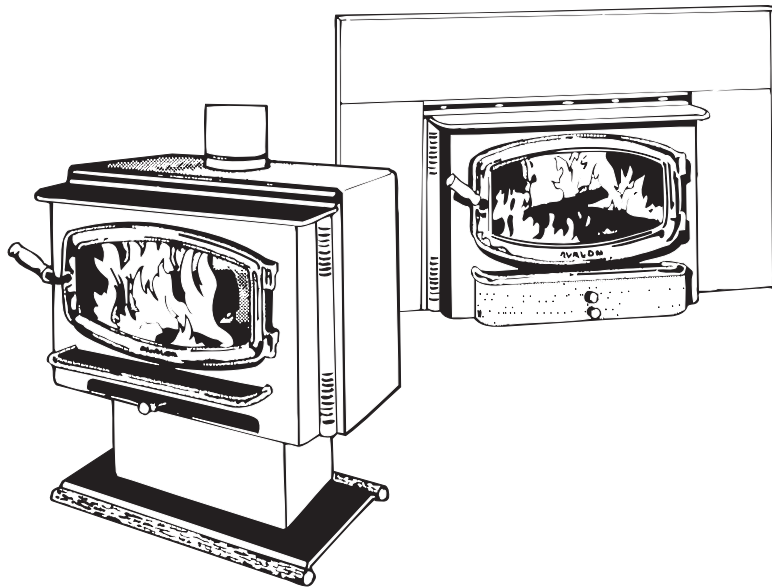

AVALONTM
Firestyles for Life



Olympic (1190)

Wood Stove and Fireplace Insert

- Residential Freestanding Stove
- Mobile-Home Freestanding Stove
- Alcove Approved
- Hearth-Stove Approved
- Masonry Fireplace Insert

Save these instructions
for future reference

SAFETY NOTICE:

If this appliance is not properly installed, a house fire may result. For your safety, follow the installation directions. Contact local building or fire officials about restrictions and installation inspection requirements in your area.



TRAVIS INDUSTRIES
HOUSE OF FIRE

Owner's Manual

© Copyright 2015, T.I.
\$10.00 93508061
4150520



Intertek
Tested to:
ANSI Z21.88 CSA 2.33

Introduction

We welcome you as a new owner of an Avalon Olympic wood-burning stove. In purchasing an Avalon Olympic you have joined the growing ranks of concerned individuals whose selection of an energy system reflects both a concern for the environment and aesthetics. The Avalon Olympic is one of the finest appliances the world over. This manual will explain the installation, operation, and maintenance of this appliance. Please familiarize yourself with the Owner's Manual before operating your appliance and save the manual for future reference. Included are helpful hints and suggestions which will make the installation and operation of your new appliance an easier and more enjoyable experience. We offer our continual support and guidance to help you achieve the maximum benefit and enjoyment from your appliance.

Important Information

No other Avalon Olympic appliance has the same serial number as yours. The serial number is stamped onto the label on the back of the appliance.

This serial number will be needed in case you require service of any type.

Model: Avalon Olympic

Serial Number: _____

Purchase Date: _____

Purchased From: _____

Register your warranty online at:

traviswarranty.com

Or, mail your warranty card to:

Travis Industries House of Fire
12521 Harbour Reach Drive
Mukilteo, WA 98275

Save Your Bill of Sale.

To receive full warranty coverage, you will need to show evidence of the date you purchased your heater. Do not mail your Bill of Sale to us.

We suggest that you attach your Bill of Sale to this page so that you will have all the information you need in one place should the need for service or information occur.



NATIONAL FIREPLACE INSTITUTE
NFI
CERTIFIED
www.nficertified.org

We suggest that our woodburning hearth products be installed and serviced by professionals who are certified in the U.S. by the National Fireplace Institute® (NFI) as NFI Woodburning Specialists or who are certified in Canada by Wood Energy Technical Training (WETT).



Wood Energy Technical Training
www.wettinc.ca

General Information

Introduction & Important Information	2
Safety Precautions	4
Features & Specifications	6

Stove Installation

Planning The Installation	7
Floor Protection Requirements	8
Stove Placement Requirements	8
Clearances	8
Chimney Requirements	10
Chimney Termination Requirements	11
Outside Air Requirements	11
Alcove Installation Requirements	12
Mobile Home Requirements	13

INSTALLATION DIAGRAMS

Standard Ceiling with a Factory Built Chimney	14
Cathedral Ceiling with a Factory Built Chimney	14
Exterior Factory Built Chimney	15
Hearth Stove Positive Connection	15
Hearth Stove Direct Connection	16
Interior Masonry Chimney	16

Fireplace Insert Installation

Planning The Installation	17
Preparation for Installation	17
Additional Accessories Needed for Installation	17
Standard vs. Cook-Top Installations	17
Installation Considerations	17
Top Air Chamber Extension	18
Fireplace Requirements	19
Insert Placement Requirements	20
Hearth Requirements	20
Masonry Fireplace Requirements	20
Leveling Bolt Installation	19
Block-Off Plate Installation	21
Insert with Positive Connection	22
Insert with Direct Connection (Masonry Fireplace)	22
Insert with Face Seal Connection	23

Operating Your Appliance

Safety Notice	24
Before Your First Fire	24
Opening the Door	24
Bypass Operation	26
Starting a Fire	27
Adjusting the Burn Rate	28
Ash Removal	29
Optional Blower Operation	30
Re-Loading the Stove	30
Overnight Burn	30
Normal Operating Sounds	30
Hints for Burning	31
Selecting Wood	31
Troubleshooting	32

Maintaining Your Appliance

Daily Maintenance	34
Remove Ash	34
Clean The Glass	34
Monthly Maintenance	35
Door and Glass Inspection	35
Check For Creosote Buildup	35
Yearly Maintenance	36
Touch Up Paint	36
Blower Cleaning	36
Firebrick and Baffle Inspection	36
Door Parts	37
Replacing the Glass	37
Replacing the Door Gasket	37
Replacing the Door Handle	37
Firebox Parts	38
Floor & Side Firebrick Removal & Replacement	38
Baffle Removal and Replacement	39
Air Tube Removal and Replacement	39

Warranty 40

Listing Information 41

Optional Equipment

Stove Legs	42
Pedestal	42
Rear Blower Installation	44
Outside Air Boot Installation	45
Surround Panels	46
Front Blower	47

Index 48

Safety Precautions

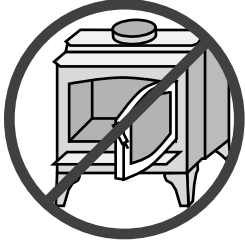

The viewing door must be closed and latched during operation.

Never block free airflow through the air vents on this appliance.



Gasoline or other flammable liquids must never be used to start the fire or "Freshen Up" the fire. Do not store or use gasoline or other flammable liquids in the vicinity of this appliance.

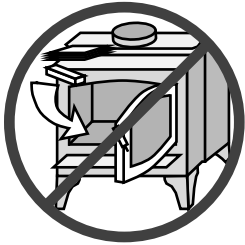

This appliance is designed and approved for the burning of cord wood only. Do not attempt to burn any other type of fuel other than cord wood in this appliance, it will void all warranties and safety listings.



Ashes must be disposed in a metal container with a tight lid and placed on a non-combustible surface well away from the home or structure.



Do not touch the appliance while it is hot and educate all children of the danger of a high-temperature appliance. Young children should be supervised when they are in the same room as the appliance.

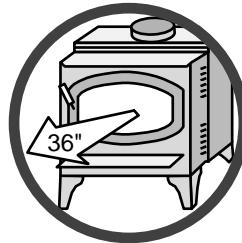

Keep furniture, drapes, curtains, wood, paper, and other combustibles a minimum of 36" away from the front of the appliance.



This appliance must be properly installed to prevent the possibility of a house fire. The instructions must be strictly adhered to. Do not use makeshift methods or compromise in the installation.



Contact your local building officials to obtain a permit and information on any installation restrictions or inspection requirements in your area. Notify your insurance company of this appliance as well.



Inspect the chimney connector and chimney at least twice monthly and clean if necessary. Creosote may build up and cause a house fire.

Do not connect this appliance to any chimney serving another appliance.

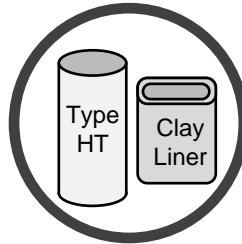

This appliance must be connected to a listed high temperature (UL 103 HT) residential type chimney or an approved masonry chimney with a standard clay tile, or stainless steel liner.



When installed in a mobile home, this appliance must be bolted to the floor, have outside air, and not be installed in the bedroom (Per H.U.D. requirements). Check with local building officials.



Do not place clothing or other flammable items on or near this appliance.

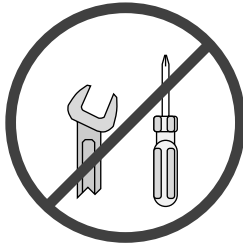

Never try to repair or replace any part of this appliance unless instructions are given in this manual. All other work must be done by a trained technician. Do not make any changes or modifications to an existing masonry fireplace or chimney to install this appliance.

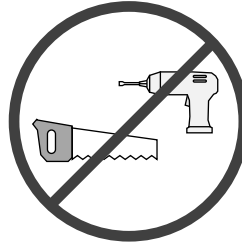

This wood heater has a manufacturer-set minimum low burn rate that must not be altered. It is against federal regulations to alter this setting or otherwise operate this wood heater in a manner inconsistent with operating instructions in this manual.

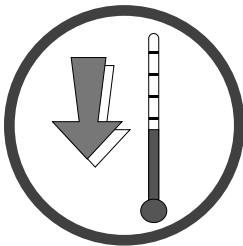

Allow the appliance to cool before carrying out any maintenance or cleaning.

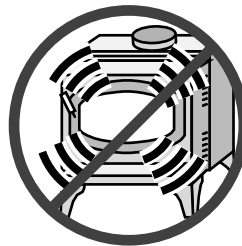

Overfiring the appliance may cause a house fire. If a unit or chimney connector glows, you are overfiring.



Maintain the door and glass seal and keep them in good condition.

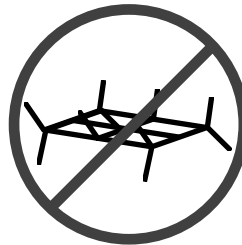

Do not use a grate or other device to elevate the fire off of the firebox floor. Burn the fire directly on the bricks.



Do not throw this manual away. This manual has important operating and maintenance instructions that you will need at a later time. Always follow the instructions in this manual.



Travis Industries, Inc. grants no warranty, implied or stated, for the installation or maintenance of your appliance, and assumes no responsibility of any consequential damage(s).

Smoke and CO Detectors: Make sure your home has a working smoke detector, especially near any bedrooms. We recommend having a smoke and/or CO detector in the same room as the wood heater for additional safety.

Proposition 65 Warning: Fuels used in gas, woodburning or oil fired appliances, and the products of combustion of such fuels, contain chemicals known to the State of California to cause cancer, birth defects and other reproductive harm. California Health & Safety Code Sec. 25249.6

Installation Options

- Freestanding
 - Freestanding in an Alcove
 - Freestanding in a Mobile Home
 - Masonry Fireplace Insert
- NOTE: This fireplace insert is not approved for Factory Built Z.C. (Metal) Fireplaces

Features

- 3.1 Cubic Foot Firebox Volume
- Single Operating Control
- Accepts Logs Up to 24" Long
- Steel Plate Construction (1/4" & 3/16")
- Heavy Duty Refractory Firebrick
- Optional High-Tech Blower

Heating Specifications

Approximate Maximum Heating Capacity (in square feet)*	1,500 to 2,500
Maximum BTU's per Hour (Cord Wood Calculation)	74,300
Overall Efficiency (Oregon Method)	70.0 %
Maximum Burn Time	Up to 12 Hours

* Heating capacity will vary depending on the home's floor plan, degree of insulation, and the outside temperature. It is also affected by the quality and moisture level of the fuel.

This model was not tested for efficiency however it is assigned a default efficiency of 63% by the EPA under previous subpart AAA. Efficiency of this wood heater will be affected by the operational burn rate and the moisture content of the wood used as fuel.

Dimensions

Note:

Measure side, corner, and back clearances from the stove top.

The flue collar protrudes 1" above the stove top

Weight:

510 Lbs. with pedestal

* For inserts, add 1" for the flue collar.

** See "Fireplace Requirements" for details on fireplace insert installation.

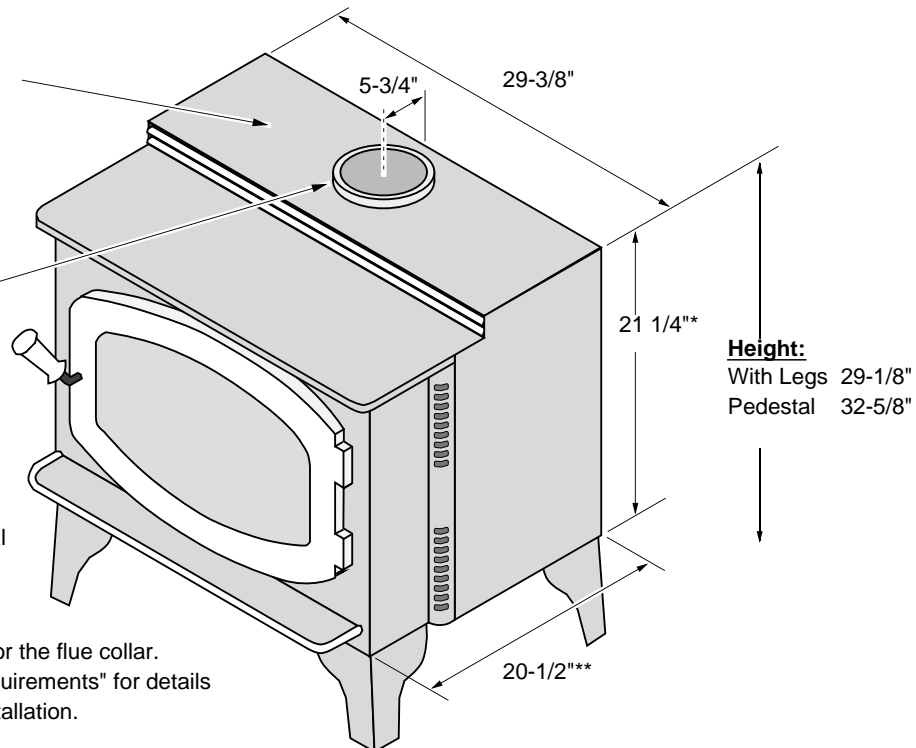

Figure 1

Emissions

This heater meets the 2015 U.S. EPA's crib wood emission limits for wood heaters sold after May 15, 2015. Tested to Method 28, 5H this heater has been shown to deliver heat at rates ranging from 12,000 to 45,100 BTU/hr and an emission value of 2.6g/h.

SAFETY NOTICE:

Please read this entire manual before you install and use your new room heater. Failure to follow instructions may result in property damage, bodily injury, or even death. Contact local building or fire officials about restrictions and installation inspection requirements in your area.

Planning The Installation



We suggest that you have an authorized Travis Industries dealer install your stove. If you install the stove yourself, your authorized dealer should review your installation plans.



Check with local building officials for any permits required for installation of this stove and notify your insurance company before proceeding with installation.



The location of your wood heater in your home will decide how affectively the heat produced will spread throughout your house. Attention to the home design with consideration of natural convection and air circulation should be taken into account when choosing the placement of your heater within the home.

Preparation for Installation

- Check for damage to the exterior of the stove (dents should be reported, scratches can be fixed by applying touch up paint).
- Check the interior of the firebox (replace cracked firebrick and make sure baffle is in place).



The stove can be lightened by removing the firebricks and baffle (pg 38) - replace before operation.

Additional Accessories Needed for Installation

- Legs or Pedestal

Packing List

- Top Air Chamber Extension (used for inserts only)
- Damper Rod (for the Top Air Chamber Extension)
- (4) Screws (for the Top Air Chamber Extension)
- Pull Tool (used to adjust the damper when hot)

Stove Installation Considerations

The table below details the six most common types of installations and the considerations for each type. Alternative methods of installation are available if they comply with local building codes.

<u>Installation Type</u>	<u>Considerations</u>
Standard Ceiling with a Factory Built Chimney (Page 14)	<ul style="list-style-type: none"> • Requires ceiling and roof penetration • Provides best draft
Cathedral Ceiling with a Factory Built Chimney (Page 14)	<ul style="list-style-type: none"> • Cathedral style chimney support required • Provides best draft
Exterior Factory Built Chimney (Page 15)	<ul style="list-style-type: none"> • Uses two elbows to route chimney outside • Exterior chimney is hidden from the room • Elbows reduce draft • Optional exterior chase reduces cold air blockage
Hearth Stove Positive Connection (Page 15)	<ul style="list-style-type: none"> • Utilizes existing masonry chimney • Provides good draft due to full reline • Easier to clean than direct or horizontal hearth stove
Hearth Stove Direct Connection (Page 16)	<ul style="list-style-type: none"> • Utilizes existing masonry chimney • Requires construction of a "block-off plate" • Draft reduced due to elbows & chimney cross section
Interior Masonry Chimney (Page 16)	<ul style="list-style-type: none"> • Utilizes existing masonry chimney

Floor Protection Requirements

- Stove must be placed on the Travis Industries legs or Pedestal.
- Floor protection must extend 6" to the sides and rear of the stove and 16" to the front of the stove (41-3/8" wide by 42-1/2" deep - see Figure 2 and Figure 3).
- Floor protection must be non-combustible and at least .018" thick (26 gauge).

Stove Placement Requirements



Clearances may be reduced by methods specified in NFPA 211, listed wall shields, pipe shields, or other means approved by local building or fire officials.

- Stove must be placed so that no combustibles are within, or can swing within (e.g. drapes, doors), 36" of the front of the stove
- If the stove is placed in a location where the ceiling height is less than 7', it must follow the requirements in the section "Alcove Installation Requirements"
- Must maintain the clearances to combustibles listed below (drywall, furniture, etc.):

Clearances

- The following clearances must be met (see Figure 2 and Figure 3)

Minimum Clearance		Singlewall Connector	Reduced Clearance*
A	Sidewall to stove	16"	16"
B	Backwall to stove	15"	10"
C	Cornerwall to stove	9-1/2"	7-1/2"
D	Connector to sidewall	27-3/4"	27-1/4"
E	Connector to backwall	17-3/4"	12-1/4"
F	Connector to cornerwall	21"	18-1/2"

- * **Reduced clearance installations require one of the chimneys and connectors listed below:**

AMERI-TEC model DCC with model HS chimney

DURAVENT model DVL with DURATEC or DURA-PLUS chimney

METALFAB model DW connector with TG chimney

SECURITY model DP connector with SECURITY model ASHT or S2100 chimney

Standard Masonry Chimney with any one of the above listed connectors

NOTE: Reduced clearance connectors may not connect to the flue collar – an appliance adapter may be required.

NOTE: Standard residential installations with reduced clearance connector may use the clearance determined by the manufacturer of the connector for the connector to wall clearance or the clearance listed in this manual. Offsets must be used to maintain the stove to wall clearance.

Top View - Straight Installation

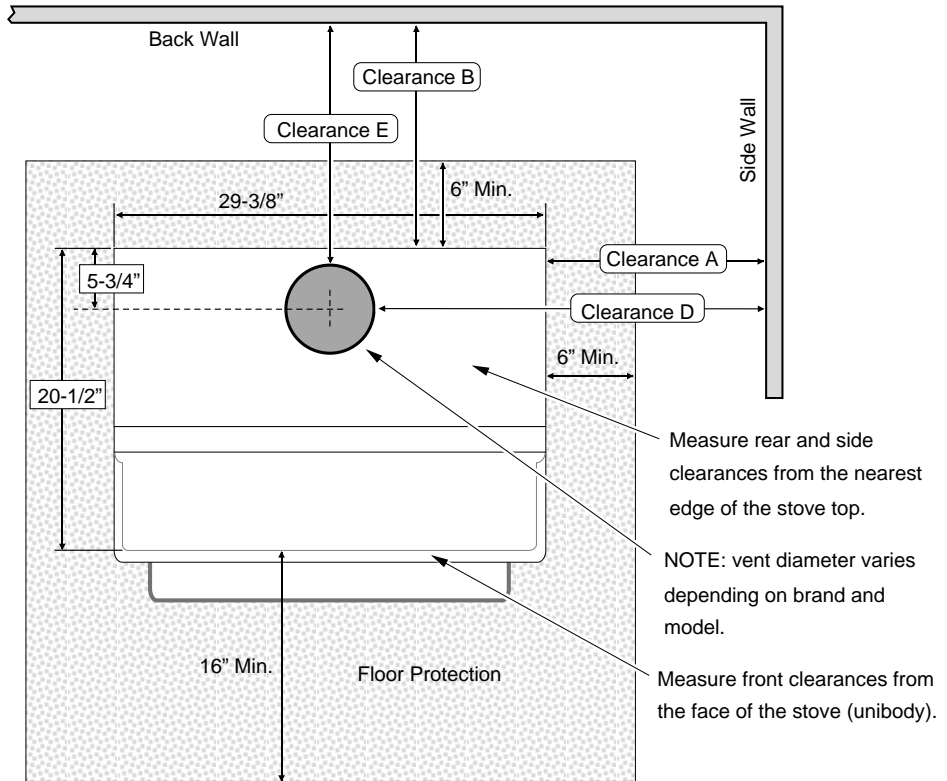

Figure 2

Top View - Corner Installation

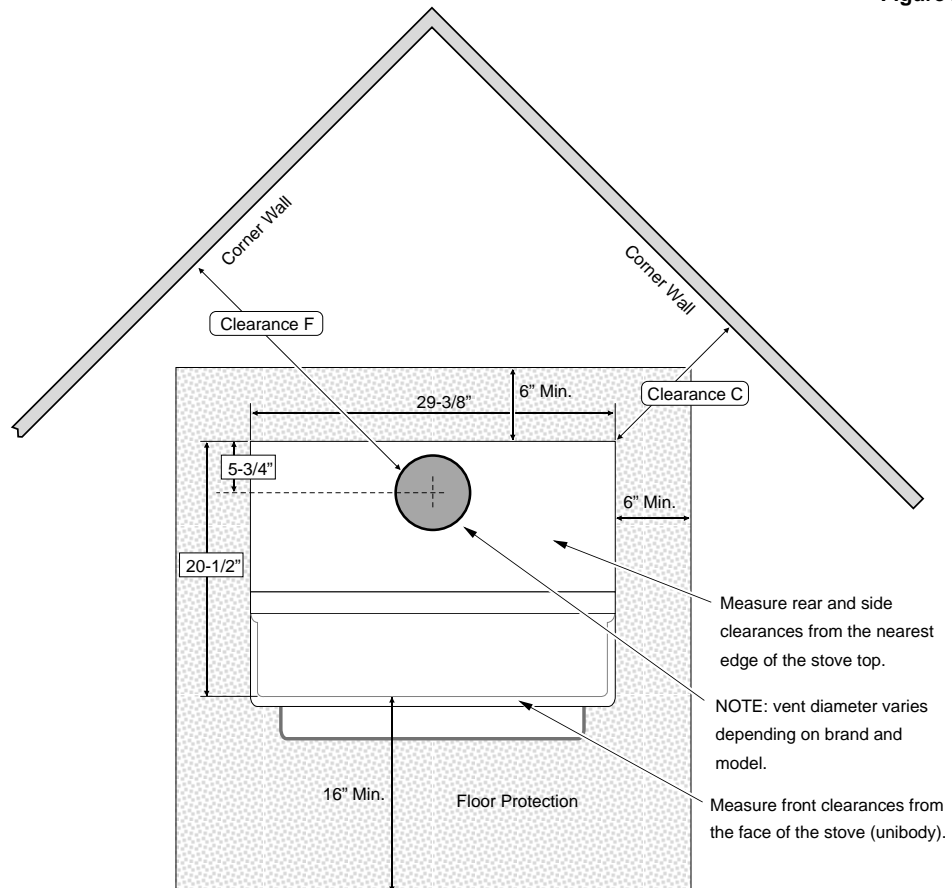

Figure 3

Chimney Requirements

- DO NOT CONNECT THIS UNIT TO A CHIMNEY FLUE SERVING ANOTHER APPLIANCE.
- Chimney connector must be a minimum 24 MSG black or 26 MSG blued steel (6" diameter). Chimney must be used from the first floor or wall penetration to the chimney cap.
- Use 6" diameter type UL 103 HT chimney from one manufacturer (do not mix brands) or code approved masonry chimney with a flue liner.
- Chimney connector and chimney must be fastened to the stove and each adjoining section.
- Follow the chimney manufacturer's clearances and requirements.
- Use the chimney manufacturer's fire stops, attic guards, roof supports, and flashings when passing through a ceiling or thimble when passing through a combustible wall.
- No more than 180° of elbows (two 90° elbows, or two 45° & one 90° elbow, etc.).
- NOTE: Additional elbows may be allowed if draft is sufficient. Whenever elbows are used the draft is adversely affected. Additional chimney height may be required to boost draft.

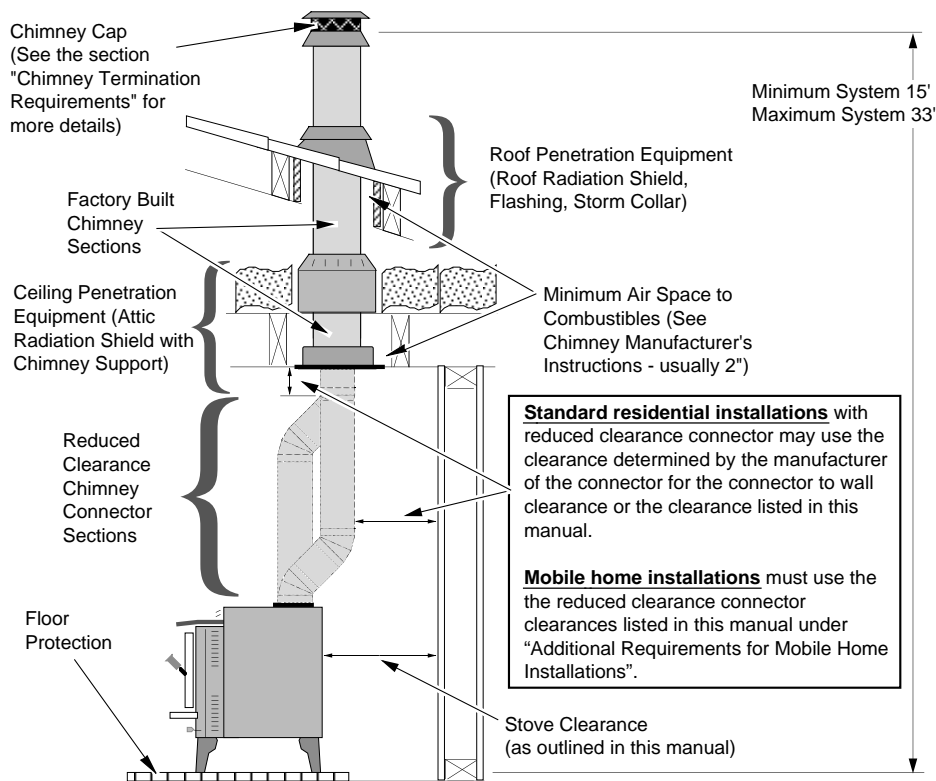

Figure 4

Drafting Performance

Draft is the force which moves air from the appliance up through the chimney. The amount of draft in your chimney depends on the length of the chimney, local geography, nearby obstructions and other factors. Too much draft may cause excessive temperatures in the appliance and may damage the heater. Inadequate draft may cause backpuffing into the room and 'plugging' of the chimney. Inadequate draft will cause the appliance to leak smoke into the room through appliance and chimney connector joints. An uncontrollable burn or excessive temperature indicates excessive draft.

- Standard residential installations may use single-wall connector (Mobile-Homes may **not**)
- Standard residential installations with reduced clearance connector may use the clearance determined by the manufacturer of the connector for the connector to wall clearance or the clearance listed in this manual. Offsets must be used to maintain the stove to wall clearance. Mobile homes must use the clearances listed in this manual under "Additional Requirements for Mobile Home Installations".

Chimney Termination Requirements

- Must have an approved cap (to prevent water from entering)
- Must not be located where it will become plugged by snow or other material
- Must terminate at least 3' above the roof **and** at least 2' above any portion of the roof within 10' (see Figure 5)

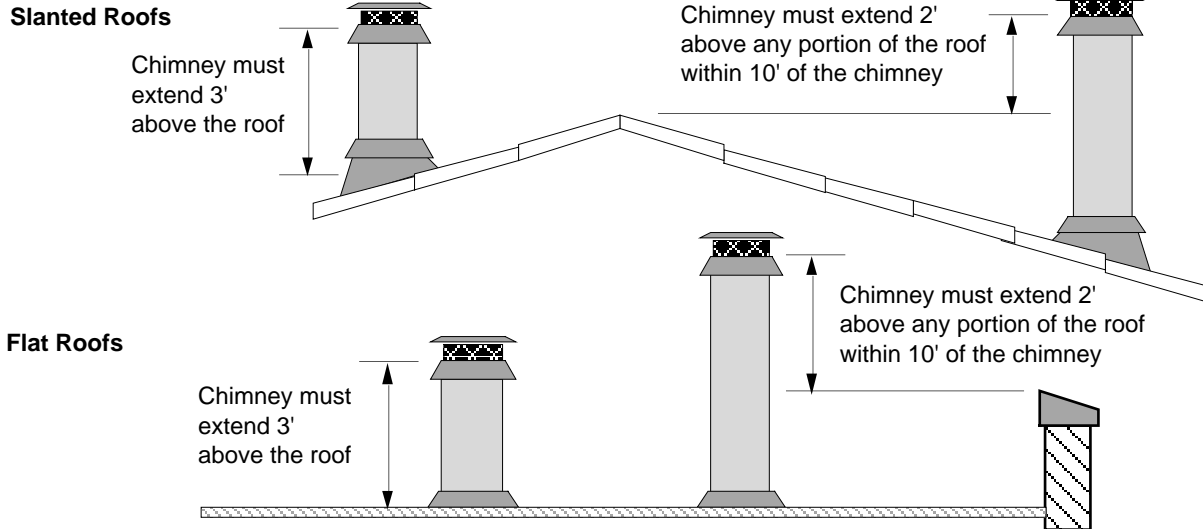

Figure 5

Outside Air Requirements

- Required for mobile homes & in certain localities (check with building officials)
- Must not be drawn from an enclosed space (garage, unventilated crawl space)
- Requires the optional outside air boot (for legs) or pedestal.

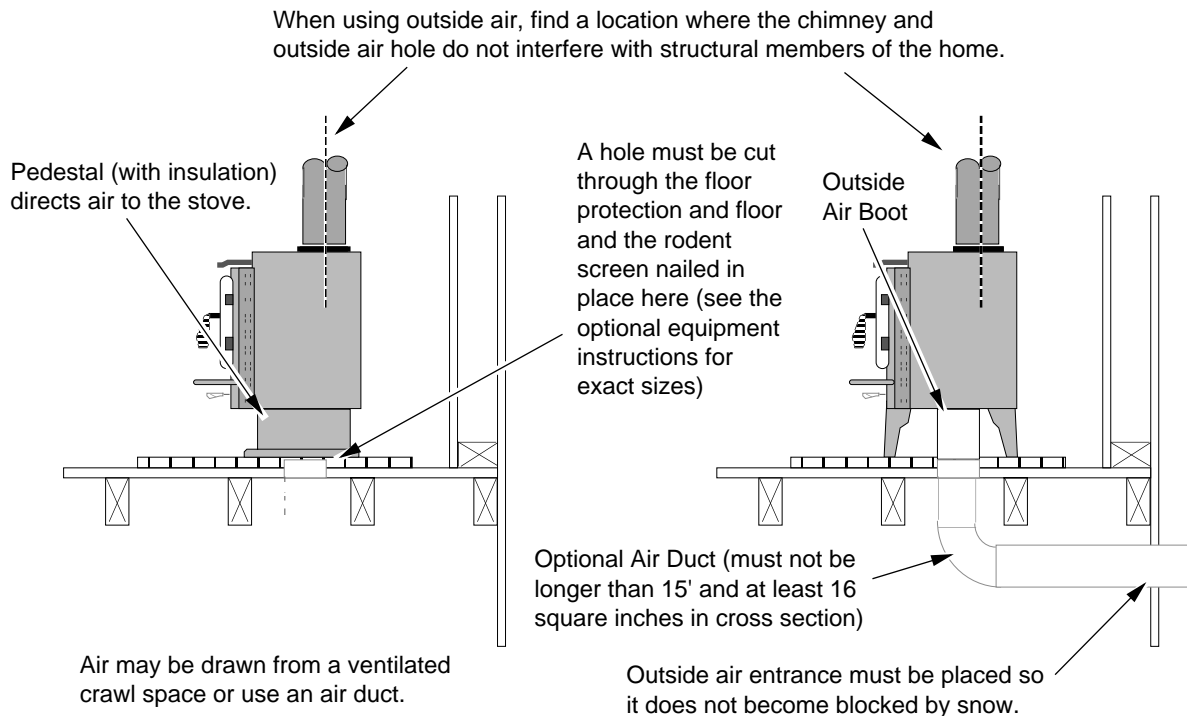

Figure 6

Alcove Installation Requirements

Whenever the stove is placed in a location where the ceiling height is less than 7' tall, it is considered an alcove installation. Because of the reduced height, the special installation requirements listed below must be met.

- Chimney connector and chimney must be one of the following types:

- AMERI-TEC model DCC with model HS chimney
- DURAVENT model DVL with DURATEC or DURA-PLUS chimney
- METALFAB model DW connector with TG chimney
- SECURITY model DP connector with SECURITY model ASHT or S2100 chimney
- Standard Masonry Chimney with any one of the above listed connectors

NOTE: Reduced clearance connectors may not connect to the flue collar – an appliance adapter may be required.

- Alcoves are classified as combustible or non-combustible. Non-combustible alcoves must have walls and a ceiling that are 3 1/2" thick of a non-combustible material (brick, stone, or concrete - see Figure 7). This non-combustible material must be spaced and ventilated at least 1" off of all combustible materials (walls, ceiling, etc.) to allow air to move around the non-combustible walls and ceiling. All other alcoves are considered combustible. The clearances below must be met:

Minimum Clearance (See the Figure 7 below)		Combustible Alcove	Non-Combustible Alcove
A	Sidewall to stove	16"	6"
B	Backwall to stove	10"	2"
D	Connector to sidewall	27-1/4"	17-1/4"
E	Connector to backwall	12-1/4"	4-1/4"
G	Maximum depth of alcove	48"	48"
H	Minimum width of alcove	61-3/8"	41-3/8"
J	Minimum height of alcove	84"	6" above stove top

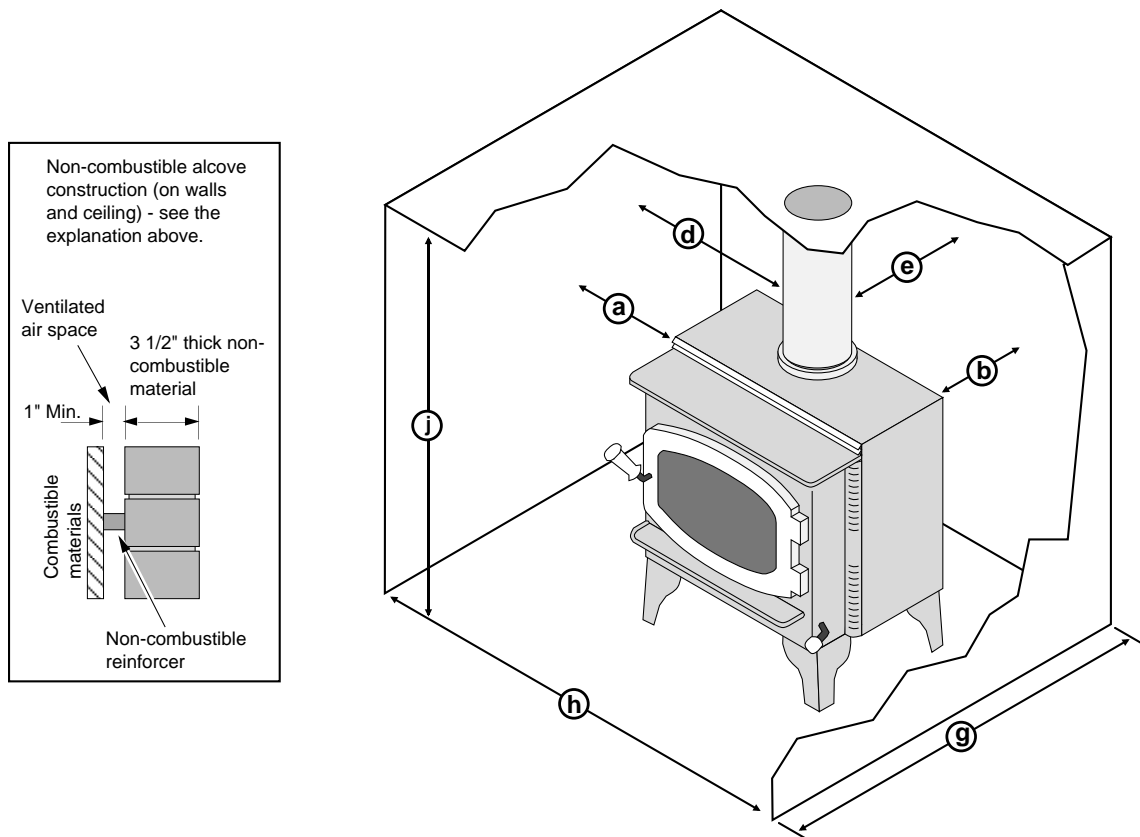

Figure 7

Mobile Home Requirements

- Outside air must be installed - see "Outside Air Requirements" on page 11
- Chimney connector and chimney must be one of the following types:
 - AMERI-TEC model DCC with model HS chimney
 - DURAVENT model DVL with DURATEC or DURA-PLUS chimney
 - METALFAB model DW connector with TG chimney
 - SECURITY model DP connector with SECURITY model ASHT or S2100 chimney
 - Standard Masonry Chimney with any one of the above listed connectors
- NOTE: Reduced clearance connectors may not connect to the flue collar – an appliance adapter may be required.
- Stove placement must maintain the following clearances to combustibles (drywall, furniture, etc.)

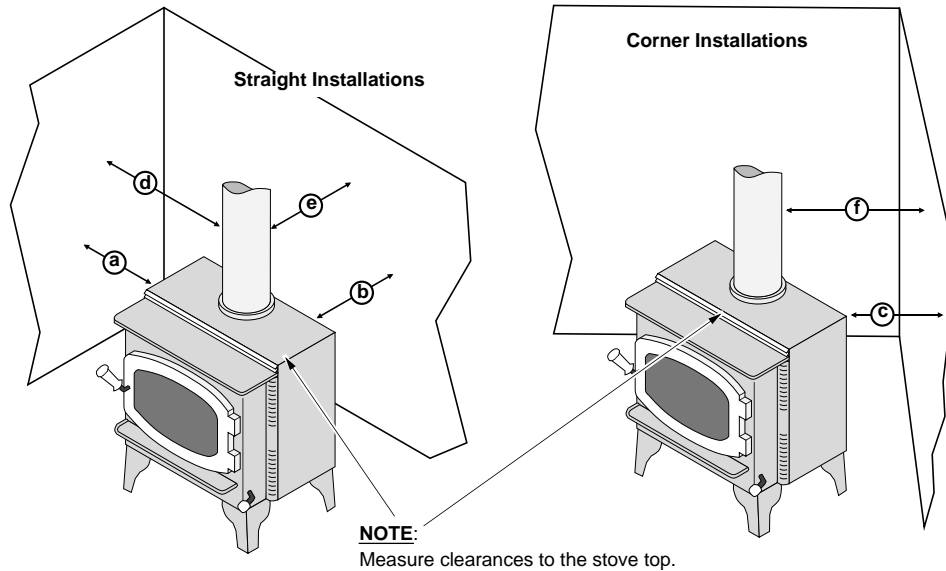

Figure 8

Minimum Clearance (See the illustration above)		Reduced Clearance Connector
A	Sidewall to stove	16"
B	Backwall to stove	10"
C	Cornerwall to stove	7-1/2"
D	Connector to sidewall	27-1/4"
E	Connector to backwall	12-1/4"
F	Connector to cornerwall	18-1/2"

- If using offsets, use the connector clearance listed in Figure 9, **not the connector manufacturer's clearance.**
- The appliance must be secured to the floor (consult your building official). Secure the outside air boot to the floor and stove to insure the stove does not dislocate.
- Mobile home installations require a spark arrester at the chimney termination.
- The appliance must be grounded to the chassis of the mobile home (consult your building official).
- **WARNING:DO NOT INSTALL IN SLEEPING ROOM.**
- **CAUTION:THE STRUCTURAL INTEGRITY OF THE MOBILE HOME FLOOR, WALL, AND CEILING/ROOF MUST BE MAINTAINED.**

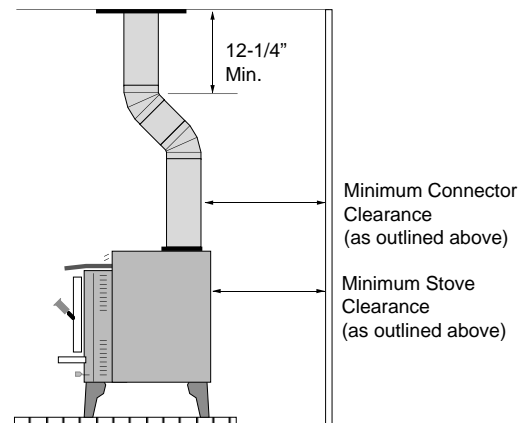

Figure 9

Standard Ceiling with a Factory Built Chimney

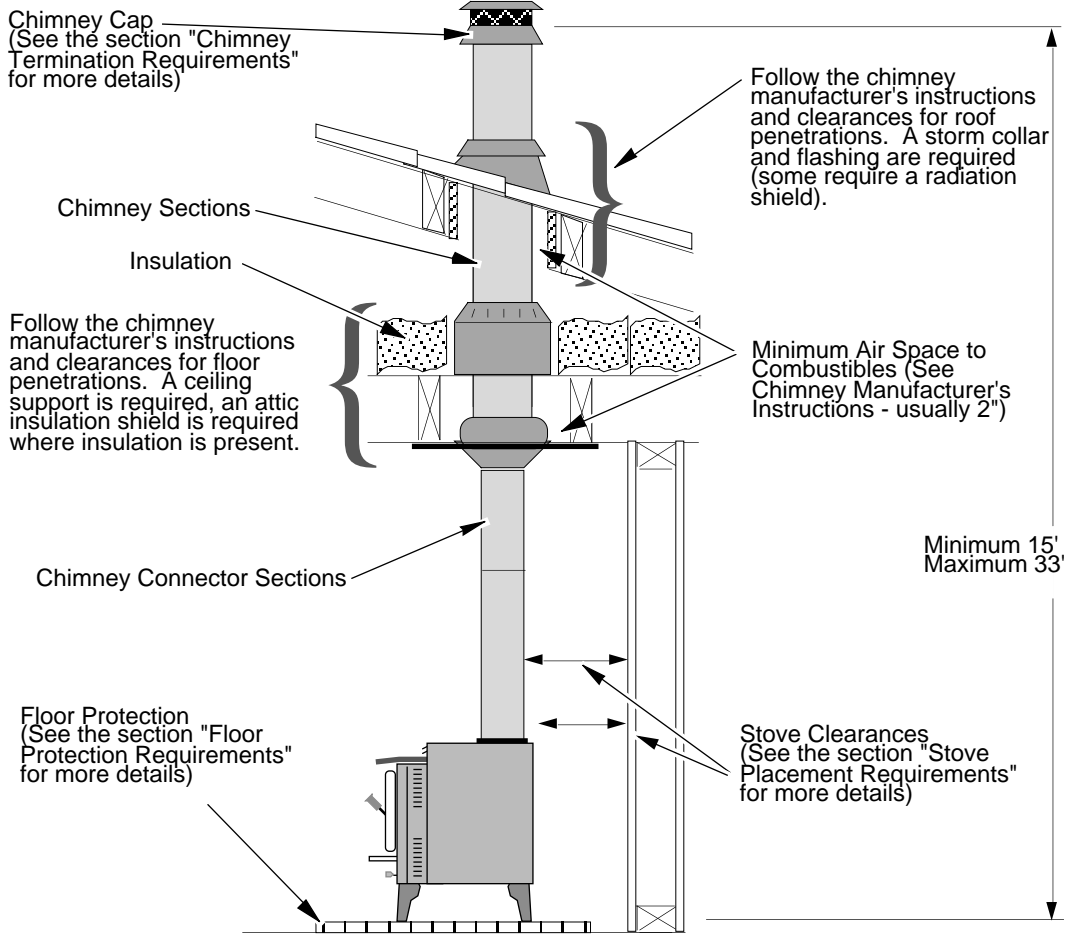

Figure 10

Cathedral Ceiling with a Factory Built Chimney

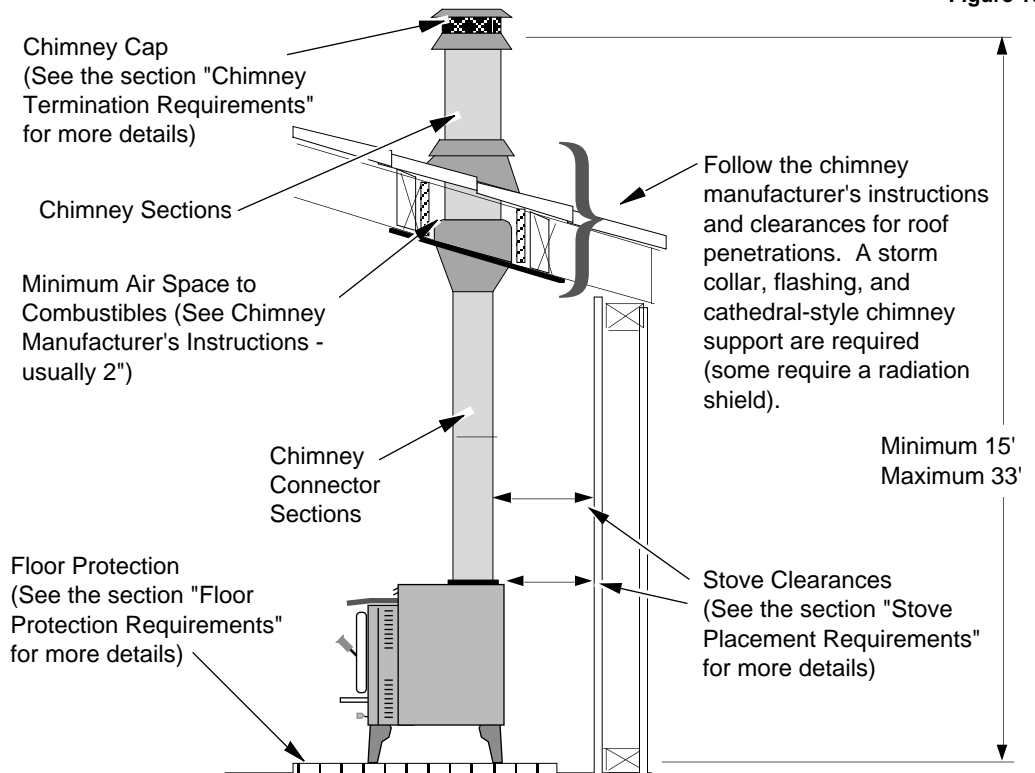

Figure 11

Exterior Factory Built Chimney

NOTE:

Exterior chimneys are subject to greater moisture and creosote accumulation due to the lower temperatures. An insulated chase will reduce these accumulations (the proper clearances to the chimney must be maintained).

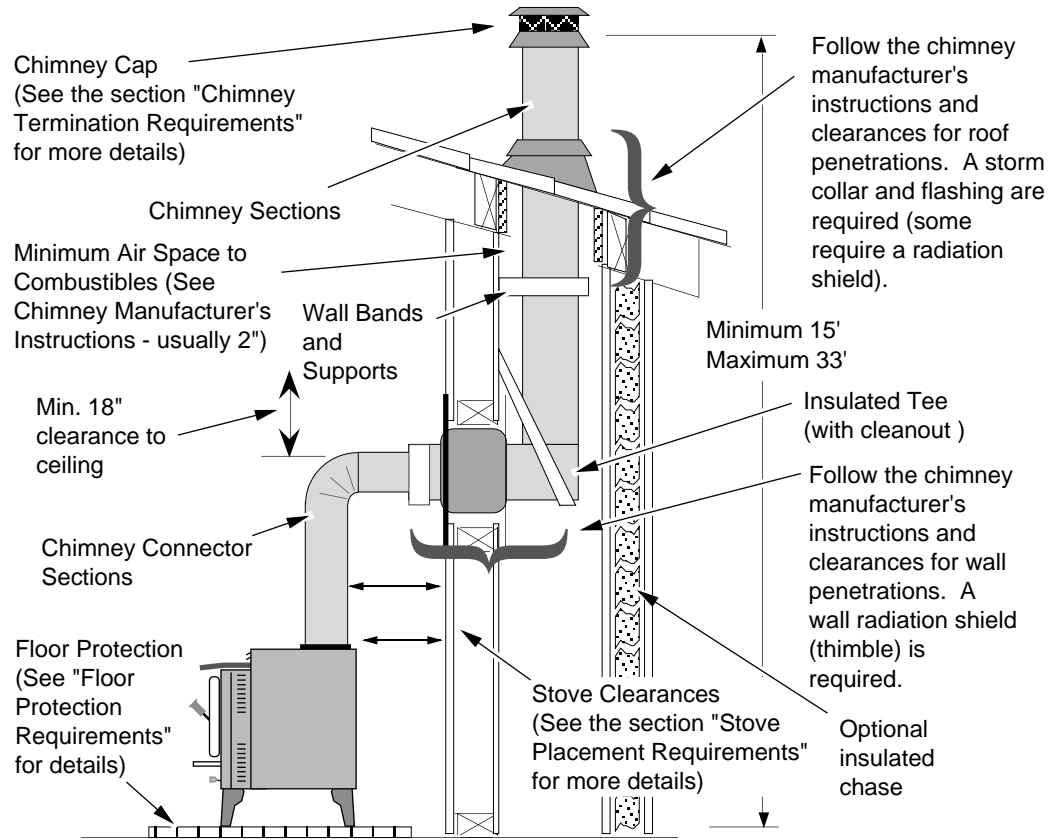

Figure 12

Hearth Stove Positive Connection

NOTE:

Most factory-built chimney manufacturers make stainless steel chimney liners, either flexible or rigid. This provides a wide variety of installation options. Make sure to follow the manufacturer's instructions for installation and support.

NOTE: The entire fireplace and chimney must be clean, undamaged, and meet all local building codes (UBC, etc.). Damage must be repaired prior to installation. The chimney must be 15' to 33' tall.

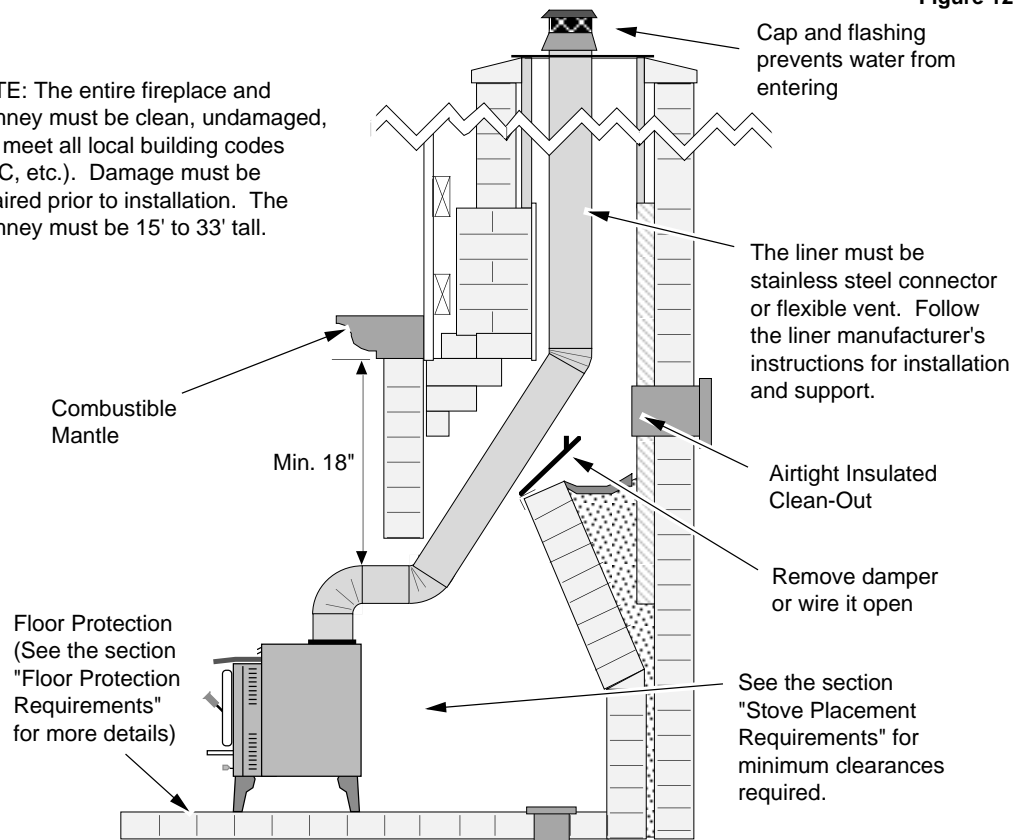

Figure 13

Hearth Stove Direct Connection

NOTE:

Direct connections require installation of an airtight, non-combustible block-off plate or damper adapter.

NOTE: The chimney must have a clay tile liner. If it does not, the installation must use a positive connection (full reline). The entire fireplace and chimney must be clean, undamaged, and meet all local building codes (UBC, etc.). Damage must be repaired prior to installation. The chimney must be 15' to 33' tall.

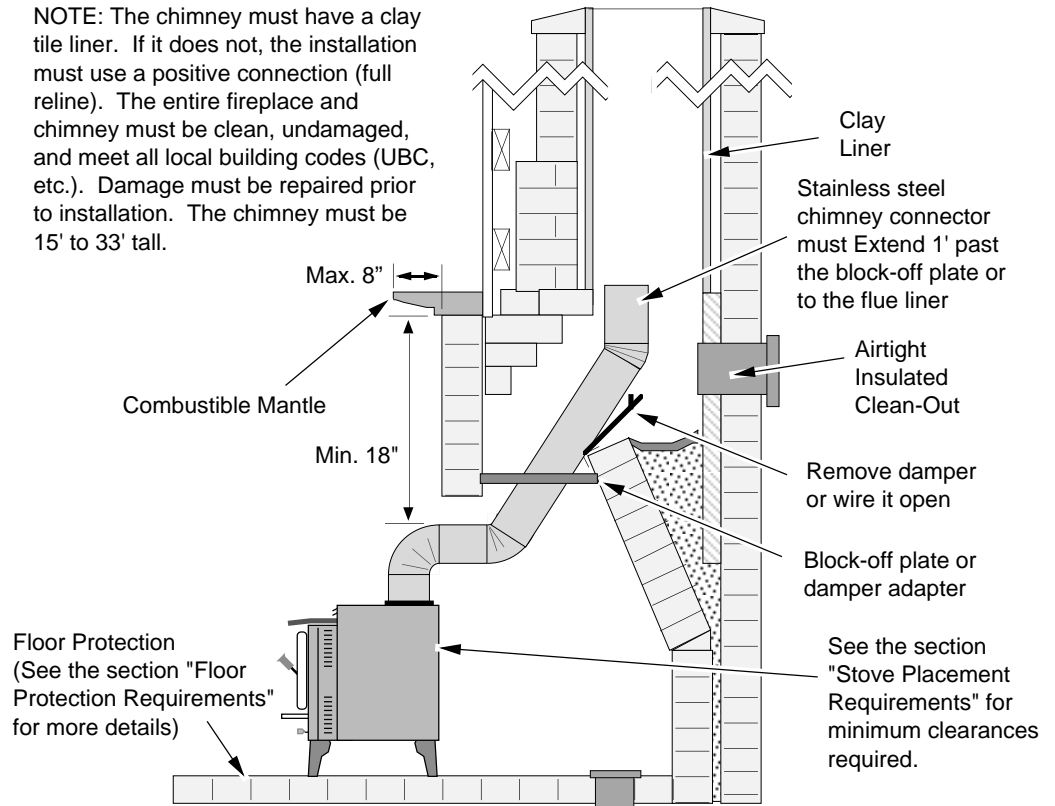

Figure 14

Interior or Exterior Masonry Chimney

NOTE:

This type of installation requires a UBC approved masonry connector or a factory built (U.L. Listed) wall thimble.

NOTE: The chimney must have a clay tile liner. If it does not, the installation must use a positive connection (full reline). The entire fireplace and chimney must be clean, undamaged, and meet all local building codes (UBC, etc.). Damage must be repaired prior to installation. The chimney must be 15' to 33' tall.

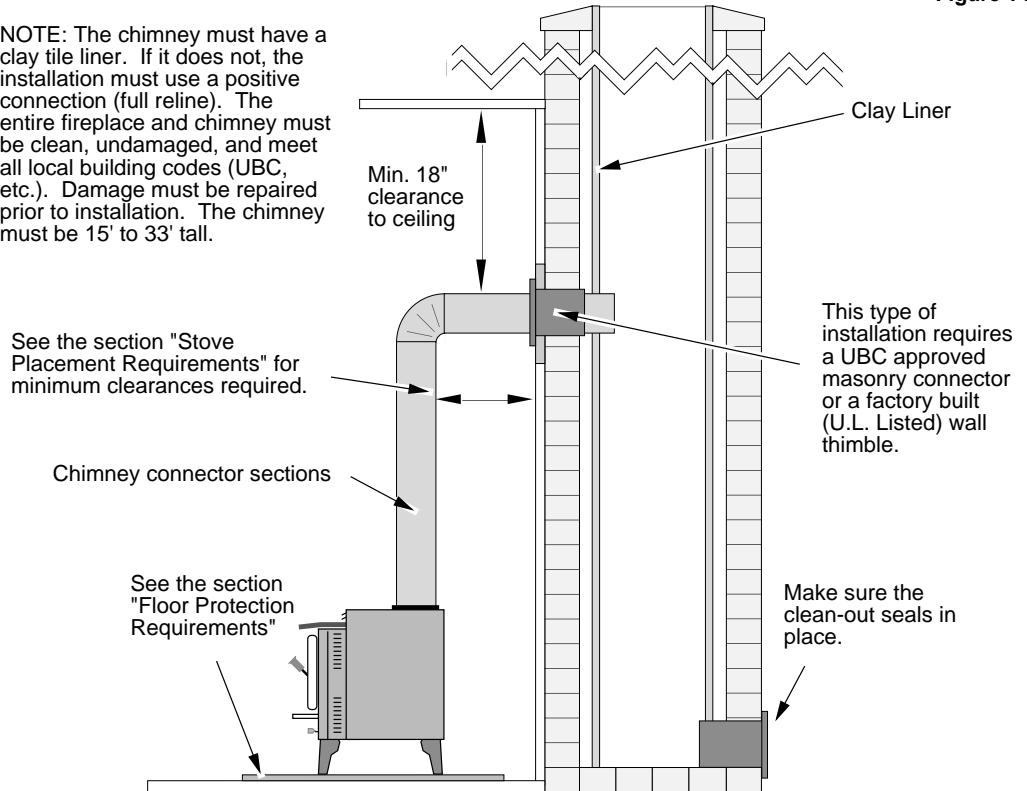

Figure 15

SAFETY NOTICE:

Please read this entire manual before you install and use your new room heater. Failure to follow instructions may result in property damage, bodily injury, or even death. Contact local building or fire officials about restrictions and installation inspection requirements in your area.

Planning The Installation



We suggest that you have an authorized Travis Industries dealer install your fireplace insert. If you install the fireplace insert yourself, your authorized dealer should review your installation plans.



Check with local building officials for any permits required for installation of this fireplace insert and notify your insurance company before proceeding with installation.

Preparation for Installation

- Check for damage to the exterior of the fireplace insert (dents should be reported, scratches can be fixed by applying touch up paint).
- Check the interior of the firebox (replace cracked firebrick and make sure baffle is in place).



The fireplace insert can be lightened by removing the firebricks and baffle (pg 38) - replace before operation.

Additional Accessories Needed for Installation

- Surround Panels (see page 46)

Standard vs. Cook-Top Installations

The top air chamber extension is shipped separately with the heater (see the following page for details). When installed, the unit is considered a "Standard Model" for Insert Placement and Fireplace Requirements. If it is not installed, the unit is considered a "Cook-Top Model" for Insert Placement and Fireplace Requirements.

Installation Considerations

<u>Installation Type</u>	<u>Considerations</u>
Insert with Positive Flue (Full Reline) (Page 22)	<ul style="list-style-type: none"> • Utilizes existing masonry fireplace • Provides best draft • Easiest to clean
Insert with Direct Connect Flue (Page 22)	<ul style="list-style-type: none"> • Utilizes existing masonry fireplace • Provides good draft • Requires fireplace block-off plate - see page 21
Insert with Face Seal Connection (Page 23) NOTE: Before installing verify with local building officials that this type of installation is approved in your area.	<ul style="list-style-type: none"> • Utilizes existing masonry fireplaces with cross section of 28" to 144" • Provides marginal draft • Easiest to install • Requires the optional surround panels and insulation (see "Surround Panels" on page 46).

Top Air Chamber Extension

The top air chamber extension is shipped separately with the heater and may be installed when the heater is used as an insert (see "Standard Model" under Insert Placement and Fireplace Requirements). Follow the directions below to install.

1. Remove the grill. Remove and discard the bypass extension rod (keep the pull ring).

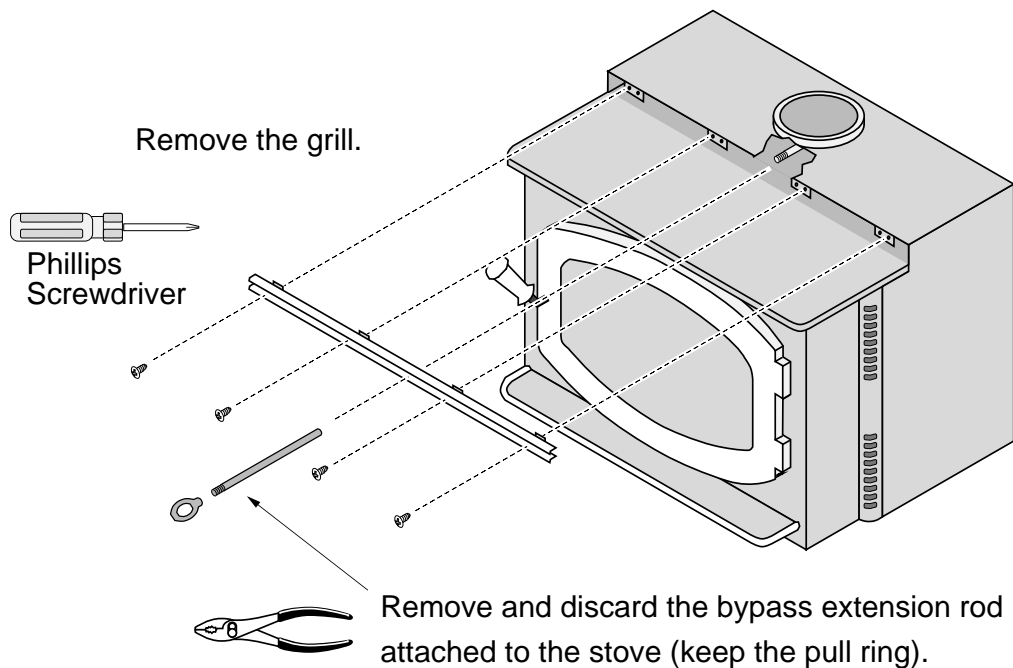

2. Install the top air chamber extension following the directions below.

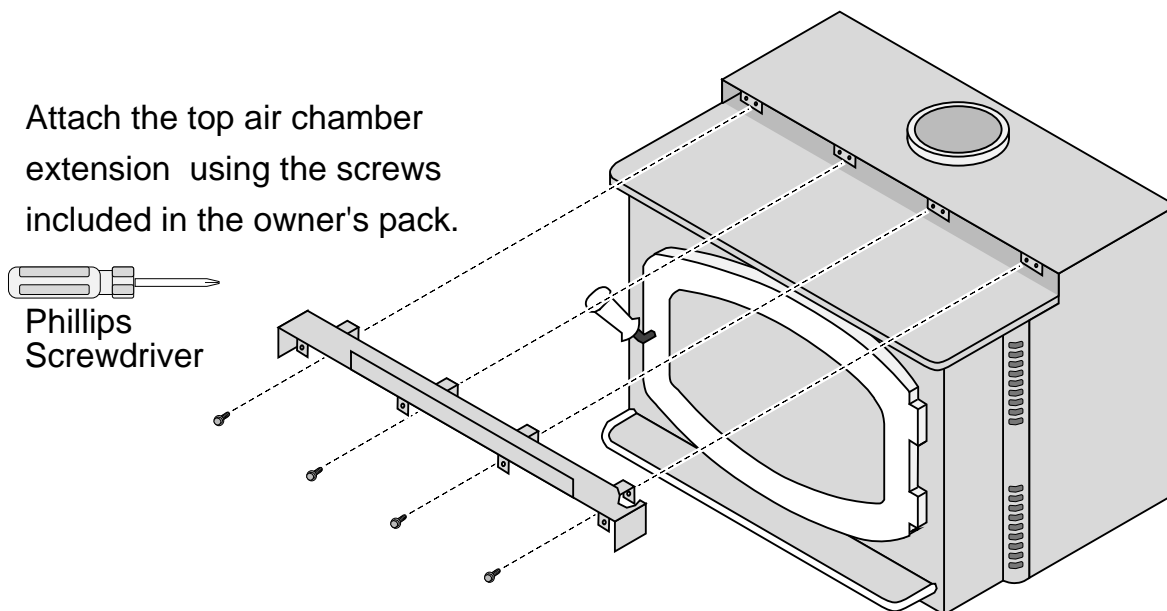

3. Attach the grill to the air chamber top. Attach the bypass extension rod included in the owner's kit to the damper yoke. Attach the bypass pull ring to the extension rod to complete the installation.

Fireplace Requirements

Figure 16 shows the minimum size requirements.

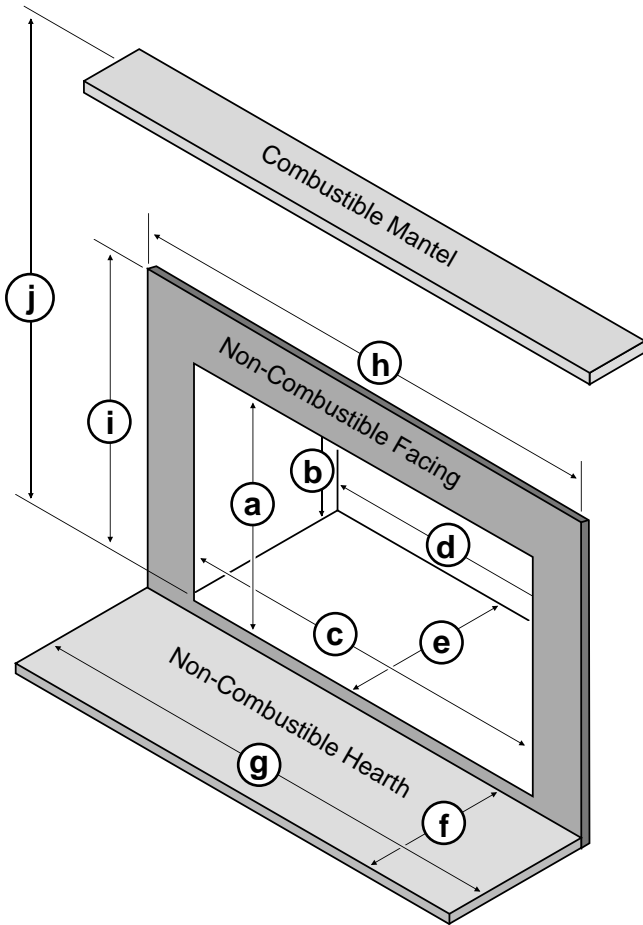

Minimum Fireplace Size

	Standard Model	Cook-Top Model
a Height (front)	22-1/4"	22-1/4"
b Height (rear)	22-1/4"	22-1/4"
c Width (front)	29-3/8"	29-3/8"
d Width (rear)	29-3/8"	29-3/8"
e Depth	14-1/8"	11-5/8"
f Hearth Depth*	22-3/8"	24-7/8"
g Hearth Width	45-3/8"	45-3/8"
h Facing Width	56-3/8"	56-3/8"
i Facing Height	51-1/4"	52-1/4"
with Mantel Shield	38-1/4"	39-1/4"

* This is the distance the insert protrudes from the fireplace opening plus the required 16" of hearth extension.

Figure 16

Leveling Bolt Installation

Two leveling bolts are included to level the insert if the fireplace has a stepped-up hearth. To install, raise the rear of the insert up and insert the leveling bolts into the holes in the rear corners of the insert. Adjust the bolts until they extend the same height as the hearth steps up. After the insert is installed, fine-tune the leveling bolts to level the insert (see Figure 17).

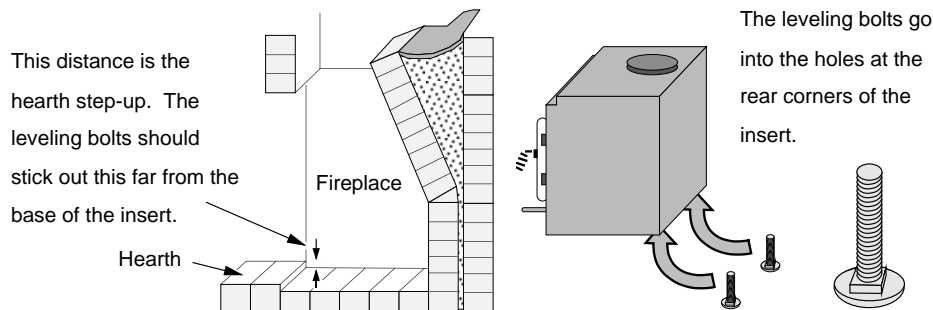
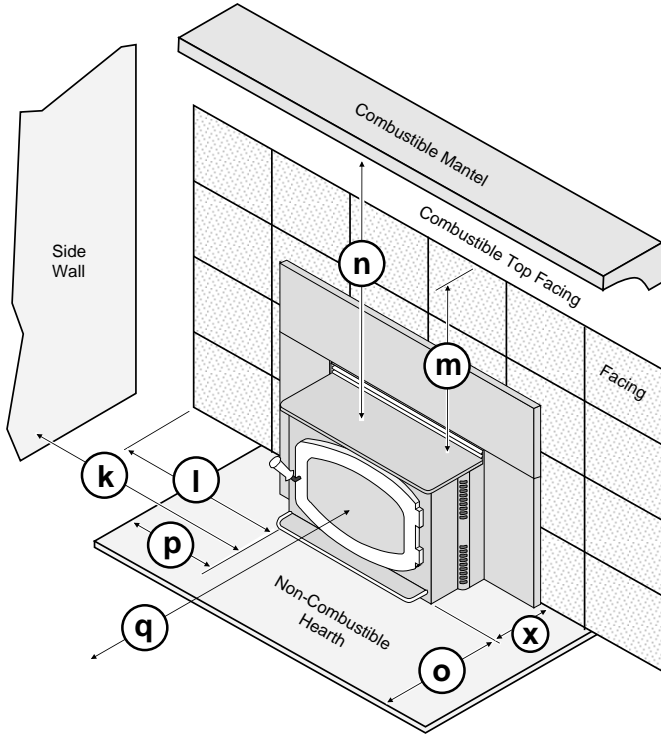

Figure 17

Insert Placement Requirements

- The insert must be placed so that no combustibles are within, or can swing within (e.g. drapes, doors), 36" of the front of the insert
- Insert and hearth must be installed on a level, secure floor
- The minimum clearances, facing, and hearth requirements in Figure 18 must be met.



Minimum Clearances

	Standard Model	Cook-Top Model
k Sidewall to Insert	15"	15"
l Side Facing	13-1/2"	13-1/2"
m Top Facing	30"	31"
with Mantel Shield	17"	18"
n Mantel to Insert	32"	33"
with Mantel Shield	19"	20"
o Hearth (Front)*	16"	16"
p Hearth (Side)	8"	8"
q Front of Insert	36"	36"

x Extension onto Hearth 6-3/8" 8-7/8"

* Does not include the distance the insert extends onto the hearth (dimension "x").

Figure 18

Hearth Requirements

- Must extend 16" in front of the insert and 8" on both sides (min. 19" deep by 39-5/8" wide)
- Must be non-combustible and at least .018" thick (26 gauge)

Masonry Fireplace Requirements

- Chimney must have a clay tile liner or a stainless steel liner (positive connection)
- Entire fireplace, including chimney, must be clean and undamaged. Any damage must be repaired prior to installation of the insert
- Chimney height: 15' minimum; 33' maximum.
- Entire fireplace, including chimney, must meet local building requirements

Block-Off Plate Installation

Whenever this appliance is installed with a direct connection a block-off plate, or other non-combustible seal-off device (e.g. damper adapter), will need to be installed. This device is used to seal the chimney, insuring no smoke enters the home and providing the chimney system with a seal to promote draft. The directions below detail the steps for construction and installation of a block-off plate.

- Determine a location for the block-off plate at the top of the firebox below the damper area (make it high enough to allow installation of the connection pipe). The location should be level and in an area where it can be mounted easily. Measure the width at the rear ("A") and front ("B") of the firebox at the height where the block-off plate will be installed (see Figure 19). Then measure the depth of the location where the block-off plate will be installed ("C").
- Make a cardboard template of the measurements, but add a 2" flange to each side. This flange will be used to mount the block-off plate to the inside of the firebox. Bend the flanges downwards on the template and place it inside the fireplace. If the template fits correctly in its planned location, go to the next step. If it does not, make a new template with the appropriate corrections until it fits correctly.
- With the template in place, mark the location of the flue (see "Dimensions" on page 6). This location approximates the center of the flue when the insert is in place (a slight offset may occur based upon insert and block-off plate placement). Remove the template and cut a 6 1/4" diameter hole centered on this mark.
- Make the block-off plate of 24 gage or thicker steel to match the template. Drill two holes in each flange for mounting the plate.
- Mount the block-off plate using masonry screws.
- Insulate the block-off plate using high-temperature fiberglass insulation (Kaowool® or equivalent) and furnace cement (allow the cement to dry for at least 24 hours before burning).
- After placing the appliance and installing the pipe through the block-off plate, use high-temperature fiberglass insulation and furnace cement to seal any cracks between the pipe and block-off plate.

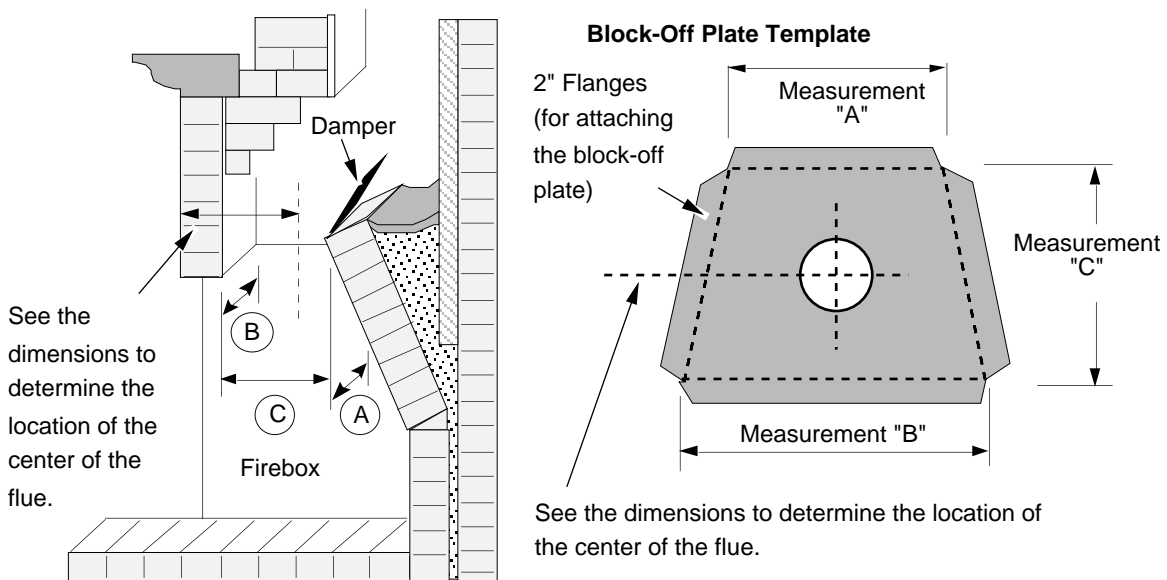

Figure 19

Insert with Positive Connection

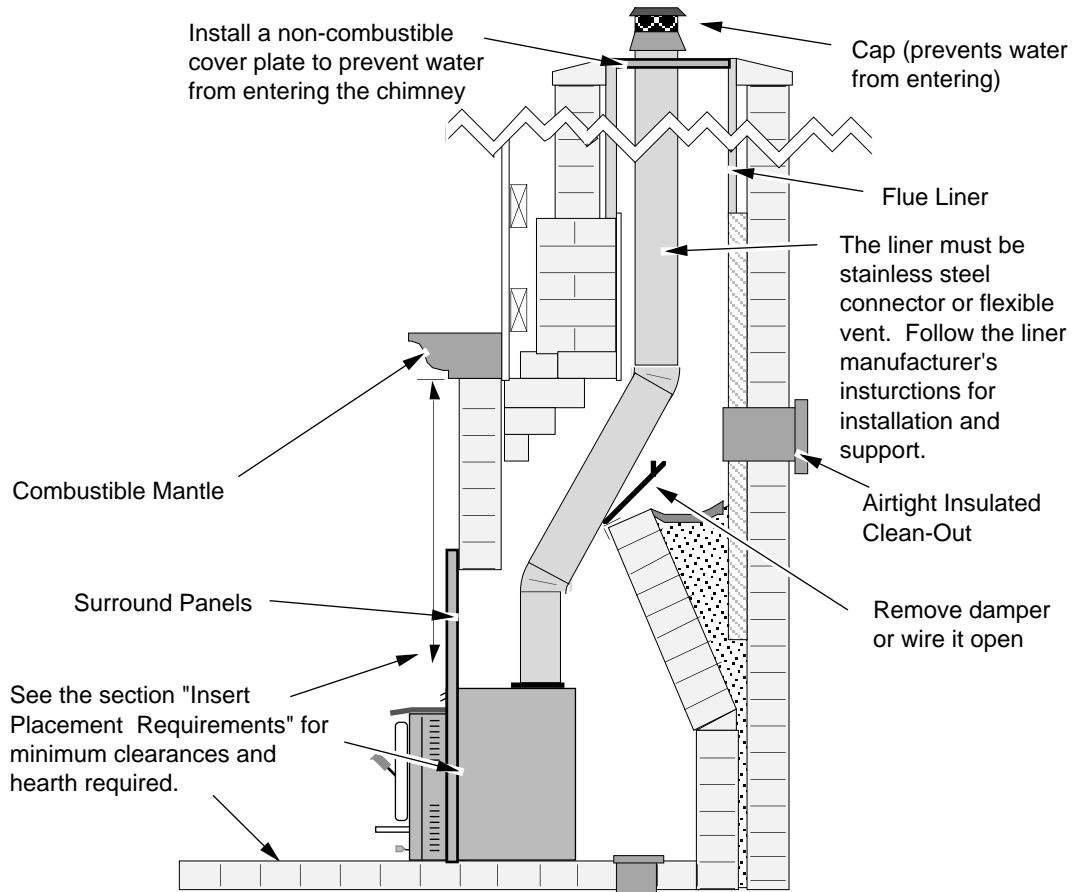
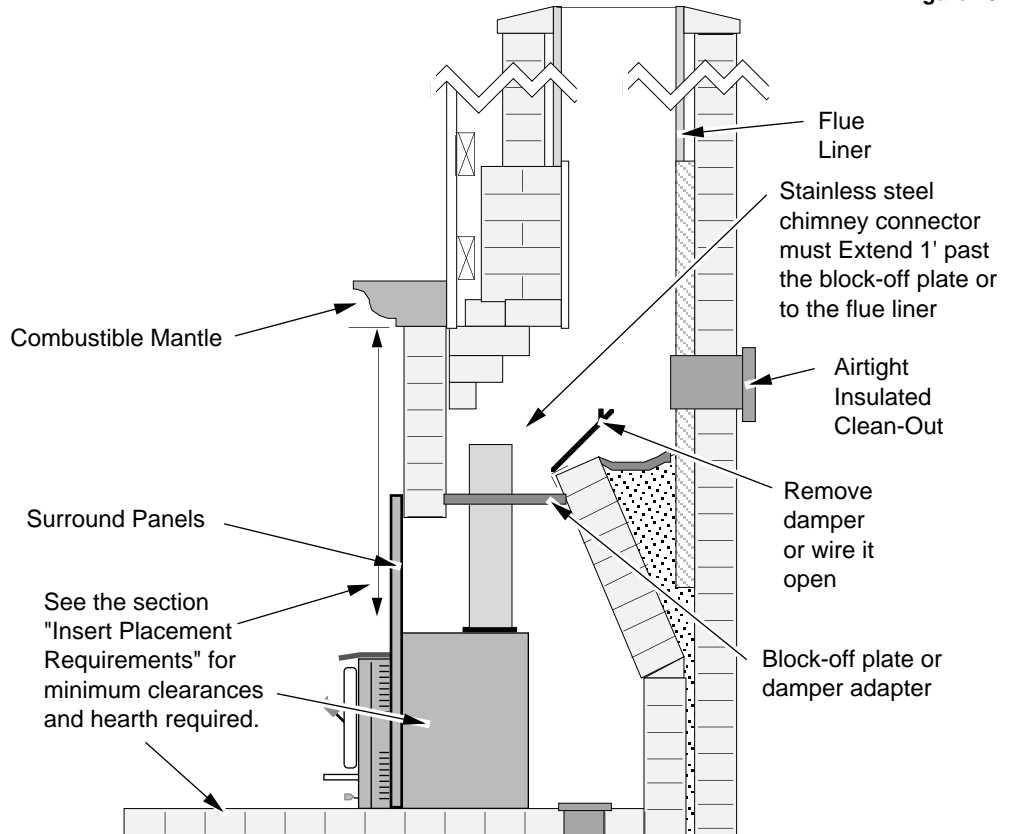

Figure 20

Insert with Direct Connection (Masonry Fireplace)

NOTE:

Direct connections require installation of an airtight block-off plate or damper adapter (see "Block-off Plate Installation" on page 21).



Insert with Face Seal Connection

NOTE:

Face seal connections require installation of the surround panels and insulation (see the "Surround Panel Installation" on page 46).

NOTE: This installation may be used with a masonry fireplace only. The requirements in the section "Masonry Fireplace Requirements" must be fulfilled prior to installation.

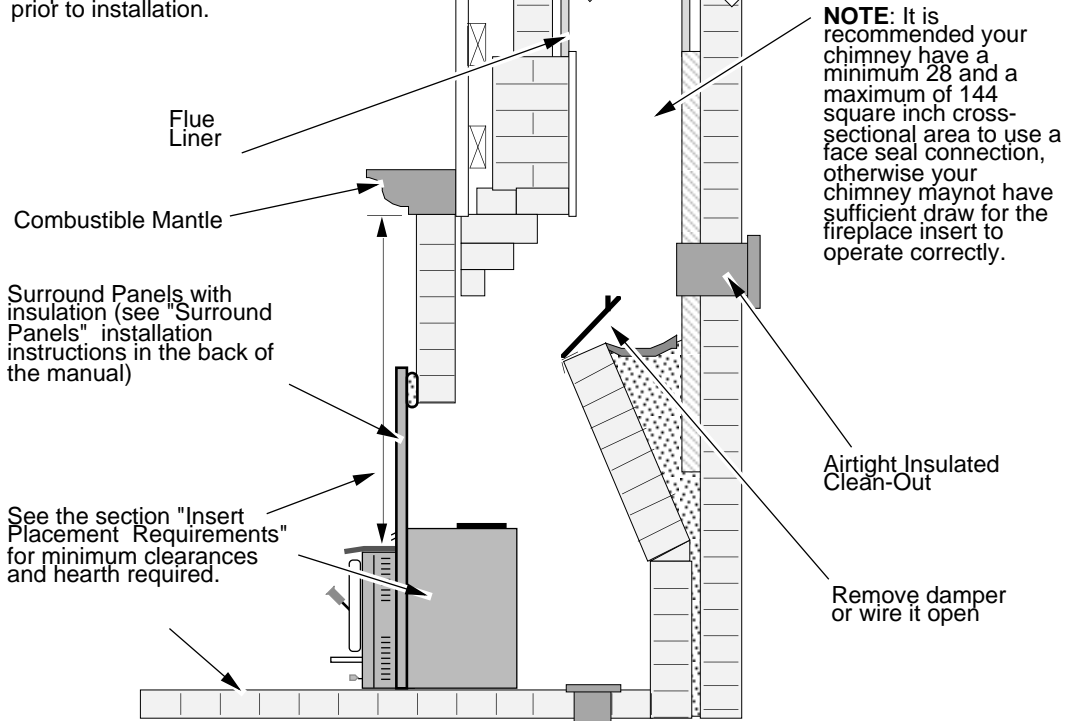

NOTE: It is recommended your chimney have a minimum 28 and a maximum of 144 square inch cross-sectional area to use a face seal connection, otherwise your chimney may not have sufficient draw for the fireplace insert to operate correctly.

See the section "Insert Placement Requirements" for minimum clearances and hearth required.

See the section "Surround Panels with insulation" installation instructions in the back of the manual)

Safety Notice



If this appliance is not properly installed, a house fire may result. For your safety, follow the installation directions. Contact local building or fire officials about restrictions and installation inspection requirements in your area.



Read and follow all of the warnings on pages 4 and 5 of this manual.

Before Your First Fire

Verify the Installation

Before starting the stove, verify that the stove is properly installed and all of the requirements in this manual have been followed.



Keep all flammable materials 36" away from the front of the stove (drapes, furniture, clothing, etc.).

Curing the Paint

Follow the steps below to cure the paint (first fire):

- Open doors and windows in the room to ventilate the heater during the curing process.
- Vacate the room. The fumes from the initial heating process are non-toxic but may be unpleasant.
- Slowly bring the heater to a medium burn (400°F/204°C) for 45 minutes. Then increase the burn temperature to a hot burn (600°F/315°C) for an additional 45 minutes. This will cure the paint.

Door Gasket - The door gasket might adhere to the paint on the front of the heater. Leave the door slightly ajar for the first fire and be careful when opening the door after the first fire.

2 to 4 hours

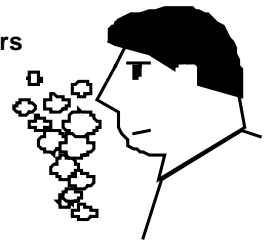

Carbon Monoxide (CO) Emissions

Smoke from wood heaters contain CO. This gas is an indication of incomplete combustion and is detrimental to the environment and to your health. The more visible the smoke, the higher the CO levels. Burning dry wood is the most significant step you can take to reduce CO emissions. It is also important to understand the combustion process so you can burn your heater efficiently. Read the manual thoroughly so that you can operate your heater in the most efficient and clean manner possible.

Over-Firing the Stove

DO NOT OVERFIRE THIS HEATER: Attempts to achieve heat output rates that exceed heater design specifications can result in permanent damage to the heater.

This stove was designed to operate at a high temperature. But due to differences in vent configuration, fuel, and draft, this appliance can be operated at an excessive temperature. If the stove top or other area starts to glow red, you are over-firing the stove. Shut the air control down to low and allow the stove to cool before proceeding.



Over-firing may lead to damage of plated surfaces. If you are uncertain of over-firing conditions, we suggest placing a stove thermometer (e.g. Rutland® Model 710) directly over the door on the stove top - temperatures exceeding 800° are generally considered over-firing and will void the warranty.

Opening the Door

Turn the handle clockwise to un-latch.

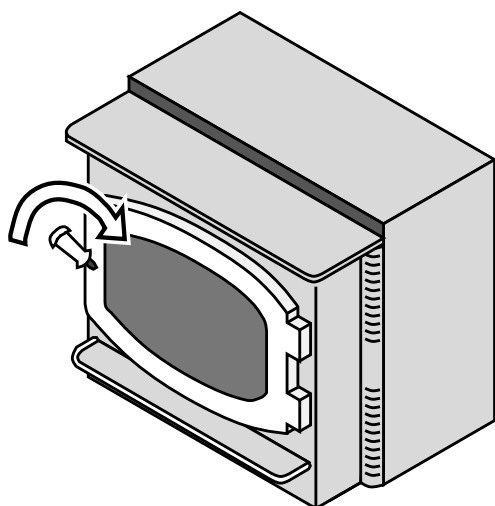

Swing the door open.

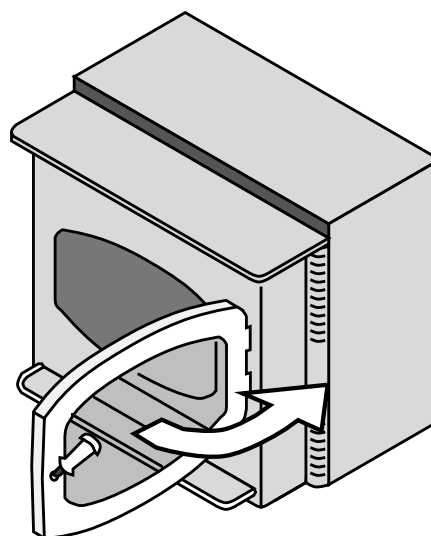

The door becomes hot during use. Use a glove to open the door if the handle is hot.



To prevent smoke from entering the room, open the bypass before opening the door (see following page for directions). You can also open the door a small amount and let air enter the firebox.

Bypass Operation

The bypass controls the flow of smoke inside the heater. When pulled out, smoke goes directly up the flue, creating more draft. When pushed in, the smoke goes around the baffle, utilizing the secondary combustion and making the heater more efficient.

- When starting or re-loading, pull the bypass out.
- During normal operation, push the bypass in.

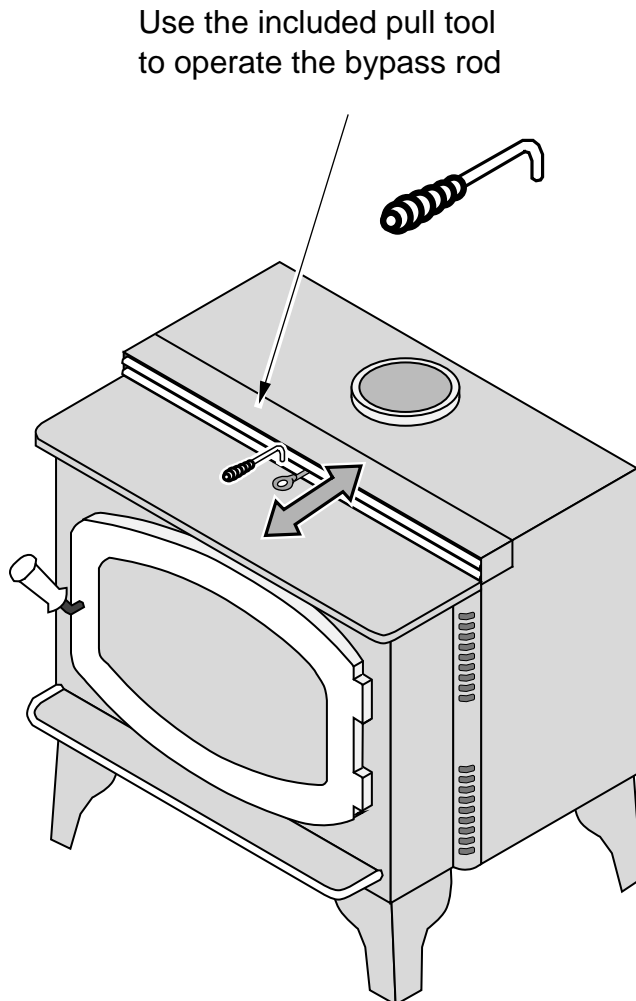

Bypass Pulled Out

Used for starting and re-loading

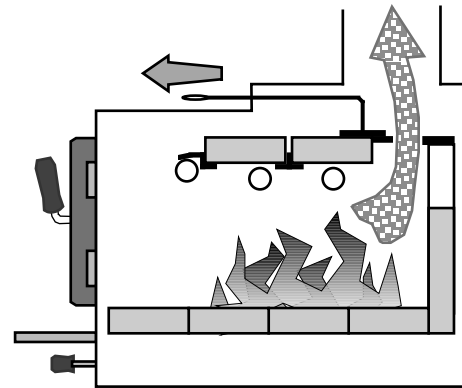

Bypass Pushed In

Used for normal operation

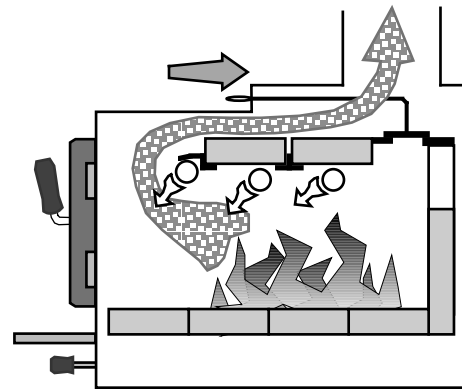

Starting a Fire

Since the dawn of time man has debated the best way to start a fire. Some use the boy-scout "tee-pee", some prefer the "tic-tac-toe" stack. Either way, review the hints and warnings below to ensure proper fire starting.

- Make sure the air control is pushed in. If additional air is needed, open the doors 1/4" during the first five minutes of start-up. The bypass may be opened if the heater needs more draft.

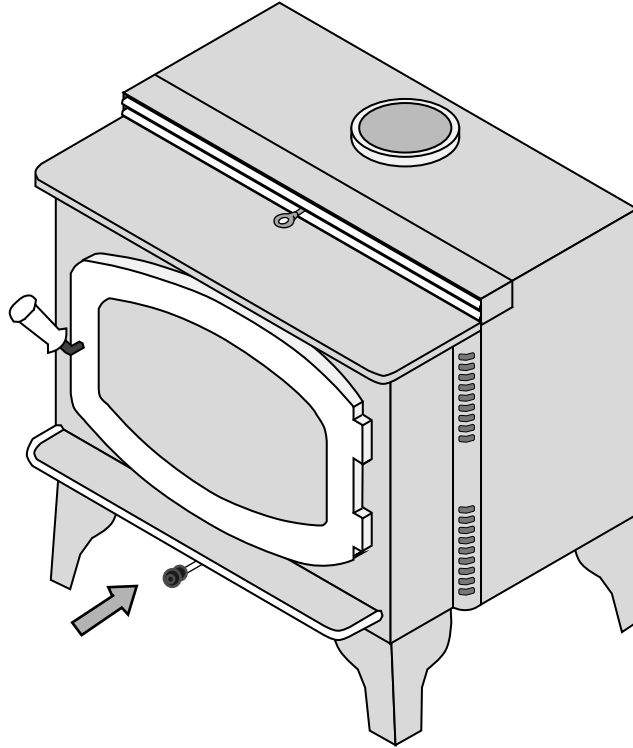

Never use gasoline, gasoline-type lantern fuel, kerosene, charcoal lighter fluid, or similar liquids to start or "freshen up" a fire in this stove. Keep all such liquids well away from the stove while it is in use.



If using a firestarter, use only products specifically designed for stoves - follow the manufacturer's instructions carefully.



If the smoke does not pass up the chimney, ball up one sheet of newspaper, place it in the center of the firebox and light it. This should start the chimney drafting (this eliminates "cold air blockage").



Use plenty of kindling to ensure the stove reaches a proper temperature. Once the kindling is burning rapidly, place a few larger pieces of wood onto the fire.

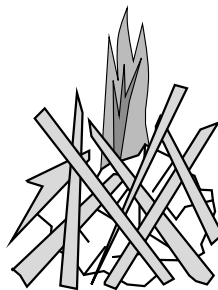

Adjusting the Burn Rate

Use the air control slider to control the burn rate of the stove. See the illustration below for details.

Use the air control to change the burn rate.

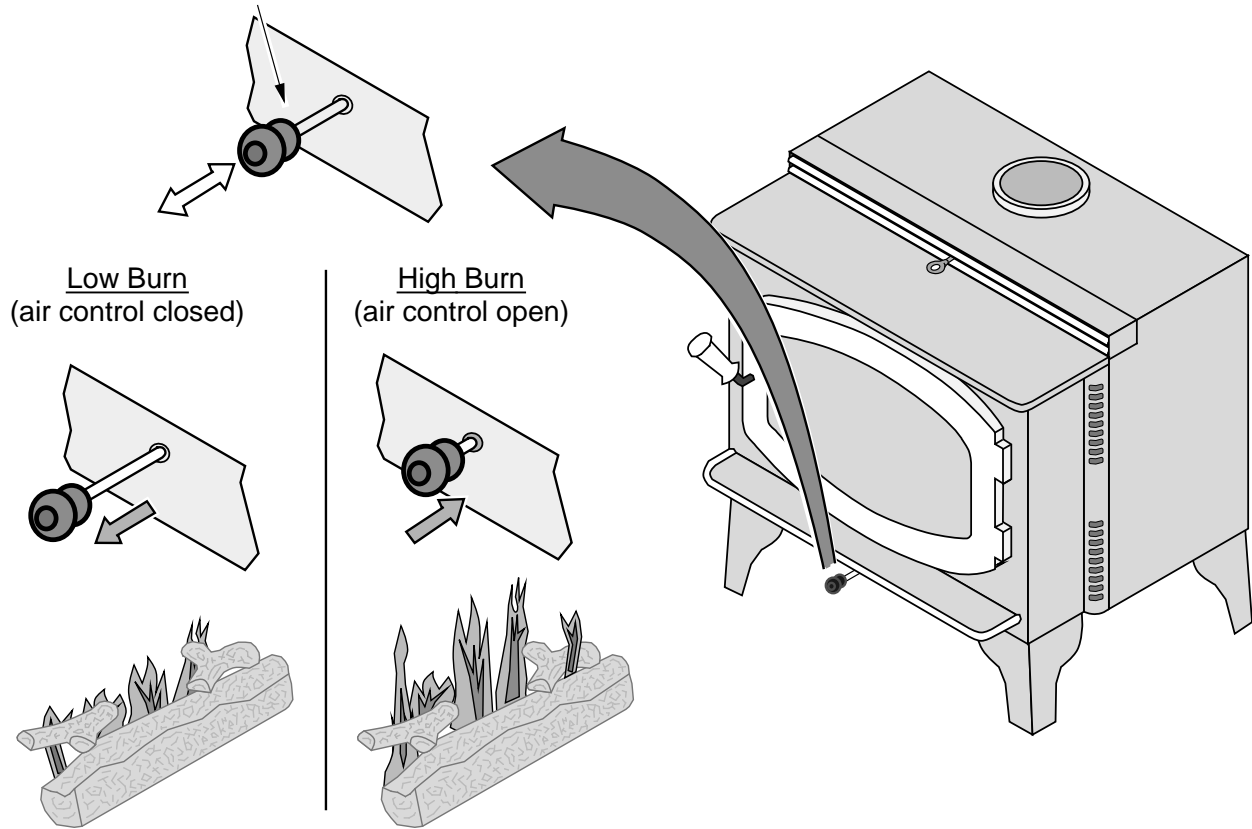

Approximate Air Control Settings

Overnight Burn	Fully out to 9/32" open
Medium Burn	9/32" to 5/16" open
Medium High Burn	5/16" to 7/16" open
High Burn	7/16" open to pushed fully in



The air control becomes hot during operation - use gloves or a tool to prevent burns.



The air control may take several minutes to influence the burn rate. When making adjustments, you may wish to let the stove burn for 10 minutes to gauge performance.

Understanding Your Heater's Combustion System

This heater uses a dual combustion system detailed below:

Primary Combustion: This is the combustion (fire) that takes place directly on the wood. Primary combustion determines how fast the fire burns. Air for primary combustion is supplied through the air control. When you adjust the air control you control the amount of air that reaches the fire and creates primary combustion. The air control supplies air to the air wash (the air holes above the door opening – used to help clean the glass) and through the pilot orifice (center bottom of the door opening). By using the air control, and supplying air through these two openings, you control primary combustion.

Secondary Combustion: This is the combustion (fire) that does not contact the wood. Secondary combustion burns the visible emissions or smoke that is not consumed during primary combustion. During some phases of combustion you will see secondary combustion. It appears as a glowing flame at the top of the firebox. Air for secondary combustion is supplied by the air tubes at the top of the firebox.

Items to Consider:

- During medium and high burn rates the stove will manage secondary and primary combustion on its own. When the heater is set to a low burn rate more care is needed to ensure the secondary combustion system works properly. Make sure the stove is hot and a good coal bed is established before adjusting your heater to low burn.
- Understanding the combustion system in this heater will help minimize the visible emissions this heater releases into the environment. The primary pilot orifice at the center bottom of the door opening is designed to help the secondary combustion at low burn settings. The pilot provides a small amount of air that burns up through the fuel load providing the heat and flame needed for the secondary system to ignite. The air tubes under the baffle need to remain ignited for low burns to be effective.
- As you load your heater for a low burn, take care in placing the wood. This will affect how well your secondary system works as the wood is consumed. Do not block the pilot orifice. Stack wood so the pilot air can burn its way up between the pieces, helping your heater burn effectively throughout the low fire. This will reduce the visible emissions your heater produces and increase the amount of heat you get from the wood. If you are unsure how well your heater is burning look at the chimney cap to monitor visible emissions.

Burning Your Heater

Starting a Fire: When starting a fire it is imperative to get the heater hot and drafting as quickly as possible. This promotes combustion and reduces emissions. There are many ways to start a fire and you will become adept as you become familiar with the way your heater burns. Before you start, make sure your burn rate setting (air control) is all the way open and the by-pass (if equipped) is open. We suggest that you use a layer of crumpled newspaper covered with a three layers of small kindling, stacked tic tac toe style with approximately ½"-1" gaps between them. Continue to layer wood on top of the kindling with the same air gaps using slightly bigger pieces increasing in size as you stack upward with the final layer being 3-5" diameter pieces loaded on the top. This should fill the firebox. Light the newspaper in several places near the door opening. Shut the door but do not latch it, creating a small opening to allow air to feed the kindling fire. Never leave your heater unattended if your door is not latched shut. While the kindling burns the fire will heat and ignite the larger pieces above. Once the whole load is burning shut and latch the door leaving the burn rate on high. Depending on your heater, the chimney, and the outside environment, you may need to leave your bypass open for up to 20 minutes after lighting the fire. If the fire dies when you shut the bypass you will need to leave it open longer. The presence of a hot coalbed is critical to good combustion. We cannot overstate the importance of a hot coal bed before slowing your burn rate or re-loading your heater. We recommend that you allow the first ignition load of wood to burn through at the high burn rate. This will get your heater up to temperature and establish a coal bed.

Reloading: When reloading a hot heater set the burn rate on high for at least 15 min before slowing it down.

Low Burn: If preparing for an overnight or low burn a longer heat up period may be necessary. Reload the heater full of wood making sure there are air gaps between the wood pieces so the pilot air can burn up through the middle load keeping the secondary combustion system hot and active throughout the burn. After loading, burn the heater on high for at least 15 minutes before setting the air control to low. Excessive creosote buildup (or sooting) in the heater at the end of a low burn signifies that the heater was not hot enough and the wood load was not burned long enough on high after loading before shutting down the air control.

Optional Blower Operation

The blower will turn on once the stove is up to temperature. This is typically 15 to 30 minutes after starting the fire. Follow the directions below to alter the blower speed.

OFF

Turn the dial all the way counter-clockwise until it clicks off.

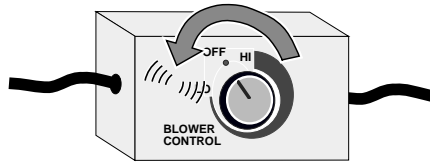

HIGH

The high position is all the way counter-clockwise, **without** clicking off.

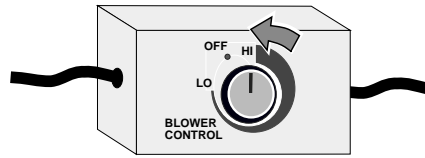

LOW

Turn the dial all the way clockwise.

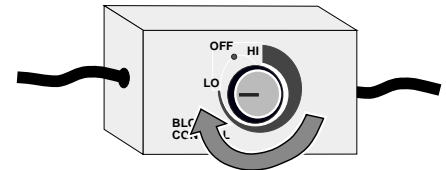

The blower may be used to affect heat output (i.e.: to reduce heat output, turn the blower down).



Route the power cord in a location where it will not come in contact with the appliance or become hot.

Re-Loading the Stove

Follow the directions below to minimize smoke spillage while re-loading the stove.

1. Open the air control all the way (push it in). Open the bypass (pull it out).
2. Open the door slightly. Let the airflow inside the firebox to stabilize before opening the door fully.
3. Load wood onto the fire.

Overnight Burn

This stove is large enough to accommodate burn times up to eight hours. Follow the steps below to achieve an overnight burn.

1. Move the air control to high burn and let the stove become hot (burn for approximately 15 minutes).
2. Load as much wood as possible. Use large pieces if possible.
3. Let the stove burn on high for 15 minutes to keep the stove hot, then turn the air control to low.
4. In the morning the stove should still be hot, with embers in the coal bed. Stir the coals and load small pieces of wood to re-ignite the fire, if desired.



Differences in chimney height and draft may lower overall burn times.

Normal Operating Sounds

Creaks and Clicks:

The 3/16" and 1/4" steel may creak or click when the stove heats up and cools down - this is normal.

Blower Sounds:

The blower will make a slight "hum" as it pushes air through the stove.

Hint:

Make sure the leveling bolts on legs are extended - preventing the hearth from amplifying any vibrations.

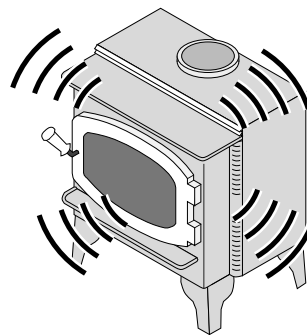

Hints for Burning

- Get the appliance hot before adjusting to low burn
- Use smaller pieces of wood during start-up and high burns to increase temperature
- Use larger pieces of wood for overnight or sustained burns
- Stack the wood tightly together to establish a longer burn
- Be considerate of neighbors & the environment: burn dry wood only
- Burn small, intense fires instead of large, slow burning fires when possible
- Learn your appliance's operating characteristics to obtain optimum performance

Selecting Wood

- Dry Wood is Key
- Dry wood burns hot, emits less smoke and creates less creosote.
- Testing Wood Moisture
- Split wood stored in a dry area will be fully dry within a year. This insures dry wood. If purchasing wood for immediate use, test the wood with a moisture meter. Some experienced wood burners can measure wood moisture by knocking pieces together and listening for a clear "knock" and not a "thud".

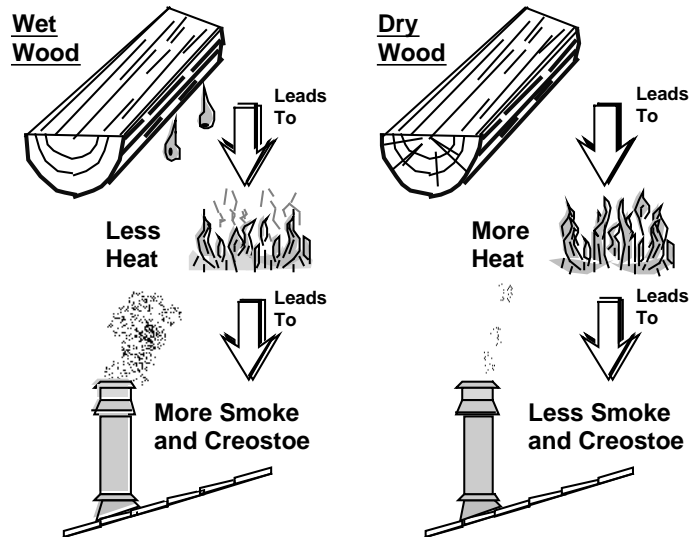

Why Dry Wood is Key

Wet wood, when burned, must release water stored within the wood. This cools the fire, creates creosote, and hampers a complete burn. Ask any experienced wood burner and he or she will agree: dry wood is crucial to good performance.

Wood Cutting and Storage

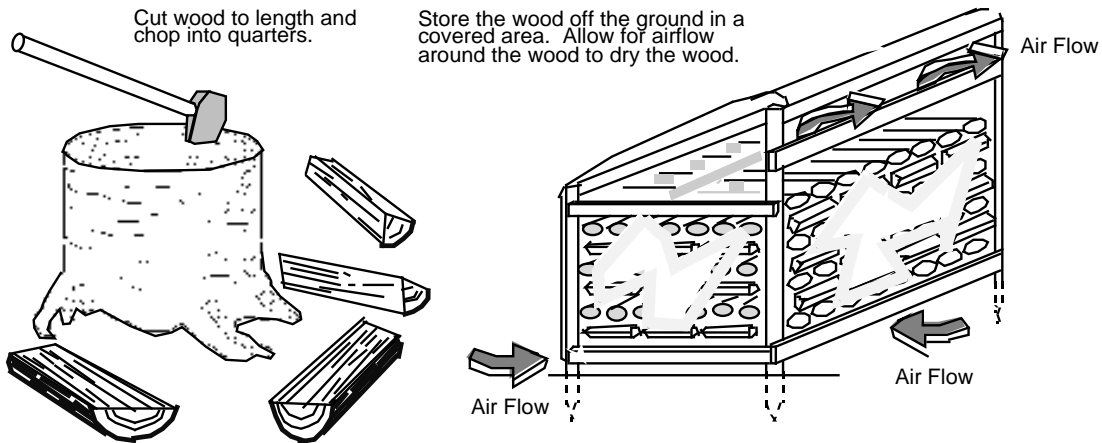

Do Not Burn List

This heater is designed to burn natural wood only. Higher efficiencies and lower emissions generally result when burning air dried seasoned hardwoods, as compared to softwoods or to green or freshly cut hardwoods. **DO NOT BURN:**

- (1) Garbage;
- (2) Lawn clippings or yard waste;
- (3) Materials containing rubber, including tires;
- (4) Materials containing plastic;
- (5) Waste petroleum products, paints or paint thinners, or asphalt products;
- (6) Materials containing asbestos;
- (7) Construction or demolition debris;
- (8) Railroad ties or pressure-treated wood;
- (9) Manure or animal remains;
- (10) Salt water driftwood or other previously salt water saturated materials;
- (11) Unseasoned wood; or
- (12) Paper products, cardboard, plywood, or particleboard. The prohibition against burning these materials does not prohibit the use of fire starters made from paper, cardboard, saw dust, wax and similar substances for the purpose of starting a fire in an affected wood heater.

Burning these materials may result in release of toxic fumes or render the heater ineffective and cause smoke.

Troubleshooting

Problem	Possible Cause
Smoke Enters Room During Start-Up	<ul style="list-style-type: none"> • Open the bypass (pg. 26). • Open the air control (pg. 28). • Cold Air Blockage - burn a piece of newspaper to establish a draft. • If the flame is not getting enough air, a small crack in the door is all that is needed.
Kindling Does Not Start - Fire Smolders	<ul style="list-style-type: none"> • Open the bypass (pg. 26). • Open the air control (pg. 28). • Not enough starter paper - use additional newspaper if necessary. • If the flame is not getting enough air, a small crack in the door is all that is needed.
Smoke Enters Room While Re-Loading	<ul style="list-style-type: none"> • Open the bypass (pg. 26) before opening the door. • Let the air stabilize before fully opening the door. Then open the door approximately 1 inch. Let air go into the firebox for a few seconds. Once the smoke appears to be flowing up the chimney consistently, open the door. • Insufficient Draft - Chimney height and outside conditions can negatively affect draft. In these cases a small amount of smoke may enter the home. Adding more pipe or a draft-inducing cap may help.
Stove Does Not Burn Hot Enough	<ul style="list-style-type: none"> • Wood is Wet - see the section "Selecting Wood" on page 31 for details on wood. • Make sure the air control is all the way open. Slide the control back and forth to insure the control is not stuck. • Insufficient Draft - Chimney height and outside conditions can negatively affect draft. In these cases the fire may burn slowly. Adding more pipe or a draft-inducing cap may help.
Blower Does Not Run	<ul style="list-style-type: none"> • Stove is Not Up to Temperature - This is normal. The blower will come on when the stove is hot - usually 15 to 30 minutes. • Electricity is Cut to the Blower - Check the household breaker or fuse to make sure it is operable.
Stove Does Not Burn Long Enough	<ul style="list-style-type: none"> • Depending upon wood, draft, and other factors, the burn time may be shorter than stated. Make sure the doors are sealing and not allowing air into the firebox - See the section "Door and Glass Inspection" on page 35 for details. • Check the ash bed for coals. Often, coals are still glowing under a slight bed of flyash. By raking these into a pile you can re-start your stove quickly.



Failure to properly maintain and inspect your appliance may reduce the performance and life of the appliance, void your warranty, and create a fire hazard.

Daily Maintenance (while stove is in use)

Remove Ash (if necessary)

Whenever ashes get 3 to 4 inches deep in your firebox or ash pan, and when the fire has burned down and cooled, remove excess ashes. Leave an ash bed approximately 1 inch deep on the firebox bottom to help maintain a hot charcoal bed. Let the stove cool completely before removing ashes (wait at least two hours after the last coal has extinguished). Ashes should be placed in a metal container with a tight-fitting lid. The closed container of ashes should be placed on a noncombustible floor or on the ground, away from all combustible materials, pending final disposal. The ashes should be retained in the closed container until all cinders have thoroughly cooled.

- Follow the directions below to remove ash.
1. Let the stove cool completely (at least two hours after the last coal has extinguished).
 2. Place a cloth or cardboard protector over the hearth to catch ash and protect against scratching.
 3. Open the doors and scoop the ash into a metal container with a tight fitting lid. The closed container of ashes should be placed on a noncombustible floor or on the ground, away from all combustible materials, pending final disposal.

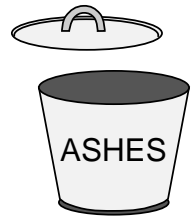

Improperly disposed ashes lead to fires. Hot ashes placed in cardboard boxes, dumped in back yards, or stored in garages, are recipes for disaster.



Wood-burning stoves are inherently dirty. During cleaning have a vacuum ready to catch spilled ash (make sure ash is entirely extinguished).



There are vacuum cleaners specifically made to remove ash (even if the ash is warm). Contact your dealer for details.

Clean the Glass (if necessary)

This appliance has an airwash to keep the glass clean. However, burning unseasoned wood or burning on lower burn rates leads to dirtier glass (especially on the sides). Clean the glass by following the directions below.

Allow the stove to fully cool. Apply glass cleaner or soapy water to the inside of the glass. Wipe with newspaper or a paper towel.



For Stubborn Creosote:

Dip newspaper or a paper towel in cool ashes and wipe it on the glass. The ash acts as a light abrasive.

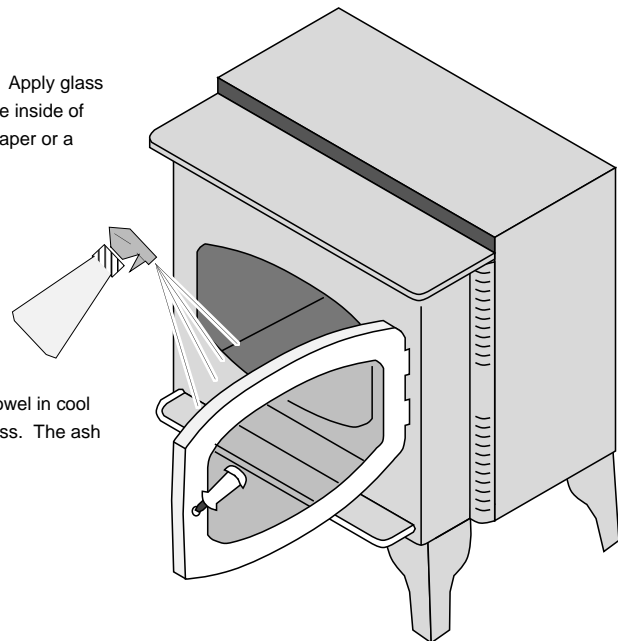

The glass will develop a very slight haze over time. This is normal and will not affect viewing of the fire.

Monthly Maintenance (while appliance is in use)



Make sure the appliance has fully cooled prior to conducting service.

Door and Glass Inspection

The door must form an air-tight seal to the firebox for the stove to work correctly. Inspect the door gasket to make sure it forms an air-tight seal to the firebox.



The door can be lifted off the hinges if extensive repairs are conducted.

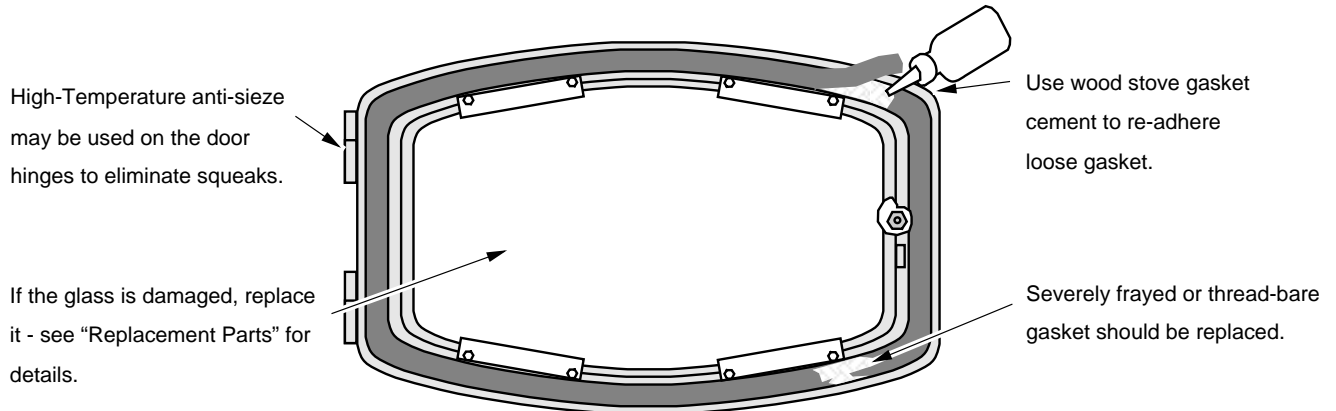

The door latch should pull the door against the face of the stove (but not so tight as to not allow full handle rotation). If the latch requires adjustment, follow the directions below.

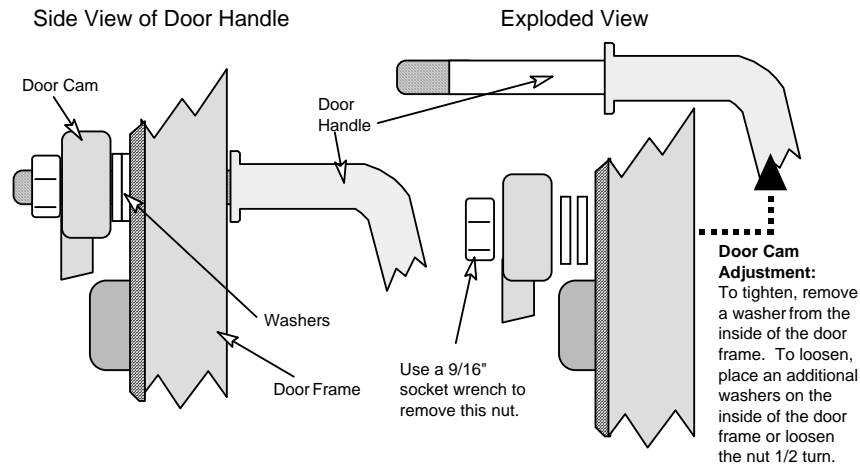

Creosote - Formation and Need for Removal

When wood is burned slowly, it produces tar and other organic vapors, which combine with expelled moisture to form creosote. The creosote vapors condense in the relatively cool chimney flue of a slow-burning fire. As a result, creosote residue accumulates on the flue lining. When ignited, this creosote makes an extremely hot fire. The chimney and chimney connector should be inspected at least once every two months during the heating season to determine if a creosote buildup has occurred. If creosote has accumulated, it should be removed to reduce the risk of a chimney fire.



If you are not certain of creosote inspection, contact your dealer or local chimney sweep for a full inspection. Excess creosote buildup may cause a chimney fire, that may result in property damage, injury, or death.

Yearly Maintenance



Make sure the appliance has fully cooled prior to conducting service.

Touch Up Paint

Included with the owner's pack of this appliance is a can of Stove-Brite® paint. To touch up nicks or dulled paint, apply the paint while the appliance is cool. Sand rusted or damaged areas before preparation (use 120 grit sandpaper). Clean and dry the area to prepare the surface. Wait at least one hour before starting the appliance. The touched up area will appear darker than the surrounding paint until it cures from heat. Curing will give off some fumes while curing – open windows to ventilate.

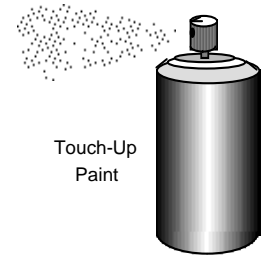

Cleaning the Air Duct and Blower (if applicable)

Use a vacuum to clean the air ducts (channels). This prevents dust from burning and creating odors. The optional blower should be vacuumed every year to remove any buildup of dust, lint, etc.

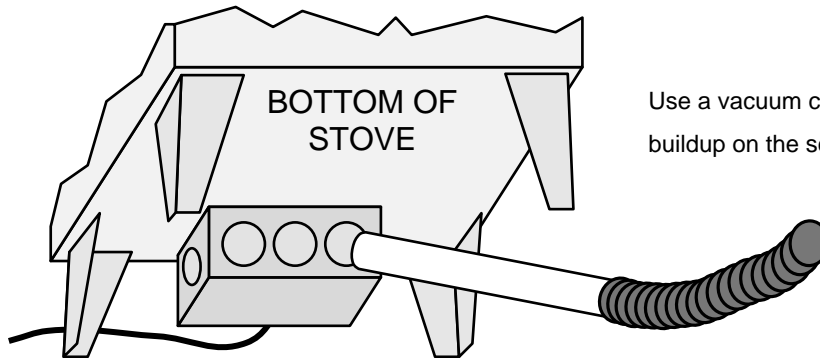

Use a vacuum cleaner to remove any buildup on the screens of the blower.

Firebrick and Baffle Inspection

Use the illustration on page 38 as a reference for checking the following items. Make sure the appliance is cool before proceeding.

Baffle Firebricks - check the bricks along the ceiling of the firebox to make sure they are intact and have no gaps between them. Slide the bricks to eliminate any gaps.

Baffle Supports - make sure the front and back baffle supports are in place and not degraded. Slight scaling or rusting of the metal is normal.

Secondary Air Tubes - Check the two air tubes and collars to make sure they are intact and not severely deteriorated. Slight scaling or rusting of the metal is normal. Make sure the push pins hold the air tubes in place.

Floor and Wall Firebricks - replace any severely damaged firebrick along the side or floor of the firebox.

Door Parts

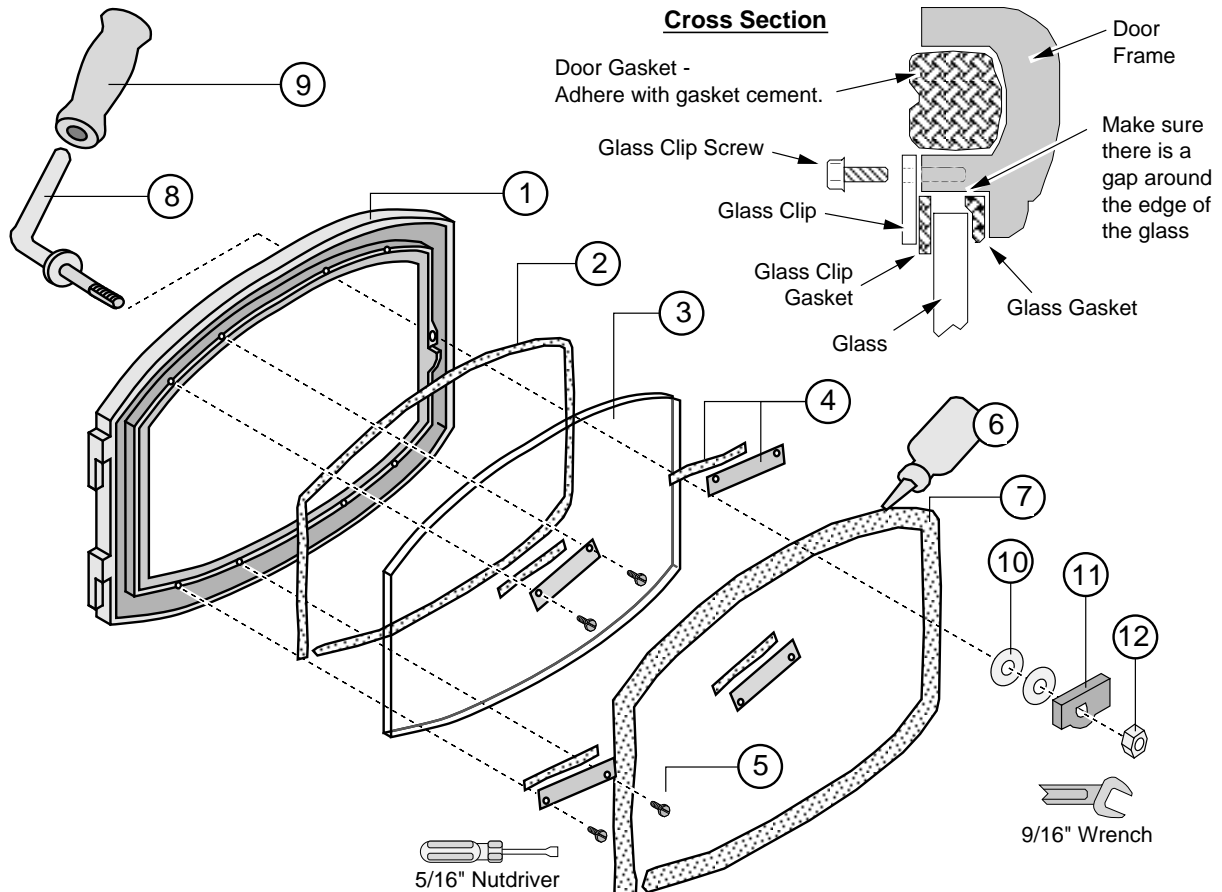

ID #	DESCRIPTION	QTY	PART #	ID #	DESCRIPTION	QTY	PART #
1	DOOR SHELL - BLACK Door Shell - Brass	1	99300505 99300502	2	GLASS GASKET - 3/8"	1	99900403
3	GLASS	1	99400302	4	GLASS CLIP WITH GASKET	4	91001250
5	GLASS CLIP SCREWS (10)	4	91001249	6	DOOR GASKET CEMENT	1	99900409
7	DOOR GASKET - 7/8" DIA.	1	99900406	8-12	DOOR HANDLE ASBLY.	1	99900415
9	DOOR HANDLE, WOOD	1	99300600	11	DOOR CAM, BRASS	1	99900416

Replacing the Glass



The glass must not contact the door shell or glass clips directly. The glass gasket and glass clip gaskets insulate the glass to prevent cracking. Do not over-tighten the glass clips.

Remove the door and place it on a suitable work surface. Remove the door gasket. Remove the glass clips (the glass clip gaskets adhere to the glass clips). Remove the glass. Place the glass gasket in the inner channel of the door shell then place the glass on top of the gasket. Replace the clips to secure.

Replacing the Door Gasket

The door gasket inserts into the outer groove of the door shell. Stove gasket cement holds it in place. Before installing, remove any residual cement. Lay the gasket in place (start at the lower left corner) and cut off any excess gasket (do not stretch the gasket. The cement fully cures with heat from the stove. You may need to open and close the door repeatedly to get the gasket to seat fully.

Replacing the Door Handle

See the illustration above for a component list (see pg. 35 for details on adjusting the door).

Firebox Parts

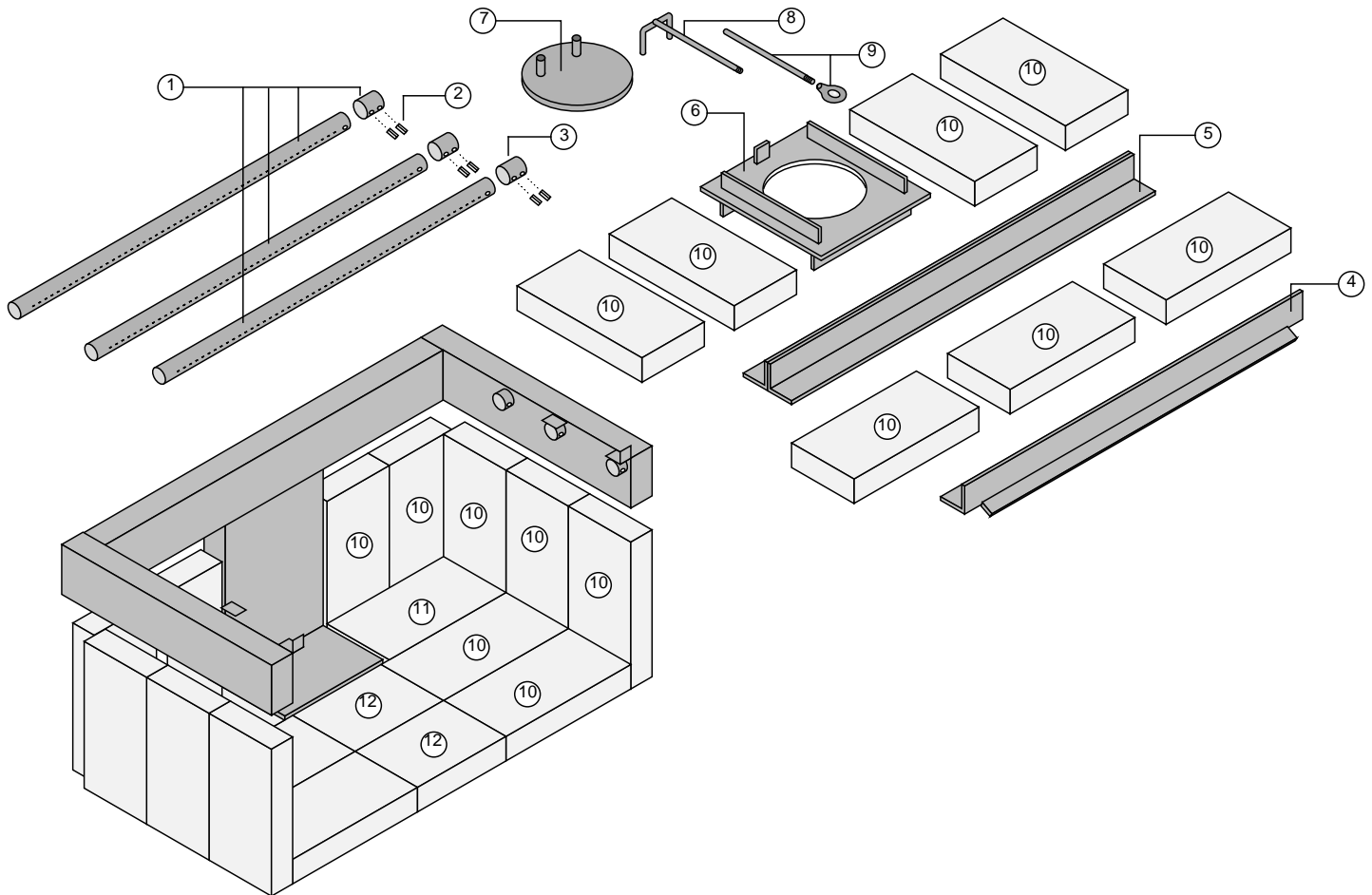

ID #	Description	Qty	Part #	ID #	Description	Qty	Part #
1	Air Tubes & Sleeve	1	98900210	2	Air Tube Roll Pins	6	98900357
3	Air Tube Retainer Sleeve	3	100-11001	4	Baffle Support, Front "Y"	1	99900277
5	Baffle Support, Rear "T"	1	99900278	6	Damper Plate	1	98900320
7	Damper Slider	1	98900338	8	Damper Yoke	1	98900326
9	Damper Extension Rod with Pull Ring	1	98900334	10	Brick - 9" x 4.5" un-cut	21	175-00001 (1) 99900102 (8)
11	Brick - Cut (8.25" x 4.5")	2	251-00010	12	Brick - Cut (6.25" x 4.5")	2	251-00011

Floor and Side Firebrick Removal & Replacement

Do not pry firebrick - they chip and crack easily. Remove the floor firebricks first. The side firebrick are removed later because they are pinned in place by the floor firebrick. Clean the firebox prior to replacing the firebrick.

Baffle Removal & Replacement



The baffle is held up by the front air tube. Make sure to support the baffle after removing the air tubes.

1. Lift up on the front portion of the front three firebricks.
2. Lift the front baffle support "Y" and rotate it forward until it can be removed.
3. Slide the center front firebrick forward and out the door opening. Then slide the side front firebricks towards the middle then out in the same manner.
4. Slide the center baffle support forward and out of the firebox.
5. Slide the rear firebrick forward and out of the firebox. **NOTE:** When the center rear firebrick are slid forward the damper plate will come to rest on the rear secondary air tube and rear air channel.
6. Slide the damper slider all the way forward.
7. Reach into the firebox and push up on the damper yoke until the damper yoke separates from the damper slider. Remove both the damper slider and damper plate by sliding them between the front two secondary air tubes.

REPLACEMENT INSTRUCTIONS:

1. Place the damper plate above the secondary air tubes in the rear center of the firebox.
2. Position the damper slider so the damper yoke inserts into the two tubes on the damper slider (make sure to have correct orientation). Then slide the damper slider over the damper plate until both are centered in the firebox.
3. Follow the instructions above in reverse order, starting with step number 5.

Air Tube Removal & Replacement

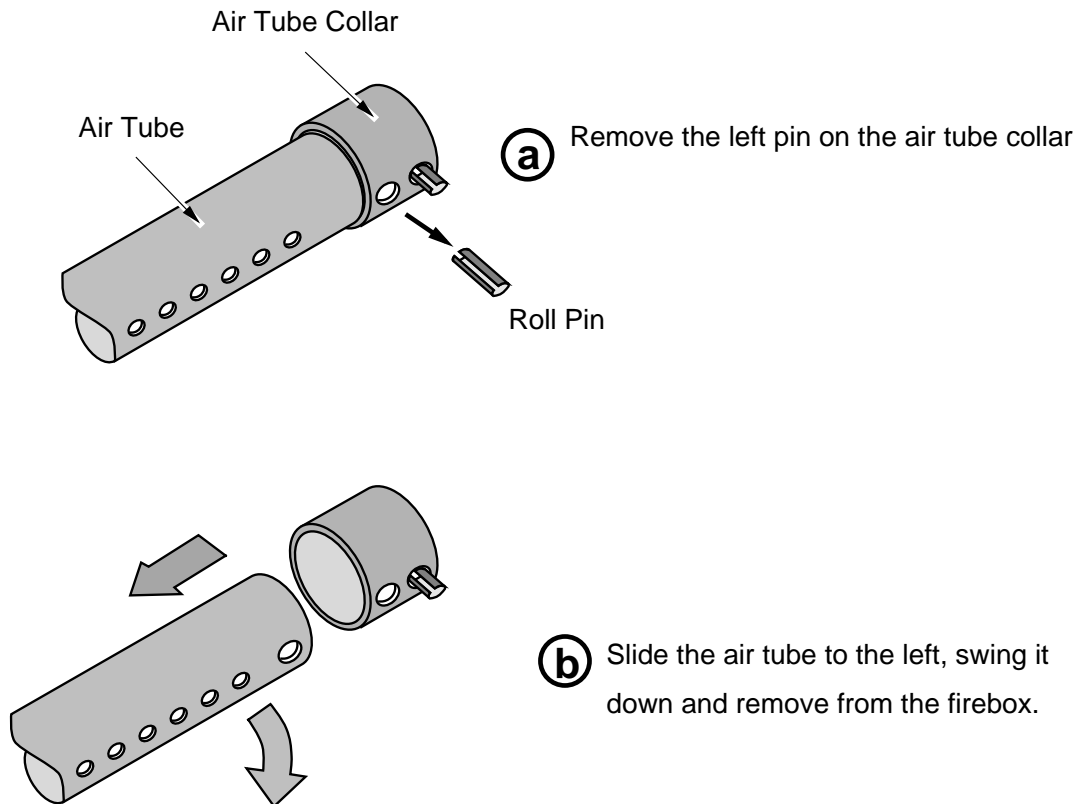

To register your TRAVIS INDUSTRIES, INC. 7 Year Warranty, complete the enclosed warranty card and mail it within **ten (10)** days of the appliance purchase date to: TRAVIS INDUSTRIES, INC., 12521 Harbour Reach Drive, Mukilteo, WA 98275. TRAVIS INDUSTRIES, INC. warrants this gas appliance (appliance is defined as the equipment manufactured by Travis Industries, Inc.) to be defect-free in material and workmanship to the original purchaser from the date of purchase as follows:

Check with your dealer in advance for any costs to you when arranging a warranty call.
Mileage or service charges are not covered by this warranty. This charge can vary from store to store.

Years 1 & 2 - COVERAGE: PARTS & LABOR

Firebox Assembly:

Firebox, Baffle Supports, Air Tubes, Air Channels, Convection Chamber

Door Assembly:

Solid Brass or Cast Door, Latch Assembly, Glass Retainers

Plated Finish

Plated Door, Legs, etc... See "Conditions & Exclusions" # 9 below.

Air Control Assembly

Slider Plate, Pressure Plate

Exclusions: Paint, Gasketing

Ceramic Glass

Glass (breakage from thermal shock)

Firebrick

Breakage from thermal shock

Accessories

Legs, Pedestal, Panels, Blower

Re-Installation Allowance

In cases where heater must be removed from home for repairs, a partial cost of re-installation is covered (pre-authorization required)

One-Way Freight Allowance

One-way freight allowance on pre-authorized repair done at factory is covered.

Years 3 Through 5 - COVERAGE: PARTS & LABOR

Firebox Assembly:

Firebox, Baffle Supports, Air Tubes, Air Channels, Convection Chamber

Air Control Assembly

Slider Plate, Pressure Plate

Exclusions: Paint, Gasketing, Plated Finish, Accessories (Legs, Pedestal, Panels, Blower), Glass, Firebrick, Re-Installation Allowance

Door Assembly:

Solid Brass or Cast Door, Latch Assembly, Glass Retainers

One-Way Freight Allowance

One-way freight allowance on pre-authorized repair done at factory is covered.

Years 6 & 7 - COVERAGE: PARTS ONLY

Firebox Assembly:

Firebox, Baffle Supports, Air Tubes, Air Channels, Convection Chamber

Door Assembly:

Solid Brass or Cast Door, Latch Assembly, Glass Retainers

Air Control Assembly

Slider Plate, Pressure Plate

Exclusions: Paint, Gasketing, Plated Finish, Accessories (Legs, Pedestal, Panels, Blower), Glass, Firebrick, Re-Installation Allowance, One-Way Freight Allowance, Labor

CONDITIONS & EXCLUSIONS

- This new appliance must be installed by a qualified installer. It must be installed, operated, and maintained at all times in accordance with the instructions in the Owner's Manual. Any alteration, willful abuse, accident, neglect, or misuse of the product shall nullify this warranty.
- This warranty is nontransferable, and is made to the ORIGINAL purchaser, provided that the purchase was made through an authorized Travis dealer.
- Discoloration and some minor expansion, contraction, or movement of certain parts and resulting noise, is normal and not a defect and, therefore, not covered under warranty. Over-firing (operation where the steel may glow red) of this appliance can cause serious damage and will nullify this warranty.
- The warranty, as outlined within this document, does not apply to the chimney components or other Non-Travis accessories used in conjunction with the installation of this product. If in doubt as to the extent of this warranty, contact your authorized Travis retailer before installation.
- Travis Industries will not be responsible for inadequate performance caused by environmental conditions such as nearby trees, buildings, roof tops, wind, hills or mountains or negative pressure or other influences from mechanical systems such as furnaces, fans, clothes dryers, etc.
- This Warranty is void if:
 - The unit has been operated in atmospheres contaminated by chlorine, fluorine or other damaging chemicals.
 - The unit is subject to submersion in water or prolonged periods of dampness or condensation.
 - Any damage to the unit, combustion chamber, heat exchanger or other components due to water, or weather damage which is the result of, but not limited to, improper chimney/venting installation.
- Exclusions to this 7 Year Warranty include: injury, loss of use, damage, failure to function due to accident, negligence, misuse, improper installation, alteration or adjustment of the manufacturer's settings of components, lack of proper and regular maintenance, damage incurred while the appliance is in transit, alteration, or act of God.
- This 7 Year warranty excludes damage caused by normal wear and tear, such as paint discoloration or chipping, worn or torn gasketing, chipped or cracked firebrick, etc. Also excluded is damage to the unit caused by abuse, improper installation, modification of the unit, or the use of fuel other than that for which the unit is configured (use cord wood only).
- Damage to brass or plated surfaces caused by fingerprints, scratches, melted items, or other external sources left on the surfaces from the use of abrasive cleaners is not covered in this warranty. Damage to the surfaces from over-firing (operation where the steel may glow red) is not covered in this warranty.
- TRAVIS INDUSTRIES, INC. is free of liability for any damages caused by the appliance, as well as inconvenience expenses and materials. Incidental or consequential damages are not covered by this warranty. In some states, the exclusion of incidental or consequential damage may not apply.
- This warranty does not cover any loss or damage incurred by the use or removal of any component or apparatus to or from the Travis appliance without the express written permission of TRAVIS INDUSTRIES, INC. and bearing a TRAVIS INDUSTRIES, INC. label of approval.
- Any statement or representation of Travis products and their performance contained in Travis advertising, packaging literature, or printed material is not part of this 7 year warranty.
- This warranty is automatically voided if the appliance's serial number has been removed or altered in any way. If the appliance is used for commercial purposes, it is excluded from this warranty.
- No dealer, distributor, or similar person has the authority to represent or warrant Travis products beyond the terms contained within this warranty. TRAVIS INDUSTRIES, INC. assumes no liability for such warranties or representations.
- Travis Industries will not cover the cost of the removal or re-installation of hearths, facing, mantels, venting or other components.
- If for any reason any section of this warranty is declared invalid, the balance of the warranty remains in effect and all other clauses shall remain in effect.
- This 7 year warranty is the only warranty supplied by Travis Industries, Inc., the manufacturer of the appliance. All other warranties, whether express or implied, are hereby expressly disclaimed and purchaser's recourse is expressly limited to the warranties set forth herein.

IF WARRANTY SERVICE IS NEEDED:

- If you discover a problem that you believe is covered by this warranty, you MUST REPORT it to your Travis dealer WITHIN 30 DAYS, giving them proof of purchase, the purchase date, and the model name and serial number.
- Travis Industries has the option of either repairing or replacing the defective component.
- If your dealer is unable to repair your appliance's defect, he may process a warranty claim through TRAVIS INDUSTRIES, INC., including the name of the dealership where you purchased the appliance, a copy of your receipt showing the date of the appliance's purchase, and the serial number on your appliance. At that time, you may be asked to ship your appliance, freight charges prepaid, to TRAVIS INDUSTRIES, INC. TRAVIS INDUSTRIES, INC., at its option, will repair or replace, free of charge, your appliance if it is found to be defective in material or workmanship within the time frame stated within this 7 year warranty. TRAVIS INDUSTRIES, INC. will return your appliance, freight charges (years 1 to 5) prepaid by TRAVIS INDUSTRIES, INC., to your regional distributor, or dealership.
- Check with your dealer in advance for any costs to you when arranging a warranty call. Mileage or service charges are not covered by this warranty. This charge can vary from store to store.

Listing Label

DO NOT REMOVE THIS LABEL

CONTACT LOCAL BUILDING OR FIRE OFFICIALS ABOUT INSTALLATION AND RESTRICTIONS IN YOUR AREA.
SUITABLE FOR USE IN CONVENTIONAL RESIDENTIAL INSTALLATIONS, MANUFACTURED HOMES AND ALCOVES.



MODEL:
OLYMPIC
Certified for USA and Canada



CONFORMS TO: UL STD 1482; CERTIFIED TO ULC STD S627-2000, ULC STD S628-1993

PREVENT HOUSE FIRES - Install and use only in accordance with the manufacturer's installation and operating instructions. Contact your local building or fire officials about restrictions and installation inspection in your area. Refer to local building codes and manufacturer's instructions for precautions required for passing a chimney through a combustible wall or ceiling. Do not run a chimney connector through a combustible wall or ceiling. Do not connect this unit to a chimney flue serving another appliance. Clearances may be reduced by methods specified in NFPA 211, listed wall shields, pipe shields, or other means approved by local building or fire officials.

FREESTANDING INSTALLATION

STANDARD RESIDENTIAL FREESTANDING INSTALLATIONS REQUIRE: 6" diameter, minimum 24 MSG black, with listed UL-103 HT factory-built chimney, suitable for use with solid fuels or masonry chimney. Pedestal or legs are required.

ALCOVE INSTALLATIONS REQUIRE: One of the Listed doublewall connectors listed below. Pedestal or legs are required.

MANUFACTURED HOME AND REDUCED CLEARANCE INSTALLATIONS REQUIRE: One of the Listed doublewall connectors listed below. In addition, manufactured home installations require outside air - use the optional pedestal or outside air boot.

- AMERI-TEC model DCC connector with model HS chimney
- DURA-VENT model DVL connector with DURA-PLUS chimney
- GSW-JAKES EVANS SUPERPIPE 2100
- I.C.C. EXCEL (103-HT) chimney with HP connector
- METALFAB model DW connector with TG chimney
- OLIVER MACLEOD PROVENT model PV connector with model 3103 chimney
- SECURITY model DP connector with SECURITY model ASHT or S2100 chimney
- SELKIRK METALBESTOS model DS connector with model SSII chimney
- OLYMPIA VENTIS® with Ventis doublewall black stove pipe

Minimum Clearances To Combustibles And Hearth Requirements:	Singlewall Connector Conventional Residential Installations	Alcove, Manufactured Home and Reduced Clearance Conventional Residential Installations
A.	16 in. / 407 mm	16 in. / 407 mm
B.	15 in. / 381 mm	10 in. / 254 mm
C.	9.5 in. / 242 mm	7.5 in. / 191 mm
D.	27.5 in. / 699 mm	27 in. / 686 mm
E.	17.5 in. / 445 mm	12 in. / 305 mm
F.	20.5 in. / 521 mm	18 in. / 458 mm
G.	US: 6 in. (153 mm) / CAN: 8 in. (204 mm)	US: 6 in. (153 mm) / CAN: 8 in. (204 mm)
H.	US: 16 in. (407 mm) / CAN: 18 in. (458 mm)	US: 16 in. (407 mm) / CAN: 18 in. (458 mm)

FREESTANDING CLEARANCE DIAGRAM	ALCOVE SPECIFICATIONS	FLOOR PROTECTION DIAGRAM
	Max. Alcove Depth: 48 in. Min. Alcove Height: See Owner's Manual Min. Alcove Width: See Owner's Manual	Floor protection must be a non-combustible material extending beneath the heater and to the front, sides and back as indicated. See Owner's Manual for examples of non-combustible materials that can be used. Do not obstruct space beneath heater.

FACTORY-BUILT (Z.C.) FIREPLACE OR MASONRY FIREPLACE INSTALLATION

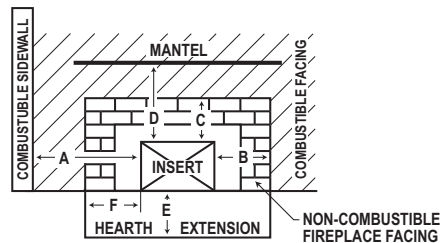

Minimum Clearance to Combustibles and Hearth Requirements	Standard Model	Cook Top Model
A.	15 in. / 381 mm	15 in. / 381 mm
B.	13.5 in. / 343 mm	13.5 in. / 343 mm
C.	30 in. / 762 mm	31 in. / 788 mm
With Shield	17 in. / 432 mm	18 in. / 458 mm
D.	32 in. / 813 mm	33 in. / 839 mm
With Shield	19 in. / 483 mm	20 in. / 508 mm
E. (US)	16 in. / 407 mm	16 in. / 407 mm
E. (Can)	18 in. / 458 mm	18 in. / 458 mm
F. (US)	6 in. / 153 mm	6.0 in. / 153 mm
F. (Can)	8 in. / 204 mm	8.0 in. / 204 mm

Factory-Built (Z.C.) Fireplace installations require a minimum 24" starter section directly connected to the fireplace chimney or a full re-line. Factory-Built (Z.C.) Fireplace chimney must have a minimum cross-sectional area of 28.85 square inches. The Factory-Built (Z.C.) Fireplace damper and control must be removed, or secured in the open position. For minimum Factory-Built (Z.C.) Fireplace firebox size, see manufacturer's installation instructions. Factory-Built (Z.C.) Fireplace floor protection must be 3/8" minimum non-combustible material or equivalent, extending 16" in front of insert and 8" to both sides. A metal deflector plate must be installed if the flue collar is not completely behind the Lintel plate of the Factory-Built (Z.C.) Fireplace openings.

Electrical Rating: 115V, 60 Hz., 1.8 Amps
 Optional Blower: SKU # 99000138, 99000190
 Do not route power cord under or in front of appliance.
 Replace glass only with 5mm neoceramic or ceramic glass.



Manufactured by:
TRAVIS INDUSTRIES, INC.
 12521 Harbour Reach Drive
 Mukilteo, WA 98275
 www.travisproducts.com

U.S. ENVIRONMENTAL PROTECTION AGENCY
 Certified to comply with 2015 particulate emission standards. Not approved for sale after May 15, 2020. 2.6 g/h, Method 28, 5H, 2015

DATE OF MANUFACTURE

2015	2016	2017	2018	Jan	Feb	Mar	Apr	May	Jun	Jul	Aug	Sep	Oct	Nov	Dec
------	------	------	------	-----	-----	-----	-----	-----	-----	-----	-----	-----	-----	-----	-----

Made in U.S.A.

0914

Stove Leg Installation (Brass # 99200500, Cast Black # 99200800, Sculptured # 99200105)

Raise the stove 8" (use lumber). Attach each leg following the instructions below.

Attach each leg to the stove by inserting a bolt and washer through the hole or slot in the leg and into the threaded hole on the stove.

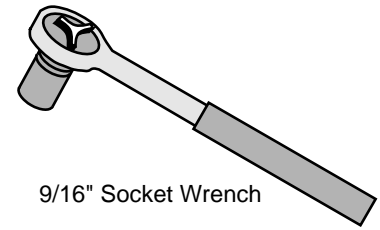
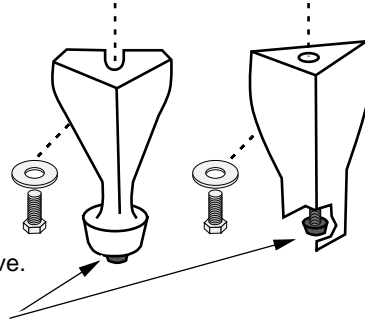

9/16" Socket Wrench

These rubber-tipped bolts are for leveling the stove. Make sure they contact the floor. Do not adjust with weight on the legs, the rubber tips may tear.

Pedestal (Part # 99200200)



If using outside air with the pedestal, follow the directions on the following page under "Outside Air Installation" prior to installing the pedestal.



Mobile Home installations require the pedestal to be attached to the floor (use the lag bolts).

- Place the pedestal into position on the floor protection. Lift the pedestal up and insert the two dowels included with this kit onto the forward and rear edge of the pedestal base.
- Lift the stove onto the pedestal base. Line up the press-nuts on the bottom of the stove with the two attachment brackets on the pedestal. Insert the two bolts, with washers, through the brackets on the pedestal and into the stove. Tighten the bolts with a 9/16" wrench.

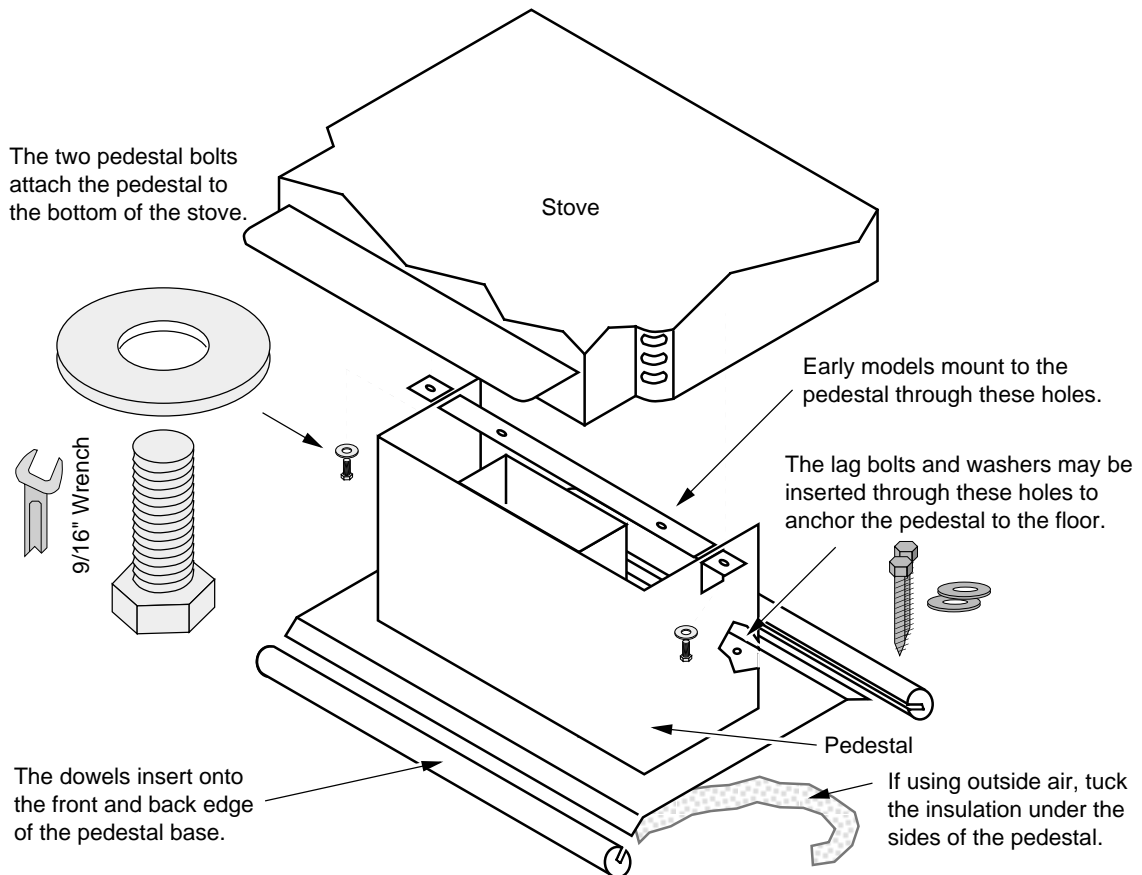

Outside Air Installation (for wood stoves only)

This pedestal has an internal air duct that may be used to direct air to the combustion chamber. Follow the directions below prior to installing the stove or attaching the pedestal.



Outside air is required for **mobile home** installations and in certain localities. Read the section "Outside Air Requirements" on page 11 prior to installing outside air.

- Before placing the stove on the pedestal, determine the location of the hole that is cut through the floor protection and floor. The illustration to the right details the location where this hole may be cut in relation to the faceplate of the stove. Cut a hole at least 16 square inches in area that does not interfere with structural members of the home.

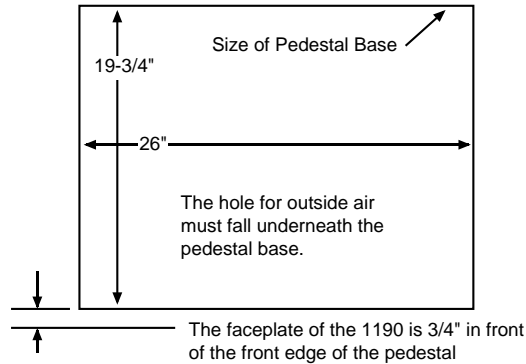

- Place the included screen (or other screen) over the hole to act as a rodent barrier. It may be attached above or below the floor. Secure the screen with the included staples.

OUTSIDE AIR EQUIPMENT

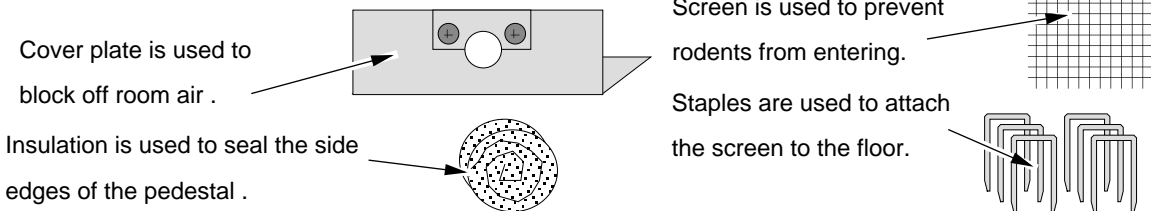

- Prop the front of the stove up 12" and pry out the outside air knockout with a large screwdriver.
- The cover plate seals the area around the air control rod. Remove the two screws and bridge from the cover plate. Slide the cover plate underneath the air control rod and re-attach the bridge.

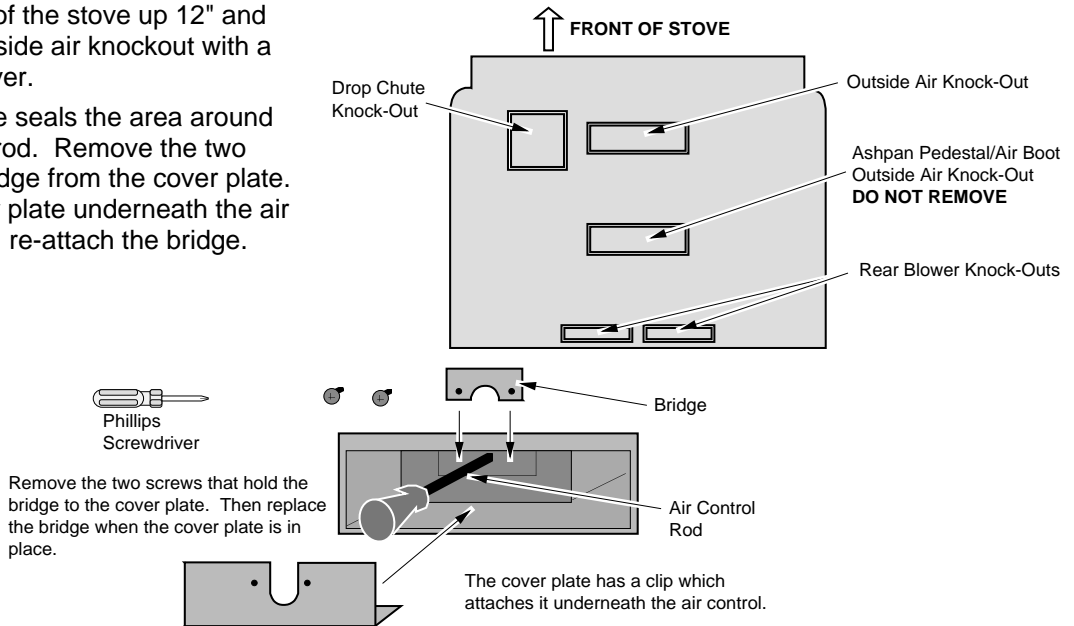

Rear Blower Installation (Part number 99000138)

The rear blower improves heat transfer by pushing heated air through the convection channel. Operating instructions are described in the section "Blower Operation" on page 30.

1. The stove should be in place with the legs installed prior to installing the rear blower.
2. Follow the directions below to install the thermodisk.

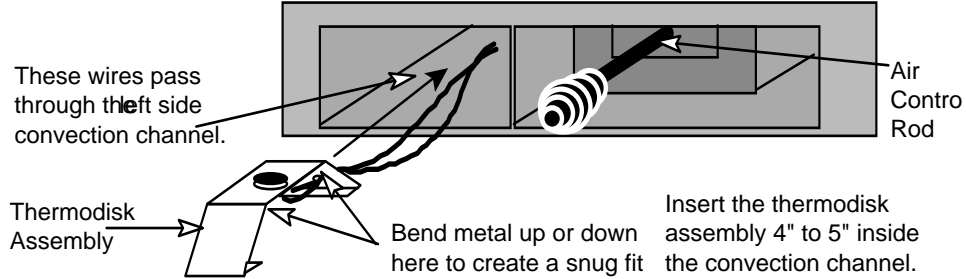

3. Install the wire clip following the directions below.

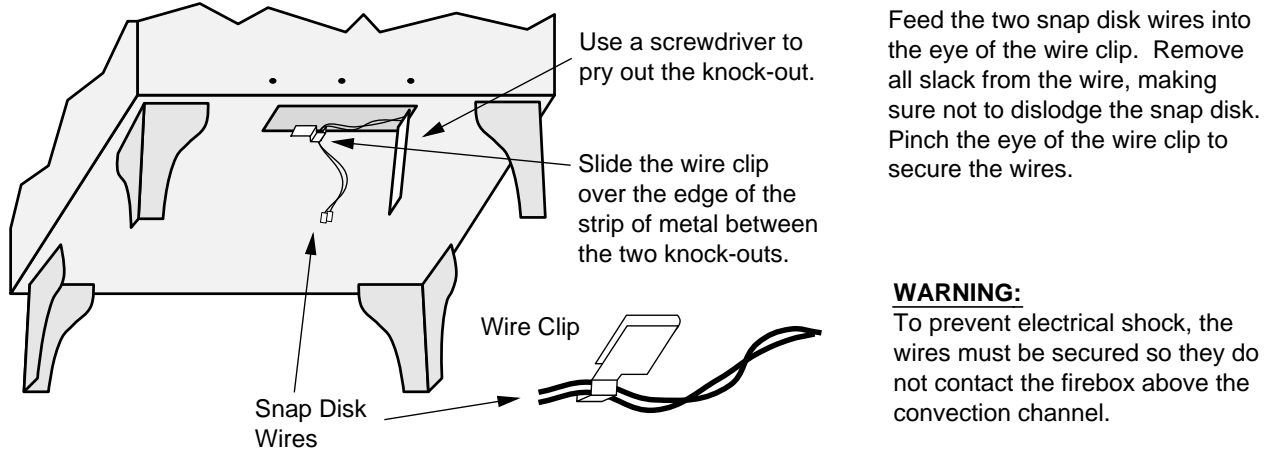

4. Attach the blower following the directions below.

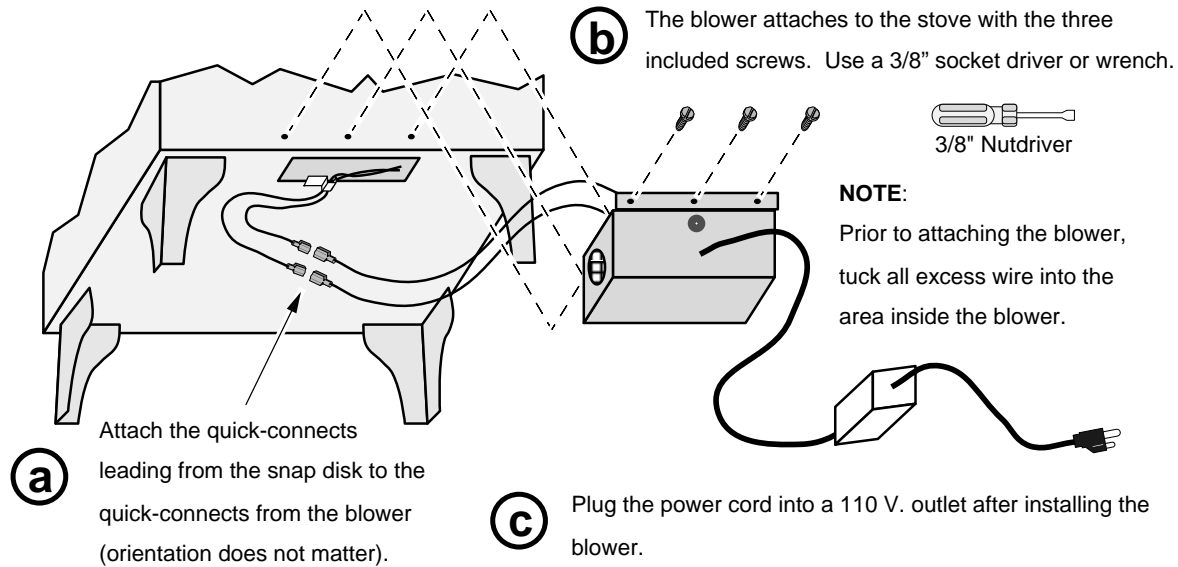

Outside Air Boot Installation (Part number 99200134)

The outside air boot routes outside air to the stove for combustion. Refer to the section "Outside Air Requirements" on page 11 for installation concerns. The directions below detail installation.

1. Install the cover plate following the directions below (use the correct cover plate).

Remove the two screws on the cover plate to remove the piece that fits over the air control rod. Then replace the piece when the cover plate is in place.

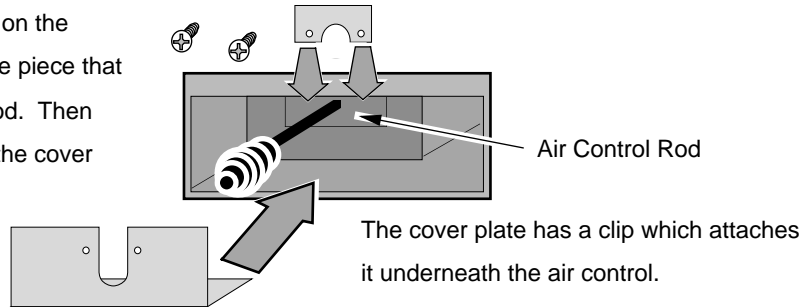

2. Refer to the illustration below to determine the location and size of the hole penetrating the floor. Cut the hole prior to locating the stove.
3. Attach gasket to the bottom edge of the lower air boot section (near the screen). Attach gasket on top of the flanges on the upper air boot section. Slide the two sections together with both seams facing the rear (do not attach the two sections at this time).
4. Follow the directions below for attaching the upper section of the air boot (with gasket) to the stove.
5. Slide the lower section down until it contacts the hearth. Attach the two sections together following the directions below

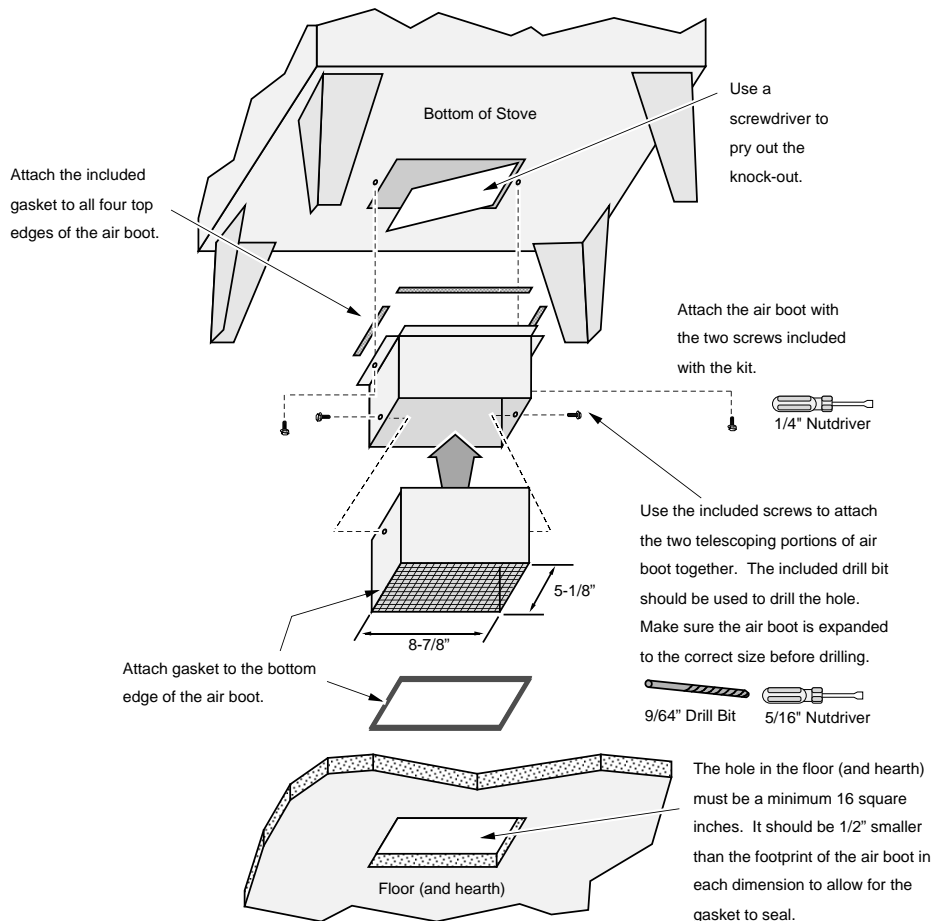

Surround Panels (see part #'s below)

Size	Size on Insert (w trim)	PART #
8"	45 1/4" wide by 28 7/8" high	99300312
10"	49 1/4" wide by 30 7/8" high	99300313
12"	53 1/4" wide by 32 7/8" high	99300314

INSTALLATION INSTRUCTIONS

1. With the insert 12" from the fireplace, install the side surround panels (see the directions to the right).
2. Adjust the position of the side panels so they are: 1) aligned with the top of the insert; 2) both the same distance back from the front of the insert; 3) perpendicular to the floor (use the top panel, if necessary, to judge alignment). Tighten the screws that hold the side panels in place.
3. Install the top panel and trim following the directions to the right.

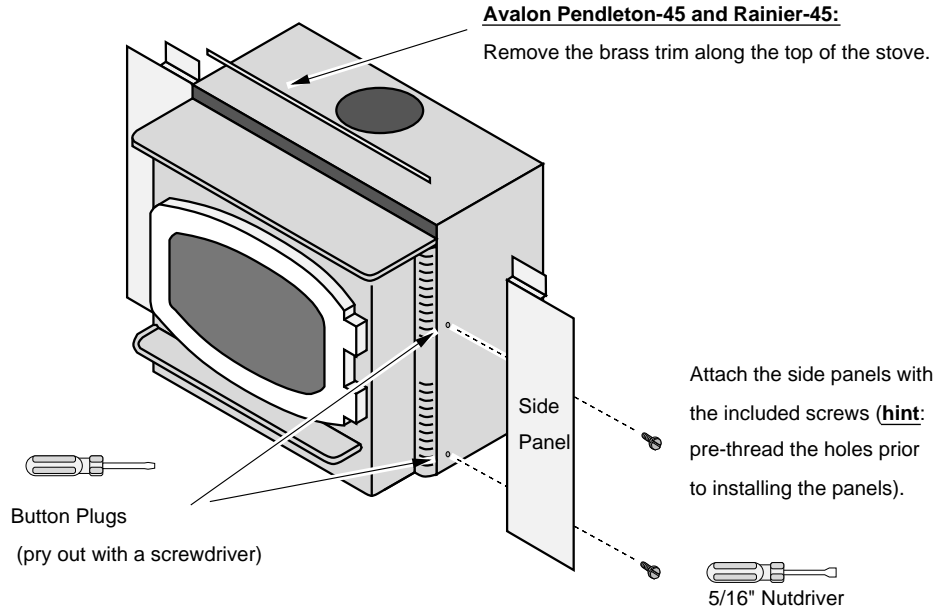

Insulation Installation (required for face seal installations only)

1. With the insert drawn 6" from the fireplace, glue the insulation strip included with the surround panel kit to the back of the panels using RTV silicon or stove gasket cement. The insulation should be installed so it overlaps the fireplace opening to form a seal between the panels and the fireplace face. Let the silicon or cement dry.
2. Push the insert into the fireplace, allowing the insulation to form a seal between the panels and the fireplace. Use a screwdriver to tuck any exposed insulation behind the panels.

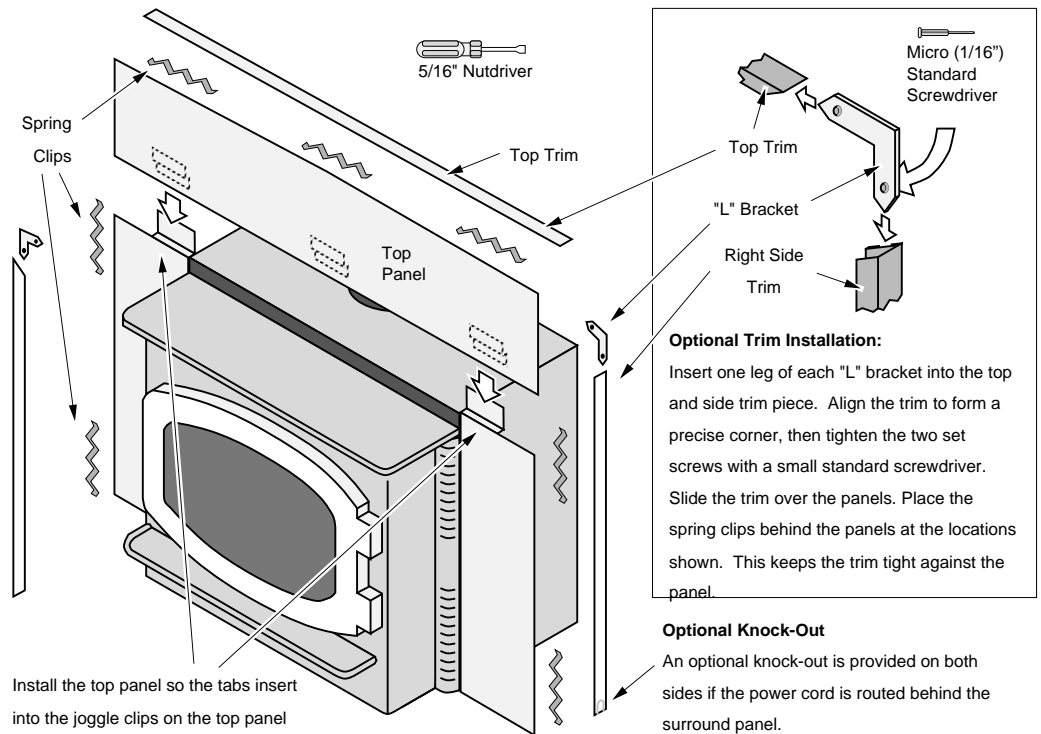

Front Blower (part # 99000190)

TO SWITCH THE POWER CORD TO THE LEFT SIDE:

Follow the directions below to switch the power cord. Make sure the power cord, wires, or molex assembly do not protrude into the opening of the blower.

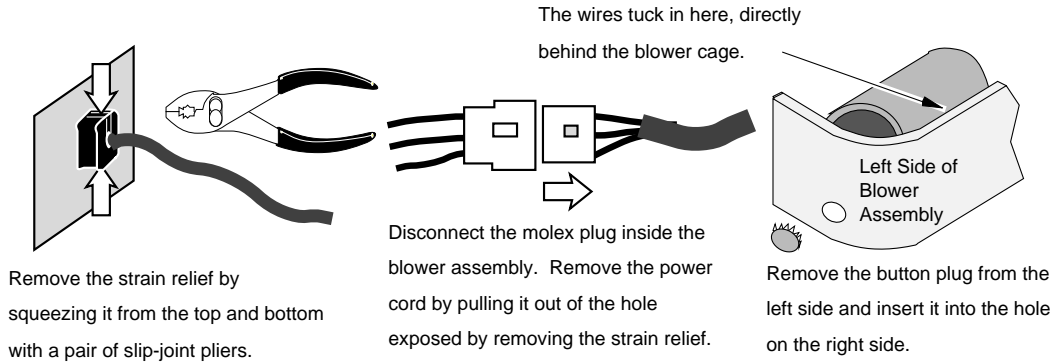

INSTALLATION INSTRUCTIONS

The Olympic (1190), requires removal of the button plug below the blower knob and installation of the air control rod extension (see illustration below).

Install the snap disk (see the illustration below. The round disc must be facing upwards and come in contact with the bottom of the firebox for the blower to operate correctly.

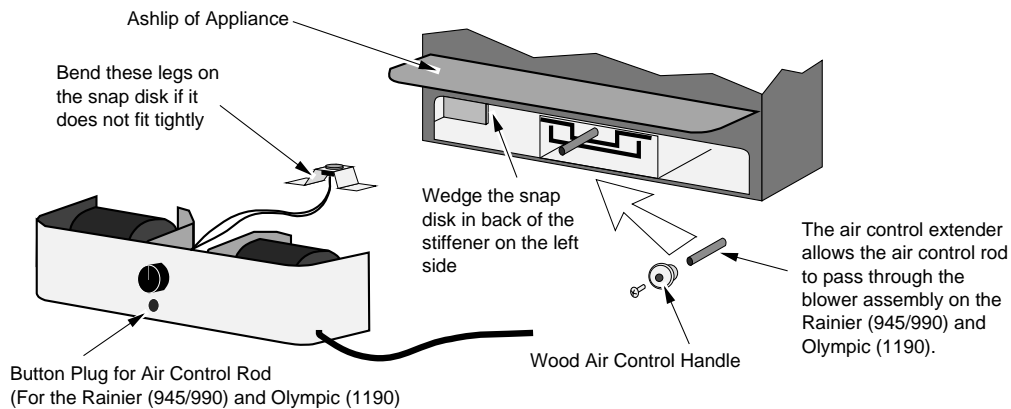

Make sure the wires leading to the snap disk are routed above the left side blower outlet (to prevent damage to the wires during installation). Install the blower following the directions below.

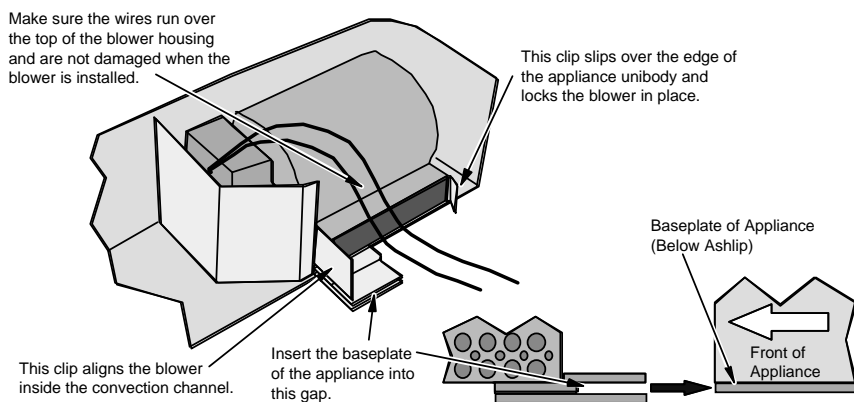

Air Control	28	Maintenance	34
Air Tube Part Number	38	Mobile Home Requirements.....	13
Air Tube Removal & Replacement	39	Monthly Maintenance	35
Alcove	12	Noise (Normal Operating Sounds)	30
Ash Disposal	34	Non-Combustible Alcove.....	12
Baffle Parts	38	Opening the Door.....	24
Baffle Removal and Replacement.....	39	Operation	17
Blower Cleaning	36	Outside Air Boot Installation.....	45
Blower Does Not Run (Troubleshooting).....	32	Outside Air	11
Blower Installation (rear)	44	Over-Firing the Stove	24
Blower Operation (optional)	30	Overnight Burn	30
Burn Rate.....	28	Paint (Touch-Up Paint).....	36
Cathedral Ceiling.....	14	Paint Curing	24
Ceiling Penetration.....	10	Rear Blower Installation	44
Chimney Cleaning.....	35	Re-Loading the Stove	30
Chimney Inspection (Creosote).....	35	Safety Label	41
Chimney Requirements.....	10	Safety Precautions	4
Chimney Termination Requirements.....	11	Smell (from paint curing)	24
Cleaning the Ash.....	34	Smoke Enters Room (Troubleshooting)	32
Cleaning the Glass.....	34	Sounds (Normal Operating Sounds)	30
Clearances (stove)	8	Starting a Fire.....	26
Close Clearance Connectors	8	Stove Does Not Burn Long Enough	32
Connector Requirements	10	Stove is Not Hot Enough (Troubleshooting).....	32
Creosote Check	35	Table of Contents.....	3
Daily Maintenance.....	34	Touch-Up Paint	36
Dimensions	6	Troubleshooting (Operation)	32
Door and Glass Inspection.....	35	Warranty Card.....	2
Door Assembly.....	37	Warranty	37
Door Gasket Replacement.....	37	Wood.....	31
Door Handle Replacement.....	37	Yearly Maintenance	36
Door Opening.....	24		
Door Parts.....	37		
Draft Performance.....	10		
Elbows (Chimney)	10		
Emissions.....	6		
EPA Approval.....	6		
Exterior Chimney.....	11		
Features.....	6		
Fire Starting	26		
Firebox Assembly.....	38		
Firebox Parts.....	38		
Firebrick and Baffle Inspection	36		
Firebrick Removal & Replacement.....	38		
Floor Protection Requirements (stove).....	8		
Glass Cleaning.....	34		
Glass Replacement.....	37		
Hearth (Floor Protection - Stove)	8		
Hearth Stove	16		
Heating Specifications.....	6		
Hints for Burns	31		
Installation Options.....	6		
Installation (stove)	7		
Leg Installation.....	42		
Listing Label.....	41		