

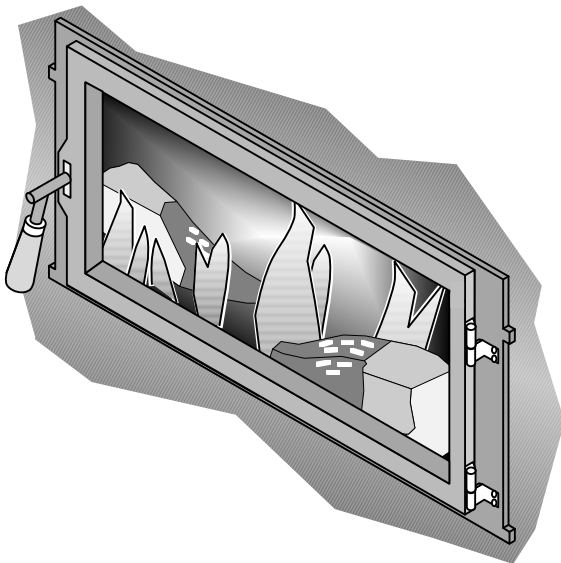

**TRAVIS INDUSTRIES  
HOUSE OF FIRE**

# Flush Wood Plus Insert (Rectangular)

## Owner's Manual



- Masonry Fireplace Insert
- Zero-Clearance (Metal) Fireplace Insert

Save these instructions for future reference

### **WARNING**



**HOT GLASS WILL  
CAUSE BURNS.  
DO NOT TOUCH GLASS  
UNTIL COOLED.  
NEVER ALLOW CHILDREN  
TO TOUCH GLASS.**

### **SAFETY NOTICE:**

If this appliance is not properly installed, a house fire may result. For your safety, follow the installation directions. Contact local building or fire officials about restrictions and installation inspection requirements in your area.

#### **Travis Industries, Inc.**

12521 Harbour Reach Drive  
Mukilteo, WA 98275  
www.travisproducts.com

© Copyright 2015, T.I.  
\$10.00 100-01259  
4150520



Tested to: U.L. 1482 & ULC S628

## Introduction

We welcome you as a new owner of a Flush Wood fireplace insert. In purchasing a Flush Wood fireplace insert you have joined the growing ranks of concerned individuals whose selection of an energy system reflects both a concern for the environment and aesthetics. This insert is one of the finest appliances the world over. This manual will explain the installation, operation, and maintenance of this appliance. Please familiarize yourself with the Owner's Manual before operating your appliance and save the manual for future reference. Included are helpful hints and suggestions which will make the installation and operation of your new appliance an easier and more enjoyable experience. We offer our continual support and guidance to help you achieve the maximum benefit and enjoyment from your appliance.

## Important Information

No other Flush Wood fireplace insert appliance has the same serial number as yours. The serial number is stamped onto the label on the back of the appliance.

This serial number will be needed in case you require service of any type.

Model: Flush Wood Plus

Serial Number: \_\_\_\_\_

Purchase Date: \_\_\_\_\_

Purchased From: \_\_\_\_\_

**Register your warranty online at:**

[traviswarranty.com](http://traviswarranty.com)

**Save Your Bill of Sale.**

To receive full warranty coverage, you will need to show evidence of the date you purchased your heater.

We suggest that you attach your Bill of Sale to this page so that you will have all the information you need in one place should the need for service or information occur.



We suggest that our woodburning hearth products be installed and serviced by professionals who are certified in the U.S. by the National Fireplace Institute® (NFI) as NFI Woodburning Specialists or who are certified in Canada by Wood Energy Technical Training (WETT).



## General Information

Introduction & Important Information .....	2
Safety Precautions .....	4
Features & Specifications .....	6

## Fireplace Insert Installation

Planning The Installation .....	7
Preparation for Installation .....	7
Additional Accessories Needed for Installation .....	7
Installation Considerations .....	7
Additional Requirements for Canada .....	7
Fireplace Requirements .....	8
Fireplace Altered Tag .....	8
Insert Placement Requirements .....	9
Hearth Requirements .....	9
Masonry Fireplace Requirements .....	9
Zero-Clearance (Metal) Fireplace Requirements .....	10
Drafting Performance .....	10
Insert Rollers .....	11
Flue Installation .....	11
Surround Panel Installation .....	12
Face Installation .....	12
Re-Routing the Electrical Cord to the Left Side .....	13
Insert with Positive Connection .....	14
Insert with Direct Connection (Masonry Fireplace) .....	14

## Operating Your Appliance

Safety Notice .....	15
Before Your First Fire .....	15
Opening the Door .....	15
Bypass Operation .....	17
Starting a Fire .....	17
Adjusting the Burn Rate .....	19
Ash Removal .....	20
Blower Operation .....	21
Re-Loading the Stove .....	21
Overnight Burn .....	21
Normal Operating Sounds .....	21
Hints for Burning .....	22
Selecting Wood .....	22
Troubleshooting .....	23

## Maintaining Your Appliance

Daily Maintenance .....	25
Remove Ash .....	25
Clean The Glass .....	25
Monthly Maintenance .....	26
Door and Glass Inspection .....	27
Check For Creosote Buildup .....	26
Yearly Maintenance .....	27
Touch Up Paint .....	27
Blower Cleaning .....	27
Firebrick and Baffle Inspection .....	27
Door Parts .....	28
Replacing the Glass .....	28
Replacing the Door Gasket .....	28
Blower and Electrical Parts .....	28
Firebox Parts .....	28
Baffle Removal and Replacement .....	29
Air Tube Removal and Replacement .....	30
Brick Removal & Replacement .....	31

## Warranty..... 32

## Listing Information..... 34

## Index..... 36

## Safety Precautions

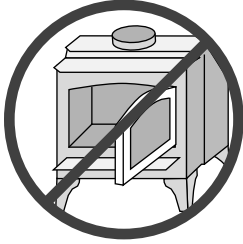

The viewing door must be closed and latched during operation.

Smoke from this appliance may activate a smoke detector when the door is open.

Never block free airflow through the air vents on this appliance.



This appliance is designed and approved for the burning of cord wood only. Do not attempt to burn any other type of fuel other than cord wood in this appliance, it will void all warranties and safety listings.



Do not touch the appliance while it is hot and educate all children of the danger of a high-temperature appliance. Young children should be supervised when they are in the same room as the appliance.



This appliance must be properly installed to prevent the possibility of a house fire. The instructions must be strictly adhered to. Do not use makeshift methods or compromise in the installation.

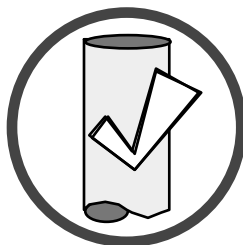

Inspect the chimney connector and chimney at least twice monthly and clean if necessary. Creosote may build up and cause a house fire.

Do not connect this appliance to any chimney serving another appliance.



Gasoline or other flammable liquids must never be used to start the fire or "Freshen Up" the fire. Do not store or use gasoline or other flammable liquids in the vicinity of this appliance.



Ashes must be disposed in a metal container with a tight lid and placed on a non-combustible surface well away from the home or structure.

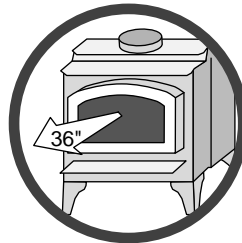

Keep furniture, drapes, curtains, wood, paper, and other combustibles a minimum of 36" away from the front of the appliance.



Contact your local building officials to obtain a permit and information on any installation restrictions or inspection requirements in your area. Notify your insurance company of this appliance as well.

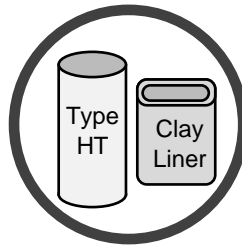

This appliance must be connected to a listed high temperature (UL 103 HT) residential type chimney or an approved masonry chimney with a standard clay tile, or stainless steel liner.



Never try to repair or replace any part of this appliance unless instructions are given in this manual. All other work must be done by a trained technician. Do not make any changes or modifications to an existing masonry fireplace or chimney to install this appliance.

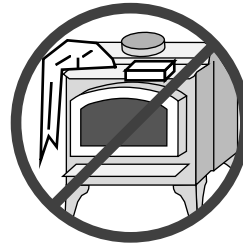

Do not place clothing or other flammable items on or near this appliance.

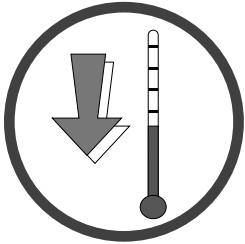

Never try to repair or replace any part of this appliance unless instructions are given in this manual. All other work must be done by a trained technician. Do not make any changes or modifications to an existing masonry fireplace or chimney to install this appliance.

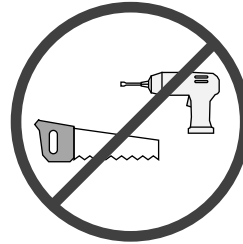

This wood heater has a manufacturer-set minimum low burn rate that must not be altered. It is against federal regulations to alter this setting or otherwise operate this wood heater in a manner inconsistent with operating instructions in this manual.



Maintain the door and glass seal and keep them in good condition.

Do not operate this heater with broken or missing glass.

Avoid placing wood against the glass when loading. Do not slam the door or strike the glass.

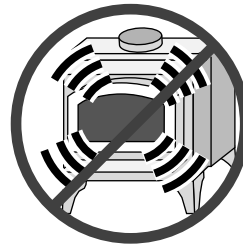

Overfiring the appliance may cause a house fire. If a unit or chimney connector glows, you are overfiring.



Do not throw this manual away. This manual has important operating and maintenance instructions that you will need at a later time. Always follow the instructions in this manual.

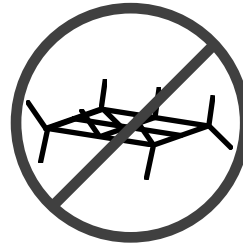

Do not use a grate or other device to elevate the fire off of the firebox floor. Burn the fire directly on the bricks.



**Travis Industries, Inc. grants no warranty, implied or stated, for the installation or maintenance of your appliance, and assumes no responsibility of any consequential damage(s).**

**Smoke and CO Detectors:** Make sure your home has a working smoke detector, especially near any bedrooms. We recommend having a smoke and/or CO detector in the same room as the wood heater for additional safety.

**Proposition 65 Warning:** Fuels used in gas, woodburning or oil fired appliances, and the products of combustion of such fuels, contain chemicals known to the State of California to cause cancer, birth defects and other reproductive harm. California Health & Safety Code Sec. 25249.6

*Travis Wood Burning Fireplaces, Stoves and Inserts are protected by one or more of the following patents; U.S. 9,170,025 4,665,889 as well as other U.S. and Foreign Patents pending.*

### Installation Options

- Masonry Fireplace Insert
- Zero-Clearance (Metal) Fireplace Insert

### Features

- 2.2 Cubic Foot Firebox Volume
- Single Operating Control
- Accepts Logs Up to 24" Long
- Steel Plate Construction (Up to 5/16")
- Heavy Duty Refractory Firebrick
- Standard High-Tech Blower

### Heating Specifications

Approximate Maximum Heating Capacity (in square feet)*	1,200 to 2,000
Maximum BTUs per Hour (Cord Wood Calculation)	73,300
Maximum Burn Time	Up to 10 Hours

\* Heating capacity will vary depending on the home's floor plan, degree of insulation, and the outside temperature. It is also affected by the quality and moisture level of the fuel.

This model was not tested for efficiency however it is assigned a default efficiency of 63% by the EPA under previous subpart AAA. Efficiency of this wood heater will be affected by the operational burn rate and the moisture content of the wood used as fuel.

### Dimensions

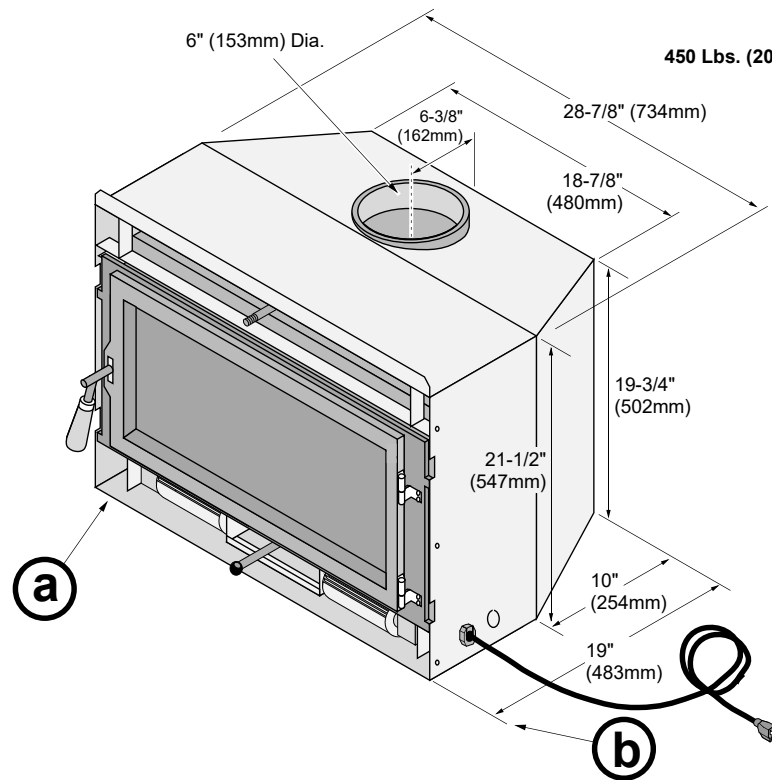

(a) Measure clearances from base of insert

(b) Fireplace Opening

Figure 1

### Emissions

This heater meets the 2015 U.S. EPA's crib wood emission limits for wood heaters sold after May 15, 2015. Tested to Method 28, 5G1 this heater has been shown to deliver heat at rates ranging from 12,100 to 29,600 BTU/hr and an emission value of 4.4g/h.

**SAFETY NOTICE:**

Please read this entire manual before you install and use your new room heater. Failure to follow instructions may result in property damage, bodily injury, or even death. Contact local building or fire officials about restrictions and installation inspection requirements in your area.

**Planning The Installation**



We suggest that you have an authorized Travis Industries dealer install your fireplace insert. If you install the fireplace insert yourself, your authorized dealer should review your installation plans.



Check with local building officials for any permits required for installation of this fireplace insert and notify your insurance company before proceeding with installation.



The location of your wood heater in your home will decide how affectively the heat produced will spread throughout your house. Attention to the home design with consideration of natural convection and air circulation should be taken into account when choosing the placement of your heater within the home.

**Preparation for Installation**

- Check for damage to the exterior of the fireplace insert (dents should be reported, scratches can be fixed by applying touch up paint).
- Check the interior of the firebox (replace cracked firebrick and make sure baffle is in place).
- The fireplace insert can be lightened by removing the firebricks and baffle (pg 31) - replace before operation.

**Additional Accessories Needed for Installation**

- Face
- Surround Panels (see page12)

**Installation Considerations**

Installation Type	Considerations
Insert with Positive Flue (Full Reline) – <u>Required in Canada</u> (Page 14)	<ul style="list-style-type: none"> <li>• Utilizes existing masonry or zero clearance fireplace</li> <li>• Provides best draft</li> <li>• Easiest to clean</li> </ul>
Insert with Direct Connect Flue (Page 14) <u>NOT APPROVED IN CANADA</u>	<ul style="list-style-type: none"> <li>• Masonry fireplace only</li> <li>• Provides good draft</li> <li>• Requires fireplace block-off plate - see page 14</li> </ul>

**Additional Requirements for Canada**

- Do not remove bricks or mortar from existing fireplace.
- This fireplace insert must be installed with a continuous chimney liner of 6” diameter extending from the fireplace insert to the top of the chimney. The chimney liner must conform to the Class 3 requirements of CAN/ULC-S635, Standard for Lining Systems for Existing Masonry or Factory-Built Chimneys and Vents, or CAN/ULC-S640, Standard for Lining Systems for New Masonry Chimneys.
- Permanently seal any opening between the masonry of the fireplace and the facing masonry.
- Fireplace insert, or surround panels, may be removed to inspect fireplace insert and fireplace.

**Ash Guard**

The included ash guard prevents ash from exiting the door opening. It is shipped detached to prevent damage during shipping.

Install the ash guard as shown below. Note how the horizontal tab fits in front of the door opening.

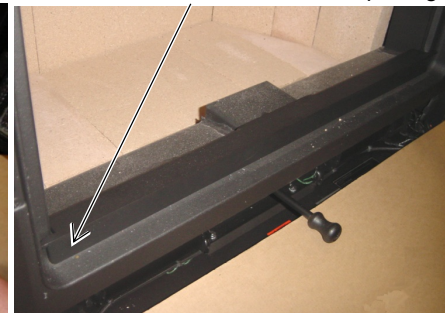

**Fireplace Requirements**

Figure 2 shows the minimum size requirements for the type of fireplace used.

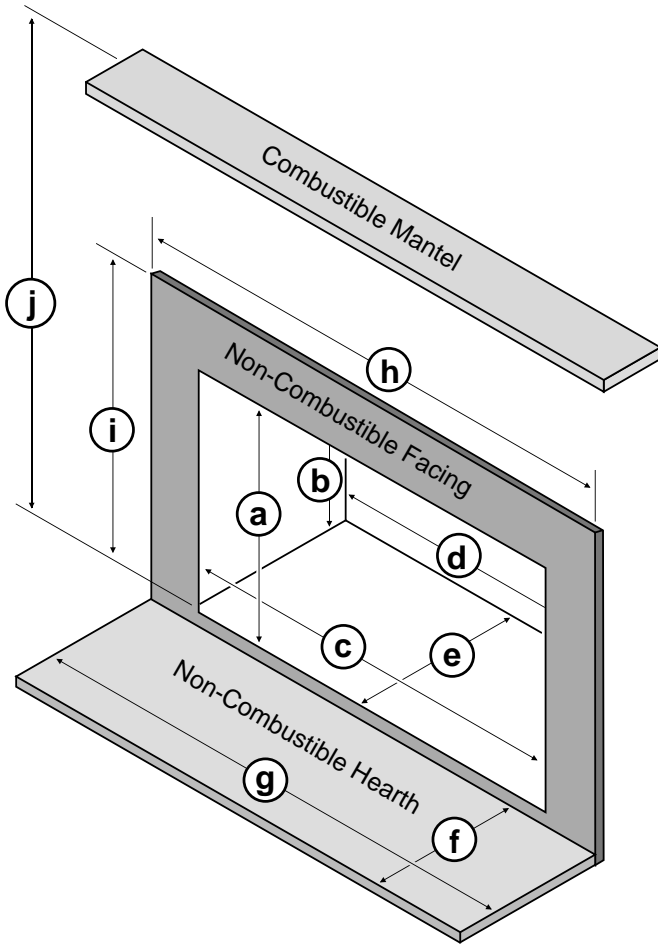

Figure 2

Minimum Fireplace Size	Masonry Fireplace	Z.C. (Metal) Fireplace
<b>a</b> Height (front)	21.5" 547mm	21.5" 547mm
<b>b</b> Height (rear)	19.75" 502mm	19.75" 502mm
<b>c</b> Width (front)	30.875" * (785mm)	30.875" ** (785mm)
<b>d</b> Width (rear)	18.875" (480mm)	20.875" ** (531mm)
<b>e</b> Depth ***	19" (483mm)	20" ** (508mm)
<b>f</b> Hearth Depth (includes insert depth on hearth plus required hearth extension)	16" 407mm (US) ----- 18" 458mm (Canada)	16" 407mm (US) ----- 18" 458mm (Canada)
<b>g</b> Hearth Width	44.875" 1140mm	44.875" 1140mm
<b>h</b> Facing Width	46.875" 1191mm	46.875" 1191mm
<b>i</b> Facing Height	39" 991mm	39" 991mm
<b>j</b> Mantel Height	41.5" 1055mm	41.5" 1055mm

\* Includes 2" (51mm) for power cord installation.

\*\* 1" (26mm) Clearance to fireplace walls is required for ZC Fireplaces.

**Fireplace Altered Tag**

Attach the "This fireplace has been altered..." plate to the fireplace (use two screws or other suitable method). You may wish to place it in a location where it will be covered by the surround panels.

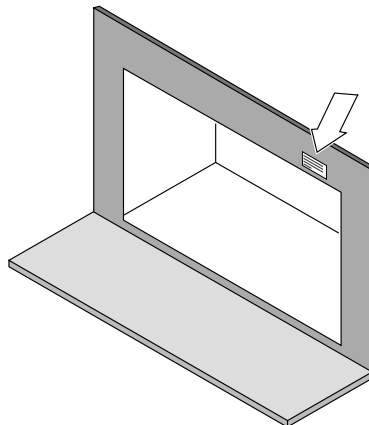

## Insert Placement Requirements

- The insert must be placed so that no combustibles are within, or can swing within (e.g. drapes, doors), 36" (915mm) of the front of the insert (Figure 3 "q").
- Insert and hearth must be installed on a level, secure floor
- The minimum clearances, facing, and hearth requirements in Figure 3 must be met. Follow the clearances for the type of fireplace being used – (masonry or zero-clearance-metal).

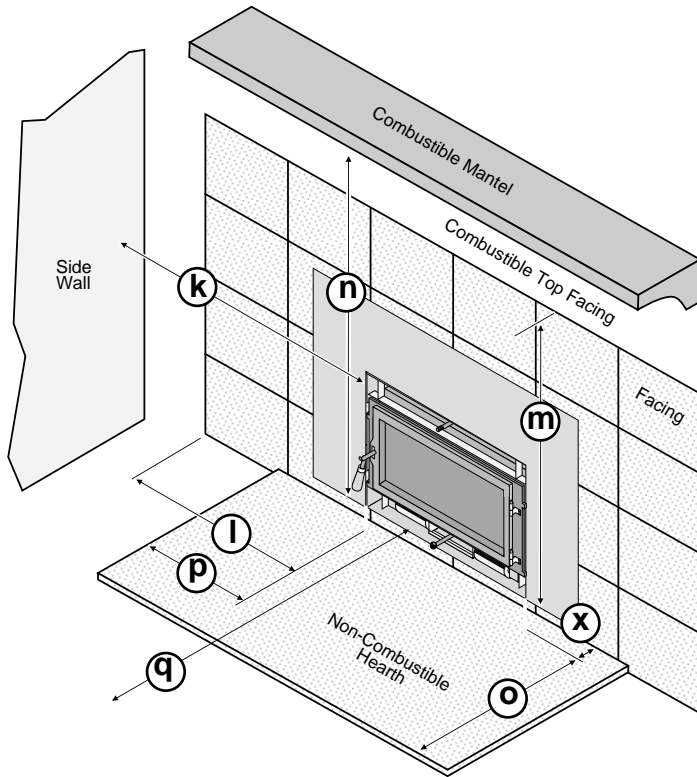

Minimum Clearances	Masonry Fireplace	Z.C. (Metal) Fireplace
<b>k Sidewall</b>	9" 229mm	9" 229mm
<b>l Side Facing (non-combustible)</b>	9" 229mm	9" 229mm
<b>m Top Facing (non-combustible)</b>	39" 991mm	39" 991mm
<b>n Mantel (combustible)</b>	41.5" 1055mm	41.5" 1055mm
<b>o Front Hearth (does not include insert extension "x")</b>	16" 407mm (US) ----- 18" 458mm (Canada)	16" 407mm (US) ----- 18" 458mm (Canada)
<b>p Side Hearth</b>	8" 204mm	8" 204mm
<b>q Front of Insert</b>	36" 915mm	36" 915mm
<b>x Extension Onto Hearth</b>	0" 0mm	0" 0mm

Figure 3

## Hearth Requirements

- Must extend 16" (USA) or 18" (Canada) in front of the insert and 8" on both sides.

## Masonry Fireplace Requirements

- Chimney must have a clay tile liner or a stainless steel liner (positive connection).
- Entire fireplace, including chimney, must be clean and undamaged. Any damage must be repaired prior to installation of the insert.
- Chimney height: 15' (4.5M) minimum; 33' (10M) maximum (measured from base of insert).
- Entire fireplace, including chimney, must meet local building requirements.
- The fireplace insert must be placed on a masonry hearth built to UBC standards.

### Zero-Clearance (Metal) Fireplace Requirements

- Must be manufactured by one of the following manufacturers:
  - Marco • Majestic • Heatilator • Preway • Tempco • Superior
  - Heat N Glo • Lennox • Martin • Monesson
- Entire fireplace, including chimney, must meet local building requirements
- Chimney height: 15' minimum; 33' maximum.
- The damper ("A") and grate ("B") must be removed (see illustration below). The smoke shelf ("C"), internal baffles ("D"), screen ("E"), and metal or glass doors ("F") may be removed (if applicable). The masonry lining ("G"), insulation ("H"), and any structured rigid frame members (metal sides, floor, door frame, face of the fireplace, etc. – "I") may not be removed or altered

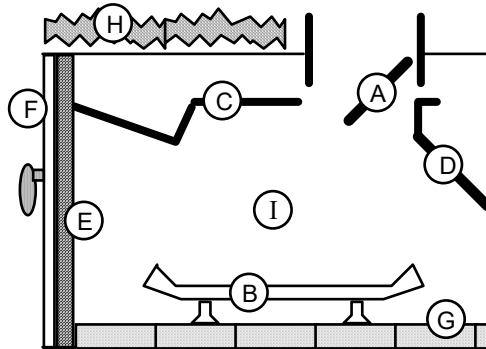

- The chimney on the ZC fireplace must be listed per UL 127 or ULC 610-M87 for all installations. Any thermal protection component of the fireplace or chimney must remain in place. The fireplace and chimney must be inspected prior to installation. A NFPA 211 Level II inspection is recommended. Repairs must be made prior to insert installation. The base of the fireplace must be structurally sound and able to support the weight of the insert.
- The stainless steel liner must be 6" diameter and extend the full height of the chimney (also called a positive connection or full re-line). This liner must meet type HT (2100°F) requirements per UL 1777 (USA) or ULC S635 with "0" clearance to masonry (Canada). The liner must be attached to the insert flue collar and to the top of the existing chimney.
- We recommend using the listed Travis ZC Liner Kit from Duravent (SKU 98900046, 47, or 48). If you do not use this kit, you must use the original ZC chimney cap.
- The liner support and cap at the top of the chimney must not reduce air flow for the existing air-cooled chimney system. The Travis ZC Liner Kit includes a cap that meets this provision.
- To prevent air from passing up the ZC fireplace chimney (the gap between the liner and chimney) we recommend sealing the area near the damper. Use non-combustible material to seal this area (non-backed fiberglass insulation or kaowool).
- The convection air channel on the fireplace must not be blocked. Do not block any louvers, grills, or air passages on the front of the fireplace.
- Entire fireplace, including chimney, must meet local building requirements. Permits may be required for installation. Final approval is contingent upon the authority having local jurisdiction. Inform you insurance agent of this fireplace insert.

### Drafting Performance

Draft is the force which moves air from the appliance up through the chimney. The amount of draft in your chimney depends on the length of the chimney, local geography, nearby obstructions and other factors. Too much draft may cause excessive temperatures in the appliance and may damage the heater. Inadequate draft may cause backpuffing into the room and 'plugging' of the chimney. Inadequate draft will cause the appliance to leak smoke into the room through appliance and chimney connector joints. An uncontrollable burn or excessive temperature indicates excessive draft.

## Insert Rollers

Two rollers are built into the back edge of the insert. This allows the insert to be rolled into position by lifting the front of the insert and pushing it into position (see Figure 4).

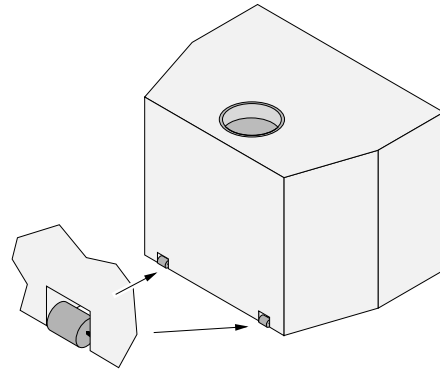

Figure 4

## Leveling Bolt Installation

**MASONRY NOTE:** Place a metal plate below the bolts on masonry fireplaces to prevent damage to the floor brick.

Two leveling bolts are pre-installed on the insert to allow for proper leveling within the fireplace. To access the bolts, remove the back corner firebricks and cover plates (see Figure 5 "a" and "b") The bolts are pre-threaded to a weld-nut on the base of the insert. Use a 3/4" socket wrench to screw the bolts down (clockwise) until the insert is level (see "c").

**SEALING THE COVER PLATE:** We recommend sealing the cover plate with furnace cement (place on underside of cover plate).

**BOLT LENGTH:** The included bolts allow approximately 1" of rise. If additional rise is required, use a longer 1/2-13 thread bolt. Make sure the additional bolt length does not interfere with the cover plate.



Figure 5

## Flue Installation

Included in the owner's pack are three "flue brackets" and six self-drilling screws. Use these components to secure the flue to the fireplace insert.

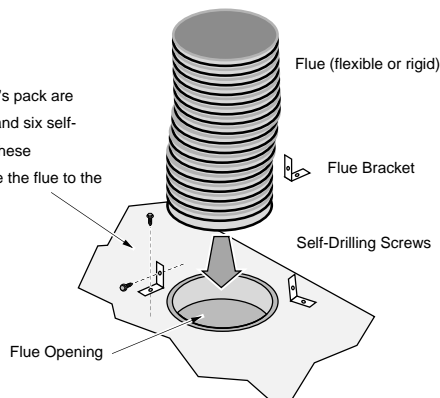

### RLH Chim-Flex Starter Sections

RLH manufactures starter sections in straight or angled configurations to suit your application. They are secured from inside the firebox, making installation much easier. Contact RLH for additional details:

[www.chim-flex.com](http://www.chim-flex.com)



## 12 Fireplace Insert Installation (for qualified installers only)

### Surround Panel Installation

	Width	Height	Part#
Standard Size	42"	30-1/2"	96100212

1. Before installing, the insert should be in place with the flue attached. Attach the brackets as shown below, using the screws included in the hardware pack with the insert. Make sure the brackets are flush with the front of the convection chamber.

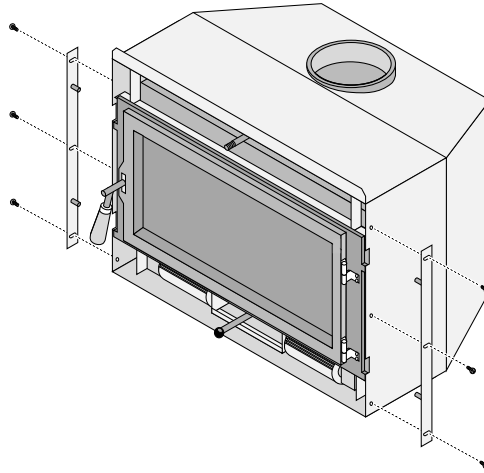

2. Attach the surround panel as shown below.

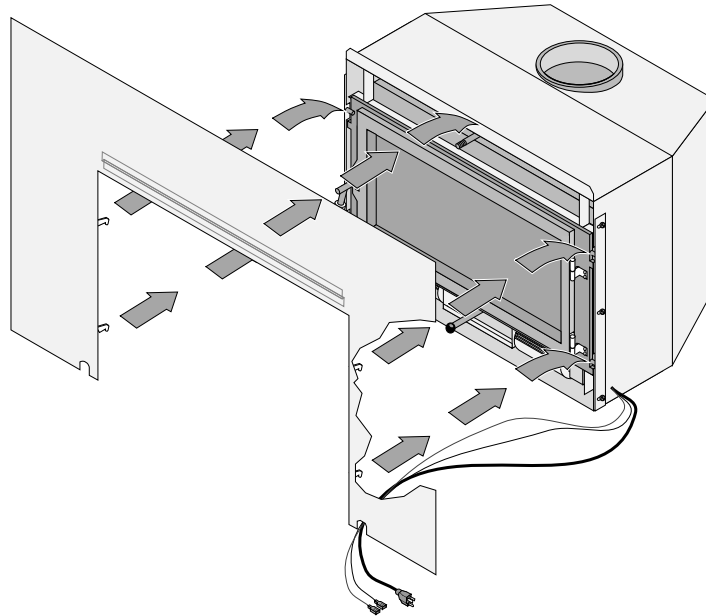

**HINT:** When installing the panel, route the wires through the notch on the bottom of the panel (either side).

### Face Installation

There are several face options available for this fireplace insert. Refer to the instructions included with your face.

## Re-Routing the Electrical Cord to the Left Side

The power cord is connected to the right side of the insert when it leaves the factory. It may be re-routed to the left side following the directions below. Do this procedure before installing the surround panels.

- Disconnect the moxex connector and remove the power cord following the directions below.

**NOTE:** An additional knockout is provided if using the insert wiring kit. Route the power through one hole, the rheostat through the other.

Disconnect the moxex connector leading from the power cord.

Use pliers to compress the strain relief from the top and bottom while pulling it out of the hole in the side of the insert.

Leave the rheostat wires in place.

**Make sure the power cord is disconnected prior to conducting these steps.**

Remove the power cord.

- Connect the power cord to the left side following the directions below.

Attach the moxex connector on the power cord to the moxex connector on the left side of the insert.

Re-attach the strain relief to the left side (use pliers to compress the strain relief from the top and bottom while pushing it into the hole).

Remove the button plug from the left side.

**Insert with Positive Connection**

**REQUIRED IN CANADA.**

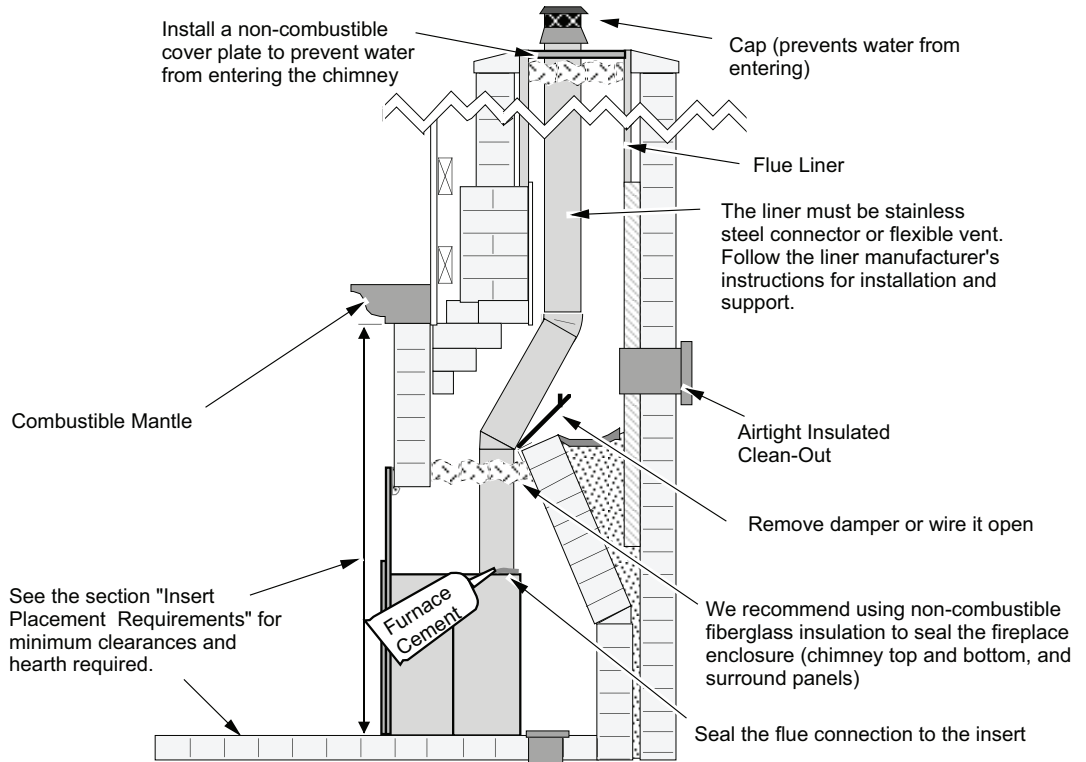

Figure 6

**Insert with Direct Connection (Masonry Fireplace)**

**NOT ALLOWED IN CANADA.**

A block-off plate or other non-combustible sealing device (e.g. damper adapter) is required. It must seal the chimney to insure smoke does not enter the home while providing the chimney system with sufficient draft.

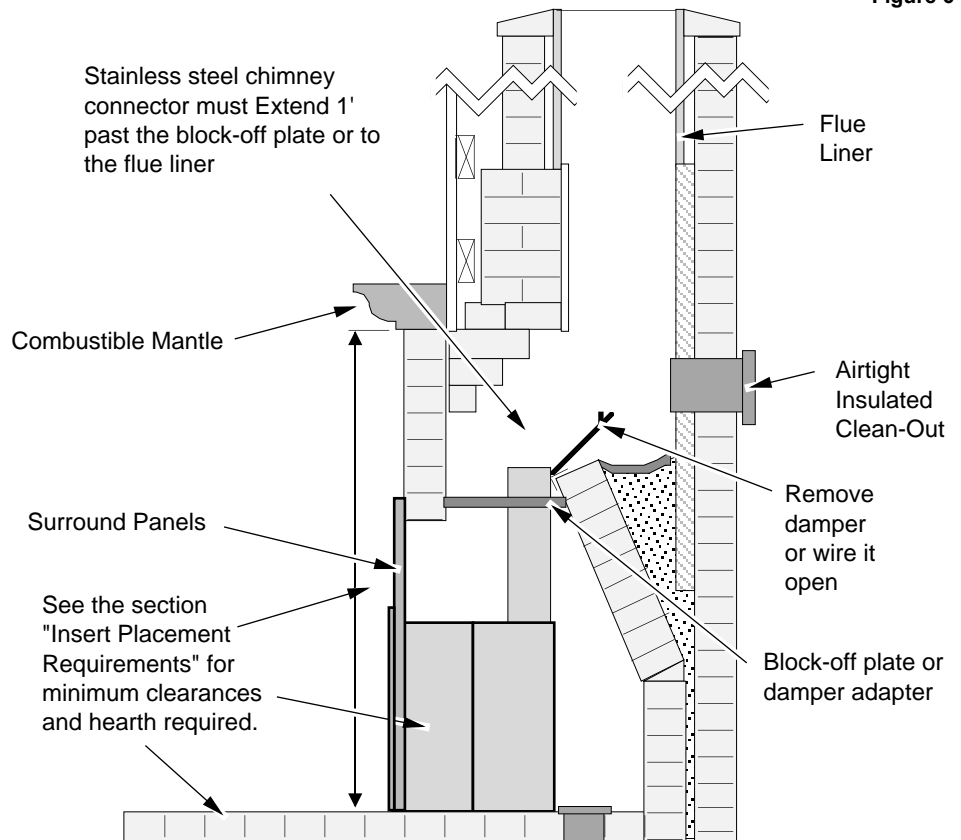

Figure 7

## Safety Notice



If this appliance is not properly installed, a house fire may result. For your safety, follow the installation directions. Contact local building or fire officials about restrictions and installation inspection requirements in your area.



Read and follow all of the warnings on pages 4 and 5 of this manual.

## Before Your First Fire

### Verify the Installation

Before starting the stove, verify that the stove is properly installed and all of the requirements in this manual have been followed.



Keep all flammable materials 36" away from the front of the stove (drapes, furniture, clothing, etc.).

## Curing the Paint

Follow the steps below to cure the paint (first fire):

- Open doors and windows in the room to ventilate the heater during the curing process.
- Vacate the room. The fumes from the initial heating process are non-toxic but may be unpleasant.
- Slowly bring the heater to a medium burn (400°F/204°C) for 45 minutes. Then increase the burn temperature to a hot burn (600°F/315°C) for an additional 45 minutes. This will cure the paint.

2 to 4 hours

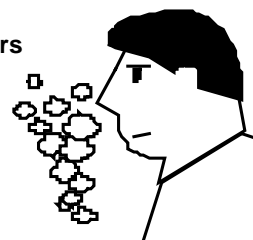

**Door Gasket** - The door gasket might adhere to the paint on the front of the heater. Leave the door slightly ajar for the first fire and be careful when opening the door after the first fire.

## Carbon Monoxide (CO) Emissions

Smoke from wood heaters contain CO. This gas is an indication of incomplete combustion and is detrimental to the environment and to your health. The more visible the smoke, the higher the CO levels. Burning dry wood is the most significant step you can take to reduce CO emissions. It is also important to understand the combustion process so you can burn your heater efficiently. Read the manual thoroughly so that you can operate your heater in the most efficient and clean manner possible.

## Over-Firing the Stove

**DO NOT OVERFIRE THIS HEATER:** Attempts to achieve heat output rates that exceed heater design specifications can result in permanent damage to the heater.

This stove was designed to operate at a high temperature. But due to differences in vent configuration, fuel, and draft, this appliance can be operated at an excessive temperature. If the stove top or other area starts to glow red, you are over-firing the stove. Shut the air control down to low and allow the stove to cool before proceeding.



Over-firing may lead to damage of plated surfaces. If any portion of the heater glows red, it is considered over-firing and will void the warranty.

### Opening the Door



The door becomes hot during use. Use a glove to open the door if the handle is hot.



To prevent smoke from entering the room, open the bypass before opening the door (see following page for directions). You can also open the door a small amount and let air enter the firebox.

### Opening the Doors

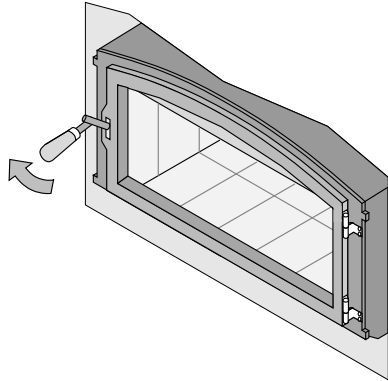

Rotate the handle up.

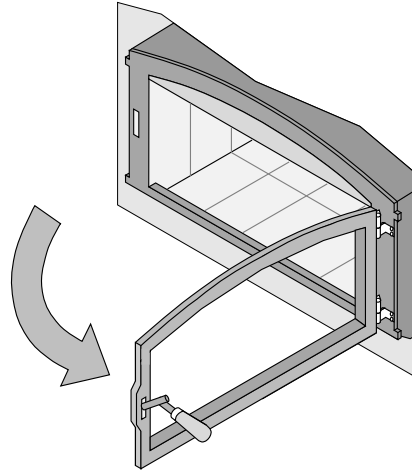

Swing the door open.

### Closing the Doors

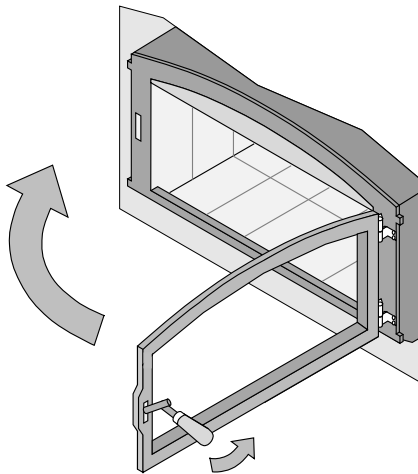

Lift the handle and close the door.

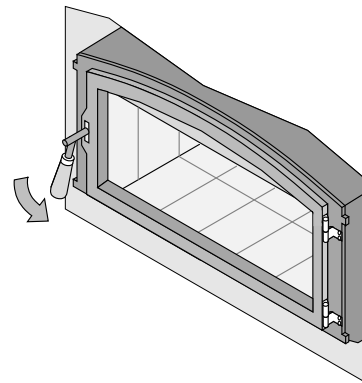

Rotate the handle down to secure the door.

## ***Bypass Operation***

The bypass controls the flow of smoke inside the heater. When pulled out, smoke goes directly up the flue, creating more draft. When pushed in, the smoke goes around the baffle, utilizing the secondary combustion and making the heater more efficient.

- When starting or re-loading, pull the bypass out.
- During normal operation, push the bypass in.

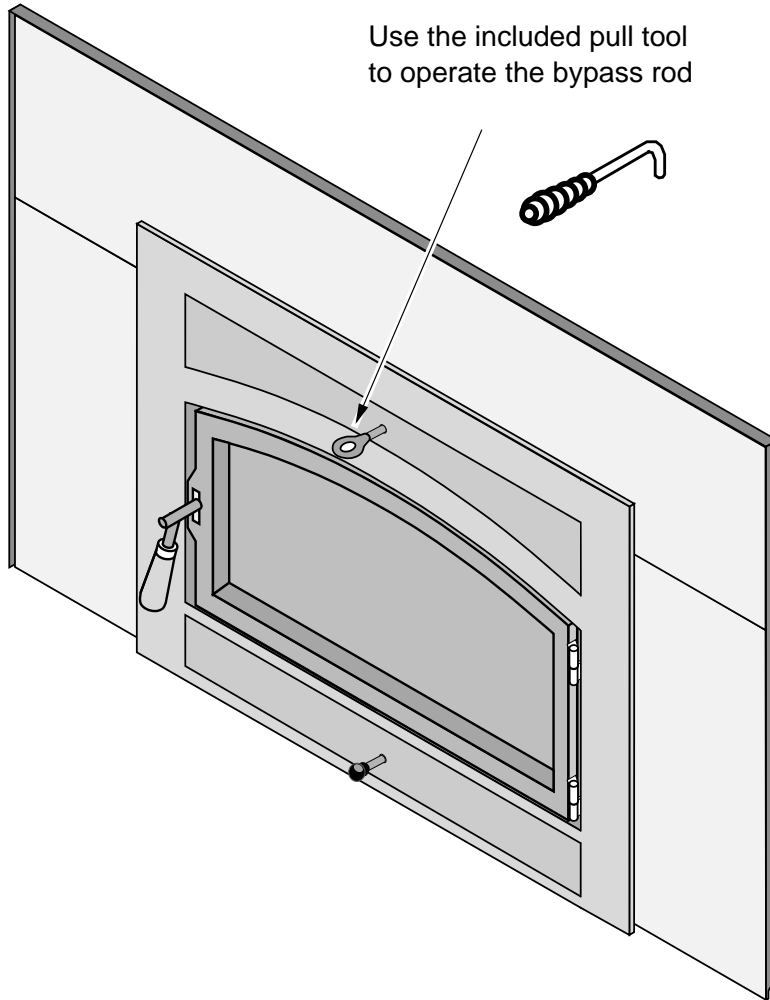

### **Bypass Pulled Out**

Used for starting and re-loading

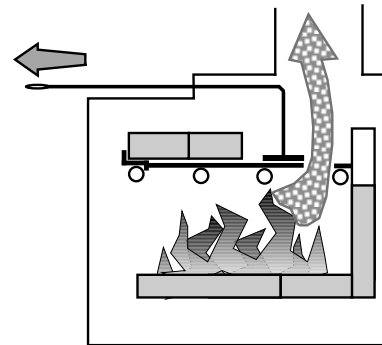

### **Bypass Pushed In**

Used for normal operation

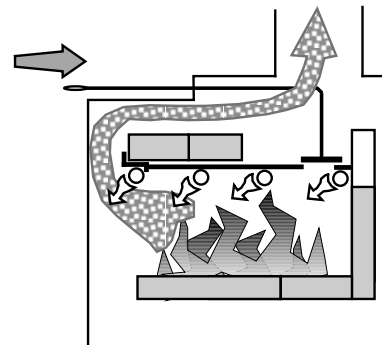

## Starting a Fire

Since the dawn of time man has debated the best way to start a fire. Some use the boy-scout "tee-pee", some prefer the "tic-tac-toe" stack. Either way, review the hints and warnings below to ensure proper fire starting.

- Make sure the air control is pushed in and the by-pass pulled out. If additional air is needed, open the doors 1/4" during the first five minutes of start-up.

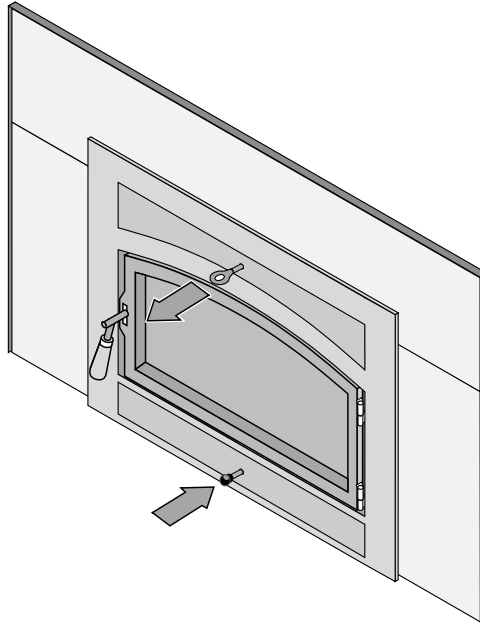

**Never** use gasoline, gasoline-type lantern fuel, kerosene, charcoal lighter fluid, or similar liquids to start or "freshen up" a fire in this stove. Keep all such liquids well away from the stove while it is in use.



**DO NOT USE CHEMICALS OR FLUIDS TO START THE FIRE. DO NOT BURN GARBAGE OR FLAMMABLE FLUIDS SUCH AS GASOLINE, NAPHTHA OR ENGINE OIL.** Do not place such fuel within space heater installation clearances or within the space required for charging and ash removal.



If using a firestarter, use only products specifically designed for stoves - follow the manufacturer's instructions carefully.



**HOT WHILE IN OPERATION. KEEP CHILDREN, CLOTHING AND FURNITURE AWAY. CONTACT MAY CAUSE SKIN BURNS.**



If the smoke does not pass up the chimney, ball up one sheet of newspaper, place it in the center of the firebox and light it. This should start the chimney drafting (this eliminates "cold air blockage").



Use plenty of kindling to ensure the stove reaches a proper temperature. Once the kindling is burning rapidly, place a few larger pieces of wood onto the fire.

### Starting a "Top-Down Fire"

One particularly successful method for starting a fire is to stack several large pieces of wood in the center of the stove (see the illustration to the right). Then place a several wads of newspaper in the center with kindling on top. When you light the newspaper this "top-down" fire will burn its way to the center, igniting the larger pieces. With some practice, this method should work for you.

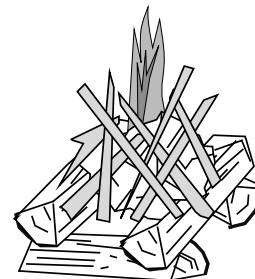

## Adjusting the Burn Rate

Use the air control slider to control the burn rate of the stove. See the illustration below for details.

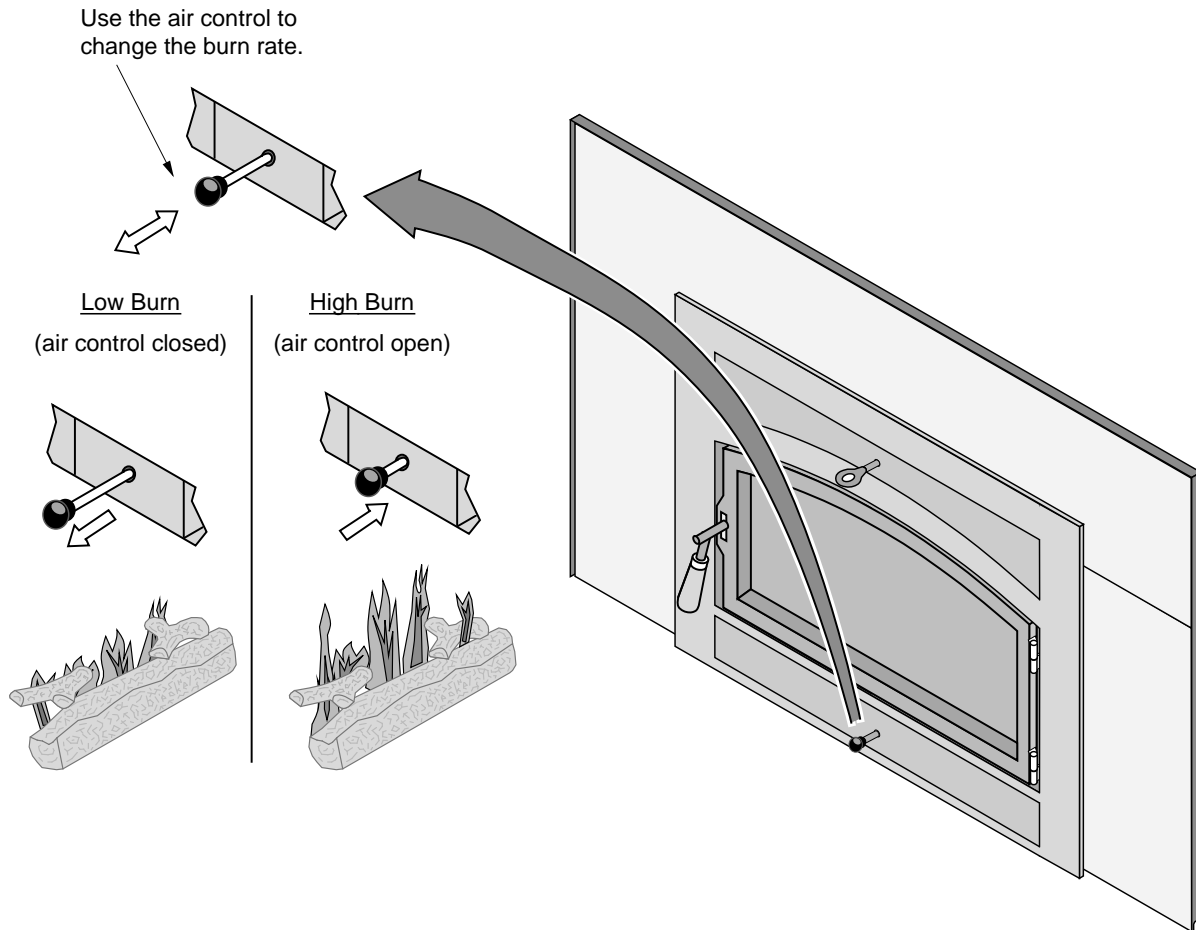

### Approximate Air Control Settings:

Overnight Burn	Pulled Fully Out to 1/32" In
Medium Burn	1/32" to 1/16" In
Medium High Burn	1/16" to 3/16" In
High Burn	3/16" to Pushed All the Way In



The air control becomes hot during operation - use gloves or a tool to prevent burns.



The air control may take several minutes to influence the burn rate. When making adjustments, you may wish to let the stove burn for 10 minutes to gauge performance.

## ***Understanding Your Heater's Combustion System***

---

This heater uses a dual combustion system detailed below:

**Primary Combustion:** This is the combustion (fire) that takes place directly on the wood. Primary combustion determines how fast the fire burns. Air for primary combustion is supplied through the air control. When you adjust the air control you control the amount of air that reaches the fire and creates primary combustion. The air control supplies air to the air wash (the air holes above the door opening – used to help clean the glass) and through the pilot orifice (center bottom of the door opening). By using the air control, and supplying air through these two openings, you control primary combustion.

**Secondary Combustion:** This is the combustion (fire) that does not contact the wood. Secondary combustion burns the visible emissions or smoke that is not consumed during primary combustion. During some phases of combustion you will see secondary combustion. It appears as a glowing flame at the top of the firebox. Air for secondary combustion is supplied by the air tubes at the top of the firebox.

### **Items to Consider:**

- During medium and high burn rates the stove will manage secondary and primary combustion on its own. When the heater is set to a low burn rate more care is needed to ensure the secondary combustion system works properly. Make sure the stove is hot and a good coal bed is established before adjusting your heater to low burn.
- Understanding the combustion system in this heater will help minimize the visible emissions this heater releases into the environment. The primary pilot orifice at the center bottom of the door opening is designed to help the secondary combustion at low burn settings. The pilot provides a small amount of air that burns up through the fuel load providing the heat and flame needed for the secondary system to ignite. The air tubes under the baffle need to remain ignited for low burns to be effective.
- As you load your heater for a low burn, take care in placing the wood. This will affect how well your secondary system works as the wood is consumed. Do not block the pilot orifice. Stack wood so the pilot air can burn its way up between the pieces, helping your heater burn effectively throughout the low fire. This will reduce the visible emissions your heater produces and increase the amount of heat you get from the wood. If you are unsure how well your heater is burning look at the chimney cap to monitor visible emissions.

## ***Burning Your Heater***

---

**Starting a Fire:** When starting a fire it is imperative to get the heater hot and drafting as quickly as possible. This promotes combustion and reduces emissions. There are many ways to start a fire and you will become adept as you become familiar with the way your heater burns. Before you start, make sure your burn rate setting (air control) is all the way open and the by-pass (if equipped) is open. We suggest that you use a layer of crumpled newspaper covered with a three layers of small kindling, stacked tic tac toe style with approximately ½"-1" gaps between them. Continue to layer wood on top of the kindling with the same air gaps using slightly bigger pieces increasing in size as you stack upward with the final layer being 3-5" diameter pieces loaded on the top. This should fill the firebox. Light the newspaper in several places near the door opening. Shut the door but do not latch it, creating a small opening to allow air to feed the kindling fire. Never leave your heater unattended if your door is not latched shut. While the kindling burns the fire will heat and ignite the larger pieces above. Once the whole load is burning shut and latch the door leaving the burn rate on high. Depending on your heater, the chimney, and the outside environment, you may need to leave your bypass open for up to 20 minutes after lighting the fire. If the fire dies when you shut the bypass you will need to leave it open longer. The presence of a hot coalbed is critical to good combustion. We cannot overstate the importance of a hot coal bed before slowing your burn rate or re-loading your heater. We recommend that you allow the first ignition load of wood to burn through at the high burn rate. This will get your heater up to temperature and establish a coal bed.

**Reloading:** When reloading a hot heater set the burn rate on high for at least 15 min before slowing it down.

**Low Burn:** If preparing for an overnight or low burn a longer heat up period may be necessary. Reload the heater full of wood making sure there are air gaps between the wood pieces so the pilot air can burn up through the middle load keeping the secondary combustion system hot and active throughout the burn. After loading, burn the heater on high for at least 15 minutes before setting the air control to low. Excessive creosote buildup (or sooting) in the heater at the end of a low burn signifies that the heater was not hot enough and the wood load was not burned long enough on high after loading before shutting down the air control.

## Blower Operation

The blower will turn on once the stove is up to temperature. This is typically 15 to 30 minutes after starting the fire. Follow the directions below to alter the blower speed.



The blower rheostat dial may look different. It does operate in the same fashion.

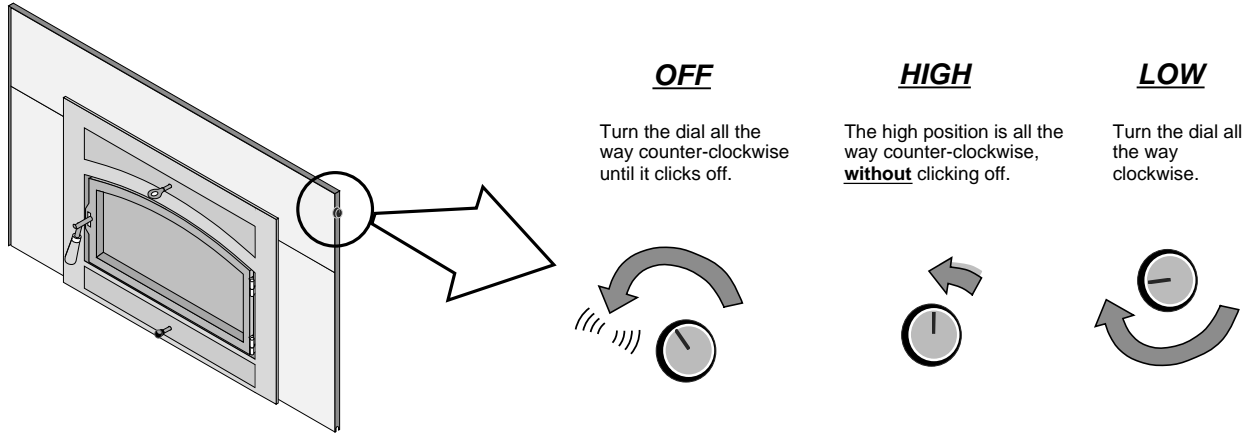

The blower may be used to affect heat output (i.e.: to reduce heat output, turn the blower down).



Route the power cord in a location where it will not come in contact with the appliance or become hot.

## Re-Loading the Stove

Follow the directions below to minimize smoke spillage while re-loading the stove.

- 1 Open the air control all the way (push it in). Open the bypass (pull it out).
- 2 Open the door slightly. Let airflow inside the firebox stabilize before opening the doors fully.
- 3 Load wood onto the fire.

## Overnight Burn

Follow the steps below to achieve an overnight burn.

- 1 Move the air control to high burn and let the stove become hot (burn for approximately 15 minutes).
- 2 Load as much wood as possible. Use large pieces if possible.
- 3 Let the stove burn on high for 15 minutes to keep the stove hot, then turn the air control to low.
- 4 In the morning the stove should still be hot, with embers in the coal bed. Stir the coals and load small pieces of wood to re-ignite the fire, if desired.



Differences in chimney height and draft may lower overall burn times.

## Normal Operating Sounds

### Creaks and Clicks:

The steel may creak or click when the stove heats up and cools down - this is normal.

### Blower Sounds:

The blower will make a slight "hum" as it pushes air through the stove.

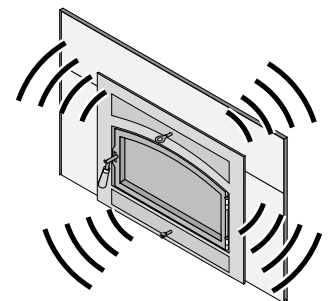

## Hints for Burning

- Get the appliance hot before adjusting to low burn
- Use smaller pieces of wood during start-up and high burns to increase temperature
- Use larger pieces of wood for overnight or sustained burns
- Stack the wood tightly together to establish a longer burn
- Be considerate of neighbors & the environment: burn dry wood only
- Burn small, intense fires instead of large, slow burning fires when possible
- Learn your appliance's operating characteristics to obtain optimum performance

## Selecting Wood

- Dry Wood is Key
- Dry wood burns hot, emits less smoke and creates less creosote.
- Testing Wood Moisture
- Split wood stored in a dry area will be fully dry within a year. This insures dry wood. If purchasing wood for immediate use, test the wood with a moisture meter. Some experienced wood burners can measure wood moisture by knocking pieces together and listening for a clear "knock" and not a "thud".

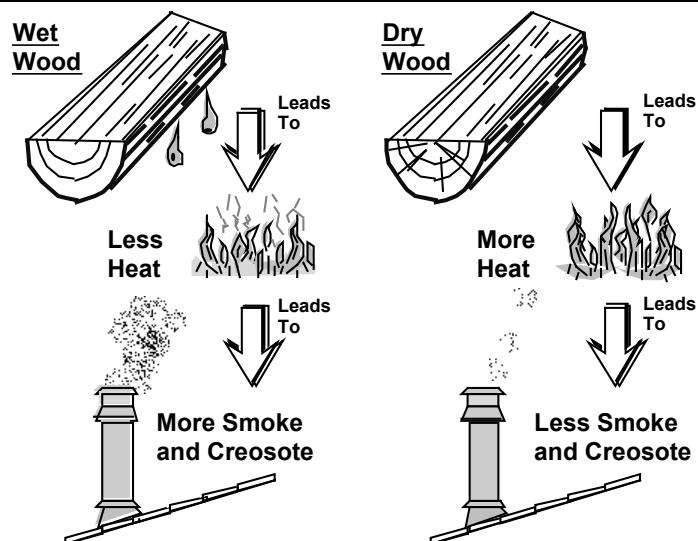

## Why Dry Wood is Key

Wet wood, when burned, must release water stored within the wood. This cools the fire, creates creosote, and hampers a complete burn. Ask any experienced wood burner and he or she will agree: dry wood is crucial to good performance.

## Wood Cutting and Storage

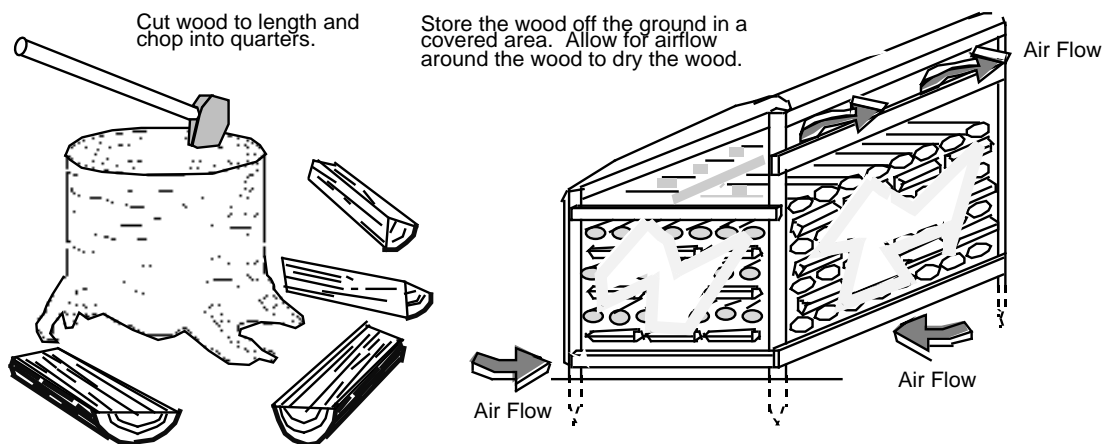

**Do Not Burn List**

This heater is designed to burn natural wood only. Higher efficiencies and lower emissions generally result when burning air dried seasoned hardwoods, as compared to softwoods or to green or freshly cut hardwoods. **DO NOT BURN:**

- (1) Garbage;
- (2) Lawn clippings or yard waste;
- (3) Materials containing rubber, including tires;
- (4) Materials containing plastic;
- (5) Waste petroleum products, paints or paint thinners, or asphalt products;
- (6) Materials containing asbestos;
- (7) Construction or demolition debris;
- (8) Railroad ties or pressure-treated wood;
- (9) Manure or animal remains;
- (10) Salt water driftwood or other previously salt water saturated materials;
- (11) Unseasoned wood; or
- (12) Paper products, cardboard, plywood, or particleboard. The prohibition against burning these materials does not prohibit the use of fire starters made from paper, cardboard, saw dust, wax and similar substances for the purpose of starting a fire in an affected wood heater.

**Burning these materials may result in release of toxic fumes or render the heater ineffective and cause smoke.**

**Troubleshooting**

<b>Problem</b>	<b>Possible Cause</b>
<b>Smoke Enters Room During Start-Up</b>	<ul style="list-style-type: none"> <li>• Open the bypass (pg. 17).</li> <li>• Open the air control (pg. 19).</li> <li>• Cold Air Blockage - burn a piece of newspaper to establish a draft.</li> <li>• If the flame is not getting enough air, a small crack in the door is all that is needed.</li> </ul>
<b>Kindling Does Not Start - Fire Smolders</b>	<ul style="list-style-type: none"> <li>• Open the bypass (pg. 17).</li> <li>• Open the air control (pg. 19).</li> <li>• Not enough starter paper - use additional newspaper if necessary.</li> <li>• If the flame is not getting enough air, a small crack in the door is all that is needed.</li> </ul>
<b>Smoke Enters Room While Re-Loading</b>	<ul style="list-style-type: none"> <li>• Open the bypass before opening the door (pg. 17).</li> <li>• Open the air control before opening the door (pg. 19).</li> <li>• Let the air stabilize before fully opening the door. Then open the door approximately 1 inch. Let air go into the firebox for a few seconds. Once the smoke appears to be flowing up the chimney consistently, open the door.</li> <li>• Insufficient Draft - Chimney height and outside conditions can negatively affect draft. In these cases a small amount of smoke may enter the home. Adding more pipe or a draft-inducing cap may help.</li> </ul>
<b>Stove Does Not Burn Hot Enough</b>	<ul style="list-style-type: none"> <li>• Wood is Wet - see the section "Selecting Wood" on page 22 for details on wood.</li> <li>• Make sure the air control is all the way open. Slide the control back and forth to insure the control is not stuck.</li> <li>• Insufficient Draft - Chimney height and outside conditions can negatively affect draft. In these cases the fire may burn slowly. Adding more pipe or a draft-inducing cap may help.</li> </ul>
<b>Blower Does Not Run</b>	<ul style="list-style-type: none"> <li>• Stove is Not Up to Temperature - This is normal. The blower will come on when the stove is hot - usually 15 to 30 minutes.</li> <li>• Electricity is Cut to the Blower - Check the household breaker or fuse to make sure it is operable.</li> </ul>
<b>Stove Does Not Burn Long Enough</b>	<ul style="list-style-type: none"> <li>• Depending upon wood, draft, and other factors, the burn time may be shorter than stated. Make sure the doors are sealing and not allowing air into the firebox - See the section "Door and Glass Inspection" on page 26 for details.</li> <li>• Check the ash bed for coals. Often, coals are still glowing under a slight bed of flyash. By raking these into a pile you can re-start your stove quickly.</li> </ul>



Failure to properly maintain and inspect your appliance may reduce the performance and life of the appliance, void your warranty, and create a fire hazard.



Establish a routine for the fuel, wood burner and firing technique. Check daily for creosote build-up until experience shows how often you need to clean to be safe. Be aware that the hotter the fire the less creosote is deposited, and weekly cleaning may be necessary in mild weather even though monthly cleaning may be enough in the coldest months. Contact your local municipal or provincial fire authority for information on how to handle a chimney fire. Have a clearly understood plan to handle a chimney fire.

## Daily Maintenance (while stove is in use)

### Remove Ash (if necessary)

Whenever ashes get 3 to 4 inches deep in your firebox or ash pan, and when the fire has burned down and cooled, remove excess ashes. Leave an ash bed approximately 1 inch deep on the firebox bottom to help maintain a hot charcoal bed. Let the stove cool completely before removing ashes (wait at least two hours after the last coal has extinguished). Ashes should be placed in a metal container with a tight-fitting lid. The closed container of ashes should be placed on a noncombustible floor or on the ground, away from all combustible materials, pending final disposal. The ashes should be retained in the closed container until all cinders have thoroughly cooled.

- Follow the directions below to remove ash.
  - 1 Let the stove cool completely (at least two hours after the last coal has extinguished).
  - 2 Place a cloth or cardboard protector over the hearth to catch ash and protect against scratching.
  - 3 Open the doors and scoop the ash into a metal container with a tight fitting lid. The closed container of ashes should be placed on a noncombustible floor or on the ground, away from all combustible materials, pending final disposal.



Improperly disposed ashes lead to fires. Hot ashes placed in cardboard boxes, dumped in back yards, or stored in garages, are recipes for disaster.



Wood-burning stoves are inherently dirty. During cleaning have a vacuum ready to catch spilled ash (make sure ash is entirely extinguished).



There are vacuum cleaners specifically made to remove ash (even if the ash is warm). Contact your dealer for details.

### Clean the Glass (if necessary)

This appliance has an airwash to keep the glass clean. However, burning un-seasoned wood or burning on lower burn rates leads to dirtier glass (especially on the sides). Do not clean glass with abrasive cleaners. Allow the stove to fully cool before cleaning.

Apply glass cleaner or soapy water to the inside of the glass. Wipe with newspaper or a paper towel to clean. For stubborn creosote, dip a moist paper towel or newspaper in cold ash before cleaning. The ash acts as a mild abrasive.

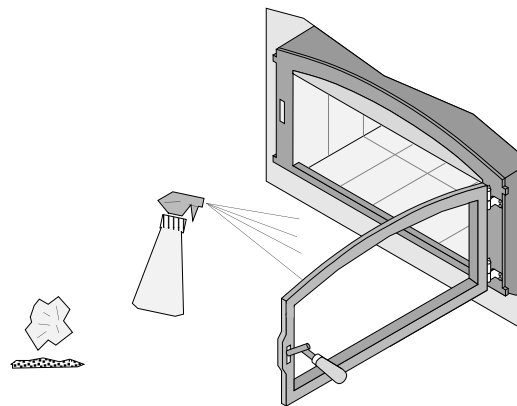

The glass will develop a very slight haze over time. This is normal and will not affect viewing of the fire.

### Monthly Maintenance (while appliance is in use)



Make sure the appliance has fully cooled prior to conducting service.

### Door and Glass Inspection



The door can be lifted off the hinges if extensive repairs are conducted.

The door must form a seal to the firebox for the stove to work correctly. Inspect the door gasket as shown below.

If the glass is damaged, replace it - see "Replacement Parts" for details.

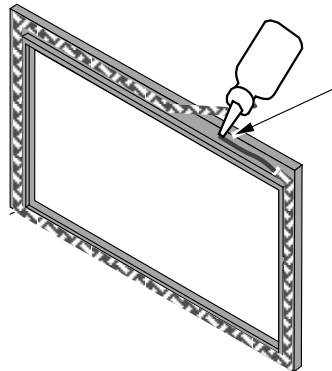

Use RTV high temperature silicone to adhere any loose gasket.

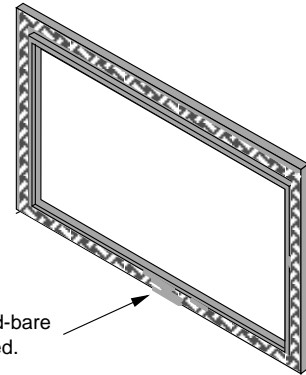

Severely frayed or thread-bare gasket should be replaced.

### Door Latch Adjustment

The door latch should pull the door against the face of the stove (but not so tight as to not allow full handle rotation). If the latch requires adjustment, follow the directions below.

Remove the face. Loosen the bottom nut with a 7/16" wrench (see arrow to the right). Tap the bottom nut inwards, moving the door catch inwards. Tighten the nut and test operation. You may need to repeat this process, either moving the nut inwards or outwards, until the door catch is in the correct position.



Door Handle

### Creosote - Formation and Need for Removal

When wood is burned slowly, it produces tar and other organic vapors, which combine with expelled moisture to form creosote. The creosote vapors condense in the relatively cool chimney flue of a slow-burning fire. As a result, creosote residue accumulates on the flue lining. When ignited, this creosote makes an extremely hot fire. The chimney and chimney connector should be inspected at least once every two months during the heating season to determine if a creosote buildup has occurred. If creosote has accumulated, it should be removed to reduce the risk of a chimney fire.



If you are not certain of creosote inspection, contact your dealer or local chimney sweep for a full inspection. Excess creosote buildup may cause a chimney fire, that may result in property damage, injury, or death.



Operating this appliance continually at a low burn rate (air starvation) or using green (un-seasoned) wood will increase the formation of creosote.

## Yearly Maintenance



Make sure the appliance has fully cooled prior to conducting service.

### Touch Up Paint

Included with the owner's pack of this appliance is a can of Stove-Brite® paint. To touch up nicks or dulled paint, apply the paint while the appliance is cool. Sand rusted or damaged areas before preparation (use 120 grit sandpaper). Clean and dry the area to prepare the surface. Wait at least one hour before starting the appliance. The touched up area will appear darker than the surrounding paint until it cures from heat. Curing will give off some fumes while curing – open windows to ventilate.

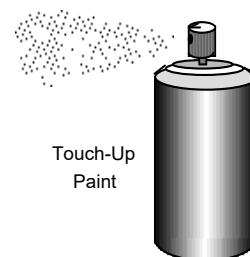

### Cleaning the Air Duct and Blower (if applicable)

Use a vacuum to clean the air ducts (channels). This prevents dust from burning and creating odors. The blower should be vacuumed every year to remove any buildup of dust, lint, etc.

Remove the face. Use a vacuum cleaner to remove any debris or dust in the convection chamber or near the blower (WARNING: do not touch the blower blades).

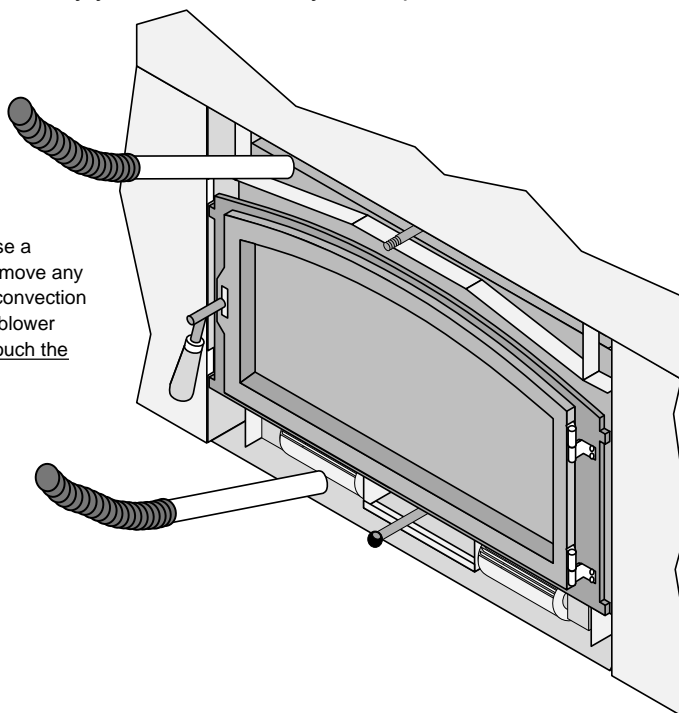

### Firebrick and Baffle Inspection

Use the illustration on page 28 as a reference for checking the following items. Make sure the appliance is cool before proceeding.

Baffle - check the baffle plate and bricks along the ceiling of the firebox to make sure they are intact. Check the bypass assembly.

Secondary Air Tubes - Check the air tubes and collars to make sure they are intact and not severely deteriorated. Slight scaling or rusting of the metal is normal. Make sure the air tubes are secured correctly.

Floor and Wall Firebricks - replace any severely damaged firebrick along the side or floor of the firebox.

Door Parts

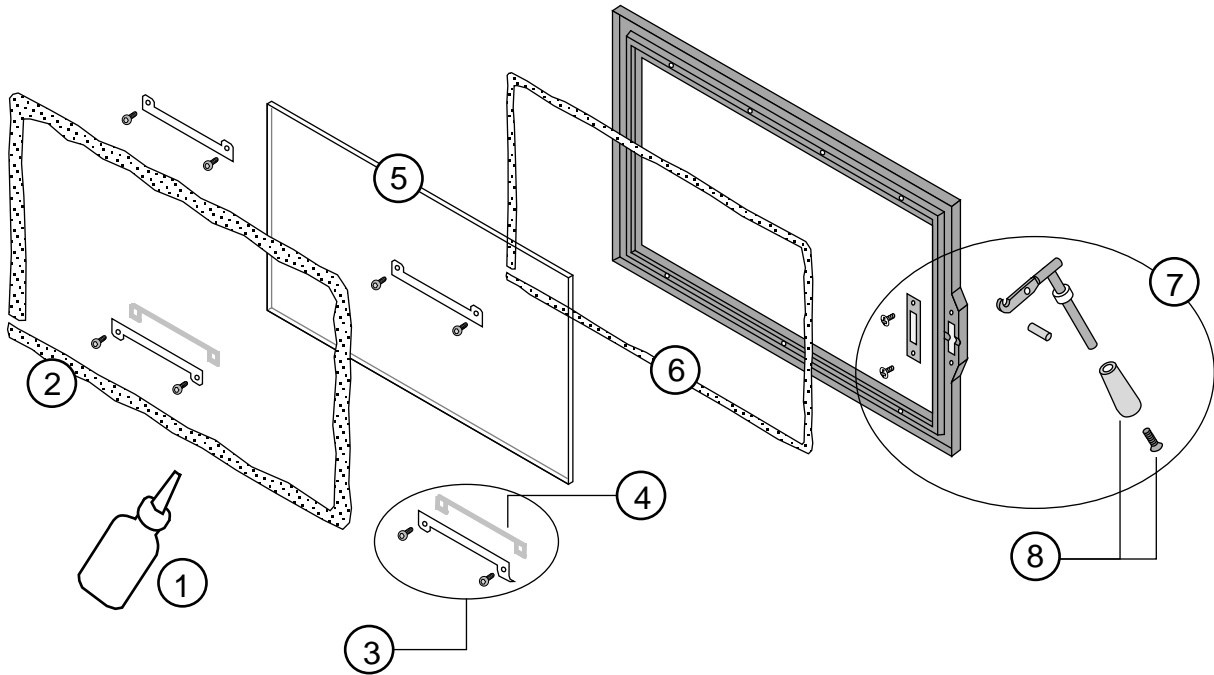

ID #	Description	Qty	Part #	ID #	Description	Qty	Part #
1	Gasket Cement, 4 oz	1	99900427	2	Door Gasket, 3/8" x 70"	1	99900429
3	(4) Clips w Screws, Gaskets - Rect	1	250-02191	4	(2) Clip Gaskets	1	250-02194
	(4) Clips w Screws, Gaskets - Arched	1	250-02193				
5	Glass (w Gasket) - Rectangle	1	250-02183	6	Glass Gasket (1/4" X 65")	1	250-02184
	Glass (w Gasket) - Arched	1	250-02195				
7	Handle Assembly	1	250-02196	8	Wood Handle w Screw	1	250-01305

Replacing the Glass



The glass must not contact the door retainer or glass clips directly. The glass gasket and glass clip gaskets insulate the glass to prevent cracking. Do not over-tighten the glass clips.

Lay the glass gasket in the door frame (cut off excess gasket). Place the glass on the gasket. Secure the glass clips to hold the glass in place (make sure the glass clip gaskets are in place).

Replacing the Door Gasket

The door gasket inserts into the outer groove of the door retainer. Stove gasket cement holds it in place. Before installing, remove any residual cement. Lay the gasket in place (start at the lower left corner) and cut off any excess gasket (do not stretch the gasket. The cement fully cures with heat from the stove. You may need to open and close the door repeatedly to get the gasket to seat fully.

Blower and Electrical Parts

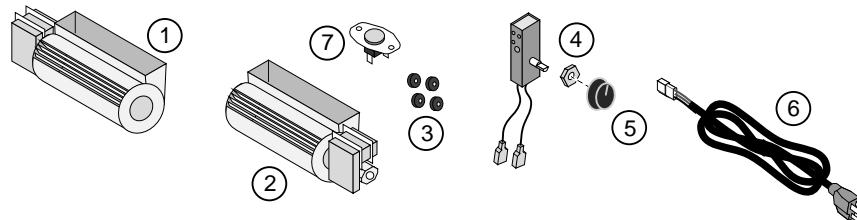

ID #	Description	Qty	Part #	ID #	Description	Qty	Part #
1	Left Blower	1	228-10069	2	Right Blower	1	228-10070
3	(4) Blower Grommets w Spacers	1	250-00369	4	Rheostat	1	250-00302
5	Rheostat Knob w Nut	1	250-00869	6	Power Cord	1	250-00316
7	Thermodisk	1	228-30050				

## Firebox Parts

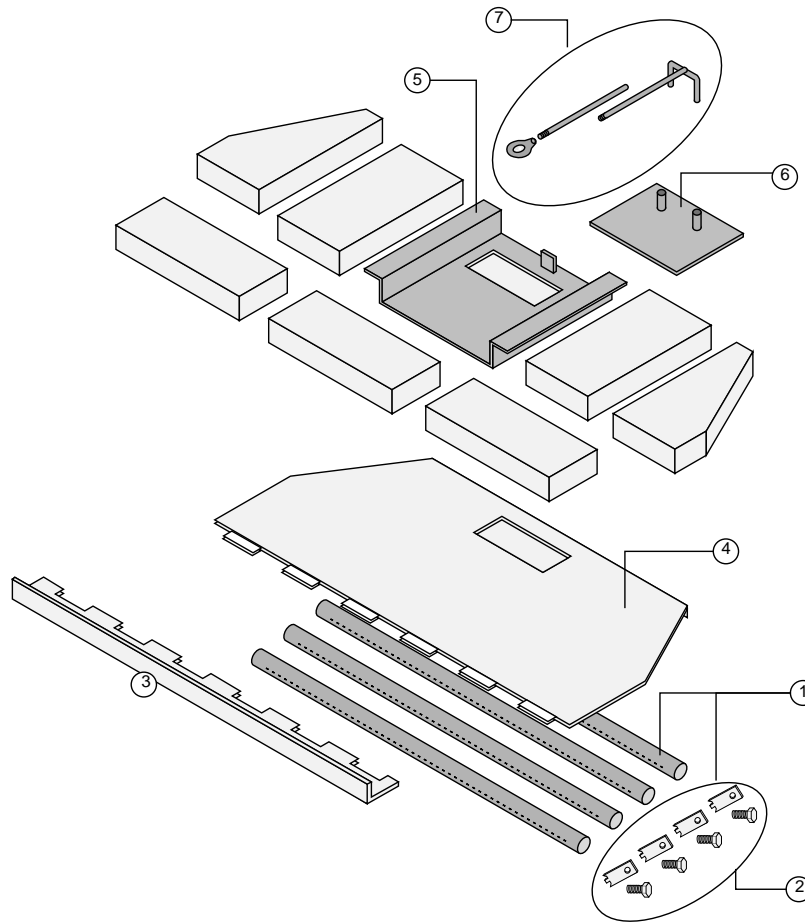

### Baffle Parts

ID #	Description	Qty	Part #	ID #	Description	Qty	Part #
1	Sec. Air Tubes w Pins (all 4) L-24	1	98900243	2	Air Tube Pin (w Screw)	4	250-02186
3	Baffle Front	1	250-02187	4	Baffle Plate	1	250-02188
5	Bypass Plate	1	221-12120	6	Bypass Slider	1	221-12122
7	Damper Yoke	1	250-02189			1	

### Baffle Removal

- 1 Remove the face to prevent damage. Remove the door (lift off hinges).
- 2 Remove the front two air tubes (see "Air Tube Removal & Replacement" on the following page).
- 3 Remove front row of bricks.
- 4 Unscrew the damper rod extension from damper yoke and slide it forward to remove (you may need to use pliers to unscrew the rod).
- 5 Lift the damper yoke up to disengage it from the damper plate. The yoke may be left in place or unscrewed and removed if needed.
- 6 Remove the bypass plate and damper assembly by pulling forward and leaning the front edge down.
- 7 Remove the four rear bricks.
- 8 Remove baffle front and baffle plate (rotate it forward).

***Air Tube Removal & Replacement***

VIEW FROM THE FRONT

VIEW FROM THE REAR

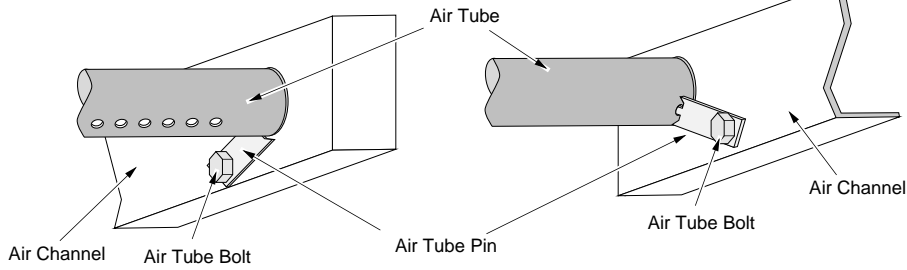

**AIR TUBE REMOVAL**

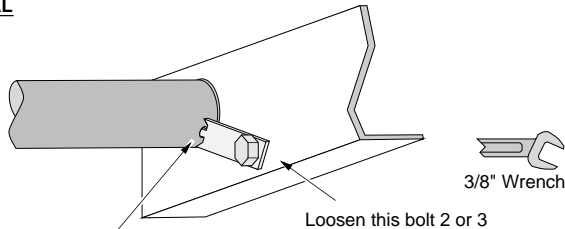

Note how the center of the air tube pin inserts into a hole on the air tube. Loosen this bolt 2 or 3 turns (do not remove).

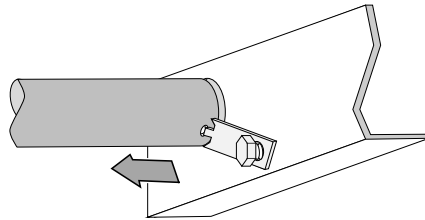

With the bolt loosened the air tube can be slid out of the air channel.

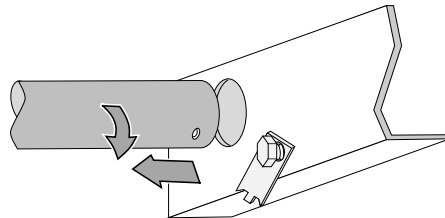

The pin will then disengage from the air tube (you may wish to rotate the tube slightly).

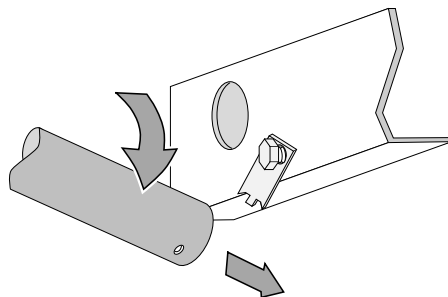

Pivot the air tube downwards and slide it out of the air channel on the opposite side.

**TUBE SIZING**

Front Tube = 25-7/8"

Second Tube = 25-7/8"

Third Tube = 22-5/8"

Back Tube = 19-3/8"

## Brick Removal & Replacement

### Baffle Brick

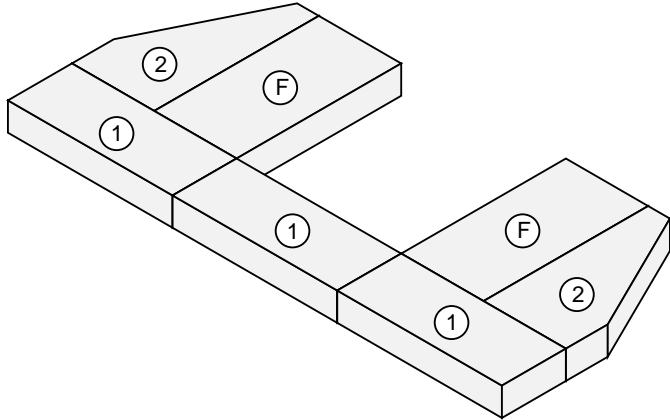

### Floor and Side Brick

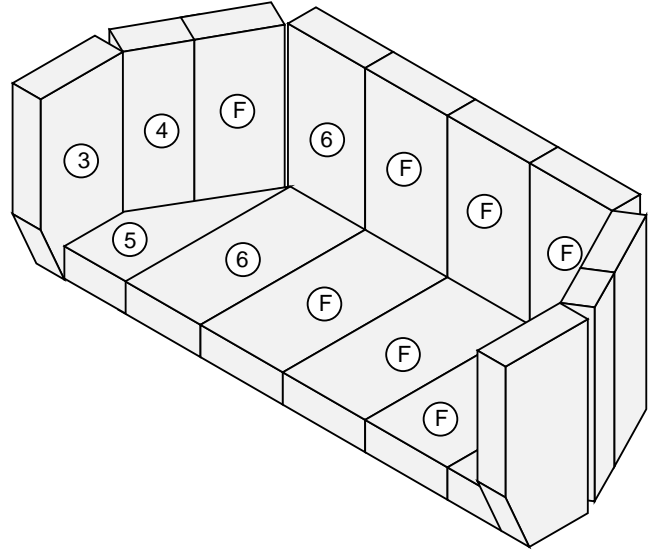

NOTE: "F" Denotes Full Size Brick (4-1/2" x 9")

ID #	Description	Qty	Part #	ID #	Description	Qty	Part #
1	Brick – Cut 9" x 2.75"	3	251-00068	2	Brick – Cut 9" x 4.5" x 2.375"	2	251-00064
3	Brick – Cut 9" x 4.5" x 2.34"	2	251-00067	4	Brick – Cut 9" x 2.75"	2	251-00068
5	Brick – Cut 8" x 3.5" x 2.125"	2	251-00066	6	Brick – Cut 9" x 3.5"	2	251-00015
F	Brick – Full Size 9" x 4.5"	10	251-00000				



**Do not pry the brick - they chip and crack easily.**

Remove the floor bricks first. The side bricks are pinned in place by the floor firebrick. Clean the firebox prior to replacing the brick.

Refer to the section "Baffle Removal" on page 29 for details on removing the baffle bricks.

Register your TRAVIS INDUSTRIES, INC. Limited 7 Year Warranty online at [traviswarranty.com](http://traviswarranty.com). TRAVIS INDUSTRIES, INC. warrants this gas appliance (appliance is defined as the equipment manufactured by Travis Industries, Inc.) to be defect-free in material and workmanship to the original purchaser from the date of purchase as follows:

Check with your dealer in advance for any costs to you when arranging a warranty call. Mileage or service charges are not covered by this warranty. This charge can vary from store to store.

### Years 1 & 2 - COVERAGE: PARTS & LABOR

- **Firebox Assembly:**  
Firebox, Baffle Supports, Air Tubes, Air Channels, Convection Chamber
- **Door Assembly:**  
Cast Door, Latch Assembly, Glass Retainers
- **Air Control Assembly**  
Slider Plate, Pressure Plate
- **Ceramic Glass**  
Glass (breakage from thermal shock)
- **Firebrick**  
Breakage from thermal shock
- **Accessories**  
Legs, Pedestal, Blower
- **Re-Installation Allowance**  
In cases where heater must be removed from home for repairs, a partial cost of re-installation is covered (pre-authorization required)
- **One-Way Freight Allowance**  
One-way freight allowance on pre-authorized repair done at factory is covered.

**Exclusions:** Paint, Gasketing

### Years 3 THROUGH 5 - COVERAGE: PARTS & LABOR

- **Firebox Assembly:**  
Firebox, Baffle Supports, Air Tubes, Air Channels, Convection Chamber
- **Air Control Assembly**  
Slider Plate, Pressure Plate
- **Door Assembly:**  
Cast Door, Latch Assembly, Glass Retainers
- **One-Way Freight Allowance**  
One-way freight allowance on pre-authorized repair done at factory is covered.

**Exclusions:** Paint, Gasketing, Accessories (Legs, Pedestal, Panels, Blower), Glass, Firebrick, Re-Installation Allowance

### Years 6 THROUGH 7 - COVERAGE: PARTS

- **Firebox Assembly:**  
Firebox, Baffle Supports, Air Tubes, Air Channels, Convection Chamber
- **Air Control Assembly**  
Slider Plate, Pressure Plate
- **Door Assembly:**  
Cast Door, Latch Assembly, Glass Retainers

**Exclusions:** Paint, Gasketing, Accessories (Legs, Pedestal, Panels, Blower), Glass, Firebrick, Re-Installation Allowance, One-Way Freight Allowance, Labor Charges

## CONDITIONS & EXCLUSIONS

1. This new appliance must be installed by a qualified installer. It must be installed, operated, and maintained at all times in accordance with the instructions in the Owner's Manual. Any alteration, willful abuse, accident, neglect, or misuse of the product shall nullify this warranty.
2. This warranty is nontransferable, and is made to the ORIGINAL purchaser, provided that the purchase was made through an authorized Travis dealer.
3. Discoloration and some minor expansion, contraction, or movement of certain parts and resulting noise, is normal and not a defect and, therefore, not covered under warranty.
4. This warranty does not cover misuse of the stove. Misuse includes over-firing (operation where the connector or stove may glow red) of this appliance can cause serious damage and will nullify this warranty. Misuse includes use of salt saturated wood, chemically treated wood, or any fuel not recommended in the manual.
5. Damage to the stove due to improper break-in procedures (see manual for proper break in).
6. The salt air environment of coastal areas or a high humidity environment can be corrosive to the castings. These conditions can be corrosive and can cause the cast iron to rust. This warranty does not cover any damage caused by a salt air or high humidity environment.
7. Damage to the appliance while it is in transit is not covered by this warranty, but is subject to a claim against the common carrier.
8. The warranty, as outlined within this document, does not apply to the chimney components or other Non-Travis accessories used in conjunction with the installation of this product. If in doubt as to the extent of this warranty, contact your authorized Travis retailer before installation.
9. Travis Industries will not be responsible for inadequate performance caused by environmental conditions such as nearby trees, buildings, roof tops, wind, hills or mountains or negative pressure or other influences from mechanical systems such as furnaces, fans, clothes dryers, etc.
10. This Warranty is void if:
  - a. The appliance has been operated in atmospheres contaminated by chlorine, fluorine or other damaging chemicals.
  - b. The appliance is subject to submersion in water or prolonged periods of dampness or condensation.
  - c. Any damage to the appliance, combustion chamber, heat exchanger or other components due to water, or weather damage which is the result of, but not limited to, improper chimney/venting installation.
11. Exclusions to this Warranty include: injury, loss of use, damage, failure to function due to accident, negligence, misuse, improper installation, alteration or adjustment of the manufacturer's settings of components, lack of proper and regular maintenance, damage incurred while the appliance is in transit, alteration, or act of God.
12. This warranty excludes damage caused by normal wear and tear, such as paint discoloration or chipping, worn or torn gasketing, chipped or cracked firebrick, etc. Also excluded is damage to the appliance caused by abuse, improper installation, modification of the appliance, or the use of fuel other than that for which the appliance is configured (use cord wood only).
13. Damage to brass or plated surfaces caused by fingerprints, scratches, melted items, or other external sources left on the surfaces from the use of abrasive cleaners is not covered in this warranty. Damage to the surfaces from over-firing (operation where the steel may glow red) is not covered in this warranty.
14. TRAVIS INDUSTRIES, INC. is free of liability for any damages caused by the appliance, as well as inconvenience expenses and materials. Incidental or consequential damages are not covered by this warranty. In some states, the exclusion of incidental or consequential damage may not apply.
15. This warranty does not cover any loss or damage incurred by the use or removal of any component or apparatus to or from the Travis appliance without the express written permission of TRAVIS INDUSTRIES, INC. and bearing a TRAVIS INDUSTRIES, INC. label of approval. This warranty does not cover a stove repaired by someone other than a Travis Industries authorized dealer.
16. Any statement or representation of Travis products and their performance contained in Travis advertising, packaging literature, or printed material is not part of this warranty.
17. This warranty is automatically voided if the appliance's serial number has been removed or altered in any way. If the appliance is used for commercial purposes, it is excluded from this warranty.
18. No dealer, distributor, or similar person has the authority to represent or warrant Travis products beyond the terms contained within this warranty. TRAVIS INDUSTRIES, INC. assumes no liability for such warranties or representations.
19. Travis Industries will not cover the cost of the removal or re-installation of hearths, facing, mantels, venting or other components.
20. If for any reason any section of this warranty is declared invalid, the balance of the warranty remains in effect and all other clauses shall remain in effect.
21. This warranty is the only warranty supplied by Travis Industries, Inc., the manufacturer of the appliance. All other warranties, whether express or implied, are hereby expressly disclaimed and purchaser's recourse is expressly limited to the warranties set forth herein.

## IF WARRANTY SERVICE IS NEEDED:

1. If you discover a problem that you believe is covered by this warranty, you MUST REPORT it to your Travis dealer WITHIN 30 DAYS, giving them proof of purchase, the purchase date, and the model name and serial number.
2. Travis Industries has the option of either repairing or replacing the defective component.
3. If your dealer is unable to repair your appliance's defect, he may process a warranty claim through TRAVIS INDUSTRIES, INC., including the name of the dealership where you purchased the appliance, a copy of your receipt showing the date of the appliance's purchase, and the serial number on your appliance. At that time, you may be asked to ship your appliance, freight charges prepaid, to TRAVIS INDUSTRIES, INC. TRAVIS INDUSTRIES, INC., at its option, will repair or replace, free of charge, your appliance if it is found to be defective in material or workmanship within the time frame stated within this warranty. TRAVIS INDUSTRIES, INC. will return your appliance, freight charges (years 1 to 3) prepaid by TRAVIS INDUSTRIES, INC., to your regional distributor, or dealership.
4. Check with your dealer in advance for any costs to you when arranging a warranty call. Mileage or service charges are not covered by this warranty. This charge can vary from store to store.
5. Any appliance or part thereof that is repaired or replaced during the limited warranty period will be warranted under the terms of the limited warranty for a period not to exceed the remaining term of the original limited warranty or six(6) months, whichever is longer.

Listing Label

**DO NOT REMOVE THIS LABEL**

CONTACT LOCAL BUILDING OR FIRE OFFICIALS ABOUT INSTALLATION AND RESTRICTIONS IN YOUR AREA.  
SUITABLE FOR USE IN FACTORY-BUILT (Z.C.) FIREPLACES AND MASONRY FIREPLACES.



Intertek  
Report No. 100289794PRT-001  
Control No. 4000515

MODEL:

**FLUSH WOOD PLUS**

Certified for USA and Canada

SERIAL NO:



CONFORMS TO UL STD 1482; CERTIFIED TO ULC STD S628-1993

**FACTORY-BUILT (Z.C.) FIREPLACE OR MASONRY FIREPLACE INSTALLATION**

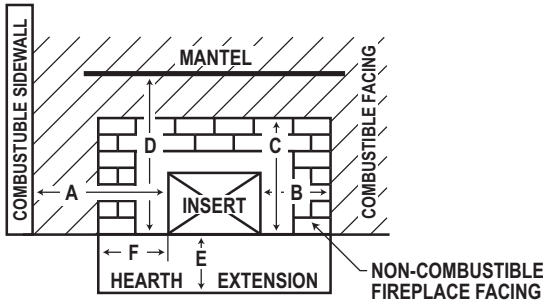

Minimum Clearance to Combustibles and Hearth Requirements	Masonry Fireplace Installations	Factory-Built (Z.C.) Fireplace Installations
A.	9 in. / 229 mm	9 in. / 229 mm
B.	9 in. / 229 mm	9 in. / 229 mm
*C.	39 in. / 991 mm	39 in. / 991 mm
D.	41.5 in. / 1055 mm	41.5 in. / 1055 mm
*E. (US)	16 in. / 407 mm	16 in. / 407 mm
*E. (CAN)	18 in. / 458 mm	18 in. / 458 mm
F. (US)	6 in. / 153 mm	6 in. / 153 mm
F. (CAN)	8 in. / 204 mm	8 in. / 204 mm

\* From the base of Fireplace Insert.

Factory-Built (Z.C.) Fireplace installations require a fireplace chimney full re-line. Factory-Built (Z.C.) Fireplace chimney must have a minimum cross-sectional area of 28.85 square inches / 733 square mm. A non-combustible hearth floor protection is also required that provides a thermal resistance with an R value equal to 2.38 or greater (see chart above and / or owner's manual for required sizing details).

Minimum 6 in. / 153 mm diameter Stainless Steel liner, full re-line required.

In Canada; a fireplace insert shall be installed with a continuous chimney liner extending from the fireplace insert to the top of the chimney. A chimney liner shall be tested for conformance with Class 3 requirements of CAN/ULC-S635, Standard for Lining Systems for Existing Masonry or Factory-Built Chimneys and Vents, or CAN/ULC-S640, Standard for Lining Systems for New Masonry Chimneys.

**PREVENT HOUSE FIRES** - Install and use only in accordance with the manufacturer's installation and operating instructions. Contact your local building or fire officials about restrictions and installation inspection in your area. Do not connect this unit to a chimney flue serving another appliance.

Electrical Rating: 115V, 60 Hz, 1.8 Amps  
Blowers: # 228-10069 / 228-10070  
Do not route power cord under or in front of appliance.  
Replace glass only with 5mm neoceramic or ceramic glass.



**TRAVIS INDUSTRIES  
HOUSE OF FIRE**

Manufactured by:  
TRAVIS INDUSTRIES, INC.  
12521 Harbour Reach Drive  
Mukilteo, WA 98275  
www.travisproducts.com

U.S. ENVIRONMENTAL PROTECTION AGENCY

Certified to comply with 2015 particulate emission standards. Not approved for sale after May 15, 2020. 4.4 g/h, Method 28, 5G1, 2015

DATE OF MANUFACTURE

Made in U.S.A.    2015   2016   2017   2018   Jan   Feb   Mar   Apr   May   Jun   Jul   Aug   Sep   Oct   Nov   Dec

0921



Air Control .....	19	Sounds (Normal Operating Sounds) .....	21
Air Tube Part Number .....	28	Starting a Fire.....	17
Air Tube Removal & Replacement .....	30	Stove Does Not Burn Long Enough .....	23
Ash Disposal .....	25	Stove is Not Hot Enough (Troubleshooting).....	23
Baffle Parts .....	28	Table of Contents.....	3
Baffle Removal and Replacement .....	29	Touch-Up Paint .....	27
Blower Cleaning .....	27	Troubleshooting (Operation) .....	23
Blower Does Not Run (Troubleshooting).....	23	Warranty Card.....	2
Blower Operation (optional).....	21	Warranty.....	32
Burn Rate .....	19	Wood.....	22
Chimney Cleaning .....	26	Yearly Maintenance.....	27
Chimney Inspection (Creosote).....	26		
Chimney Requirements.....	11		
Cleaning the Ash.....	25		
Cleaning the Glass .....	25		
Clearances .....	9		
Creosote Check .....	26		
Daily Maintenance.....	25		
Dimensions .....	6		
Door and Glass Inspection .....	26		
Door Assembly.....	28		
Door Gasket Replacement.....	28		
Door Opening.....	15		
Door Parts .....	28		
Draft Performance .....	10		
Elbows (Chimney) .....	6		
Emissions.....	6		
EPA Approval.....	6		
Features.....	6		
Fire Starting.....	17		
Firebox Assembly.....	28		
Firebox Parts.....	28		
Firebrick and Baffle Inspection .....	27		
Firebrick Removal & Replacement.....	31		
Floor Protection Requirements (Hearth).....	9		
Glass Cleaning .....	25		
Glass Replacement.....	28		
Hearth Requirements .....	9		
Heating Specifications.....	6		
Hints for Burns .....	22		
Installation Options.....	6		
Listing Label .....	34		
Maintenance.....	25		
Monthly Maintenance .....	26		
Noise (Normal Operating Sounds) .....	21		
Opening the Door .....	15		
Operation .....	7		
Over-Firing the Stove .....	15		
Overnight Burn .....	21		
Paint (Touch-Up Paint).....	27		
Paint Curing .....	15		
Re-Loading the Stove .....	21		
Safety Label .....	34		
Safety Precautions .....	4		
Smell (from paint curing) .....	15		
Smoke Enters Room (Troubleshooting).....	23		