

M A N U A L

VISIO

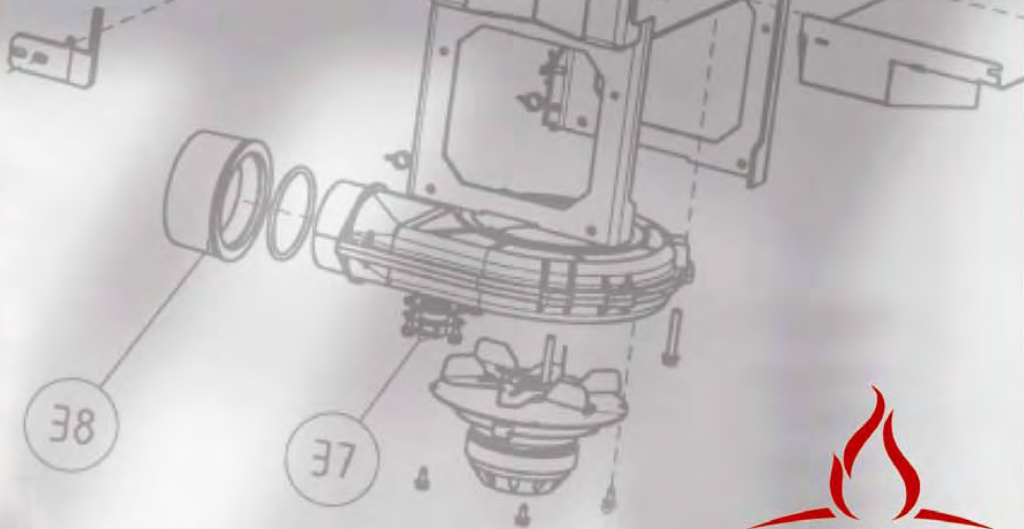

TABLE OF CONTENTS

INSTALLATION AND ASSEMBLY

RIKA: An Overview	3
Safety Precautions	4
Labels	6
Main Control Board/Specifications	7
Parts Illustration	8
Automatic Safety Functions	12
Installation Instructions	13
Mobile Home Installation	16

A New Heating Philosophy	17
--------------------------	----

PELLETS / GENERAL

What Are Pellets?	18
Storing Pellets	19

OPERATING INSTRUCTIONS / FEATURES

Basic Operation	20
Starting / Programming Control	21

MAINTENANCE AND CLEANING

Maintenance and Cleaning	23
Trouble Shooting	27

MISCELLANEOUS

Control Flowchart	29
Key Word Abbreviations	30
User Notes	31

WARRANTY

Warranty	32
Warranty Registration Card	33

SAFETY NOTICE

IF THIS WOOD PELLET STOVE IS NOT PROPERLY INSTALLED, A HOUSE FIRE MAY RESULT.

FOR YOUR SAFETY, FOLLOW THE INSTALLATION DIRECTIONS.

CONTACT LOCAL BUILDING OR FIRE OFFICIALS ABOUT RESTRICTIONS AND INSTALLATION INSPECTION REQUIREMENTS IN YOUR AREA.

PLEASE READ THIS ENTIRE MANUAL BEFORE INSTALLATION AND USE OF THIS WOOD PELLET FUEL-BURNING ROOM HEATER. FAILURE TO FOLLOW THESE INSTRUCTIONS COULD RESULT IN PROPERTY DAMAGE, BODILY INJURY OR EVEN DEATH.

SAVE THESE INSTRUCTIONS FOR FUTURE REFERENCE

WARNING

THIS STOVE IS NOT INTENDED FOR USE IN COMMERCIAL APPLICATIONS.

THIS STOVE SHOULD BE INSTALLED BY AN AUTHORIZED SERVICE TECHNICIAN.

RIKA: AN OVERVIEW

Portrait

Congratulations on your purchase of a quality RIKA wood pellet stove made by Rika. You are now a member of a group of more than 100,000 Rika owners. If you were not familiar with Rika before your purchase, please allow us to introduce ourselves:

Rika was founded more than 50 years ago in Micheldorf, Austria by Karl Riener and his family. From a small company, specializing in hand made wrought iron products, grew a large, well known company recognized today as Rika Metallwarengesellschaft. We appreciate quality and feel that our company manufactures some of the finest pellet and wood burning stoves available in today's marketplace.

Unique designs and emphasis on quality, performance and superior workmanship have made us a leading stove manufacturer in Europe. State of the art processes, such as; robotic welding, laser cutting and complete micro-processor control systems, allow us to produce a final product that we feel is unequalled.

In addition to pellet stoves, we are also known for our high quality wood-burning stoves, wood-burning cook stoves, freestanding fireplaces, and water heater units. Rika also produces a large variety of other metal products for international corporations.

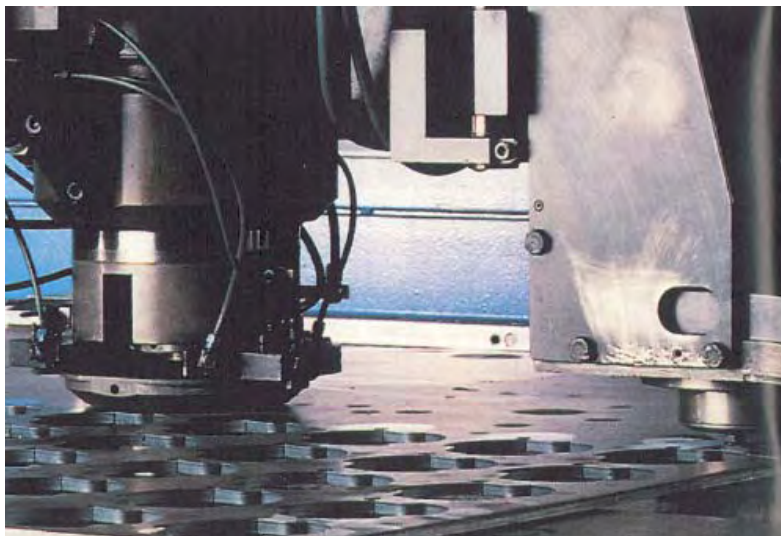

In 1988, Rika began to introduce its products into the United States under the trade name RIKA. Rapid growth in the U.S. is directly attributed to the quality and unique design of the RIKA line of pellet stoves. Attention to detail has given us the nickname in the United States as the "Mercedes of the Pellet Stove Industry".

SAFETY PRECAUTIONS

READ THESE SAFETY PRECAUTIONS BEFORE INSTALLING OR USING STOVE

The RIKA VISIO freestanding wood pellet stove must be properly installed in order to prevent the possibility of a house fire. For your own safety, you must adhere strictly to the installation instructions. Contact your local building officials to obtain a permit and information on any installation restrictions and inspection requirement in your area. Failure to follow these instructions could result in property damage, bodily injury or even death.

The word “stove”, as used in this manual, means the Visio Freestanding wood pellet stove.

The stove’s exhaust system works with negative combustion chamber pressure and a slightly positive chimney pressure. It’s crucial that the air intake and exhaust system are air tight and installed correctly.

WARNING

BURN WOOD PELLET FUEL ONLY! NEVER BURN ANY OTHER FUEL SUCH AS PAPER, SOLID WOOD OR CHARCOAL!

When operated properly, the stove cannot be over heated. However, continuous operation at maximum burn may shorten the life of the electrical components and is not recommended.

Do not use gasoline, gasoline-type lantern fuel, kerosene, charcoal lighter fluid or similar liquids to start or “freshen up” a fire in this stove. Keep these flammable liquids well away from this stove when it is in use.



Build-up of dust, soot, or creosote in the chimney connector and in the exhaust vent can cause a house fire. Although buildup will be minimal with correct operation, it is advisable to inspect the chimney connector and exhaust vent on a regular basis, and clean if necessary, at least once per heating season.

NOTE: Disconnect power before performing any maintenance or cleaning on your stove.

DISPOSAL OF ASHES

Ashes removed from the stove may be hot. Ash must be placed in a metal container with a tight fitting lid. The closed container of ashes should be placed on a noncombustible floor or on the ground, well away from all combustible materials, pending final disposal. If the ashes are disposed of by burial in soil or otherwise locally dispersed, they should be retained in the closed container until all cinders have been thoroughly cooled.

This stove comes with a 7' to 8' grounded electrical cord. This cord should be connected to a standard, properly polarized, 110volt, 60hz electrical outlet. The approximate power requirement is 110 volt. The power supply cord must be routed to avoid contact with any of the hot or sharp exterior surface areas of the stove. In addition, all Austroflamm Visio pellet stoves installed in a mobile home, must be electrically grounded to the steel chassis of the home and bolted to the floor in compliance with and according to H.U.D. requirements. It is recommended that a good quality surge suppressor be used in conjunction with your stove.

SAFETY PRECAUTIONS

**HOT WHILE IN OPERATION!
KEEP CHILDREN, CLOTHING AND
FURNITURE AWAY FROM STOVE.
CONTACT WITH STOVE MAY
CAUSE SKIN BURNS.**

**DO NOT COOK FOOD, HOT
BEVERAGES, OR PLACE ANYTHING
ON TOP OF STOVE.**

**DO NOT USE CHEMICALS OR
FLUIDS TO START THE FIRE.**

**DO NOT BURN GARBAGE OR
FLAMMABLE FLUIDS SUCH AS
GASOLINE, NAPHTHA OR ENGINE
OIL.**

SOOT AND FLYASH – FORMATION AND NEED FOR REMOVAL

The products of combustion will contain small particles of flyash. The flyash will collect in the exhaust venting system and restrict the flow of the flue gasses. Incomplete combustion, such as occurs during startup, shutdown, or incorrect operation of the stove will lead to some soot formation which will collect in the exhaust venting system. The exhaust venting system should be inspected at least once every year to determine if cleaning is necessary.

The pellets burned in the stove are fed by an auger. This auger is driven by a high-torque motor. The auger is capable of causing serious injury to fingers. Keep pellets in the hopper at all times.

The auger may start at any time when the stove is running! Keep hands and fingers away from auger at all times as contact with auger may cause personal injury.

DO NOT OPERATE YOUR STOVE WITH THE DOOR OPEN!

Operating your stove with the door open will allow smoke to enter into the room and can cause smoke detectors to activate. Operating your stove with the door open will result in a disruption in the combustion process which may cause your stove to automatically shut down. Operating your stove with the door open can cause a fire.

SAFETY TESTING

The RIKA Visio Pellet Stove has been independently tested and listed with OMNI-Test Laboratories, Inc. in Beaverton, Or., an accredited testing laboratory, in accordance with the specifications and procedures outlined in ASTM E1509 "Standard Specifications for Room Heaters, Pellet Fuel-Burning Type", ULC/ORD C1482, and ULC S627. (The safety listing label is on the back of the stove.)

The stove is designed specifically for use with pelletized fuels only. It is tested and listed for residential installation according to current national and local building codes.

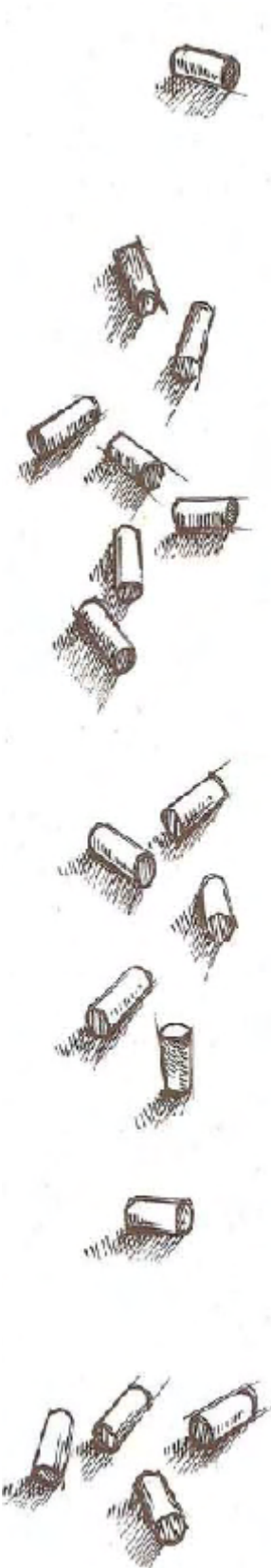

OMNI SAMPLE LABEL FOR VISIO FREE-STANDING PELLET STOVE

AUSTROFLAMM VISIO Manufactured for: Lucky Distributing, Inc. 8111 NE Columbia Blvd. Portland, OR 97218		Tested & Listed By  Beaverton Oregon USA OMNI-Test Laboratories, Inc. Report No. 313-S-04-2	
Model: Visio Tested To: ASTM E 1509-04, ULC C1482 ULC S627 Type Of Fuel: Approved Pellets Only	Serial No. <input type="text"/>	DO NOT REMOVE THIS LABEL Made in Austria	
Date of Manufacture/Date de Fabrication			
2007 2008 2009 Jan Feb Mar Apr May Jun Jul Aug Sep Oct Nov Dec			
<input type="checkbox"/> <input type="checkbox"/> <input type="checkbox"/> <input type="checkbox"/> <input type="checkbox"/> <input type="checkbox"/> <input type="checkbox"/> <input type="checkbox"/> <input type="checkbox"/> <input type="checkbox"/> <input type="checkbox"/> <input type="checkbox"/> <input type="checkbox"/> <input type="checkbox"/> <input type="checkbox"/>			
LUCKY 06-4856			

CONTACT YOUR LOCAL BUILDING OR FIRE OFFICIALS ABOUT RESTRICTIONS AND INSTALLATION INSPECTION IN YOUR AREA
 Listed Room Heaters, Solid Fuel Type
 Also Suitable for Mobile Home Installations Pursuant to (UM) H84-HUD

Configuration: Visio

"PREVENT HOUSE FIRES"

Install and use only in accordance with manufacturer's installation and operating instructions and your local building codes.

CAUTION: Special methods are required when passing chimney through a wall or ceiling, refer to local building codes. Do not connect this unit to a chimney flue serving another appliance.

Inspect and clean exhaust venting system frequently.

Keep viewing and ash removal doors tightly closed during operation.

WARNING: (MOBILE HOME) An outside air inlet must be provided for combustion and be unrestricted while unit is in use. Do not install appliance in a sleeping room.

For use with Pellet Fuel Only

Components Required for Residential Installation: Listed Pellet Vent.

NOTE: Replace glass only with 5 mm ceramic or NEOCERAM.

Electrical Rating: 120 VAC, 60 Hz

DANGER: Risk of electrical shock.

Disconnect power before servicing unit.

Do not route power cord beneath heater.

Components Required for Mobile Home Installation: Outside Air Kit.

INPUT RATING: This pellet fired appliance has been tested and listed for use in manufactured home in accordance with Oregon Administrative Rules 814-23-900 through 814-23-909.

LUCKY DISTRIBUTING
 06-4857

Minimum Clearance to Combustible Materials (in inches and mm)
 Déagagements Minimaux aux Matières Combustibles (pouces et mm)

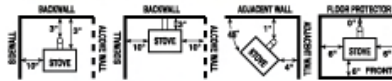

Floor protector must be non-combustible material extending beneath heater and to the front/sides/rear as indicated.
 Le protecteur de sol doit être fait d'un matériau non combustible placé sous le foyer et se prolongeant vers l'avant, l'arrière et les côtés du foyer.

Alcove Dimensions: 53.5" min. height, 41" min. width, and 30" max. depth.
 Dimensions de l'alcôve: Hauteur min. 136cm, largeur min. 104cm, profondeur max. 76cm.

Unit to Sidewall / de l'appareil au mur latéral 10"254 mm

Unit to Backwall / de l'appareil au mur arrière 3"775 mm

Corner of Stove Top to Sidewall 4"7100 mm

Unit to Alcove Ceiling or Mantle 13.5"7943 mm

Unit to Alcove Floor / de l'appareil au plafond d'alcôve ou linteau 13.5"7943 mm

Input Rating / de l'admission nominale 35,600 Btu/hr

SIDEWALL = MUR LATÉRAL
 ADJACENT WALL = MUR ADJACENT
 ALCOVE WALL = MUR D'ALCÔVE
 FRONT = DEVANT
 BACKWALL = MUR ARRIÈRE
 STOVE = POÊLE
 FLOOR PROTECTION = PROTECTION DE SOL

PRENDRE CONTACT AVEC LE BUREAU DE LA CONSTRUCTION LOCAL ET LE SERVICE DES INCENDIES POUR CONNAÎTRE LES RESTRICTIONS ET LES INSPECTIONS REQUISES DANS VOTRE REGION

Répertorié comme appareil de chauffage de pièce à carburant solide Convient aussi aux maisons mobiles conformément au (UM) H84-HUD

"ÉVITEZ LES INCENDIES" N'installez et n'utilisez qu'en suivant les instructions du fabricant concernant l'installation et le fonctionnement ainsi que la réglementation locale de construction.

MISE EN GARDE: Le passage d'une cheminée à travers un mur ou un plafond demande une méthode spéciale d'installation. Consultez les codes de construction et les directives d'installation du fabricant. Ne reliez pas cet appareil au conduit d'un autre appareil.

Inspectez et nettoyez fréquemment le dispositif d'évacuation des gaz.

Maintenez les portes de visualisation et de retrait des cendres complètement fermées pendant le fonctionnement.

AVERTISSEMENT: (MAISON MOBILE) Une admission d'air extérieur de combustion sans obstruction doit être assurée quand l'appareil est en utilisation. N'installez pas l'appareil dans une chambre à coucher.

N'utilisez que des granulés de bois.

Composantes requises pour l'installation résidentielle: Évent répertorié pour les appareils à granulés.

ADMISSION NOMINALE: Cet appareil de chauffage à granulés a été testé et répertorié pour l'usage dans des maisons pré-fabriquées, conformément aux règlements administratifs de l'Oregon 814-23-900 à 814-23-909.

Carburant: Boulettes approuvées seulement.

REMARQUE: Ne remplacez le verre qu'avec une vitre de céramique ou NEOCERAM de 5 mm.

Alimentation Électrique: 120 VAC, 60 Hz.

DANGER: Risque de choc électrique. Couper le courant avant de faire l'entretien. Ne pas activer le cordon sous l'appareil.

Composante requise pour l'installation dans une maison mobile: Assemblage d'air extérieur.

MAIN CONTROL BOARD/SPECIFICATIONS

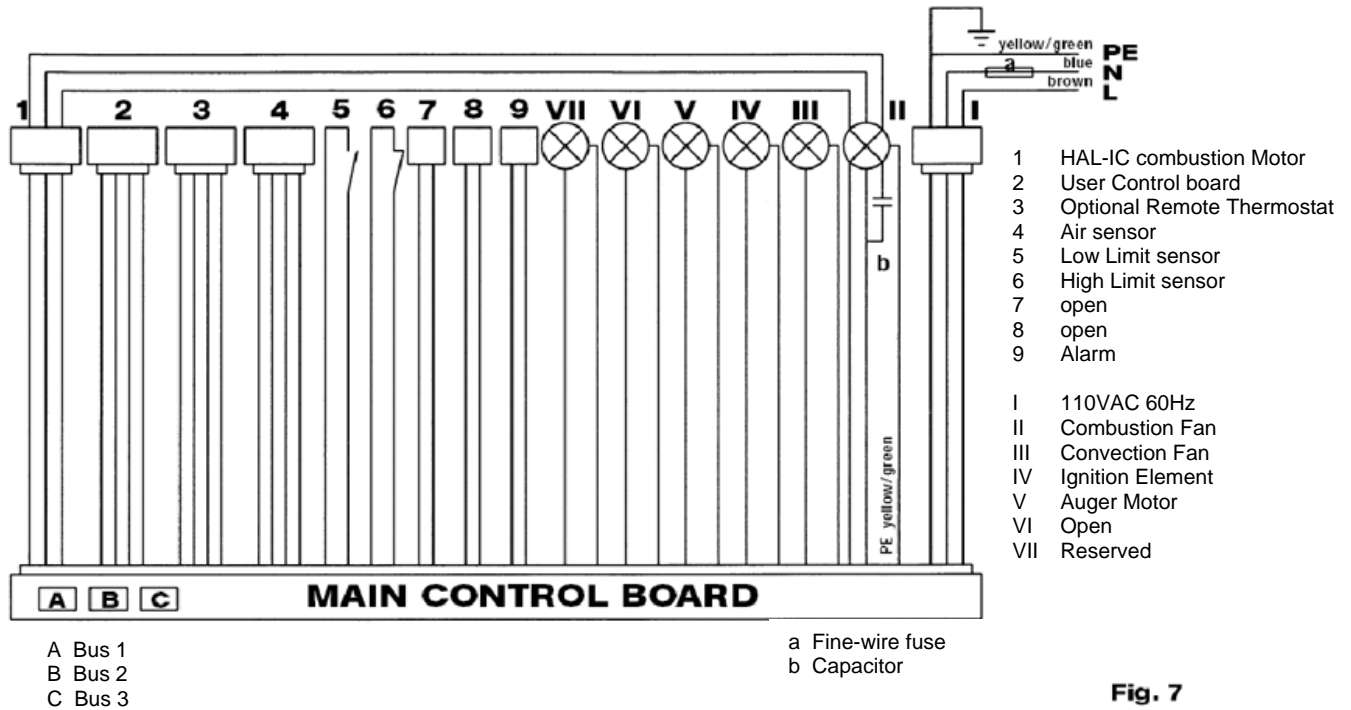
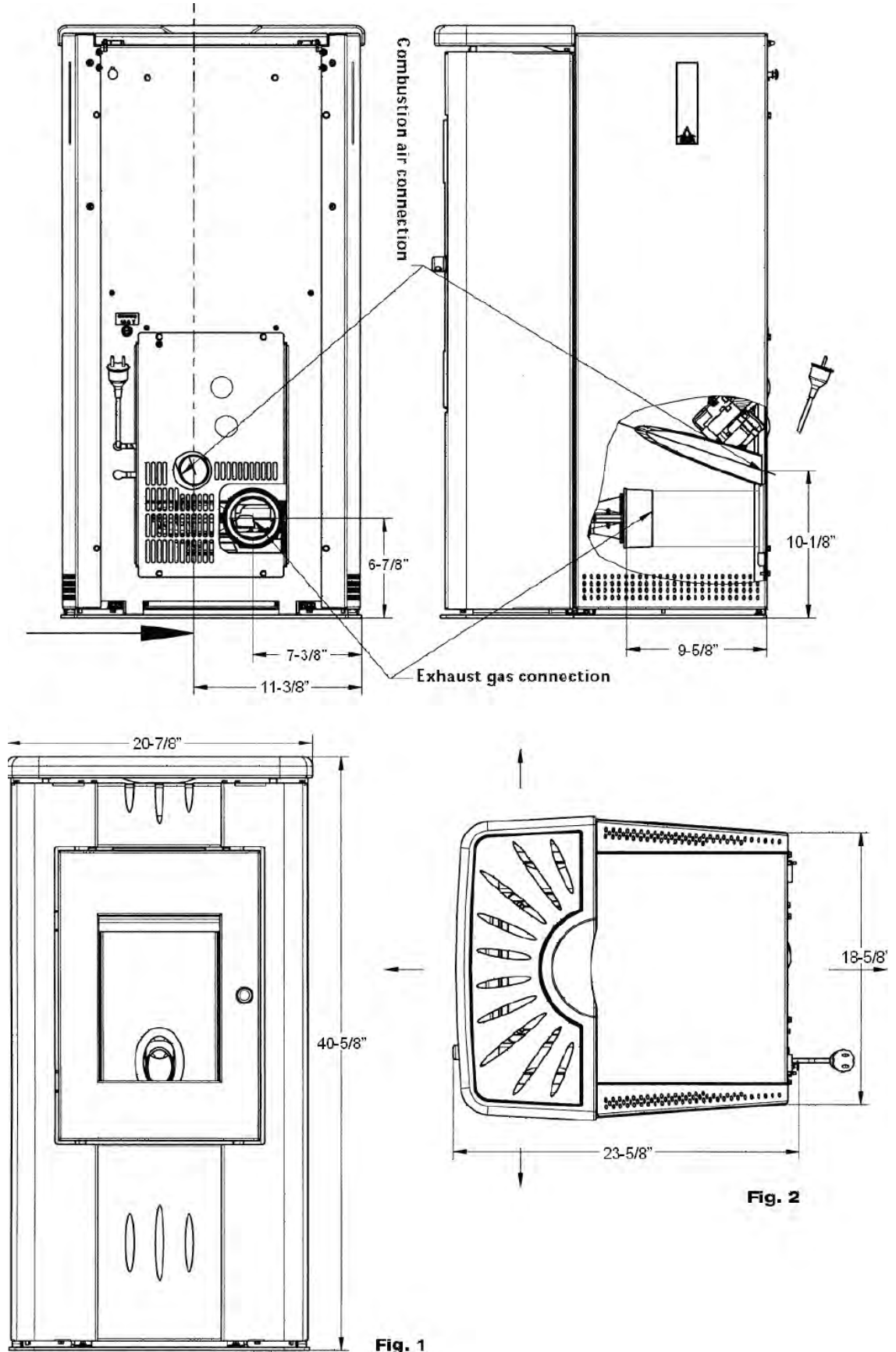

Fig. 7

Specifications & Capacities	
Height (inches)	40-5/8"
Width (inches)	20-7/8"
Depth (inches)	23-5/8"
Weight (lbs)	320
Exhaust Outlet	3"
Heating Capacity	11,000 – 35,600 BTU's
Fuel Consumption	1.5 – 4 lbs/hour
Pellet Hopper Capacity	70.5 lbs
Power Supply	110 V, 60 Hz
Average Electrical Power Consumption	< 100 W
Fuse	3.15 A

PARTS ILLUSTRATION



PARTS ILLUSTRATION

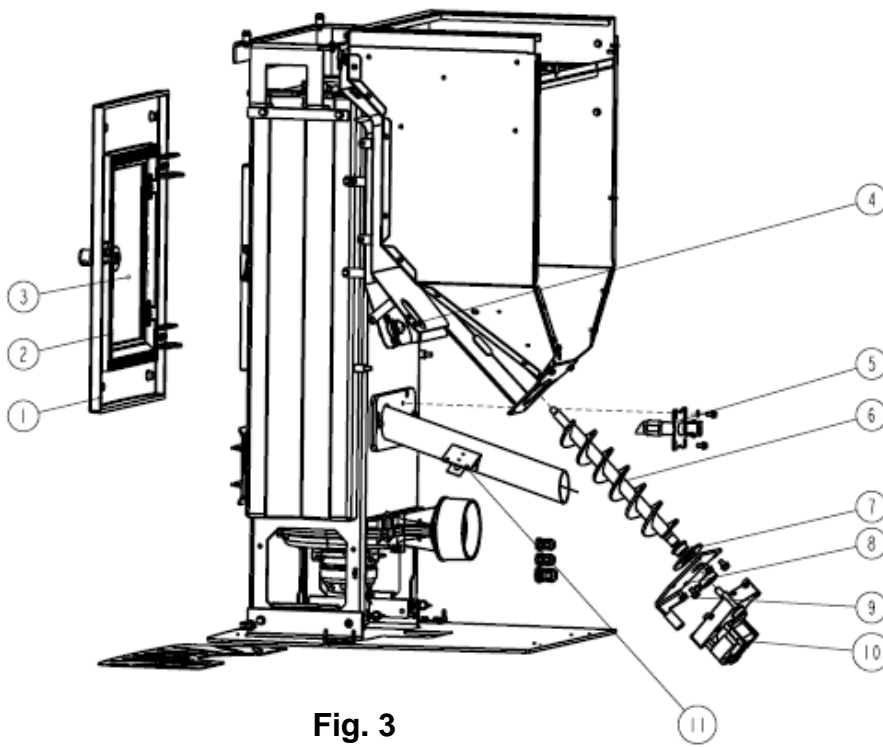

Fig. 3

Figure 3	
01	Combustion door
02	Combustion door seal
03	Combustion door glass
04	Hi-limit switch
05	Ignition element
06	Auger shaft
07	Auger centring plate
08	Auger motor plate
09	Hexagonal bolt
10	Auger motor
11	Air sensor

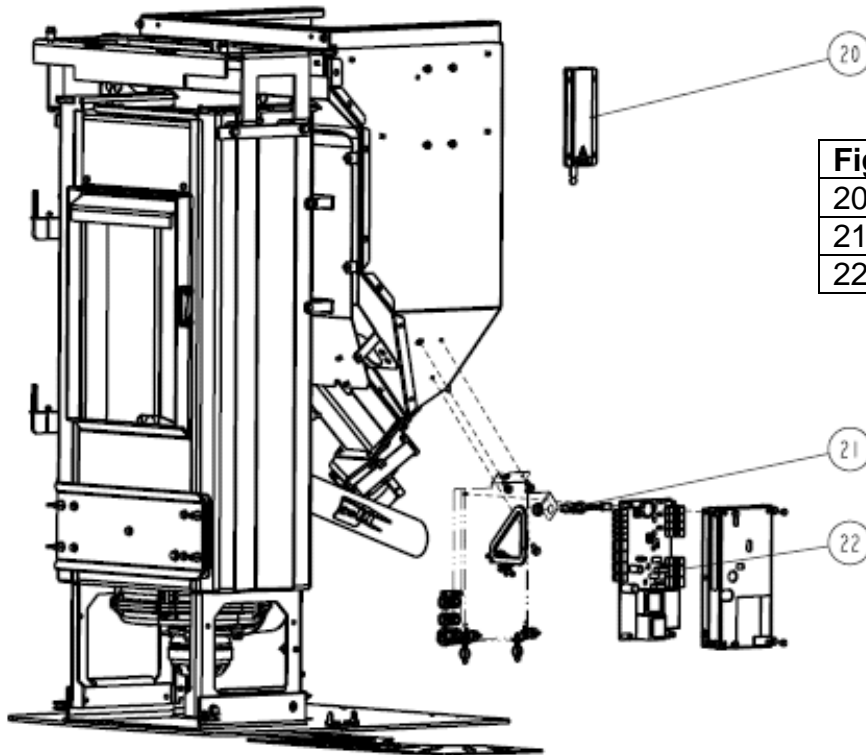

Fig. 4

Figure 4	
20	User board
21	Main fuse
22	Main board

PARTS ILLUSTRATION

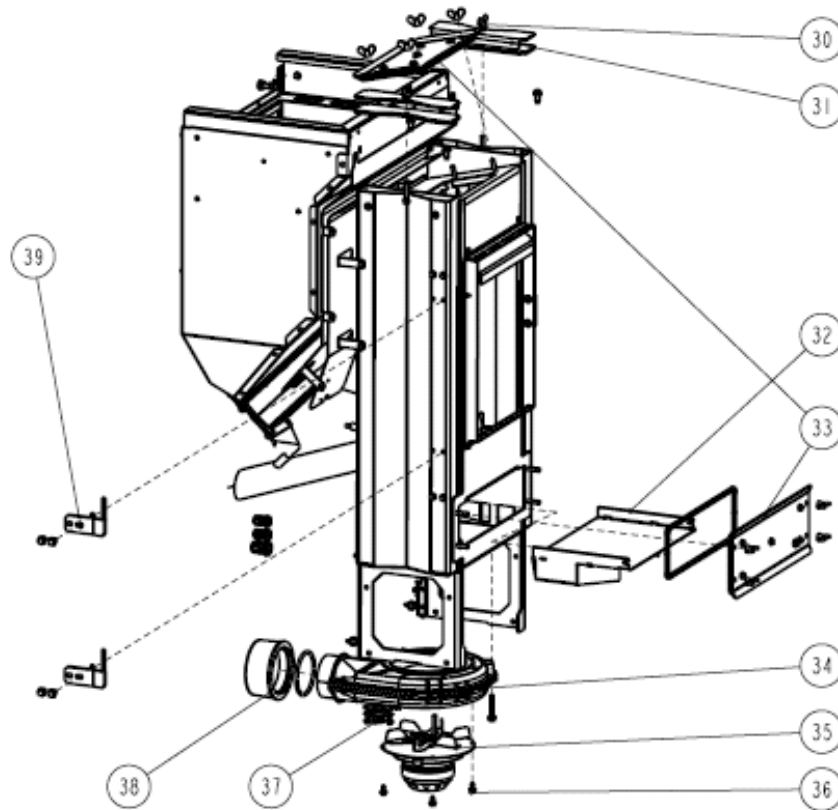

Fig. 5

Figure 5
30 Wing nut
31 Exhaust gas shaft cleaning lid
32 Intermediate bottom
33 Top / bottom cleaning lid
34 Combustion fan housing
35 Combustion fan
36 Hexagonal screws
37 Low-limit temperature switch
38 Flue adapter 3"
39 Combustion door hinge

PARTS ILLUSTRATION

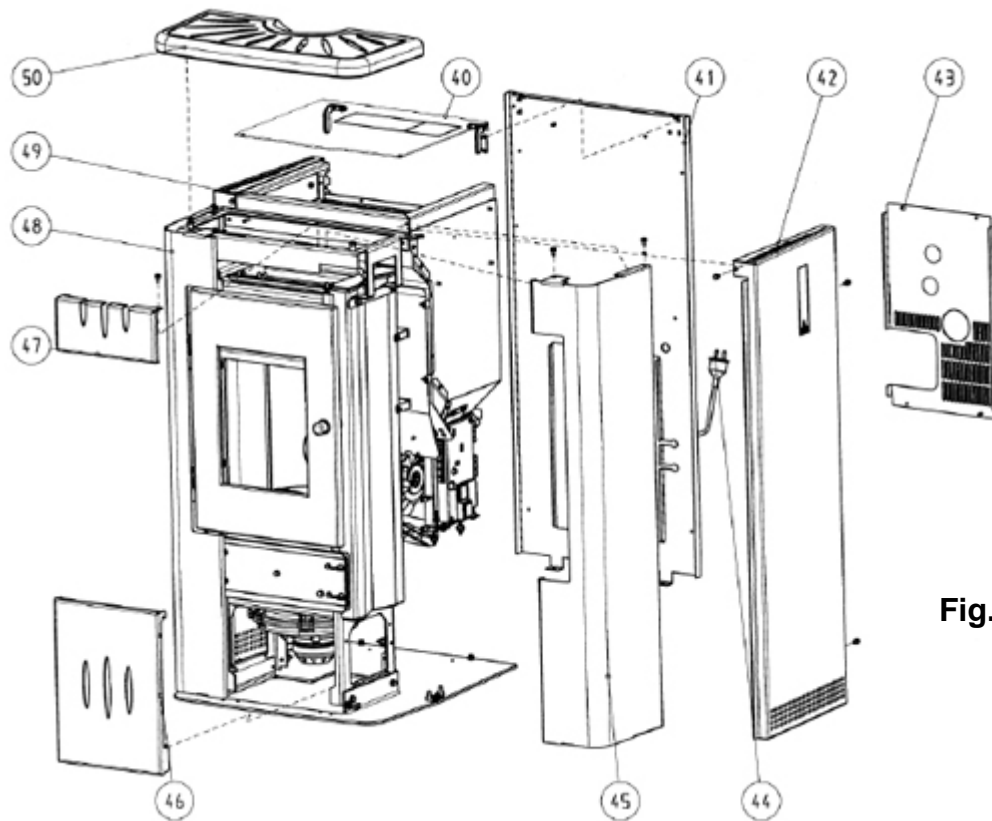

Fig. 6

Figure 6
40 Hopper lid
41 Rear wall
42 Side cladding rear right complete
43 Rear wall cover
44 Power cable with grounded plug
45 Corner post front right complete
46 Front cladding bottom
47 Front cladding top
48 Corner post front left complete
49 Side cladding rear left complete
50 Lid with insert

AUTOMATIC SAFETY FUNCTIONS

1. FOLLOWING A POWER FAILURE

In the case of a power failure, the stove resumes the same operating functions that were set before the power failure occurred.

ON-Mode (Manual mode):

If the stove was turned on in manual mode, the stove will turn itself back on when power resumes. The control display will read ST-21 (Start Phase) and then will display ON at the conclusion of the 21-minute startup cycle.

TM-Mode (Automatic mode):

If the stove was in the TM mode (controlled by your preset start and stop time schedule), the stove will resume the preset schedule when power resumes. The control display will read ST-21 (Start Phase) and then will display TM at the conclusion of the 21-minute startup cycle if the stove is within a scheduled heating period or if the power end heat setting is not set to off.

SB-Mode (Standby mode):

If the stove was off but set in the standby mode, the control switches back into SB-Mode approximately 2-seconds after the power resumes. In this setting, the stove will not turn itself back on.

NOTE: In the case of power failure, a small quantity of smoke can escape from the stove. This is normal in a power outage. If this occurs, open windows and doors to alleviate the smoke.

2. OVERHEATING

If the stove overheats, an excess temperature safety switch (Hi-Limit) will shut-off the pellet feed and force the stove to shut down.

ATTENTION: If overheating has occurred, maintenance/cleaning and inspection must be performed by an authorized service technician.

3. LOW TEMPERATURE SWITCH OFF

If the stove cools down below a minimum allowable temperature, the stove will go into automatic shut down mode. This may be caused by low pellet feed or an empty hopper.

4. AUGER MOTOR

When the hopper lid is open, the auger motor will stop feeding pellets. This safety is installed to protect you from potential injury should you stick your finger or any foreign object into the auger shaft.

ATTENTION: The auger will only operate when the hopper lid is closed.

INSTALLATION

This stove should be installed by an authorized service technician.

Before installing, contact your local building or fire officials about restrictions and installation inspection requirements in your area. Manufacturer and distributor have no control over the installation of the stove and assume no responsibility for any special, incidental or consequential damages caused by improper installation.

The following installation guidelines must be followed to ensure conformity with both the safety of this stove and with local building codes.

FLOOR PROTECTION

The stove must be installed on a non-combustible surface. A single-layer 3/8" non-combustible floor area, or equivalent is required.

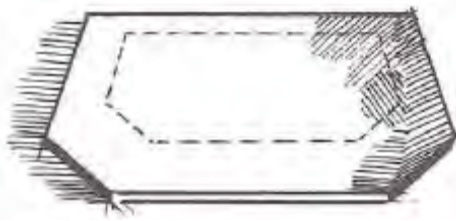

Design Guidelines for the Exhaust System

The stove must be connected to an approved 4" pellet vent chimney. See Installation Instructions for more information.

DO NOT INSTALL A FLUE DAMPER IN THE EXHAUST VENTING OF THIS STOVE!

DO NOT CONNECT THIS STOVE TO A CHIMNEY FLUE SERVING ANOTHER APPLIANCE!

The exit terminal must be located no less than 40 inches from any opening through which combustion products could enter the building (i.e. windows and doors), no less than 24 inches from an adjacent building, and no less than seven feet above grade, when located adjacent to public walkways. It must be arranged so that exiting flue gasses will not be a hazard to people, overheat combustible structures, or enter into any building.

DO NOT CONNECT TO ANY AIR DISTRIBUTION DUCT OR SYSTEM!

Keep brush, plants, and shrubs at least 36" away from the vent termination.

The total length of horizontal vent must not exceed 5 feet. The "PL" vent exhaust system must be installed and sealed with 3 screws per joint. The chimney manufacturer's installation procedures must be followed. In addition, pipe connections, joints, and all pipe seams within the home should be sealed with high-temperature silicone sealer, and (RTV) aluminum tape.

ELECTRICAL CONNECTION

The stove is supplied with a 7' to 8' power cord. This cord must be connected to a properly polarized, normal 110v, 60Hz grounded electrical outlet. The average power consumption is approximately 100 watts under normal operation. During the ignition process (duration of 12 minutes), power consumption is approximately 300 watts. The power cord must be run so that any contact with hot or sharp-edged external surfaces is avoided.

COMBUSTION AIR

The combustion process requires oxygen or air. As a rule, the combustion air is taken from the living area in the home. The air taken from the living area must be re-introduced. Tight fitting windows and doors means too little air flows into the house for proper combustion. This situation becomes problematic due to additional ventilation in the house such as kitchen or bathroom exhaust fans. An additional outside air source may be necessary for adequate air and optimum combustion.

VENT CLEARANCES

Install all vent at clearances specified by the vent manufacturer.

CANADIAN INSTALLATION

Where passage through a wall, or partition of combustible construction is desired, the install shall conform to CAN/CSA-B365.

Clearances may only be reduced by means of approved regulatory authority.

INSTALLATION

CLEARANCES TO COMBUSTIBLES

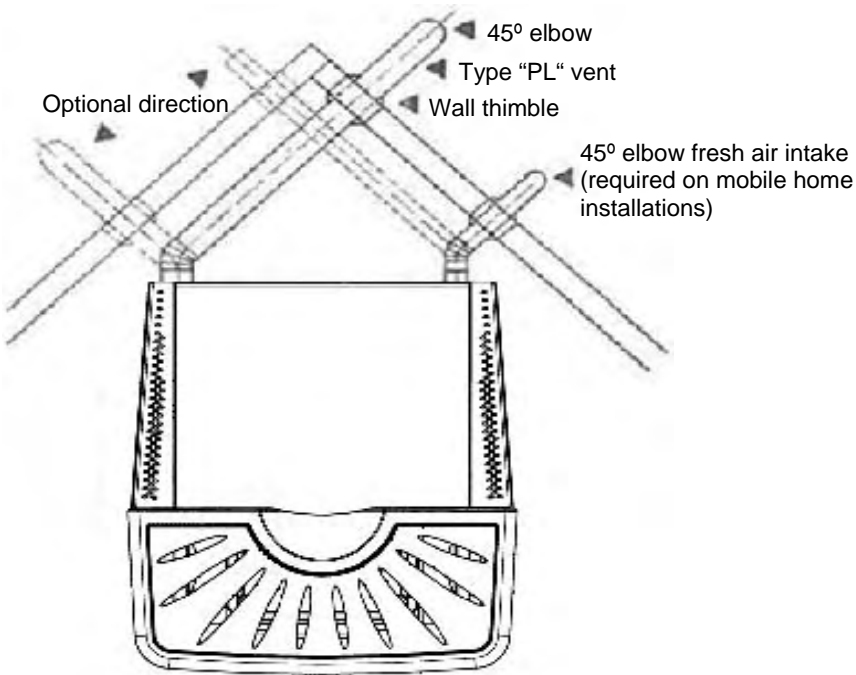
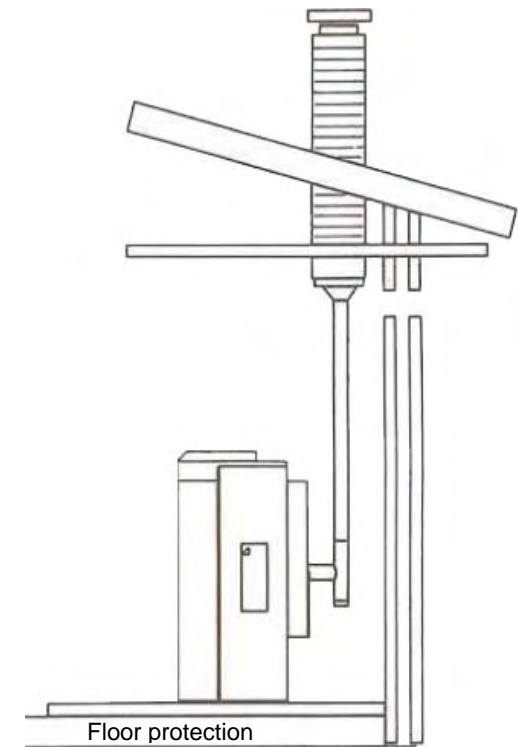
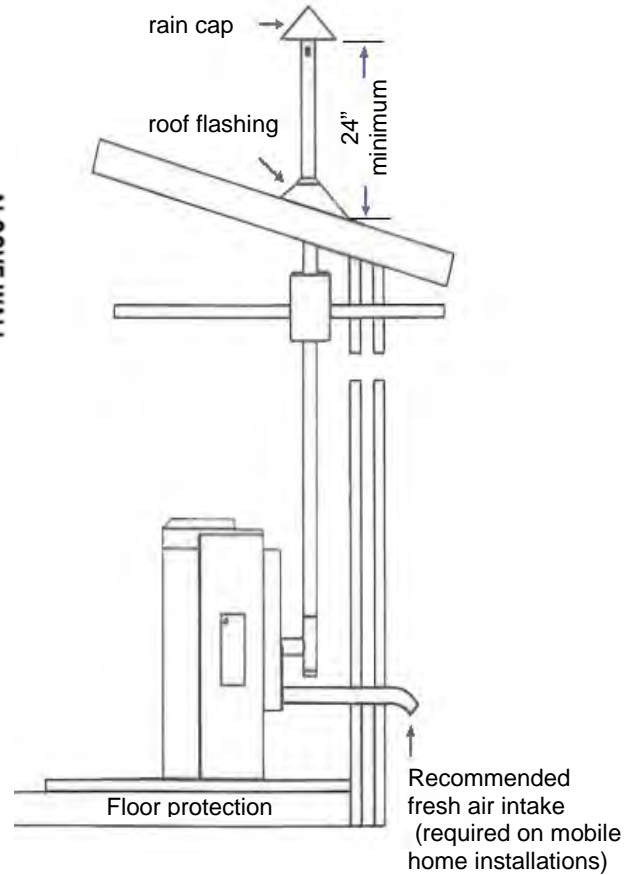
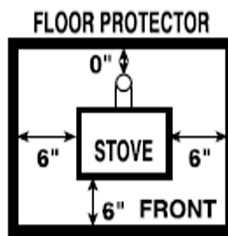
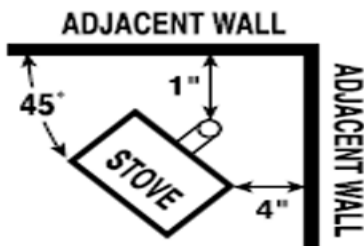
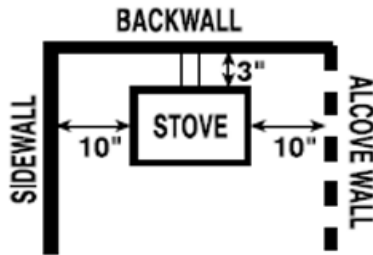
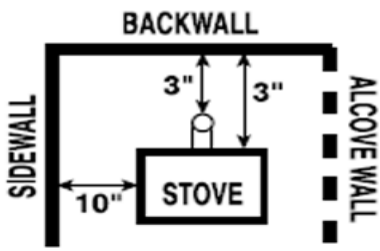

Additional Venting Instructions:

- 4-inch venting is required in all installations.
- Straight out horizontal venting is acceptable, however if a vertical termination is desired, minimum vertical rise (to termination point) must be no less than the total height of the stove.
- Each 90° angle or T-connector adds an effect of 5 additional feet of pipe length. Each 45° angle adds an effect of 3 additional feet of pipe length.
- The maximum length of any venting configuration should not exceed 30 feet total, including the effective lengths of any angles.

Optimum combustion and burn quality cannot be achieved if these guidelines are not followed. Failure to follow these guidelines could void your warranty.

MOBILE HOME INSTALLATION

In addition to standard installation instructions, the following requirements are mandatory for installation in a mobile home:

1. The unit must be permanently bolted to the floor.
2. The unit must have a permanent outside air source.
3. The unit must be permanently electrically grounded to the steel chassis of the home.
4. Use silicone to create an effective vapor barrier at the location where the chimney or other component penetrates to the exterior of the structure.

For use in mobile or manufactured homes, the stove must be installed in accordance with the Manufactured Home and Safety Standard (HUD), CFR32 80, Part 24.

Design guidelines for outside air connection

1. A connection to the outside is REQUIRED for mobile home installations.
2. Only metal pipe with a minimum two inch diameter is approved for use as an outside air connection (straight or flexible). PVC pipe or aluminum pipe is NOT approved and should never be used.
3. If the air inlet is connected to the outside, it must be terminated with a vertical 90 degree bend (down) or with a wind hood.

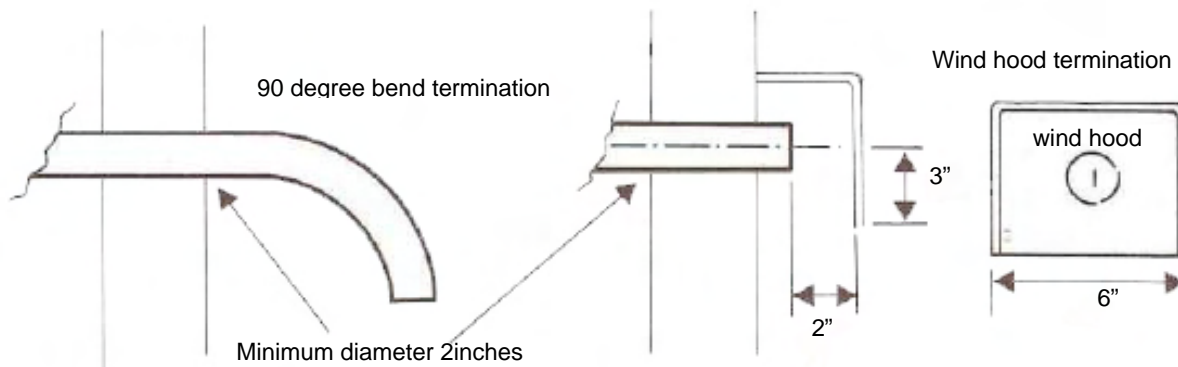

WARNING:
DO NOT INSTALL IN SLEEPING ROOMS.

COMBUSTION AIR MUST COME FROM THE OUTSIDE OF THE MOBILE HOME.

CAUTION:
THE STRUCTURAL INTEGRITY OF THE MANUFACTURED HOME FLOOR, WALL AND CEILING / ROOF MUST BE MAINTAINED.

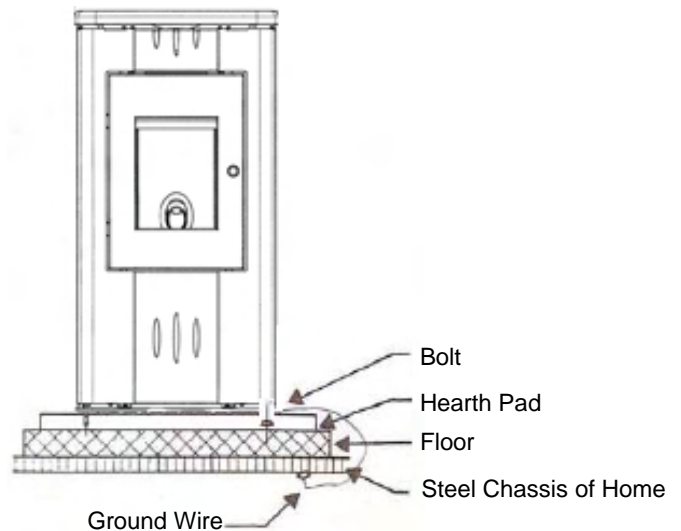

4. Blockage, excessive length, or bends in the air intake will starve the unit of combustion air.

A 90 degree bend is equivalent in restriction to approximately 30 inches of straight pipe

A NEW HEATING PHILOSOPHY

In today's world, anyone manufacturing and marketing heating appliances has more than just the responsibility of producing a quality, safe product. It is essential that wood heating appliances apply technology which is environmentally friendly and, at the same time, extremely efficient.

Rika is 100% committed to this obligation, and continues to do research and development in pellet stove combustion technology. This gives you, the consumer, assurance that you are buying the most advanced product in the marketplace.

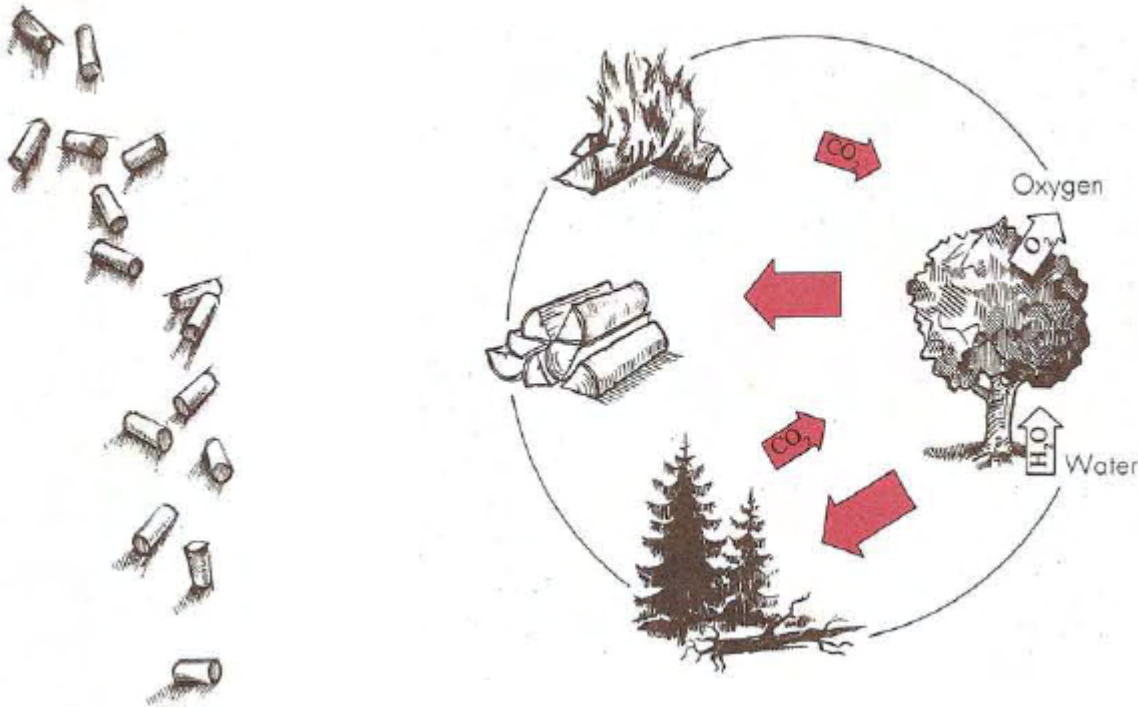

WHY HEAT WITH PELLETS?

Chemically speaking, burning wood is the same process as wood rotting by itself. Rotting wood, as well as burning wood, releases CO_2 that trees need to grow and, therefore, burning wood has no impact on the CO_2 cycle. Heating with pellets means that the burning process is very carefully controlled, and wood is added to the combustion process only in precise quantities. This results in the optimized and environmentally friendly incineration of wood.

In the past, waste wood products were simply discarded into local landfills to rot. Heating with pellets is an economical and a distinctly advantageous alternative to dumping. It is a natural and intelligent method of recycling. Heating with your Austroflamm pellet stove is designed to be easy and user-friendly. Because of its exceptionally large hopper, low pellet consumption, and very simple control panel, your Austroflamm pellet stove is, indeed, easy and convenient to operate.

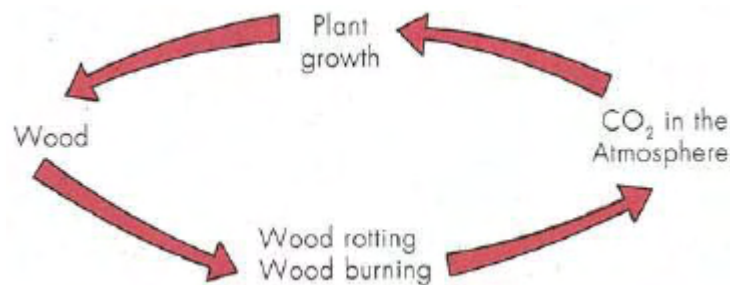

WHAT ARE PELLETS

The RIKA Visio is a pellet stove designed to burn wood pellets. Pellets are made of waste material from saw mills, woodworking operations, as well as dead wood from forestry operations. The wood pellet industry is organized through the association of the Pellet Fuel Institute, and it is recommended that only wood pellets, manufactured to the standard set by the P.F.I. be used with this pellet stove. All pellets made to these standards are labeled with an official P.F.I. registration number on the bag. This guarantees the consumer that the fuel is certified as to moisture and ash content.

The P.F.I. allows two grades: Standard and Premium quality pellets. The important difference in these pellet grades is their ash content.

Premium quality: 1% or less ash content

Standard quality: Up to 3% ash content

A higher ash content in the fuel means more combustion residue which means shorter cleaning intervals. (see the Routine Maintenance & Cleaning section).

ASH

It is highly recommended that you use the lowest ash-content fuel available. Using fuel with 3% ash content may require that the stove be cleaned as often as every one to two days. Fuel with 1% ash content may only require cleaning once every one to two weeks.

The ash produced while your stove is operating, since it is a completely natural product, makes an excellent fertilizer for all of your garden plants. However, it should be aged and mixed with water before use.

Please note that use of improper fuels will void your warranty and may cause damage or seriously impact the performance of your stove.

The current P.F.I. standards for residential pellet fuels are as follows:

	Standard Quality	Premium Quality
Heating Value	8,200 BTU/lb. (minimum)	8,200 BTU/lb. (minimum)
Bulk Density	40lb/ft ₃ (minimum)	40lb/ft ₃ (minimum)
Moisture Content	8% (maximum)	8% (maximum)
Ash Content	3% (maximum)	1% (maximum)
Size	¼" to 5/16" diameter 1-1/2" long (maximum)	¼" to 5/16" diameter 1-1/2" long (maximum)
Fines	0.5% maximum through a 1/8" screen	0.5% maximum through a 1/8" screen

Caution: Burning dirty or wet pellets, or pellets containing salt, can contaminate the environment, adversely affect the function of your pellet stove, and will void your warranty.

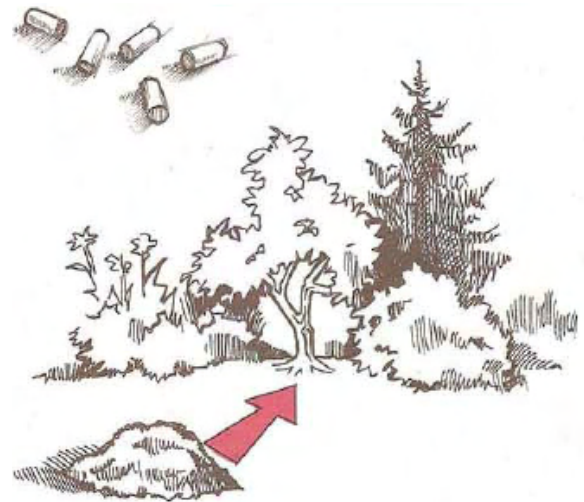

Caution: Embers may be embedded and hidden in the ash. Store in metal containers only!

STORING PELLETS

To guarantee that your pellets will burn without any problems, they should be stored in a dry and clean environment.

CAUTION: DO NOT PLACE SUCH FUEL WITHIN THE INSTALLATION CLEARANCES OR WITHIN THE SPACE REQUIRED FOR FILLING THE HOPPER OR REMOVING THE ASH.

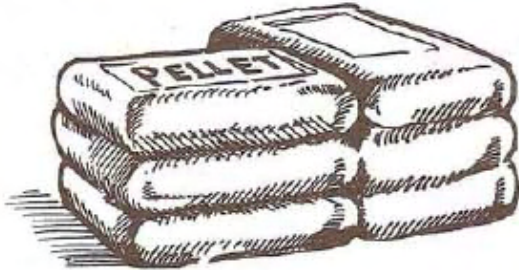

If you have any further questions regarding fuel for use in your Austroflamm pellet stove, please contact your dealer or the P.F.I.

Pellet Fuel Institute
1901 North Moore Street #600
Arlington, VA 22209
(703) 522-6778

CLINKERING

“Clinkering” is the process that takes place in the burn pot. A clinker is a solid substance that accumulates due to heat and silica working together and forming deposits during combustion. Silica is actually sand and is present in all pellet fuels along with a variety of other impurities. When clinkering takes place, these hard substances tend to accumulate

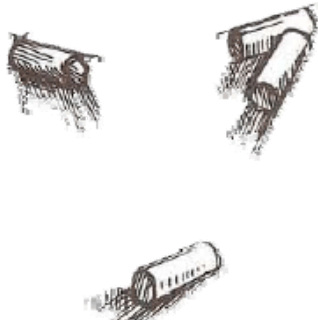

at the bottom of the burn pot. This adversely affects the performance of the stove as it cuts off the air supply to the combustion process. The burn pot should be checked periodically for clinkers, and all hard substances should be removed to allow proper air flow through the bottom of the burn pot. It should be noted that even P.F.I. approved pellet fuels will cause some clinkering to occur.

For more information about how often to clean your stove, see the Routine Maintenance & Cleaning section of this manual.

There is no warranty for damage or poor performance caused by the use of inferior or improper grades of pellet fuels. The manufacturer is not responsible for the performance of the stove due to the use of non P.F.I. approved pellet fuels.

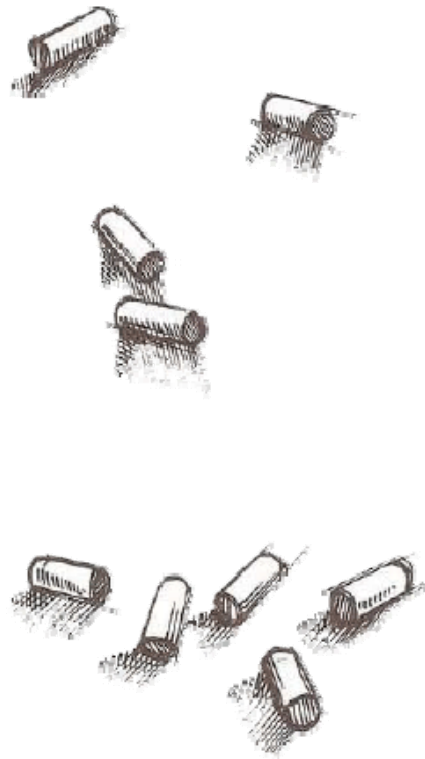

BASIC OPERATION

DO NOT start your stove until the venting installation is complete

NOTE: Your pellet stove is exclusively for burning pellets made from wood of a controlled quality. Non-pelletized solid fuels (straw, corn, chopped matter, etc.) should not be used. Failure to adhere to these guidelines could void your warranty.

NOTE: When operated correctly, your pellet stove will not overheat. Improper operation can, however, shorten the life expectancy of the stove and its components.

ATTENTION: Your stove's automatic ignition system will not work properly if either the hopper lid or combustion door are open.

CONTROL UNIT PROGRAMMING AND FUNCTION

Your pellet stove is equipped with a modern programmable control board and control software. The owner can set all equipment functions via the control keypad which is found on the right hand side of the unit. The control board and software should only be altered by trained specialists. Improper or unauthorized changes to your stove, unless outlined in your owner's manual or this operating guide, will void your warranty.

Possible Operating Modes

Pressing enter on the control panel enables the user to change between each of the three different operating modes.

- Manual Mode - press the power button to turn the unit on and off.
- Automatic or Timed Mode (TM) - runs according to the schedule that you determine.
- Standby Mode (SB) - waiting for you to change to one of the other two modes by pressing the "Enter" button on the key-pad. No function, other than programming, occurs in this mode. **NOTE:** It is NOT necessary to be in SB mode in order to program your stove.

Your RIKA pellet stove is equipped with an electronic ignition start-up system. Starter fluids or gels are not necessary and should never be used. Simply push the power button and the unit will ignite within a 10-minute period of time. Total start-up cycle time is 21 minutes.

Control Keypad

All settings and functions can be regulated via this unit.

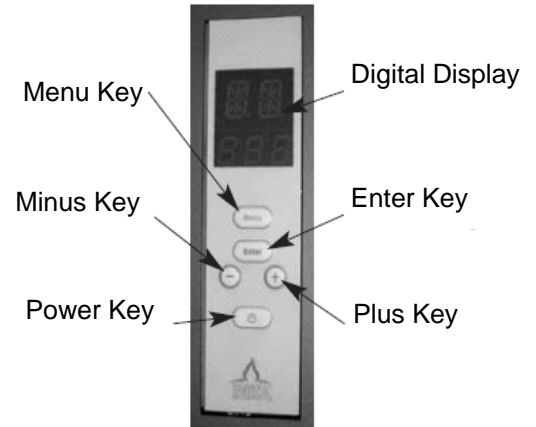

DISPLAY BOX

Displays the operating modes in illuminated letters and numbers.

MENU

Used for navigation in and to the different menu and sub-menu levels.

ENTER

Used for navigation through the main menus (SB, ON, TM) and for confirming user entries.

MINUS & PLUS

Used for lowering or increasing heat output levels, and for changing program values.

POWER

Used for turning the unit on and off.

A handle is provided for opening and closing the door. There is knob on the upper right back side of your stove for storing the handle when not in use.



STARTING / PROGRAMMING THE CONTROL

When the hopper is filled for the first time or if it is allowed to run empty, it can take up to two full start-up cycles for pellets to feed sufficiently into the burn pot.

Under these circumstances the stove may shut-down and display ERR or ERR/CL at the end of the start-up cycle. Re-start the stove and the feed rate should return to normal.

Initial Startup

Verify that there are pellets in the hopper, that the burn pot is empty and seated properly, and that the unit is plugged into a 110v grounded outlet.

SB Press the "ON/OFF" button. The display should read "SB". If the display does not read "SB", press enter until it does.

Depending upon the current status of the stove, it may turn on at this point.

You may now program your unit for your individual needs. You can set up to two start-up / shut-down cycles for each day of the week.

NOTE: When in programming mode, if no change is needed on a particular setting simply press enter to advance to the next setting.

MO From the "SB" mode, press the "MENU" button. The display should read "MO" for Monday.

S1 6 Press the "ENTER" button. The display should read "S1" for the first heating period on Monday, the number represents the start time. Change the time by pressing the "+" or "-" keys. Confirm by pressing "ENTER".

NOTE: Start and end times are in military format (displays as 0 for midnight through 23 for 11pm).

E1 8 The display should now read "E1" for the ending time of the first heating period on Monday. Change the time by pressing the "+" or "-" keys. Confirm by pressing "ENTER".

S2 16 The display should now read "S2" for the second heating period on Monday. Change the time by pressing the "+" or "-" keys. Confirm by pressing "ENTER".

E2 20 The display should now read "E2" for the end time of the second heating period on Monday. Change the time by pressing the "+" or "-" keys. Confirm by pressing "ENTER".

MO The display should now read "MO".

TU Press "MENU". The display should now read "TU" for Tuesday.

Repeat the prior steps to set the start and end times for each day of the week. "WE" Wednesday, "TH" Thursday, "FR" Friday, "SA" Saturday, "SU" Sunday.

PS 75 After entering the "E2" value for Sunday, press "MENU" and the display should read "PS".

"PS" represents the percentage of heat output that you want your stove to operate at when it is scheduled to be on (0% to 100%). 0% maintains flame with minimal heat, 100% produces maximum heat output.

Change the output setting by pressing the "+" or "-" keys. Confirm by pressing "ENTER".

PE OFF The display should now read "PE" for Power End. This represents the output level **between** the pre-programmed heating cycles that you just defined. In other words, what power level should the stove operate at between the end time of one cycle, and the start time of the next cycle.

Use the "+" or "-" keys to choose any level between 0% and 100%, or you can choose for your unit to turn off between cycles. Confirm your setting by pressing "ENTER".

PROGRAMMING THE CONTROL

PE
5 This corresponding figure shows that the unit will run at 5% output between cycles.

CL
60 After pressing enter on the “PE” output setting, the display should read “CL” with a number that represents how often in minutes the cleaning cycle should activate. Change by pressing the “+” or “-” keys. Press “ENTER” to confirm.

The factory setting is every 60 minutes but the schedule can be set to run anywhere from 0, which is never, or any frequency between every 5 and 300 minutes.

The frequency of how often the cleaning cycle should run can vary depending upon pellet quality, heat output settings, availability of outside air, and the natural ventilation of your home.

VU
1.29 The display should now read “VU” after pressing enter on the “CL” cleaning cycle setting; the number represents the current version of the control software on your stove.

The software version of your stove may vary depending upon purchase date.

H
13 Press “ENTER” again and the display should read “H” for the current hour in military format. Set the current hour by pressing the “+” or “-” keys. Press “ENTER” to confirm.

M
47 The display should now read “M” for the current time in minutes. Change by pressing the “+” or “-” keys. Press “ENTER” to confirm.

D
3 The display should now read “D” for the current day. 1=Monday, 2=Tuesday, etc. Change by pressing the “+” or “-” keys. Press “ENTER” to confirm.

Press “MENU” to exit programming mode.

SB Your stove should now be in Stand-by mode and the display should read “SB”.

At the completion of the above steps, your stove will be programmed according to your personal preferences.

You can change your programmed settings at any time by repeating the steps outlined in this manual.

NOTE: Although you may have programmed an operating schedule for your stove, that schedule will not be activated until your stove is put into the Timed or Automatic Mode (TM) as described above.

NOTE: It is not mandatory that you program a schedule for your stove. The option exists for your convenience.

If you choose not to establish an operating schedule, your stove can be operated manually. In manual mode you turn it on/off by pressing the power button, and increase/decrease heat output by pressing the “+” or “-” keys on the control keypad.

If you intend to operate your stove manually, set it to either the Manual or Stand-by (SB) mode.

During start-up, the stove will read “ST” on the first display line, and “21” on the second display line. “ST” stands for start-up and “21” is the remaining start-up time in minutes (the time display will decrease as the start-up progresses).

During the start-up cycle, only the auger and combustion fan operate with the combustion gradually increasing in speed. The convection fan will turn on at the end of the start-up cycle.

NOTE: As long as the stove is running, whether in the start-up mode, cleaning cycle, or in normal operation, you can increase or decrease the heat output level at any time by pressing the “+” or “-” keys.

If the stove needs to be turned off at any time, push the ON/OFF button and the stove will immediately begin the shut-down process. Complete shut-down takes a total of eight minutes.

NOTE: Page 31 of this manual contains an area where you can record your personal program settings.

MAINTENANCE AND CLEANING

SEE PAGE 26 FOR A CLEANING FREQUENCY SCHEDULE

Turn your stove off, allow it to cool, and disconnect power before performing any cleaning or maintenance.

Regular maintenance is important to the efficient operation of your stove. Cleaning and maintenance frequencies depend upon the quality and quantity of the pellets that you use. Using poor quality pellets will increase the need for more frequent cleaning.

Use only premium quality pellets containing 1% or less ash, and 8% or less moisture content as defined by the Pellet Fuel Institute. Only use fuel that has a P.F.I. registration number printed on the bag. Using any other type of pellets will void your warranty.

You will attain the best cleaning results by using a certified ash vacuum. An ash vacuum can be purchased from your stove dealer. **Do not use a non-certified ash vacuum for cleaning your stove.** Failure to follow this warning can lead to a fire.

CLEANING THE BURN POT

Cleaning frequencies can range from every one to 10 days, depending upon pellet quality, chimney configuration, and the availability of outside air. Clean as the flame pattern deteriorates. Do not allow the air intake holes in the burn pot to get clogged with ash and clinker.

The burn pot is easy to clean by removing it from the stove, scraping the clinker loose, and vacuuming with your ash vacuum. Also vacuum the area underneath the burn pot (picture 3).

CLEANING EXHAUST AIR PASSAGES

The exhaust air passages are located on both sides of the burn pot (Picture 3). Use your ash vacuum to clean this area. Clean the exhaust air passages every time you clean the burn pot.



Picture 3

CLEANING THE DOOR

Clean the door glass with a damp cloth. Use a soot or paint brush to clean the metal and gasket areas of the door. Clean the door every time you clean the burn pot.

BAFFLE AND HEAT EXCHANGER

Remove the colored top panel. Remove all six of the wing nuts and washers on the top of the stove (see picture 4) then lift the cleaning and combustion chamber lids off. Be careful not to drop the wing nuts or washers down into the heating gas flues or combustion chambers.

MAINTENANCE AND CLEANING



Picture 4

Vacuum the exposed baffle and heat exchanger areas (see pictures 5 and 6).

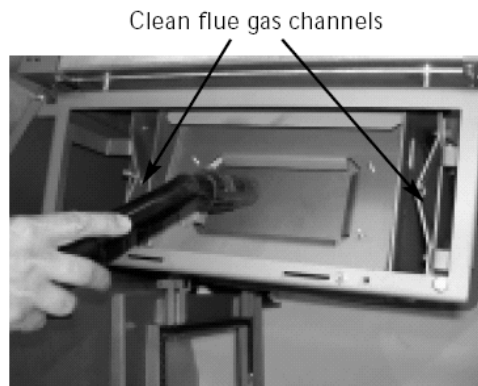

Picture 5

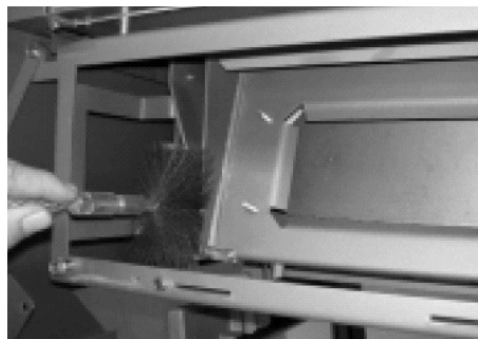

Picture 6

CLEANING THE EXHAUST AIR MANIFOLD

The exhaust air manifold is located in the bottom area of the combustion chamber behind the bottom colored panel (Pictures 7 through 10).

After removing the front side panels, open the door and lift out the bottom colored panel. Remove the bottom inspection opening by removing the four wing nuts.

MAINTENANCE AND CLEANING

Using your ash vacuum, clean all of the areas (as shown in pictures 7 through 10)



Picture 7



Picture 8



Picture 9



Picture 10

When finished cleaning these areas, replace the covers, re-fasten all washers and wing nuts, and replace the bottom colored panel. **NOTE:** Most ash accumulation in this area can be accessed using your ash vacuum, and can be cleaned during a routine burn pot cleaning.

If a more in-depth cleaning is to be performed (see the following cleaning sections), do not re-attach the side panels at this time.

CLEANING THE PELLET HOPPER

Allow the hopper to run empty prior to cleaning. This will allow you to remove any pellet residue (dust, chips etc.) from the empty hopper using your ash vacuum.

INSPECTING THE DOOR SEAL

Visually inspect for a missing, damaged or loose fitting door seal. These conditions can cause your stove to burn improperly. This will lead to increased glazing of the glass, increased clinking, increased frequency of cleaning, and can cause flue gasses to escape into the room.

Only a qualified service technician should perform the following cleaning procedures

CLEANING THE EXHAUST AIR FAN HOUSING

Remove the right and left side rear panels to gain access to the combustion fan. Remove the four hexagonal bolts and carefully remove the combustion fan motor (there is a gasket that seals the fan to the housing; be careful not to damage the gasket as you remove the fan). Using your ash vacuum, clean out any debris or ash from the fan and the flue gas path. When finished cleaning the fan and flue gas path, re-attach the fan and ensure that all seals are tight. Note: All of the motors have sealed ball bearings. No lubrication is required.

MAINTENANCE AND CLEANING

Check the condition of the seal around the door to ensure that it is not damaged or becoming detached. If the seal becomes damaged or detached, it must be replaced by a qualified technician.

CLEANING THE FLUE PIPE / CHIMNEY CONNECTION

Remove the clamp that connects the flue to the flue adapter housing on the back of the combustion chamber. Be careful not to remove or tear the protective foil-lined wrap that surrounds the portion of the chimney that sits inside of the stove body.

The foil wrap helps reduce temperatures inside the stove body while in operation. Damage to, or removal of the foil wrap could lead to an overheat condition that could damage your stove or cause a fire. If the wrap becomes lost or damaged, it must be replaced by a qualified technician.

Once the flue has been detached from the flue housing, use your ash vacuum to remove any ash or debris that may have accumulated in the flu outlet.



Picture 11

Upon completion of cleaning, re-attach the flue, and re-attach all panels.

CLEANING FREQUENCY SCHEDULE

Area	Frequency	Page
Burn Pot	every one to 10 days depending upon fuel quality, vent configuration, and conditions in the home	23
Exhaust Air Passages	same as burn pot	23
Combustion Door	same as burn pot	23
Heating Gas Flues	at least four times per heating or after every 500 lbs of fuel consumed	24
Exhaust Air Manifold	same as heating gas flues	25
Inspecting the Door Seal	same as burn pot	25
Pellet Hopper	as needed or two times per heating season	25

Only a qualified service technician should perform the following cleaning procedures

Exhaust Air Fan Housing	a minimum of one time per heating season or after every 1-ton of fuel consumed	25
Flue Pipe/Chimney Connection	same as exhaust air fan housing	26

TROUBLESHOOTING

PROBLEM

The fire is burning with a weak, orange flame. Pellets are collecting in the burn pot, the window is glazing.

CAUSE:

Inadequate combustion air.

POSSIBLE SOLUTIONS:

- Make sure that the unit has been cleaned. See the Cleaning and Maintenance section of this manual.
- Verify that the burn pot is correctly seated in place.
- Remove any ash or clinker that may be blocking the air inlet openings in the burn pot.
- If possible, change to a better pellet quality.
- Verify that the flue pipe is not blocked with ash. See the Cleaning and Maintenance section of this manual.
- Verify that the air inlet is clean and free of debris. Dust and animal hair can collect on the air sensor and cause the sensor to send false readings to the control system.
- Check door seal.
- Verify that sufficient air flows into the home. This can be done by opening a window or door. If the flame quality improves, an outside air kit may be necessary.

PROBLEM

The fire goes out and the stove switches itself off automatically.

CAUSE(S):

- Pellet hopper is empty.
- Thermal switch (upper temperature safety limit) was triggered.
- The door seal is not tight, is damaged, or the door is not closed properly.
- Poor pellet quality.
- Pellet feed rate too low.
- Thermal switch (lower temperature safety limit) was triggered.
- Cleaning openings are not close properly or components seals are not sealed properly.

POSSIBLE SOLUTIONS:

- Fill the hopper with pellets.
- Perform routine maintenance and cleaning.
- Change the brand of pellets used and only use quality pellets.
- Increase the heat output level.

PROBLEM

Pellets are not feeding

CAUSE(S):

- The hopper is empty
- The auger motor or control board is faulty.
- The auger is blocked (foreign objects, large pieces of wood, etc.).

POSSIBLE SOLUTIONS:

- Fill the hopper with pellets.
- Have the dealer check the fault and replace parts if necessary.
- Clean the hopper and auger shaft of foreign debris.

TROUBLESHOOTING

PROBLEM

The unit runs for 21 minutes during start-up, then automatically switches off.

CAUSE(S):

- Exhaust gas has not reached the required temperature.
- Lower temperature limit value switch possibly needs to be replaced.
- The connection to either the lower or upper limit temperature switches is loose or broken.
- Control board is faulty.

POSSIBLE SOLUTIONS:

- Re-start the stove.
- Have a qualified service technician check the control board and low limit switch, check for loose or incorrect wiring, and replace the low temperature switch and check control.
- Inspect the wiring for proper termination on each component (see block diagram on page 7). Check that there is a good connection between the lines and terminal ends on both the component and control board ends of each wiring loop, and that all components are plugged into the correct location on the motherboard.

CONTROL FLOW CHART

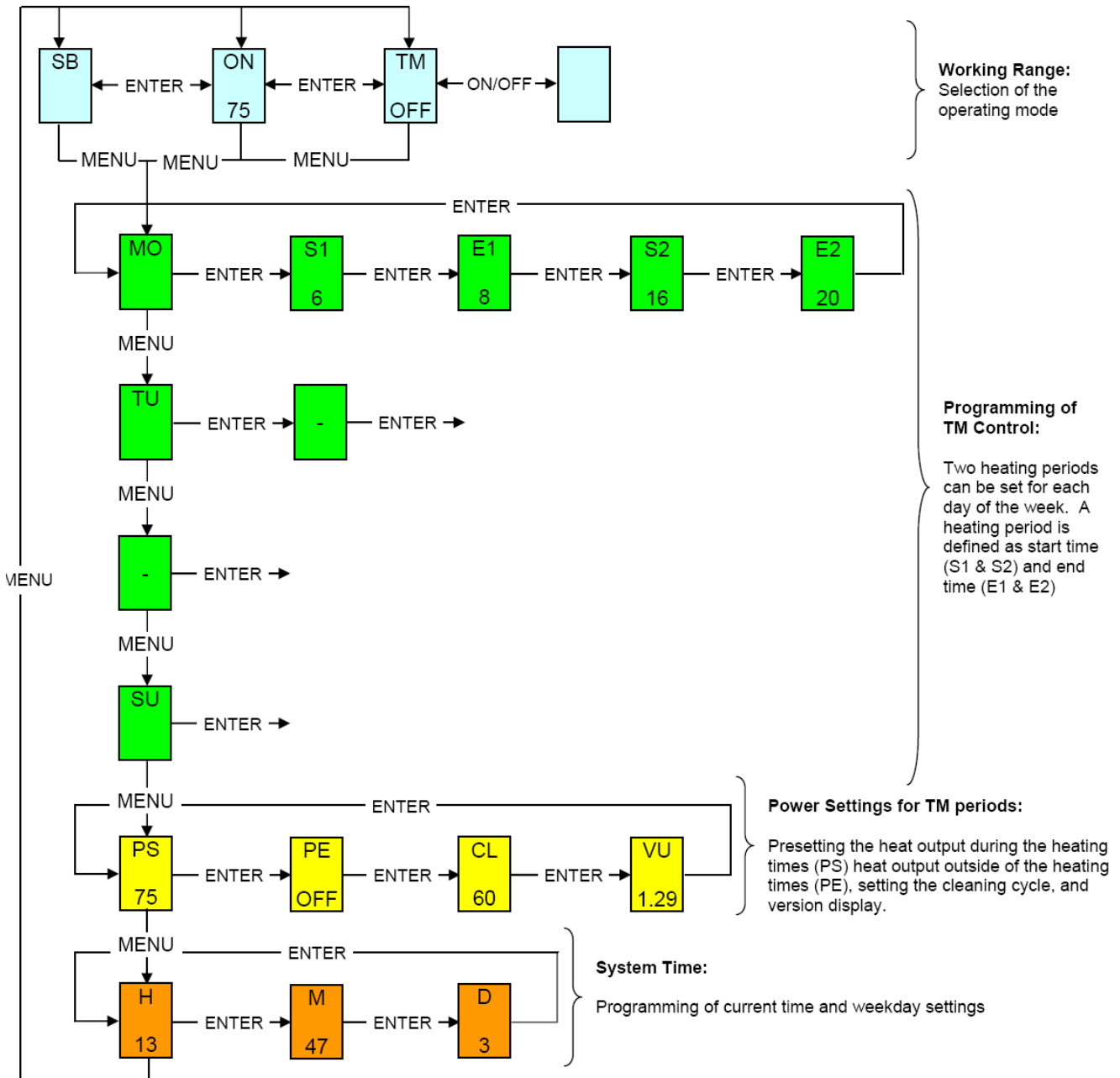

KEYWORD / ABBREVIATIONS LIST

Key word / Abbreviation	Name	Description
SB	Standby-Mode	Standby mode (fire switched off, but active for triggering via the control)
ON	On-Mode	Manual operation
TM	Time-Mode	Automatic Operation
MO, TU, WE, TH, FR, SA, SU	Weekdays	Monday to Sunday
S1, S2 E1, E2	Start 1, Start 2 End 1, End 2	Heating start times, heating end times for automatic TM mode
PS	Power-Start	Output value from the beginning of heating time in TM-Mode
PE	Power-End	Output value from the end of heating in TM-Mode
CL	Clean	Cleaning mode
VU	Version	Pellet control software version (varies depending upon purchase date)
H, M, D	Hour, Minute, Day	Hour, minute, day memory for internal clock (in military format)
ST	Start	Pre-heating / startup program run
EX	Exit	Exit program run
MENU	Menu Button	Navigation in and to the different sub-menu levels.
ENTER	Enter Button	Navigation in the main menus (SB, ON, TM) and confirming user entry
+/-	Plus & Minus Buttons	Increases and decreases user values
ON/OFF	ON / OFF Button	Turns the system on and off

WARRANTY

There is expressly no warranty on the following components:

- Glass
- Paint
- Metal Plating
- Gasket Material
- Burn Pots
- Ceramics
- Natural Stone

WARRANTY LIMITATIONS:

MANUFACTURER, DISTRIBUTOR AND SUPPLIER MAKE NO OTHER WARRANTIES, EXPRESS OR IMPLIED, INCLUDING ANY WARRANTY OF MERCHANTABILITY OR WARRANTY OF FITNESS FOR A PARTICULAR PURPOSE.

LIMITATION OF LIABILITY:

MANUFACTURER, DISTRIBUTOR AND SUPPLIER SHALL NOT BE LIABLE FOR ANY INCIDENTAL OR CONSEQUENTIAL DAMAGES TO PROPERTY OR PERSONS ARISING FROM OR RELATED TO USE OF THIS PRODUCT. USER'S SOLE AND EXCLUSIVE REMEDY FOR ANY NONCONFORMITY IN THE PRODUCT OR ANY CLAIM RELATED TO THE USE OF THE PRODUCT SHALL BE, AT MANUFACTURER'S OPTION, REPAIR OR REPLACEMENT OF THE PRODUCT, OR RETURN OF THE PRODUCT FOR THE PURCHASE PRICE PAID FOR THE PRODUCT.

The manufacturer provides a five year limited warranty on all steel parts (**except the burn pot**), and a **two year** limited warranty on all electrical components. These warranties commence on the date of the original purchase.

An optional five year extended warranty on all electrical components is available.

This warranty covers defects in materials and workmanship in covered components, provided the product has been installed and operated strictly in accordance with the Manufacturer's printed instructions. This warranty does not cover damage or breakage caused by improper handling, misuse, or unauthorized modification.

Without limiting the foregoing, the use of fuel other than wood pellets, or improper installation voids all warranties.

**AUSTROFLAMM/HPG
8111 NE Columbia Blvd.
Portland, OR 97218**

ALL WARRANTY CLAIMS MUST INCLUDE:

1. Name, address, and telephone number of the purchaser.
2. Name, address, and telephone number of the seller, date and proof of purchase.
3. Name, address, and telephone number of installer, and date of installation.
4. Serial number of the stove.
5. Nature of defect, malfunction, or complaint.

Arrangements will be made for inspection. If the inspection indicates that the failure was due to defective material or workmanship in covered components and that the other terms and conditions of this warranty have been complied with, the Manufacturer's sole duty and liability under this warranty shall be limited to the Manufacturer's replacement or repair, at the Manufacturer's option, of the defective unit or part. The purchaser assumes all costs of shipping to and from the Manufacturer or his agent and shall be responsible for all losses incurred during shipment. Removal and reinstallation costs are not covered under this warranty.

Neither the Manufacturer nor the supplier to the purchaser accept responsibility, legal or otherwise, for incidental or consequential damage to property or persons resulting from the use of this product. Any warranty implied by law, including, but not limited to, implied warranties of merchantability or fitness, shall be limited to one year from the date of the original purchase. Whether a claim is made against the Manufacturer based on a breach of this warranty or any other type of warranty, expressed or implied by law, the Manufacturer shall in no event be liable for any special, indirect, consequential, or other damages of any nature whatsoever in excess of the original purchase price of this product. All warranties by the Manufacturer are set forth herein, and no claim shall be made against the Manufacturer based on any oral warranty or representation.

Some states do not allow the exclusion or limitation of consequential damages or limitations of implied warranties, so the limitations or exclusions set forth in this warranty may not apply to you.

WARNING

Changes to the design characteristics or operating parts are not authorized by the Manufacturer and will void any and all warranties. Such changes may create hazardous conditions which can endanger the user and/or his property.

This warranty gives you specific legal rights, and you may have other rights which vary from state to state.



8111 NE Columbia Blvd.
Portland, OR 97218



NO POSTAGE
NECESSARY
IF MAILED
IN THE
UNITED STATES



BUSINESS REPLY MAIL
FIRST-CLASS MAIL PERMIT NO 911 PORTLAND OR
POSTAGE WILL BE PAID BY ADDRESSEE

RIKA
8111 NE Columbia Blvd.
Portland, OR. 97218-9901



This warranty registration guarantees your coverage.

To register your new RIKA stove, completely fill out the card below:
Fax it: 1-800-777-7069 *or*
Mail it: Postage is already paid.

WARRANTY APPLIES ONLY TO STOVES PURCHASED FROM LUCKY DISTRIBUTING, INC. OR ONE OF ITS AUTHORIZED DEALERS.

Warranty Proof: Your registration serves as proof of purchase for your warranty coverage. **Please make sure the card is completed in order to guarantee coverage.**



RIKA Customer Service: 1-800-777-5594 FAX: 1-800-777-7069

MR. MS. MRS.

FIRST NAME _____ LAST NAME _____

COMPANY NAME _____

ADDRESS _____

CITY _____ STATE _____ ZIP CODE _____

PHONE _____ E MAIL _____

DEALER NAME _____

DEALER PHONE _____ FAX _____

DEALER CITY _____ STATE _____ ZIP CODE _____

DATE OF PURCHASE _____ MODEL _____

Serial Number Information (required)

Pellet Stove Serial # _____

Pellet Stove Serial # _____ Pellet Stove Serial # _____

Wood Stove Serial # _____ Wood Stove Serial # _____

Wood Stove Serial # _____ Wood Stove Serial # _____

Friend Received information from DLRS

Dealer Recommendation

Magazine (please specify) _____

Other (please specify) _____



Warranty Registration

