



MANUAL

INTEGRA II

Freestanding



TABLE OF CONTENTS

INSTALLATION AND ASSEMBLY

RIKA: An Overview	3
Safety Precautions	4
Labels	6
Main Control Board/Specifications	7
Parts Illustration	8
Automatic Safety Functions	12
Installation Instructions	13
Mobile Home Installation	16
A New Heating Philosophy	17

PELLETS / GENERAL

What Are Pellets?	18
Storing Pellets	19

OPERATING INSTRUCTIONS / FEATURES

Basic Operation	20
Starting / Programming Control	21

MAINTENANCE AND CLEANING

Maintenance and Cleaning	24
Trouble Shooting	27

MISCELLANEOUS

Control Flowchart	29
Key Word Abbreviations	30
User Notes	31

WARRANTY

Warranty	32
Warranty Registration Card	33

SAFETY NOTICE

IF THIS WOOD PELLET STOVE IS NOT PROPERLY INSTALLED, A HOUSE FIRE MAY RESULT.

FOR YOUR SAFETY, FOLLOW THE INSTALLATION DIRECTIONS.

CONTACT LOCAL BUILDING OR FIRE OFFICIALS ABOUT RESTRICTIONS AND INSTALLATION INSPECTION REQUIREMENTS IN YOUR AREA.

PLEASE READ THIS ENTIRE MANUAL BEFORE INSTALLATION AND USE OF THIS WOOD PELLET FUEL-BURNING ROOM HEATER. FAILURE TO FOLLOW THESE INSTRUCTIONS COULD RESULT IN PROPERTY DAMAGE, BODILY INJURY OR EVEN DEATH.

SAVE THESE INSTRUCTIONS FOR FUTURE REFERENCE

WARNING

THIS STOVE IS NOT INTENDED FOR USE IN COMMERCIAL APPLICATIONS.

THIS STOVE SHOULD BE INSTALLED BY AN AUTHORIZED SERVICE TECHNICIAN.

For updates and additional instructions, go to www.luckydistributing.com/Heat/documents/

RIKA: AN OVERVIEW

Portrait

Congratulations on your purchase of a quality wood pellet stove made by RIKA. You are now a member of a group of more than 100,000 RIKA owners. If you were not familiar with RIKA before your purchase, please allow us to introduce ourselves.

RIKA was founded more than 50 years ago in Micheldorf, Austria by Karl Riener and his family. From a small company, specializing in hand made wrought iron products, grew a large, well known company recognized today as RIKA Metallwarengesellschaft. We appreciate quality and feel that our company manufactures some of the finest pellet and wood burning stoves available in today's marketplace.



Unique designs and emphasis on quality, performance and superior workmanship have made us a leading stove manufacturer in Europe. State of the art processes, such as; robotic welding, laser cutting and complete micro-processor control systems, allow us to produce a final product that we feel is unequalled.

In addition to pellet stoves, we are also known for our high quality wood-burning stoves, wood-burning cook stoves, freestanding fireplaces, and water heater units. RIKA also produces a large variety of other metal products for international corporations.

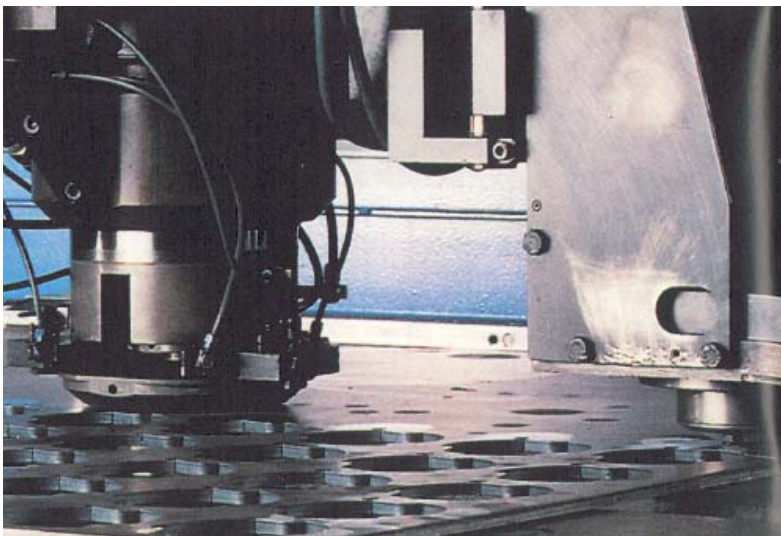

In 1988, RIKA began to introduce its products into the United States under the trade name Austroflamm. Rapid growth in the U.S. is directly attributed to the quality and unique design of the RIKA line of pellet stoves. Attention to detail has given us the nickname in the United States as the “Mercedes of the Pellet Stove Industry”.

SAFETY PRECAUTIONS

The word “stove”, as used in this manual, means the Integra Freestanding wood pellet stove.

READ THESE SAFETY PRECAUTIONS BEFORE INSTALLING OR USING STOVE.

The RIKA INTEGRA freestanding wood pellet stove must be properly installed in order to prevent the possibility of a house fire. For your own safety, you must adhere strictly to the installation instructions. Contact your local building officials to obtain a permit and information on any installation restrictions and inspection requirement in your area. Failure to follow these instructions could result in property damage, bodily injury or even death.

WARNING

BURN WOOD PELLET FUEL ONLY! NEVER BURN ANY OTHER FUEL SUCH AS PAPER, SOLID WOOD OR CHARCOAL!

DISPOSAL OF ASHES

Ashes removed from the stove may be hot. Ash must be placed in a metal container with a tight fitting lid. The closed container of ashes should be placed on a noncombustible floor or on the ground, well away from all combustible materials, pending final disposal. If the ashes are disposed of by burial in soil or otherwise locally dispersed, they should be retained in the closed container until all cinders have been thoroughly cooled.

Do not use gasoline, gasoline-type lantern fuel, kerosene, charcoal lighter fluid or similar liquids to start or “freshen up” a fire in this stove. Keep these flammable liquids well away from this stove when it is in use.

NOTE: Disconnect power before performing any maintenance or cleaning on your stove.



The manufacturer recommends that a computer-grade surge suppressor be used with this stove.

The stove’s exhaust system works with negative combustion chamber pressure and a slightly positive chimney pressure. It’s crucial that the air intake and exhaust system are air tight and installed correctly.

Do not make any alterations to the stove design. Only use factory authorized parts when performing service or making repairs. Design alterations or use of non-factory authorized parts could cause damage to your stove, and could result in a fire. Any service or repairs should be performed only by an authorized service technician.

Build-up of dust, soot, or creosote in the chimney connector and in the exhaust vent can cause a house fire. Although build-up will be minimal with correct operation, it is advisable to inspect the chimney connector and exhaust vent on a regular basis, and clean if necessary, at least once per heating season.

When operated properly, the stove cannot be over heated. However, continuous operation at maximum burn may shorten the life of the electrical components and is not recommended.

SAFETY PRECAUTIONS

THIS STOVE IS DESIGNED SPECIFICALLY FOR USE WITH PELLETIZED FUELS ONLY!

**HOT WHILE IN OPERATION!
KEEP CHILDREN, CLOTHING AND FURNITURE AWAY FROM STOVE. CONTACT WITH STOVE MAY CAUSE SKIN BURNS.**

DO NOT COOK FOOD, HOT BEVERAGES, OR PLACE ANYTHING ON TOP OF STOVE.

DO NOT USE CHEMICALS OR FLUIDS TO START THE FIRE.

DO NOT BURN GARBAGE OR FLAMMABLE FLUIDES SUCH AS GASOLINE, NAPHTHA OR ENGINE OIL.

SOOT AND FLY-ASH FORMATION AND NEED FOR REMOVAL

During normal use, fly-ash will collect in the ventilation and restrict the flow of the flue gasses. Incomplete combustion, which occurs during startup, shutdown, or incorrect operation of the stove will lead to some soot formation which will collect in the ventilation system. The ventilation system should be inspected at least once every year to determine if cleaning is necessary.

The pellets burned in the stove are fed by an auger. This auger is driven by a high-torque motor. The auger is capable of causing serious injury to fingers. Keep pellets in the hopper at all times.

The auger may start at any time when the stove is running! Keep hands and fingers away from auger at all times as contact with auger may cause personal injury.

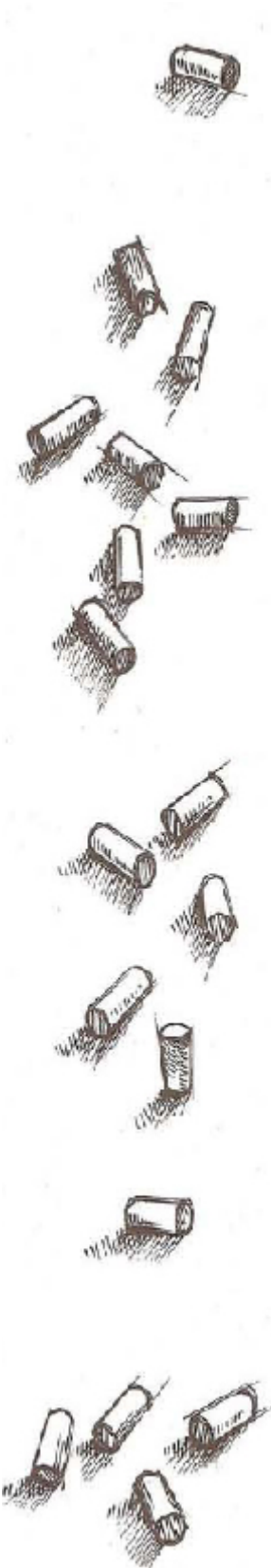

DO NOT ABUSE THE DOOR GLASS. USE CARE NOT TO STRIKE THE GLASS WITH OTHER OBJECTS. DO NOT ALLOW THE DOOR TO SLAM SHUT.

DO NOT OPERATE YOUR STOVE WITH BROKEN OR DAMAGED DOOR GLASS, OR WITH THE DOOR OPEN!!

IN ORDER TO KEEP PROPER DISTANCE FROM THE FLAME TO THE DOOR GLASS, DO NOT ALLOW THE STOVE TO OPERATE IN ANY MANNER THAT WOULD CAUSE COMBUSTION TO OCCUR OUTSIDE OF THE DESIGNATED BURN POT.

ALL GASKETS AND SEALS SHOULD BE KEPT IN GOOD CONDITION.

OPERATING YOUR STOVE WITH THE DOOR OPEN CAN CAUSE IT TO NOT OPERATE EFFICIENTLY, CAN CAUSE SMOKE DETECTORS TO ACTIVATE, CAN ALLOW SMOKE TO ENTER INTO THE LIVING AREAS OF YOUR HOME, CAN CAUSE BREATHING PROBLEMS, AND CAN LEAD TO A HOUSE FIRE.

SAFETY TESTING

The RIKA Integra Pellet Stove has been independently tested and listed with OMNI-Test Laboratories, Inc. in Beaverton, Or., an accredited testing laboratory, in accordance with the specifications and procedures outlined in ASTM E1509 "Standard Specifications for Room Heaters, Pellet Fuel-Burning Type", ULC/ORD C1482, and ULC S627. (The safety listing label is on the back of the stove.)



This stove has been tested and listed for residential installation according to standards in place at the time of testing.

OMNI SAMPLE LABEL FOR INTEGRA FREESTANDING PELLET STOVE

AUSTROFLAMM INTEGRA F/S

Manufactured for:
Lucky Distributing, Inc.
8111 NE Columbia Blvd.
Portland, OR 97218

Tested &
Listed By



Beaverton
Oregon USA

OMNI-Test Laboratories, Inc.
Report No. 313-S-03-2

Model: **Integra**
Tested To: **ASTM E 1509-04,
ULC C1482
ULC S627**

Serial No.

DO NOT REMOVE THIS LABEL
Made in Austria

Type Of Fuel: **Approved Pellets Only**

Date of Manufacture/Date de Fabrication

2006	2007	2008	Jan	Feb	Mar	Apr	May	Jun	Jul	Aug	Sep	Oct	Nov	Dec
<input type="checkbox"/>	<input type="checkbox"/>	<input type="checkbox"/>	<input type="checkbox"/>	<input type="checkbox"/>	<input type="checkbox"/>	<input type="checkbox"/>	<input type="checkbox"/>	<input type="checkbox"/>	<input type="checkbox"/>	<input type="checkbox"/>	<input type="checkbox"/>	<input type="checkbox"/>	<input type="checkbox"/>	<input type="checkbox"/>

**CONTACT YOUR LOCAL BUILDING OR FIRE OFFICIALS
ABOUT RESTRICTIONS AND INSTALLATION INSPECTION IN YOUR AREA**

Listed Room Heaters, Solid Fuel Type

Also Suitable for Mobile Home Installations Pursuant to (UM) H84-HUD

Configuration: **Integra**

"PREVENT HOUSE FIRES"

Install and use only in accordance with manufacturer's installation and operating instructions and your local building codes.

CAUTION: Special methods are required when passing chimney through a wall or ceiling, refer to local building codes. Do not connect this unit to a chimney flue serving another appliance.

Inspect and clean exhaust venting system frequently.

Keep viewing and ash removal doors tightly closed during operation.

WARNING: (MOBILE HOME) An outside air inlet must be provided for combustion and be unrestricted while unit is in use. Do not install appliance in a sleeping room.

For use with Pellet Fuel Only

Components Required for Residential Installation: Listed Pellet Vent.

NOTE: Replace glass only with 5 mm ceramic or NEOCERAM.

Electrical Rating: 120 VAC, 60 Hz

DANGER: Risk of electrical shock.

Disconnect power before servicing unit.

Do not route power cord beneath heater.

Components Required for Mobile Home Installation: Outside Air Kit.

INPUT RATING: This pellet fired appliance has been tested and listed for use in manufactured home in accordance with Oregon Administrative Rules 814-23-900 through 814-23-909.

**Minimum Clearance to Combustible Materials (in inches and mm)
Degagements Minimaux aux Matières Combustibles (pouces et mm)**

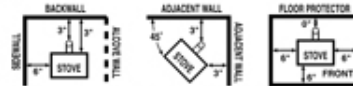

Floor protector must be non-combustible material extending beneath heater and to the front/sides/rear as indicated.
Le protecteur de sol doit être fait d'un matériau non combustible placé sous le foyer et se prolongeant vers l'avant, l'arrière et les côtes du foyer.

Alcove Dimensions: 55" min. height, 41" min. width, and 24" max. depth.
Dimensions de l'alcôve: Hauteur min. 51 po, largeur min. 41 po, profondeur max. 24 po.

Unit to Sidewall / de l'appareil au mur latéral 6" / 153 mm

Unit to Backwall / de l'appareil au mur arrière 3" / 75 mm

Unit to Alcove Ceiling or Mantle / de l'appareil au plafond d'alcôve ou linteau 17" / 432 mm

Unit Corner to Diagonal Wall / du coin de l'appareil au mur en diagonale 3" / 75 mm

Input Rating / de l'admission nominale 41,350 Btu/hr

SIDEWALL = MUR LATÉRAL
ADJACENT WALL = MUR ADJACENT
ALCOVE WALL = MUR D'ALCÔVE
FRONT = DEVANT
BACKWALL = MUR ARRIÈRE
STOVE = POËLE
FLOOR PROTECTION = PROTECTION DE SOL

**PRENDRE CONTACT AVEC LE BUREAU DE LA CONSTRUCTION LOCAL ET LE
SERVICE DES INCENDIES POUR CONNAÎTRE LES RESTRICTIONS ET LES
INSPECTIONS REQUISES DANS VOTRE REGION**

Répertorié comme appareil de chauffage de pièce à carburant solide Convient aussi aux maisons mobiles conformément au (UM) H84-HUD

"ÉVITEZ LES INCENDIES" N'installez et n'utilisez qu'en suivant les instructions du fabricant concernant l'installation et le fonctionnement ainsi que le règlementation locale de construction.

MISE EN GARDE: Le passage d'une cheminée à travers un mur ou un plafond demande une méthode spéciale d'installation. Consultez les codes de construction et les directives d'installation du fabricant. Ne reliez pas cet appareil au conduit d'un autre appareil.

Inspectez et nettoyez fréquemment le dispositif d'évacuation des gaz.

Maintenez les portes de visualisation et de retrait des cendres complètement fermées pendant le fonctionnement.

AVERTISSEMENT: (MAISON MOBILE) Une admission d'air extérieur de combustion sans obstruction doit être assurée quand l'appareil est en utilisation. N'installez pas l'appareil dans une chambre à coucher.

N'utilisez que des granulés de bois.

Composantes requises pour l'installation résidentielle: Évent répertorié pour les appareils à granulés.

ADMISSION NOMINALE: Cet appareil de chauffage à granulés a été testé et répertorié pour l'usage dans des maisons pré-fabriquées, conformément aux règlements administratifs de l'Oregon 814-23-900 à 814-23-909.

Carburant: Boulettes approuvées seulement.

REMARQUE: Ne remplacez la vitre qu'avec une vitre de ceramique ou NEOCERAM de 5 mm.

Alimentation Électrique: 120 VAC, 60 Hz.

DANGER: Risque de choc électrique. Couper le courant avant de faire l'entretien. Ne pas acheminer le cordon sous l'appareil.

Composante requise pour l'installation dans une maison mobile: Assemblage d'air extérieur.



CAUTION: HOT WHILE IN OPERATION. DO NOT TOUCH. KEEP CHILDREN AND CLOTHING AWAY. CONTACT MAY CAUSE SKIN BURNS. SEE NAMEPLATE AND INSTRUCTIONS. KEEP FURNISHINGS AND OTHER COMBUSTIBLE MATERIALS A CONSIDERABLE DISTANCE AWAY FROM THIS APPLIANCE. OPERATE THIS UNIT ONLY WITH THE FUEL HOPPER LID CLOSED.

FAILURE TO DO SO MAY RESULT IN EMISSION OF PRODUCTS OF COMBUSTION FROM THE HOPPER UNDER CERTAIN CONDITIONS. MAINTAIN HOPPER SEAL IN GOOD CONDITION. DO NOT OVERFILL THE HOPPER.

ATTENTION: CHAUD LORS DE L'OPÉRATION. NE PAS TOUCHER. GARDEZ LES ENFANTS ET LES VÊTEMENTS LOIN DE L'ESPACE DÉSIGNÉ DE L'INSTALLATION. PEUT CAUSER DES BRÛLURES À LA PEAU. VOIR L'ÉTIQUETTE ET LES INSTRUCTIONS. GARDEZ LES MEUBLES ET LES MATÉRIAUX COMBUSTIBLES LOIN DE L'ESPACE DÉSIGNÉE DE L'APPAREIL. NE FAITES FONCTIONNER CET APPAREIL QU'AVEC LE COUVERCLE DE LA TRÉMIE DE COMBUSTIBLE FERMÉ. DANS LE CAS CONTRAIRE, DES ÉMISSIONS DE PRODUITS DE COMBUSTION PEUVENT S'ÉCHAPPER DE LA TRÉMIE DANS CERTAINES CONDITIONS. MAINTENEZ LE JOINT DE LA TRÉMIE EN BON ÉTAT. NE REMPLISSEZ PAS EXCESSIVEMENT LA TRÉMIE.

MAIN CONTROL BOARD/SPECIFICATIONS

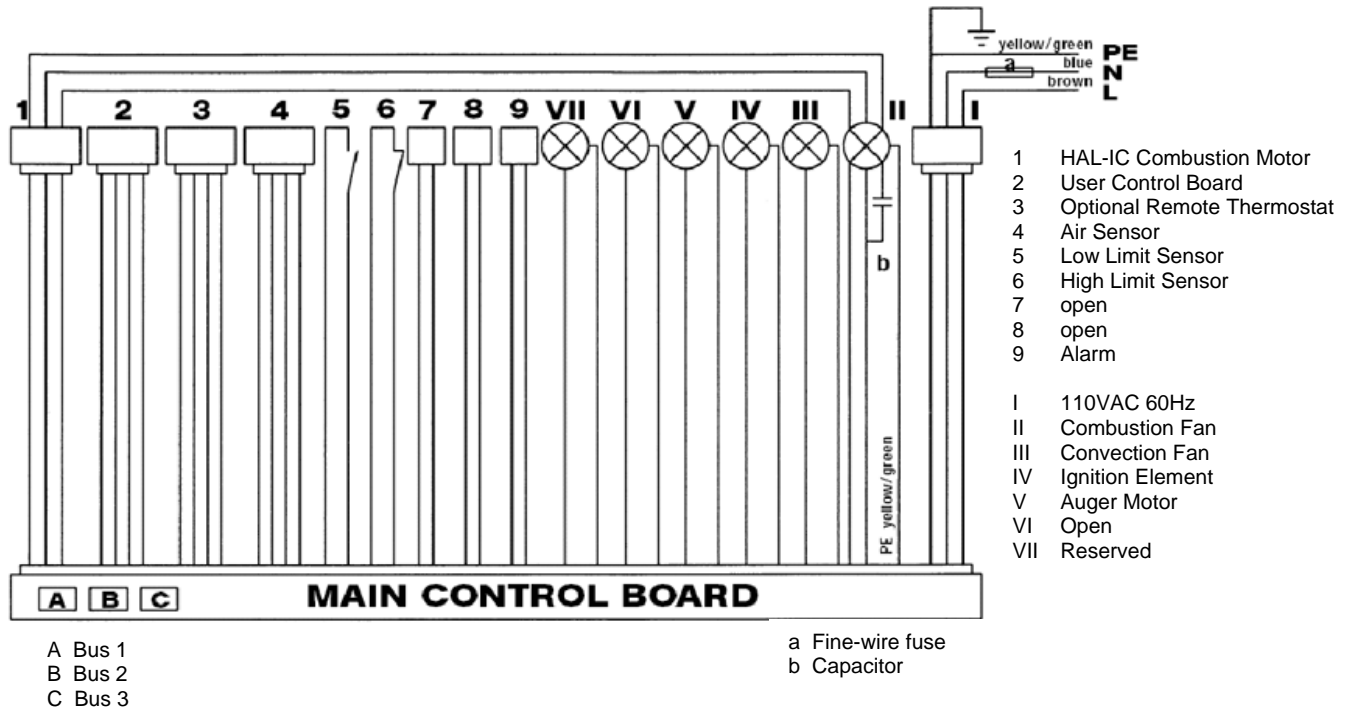

Specifications & Capacities	
Height (inches)	37-1/2"
Width (inches)	28-1/2"
Depth (inches)	25-3/4"
Weight (lbs)	375
Exhaust Outlet	3"
Heating Capacity	9,000 to 42,000 BTUs
Fuel Consumption	1-5 lbs per hour
Pellet Hopper Capacity	145lbs
Power Supply	110 V, 60 Hz
Average Electrical Power Consumption	< 100 W
Fuse	3.15 A

PARTS ILLUSTRATION

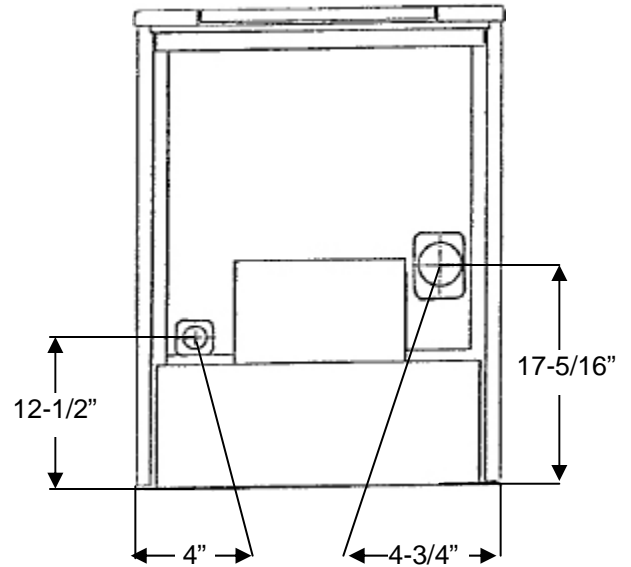
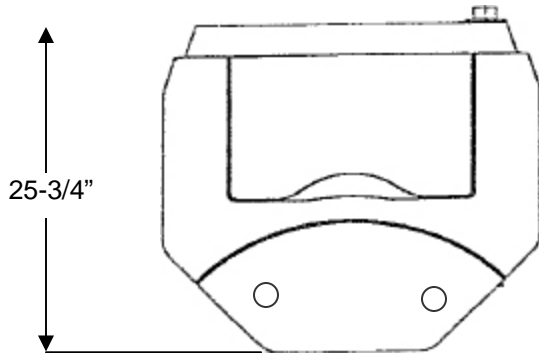
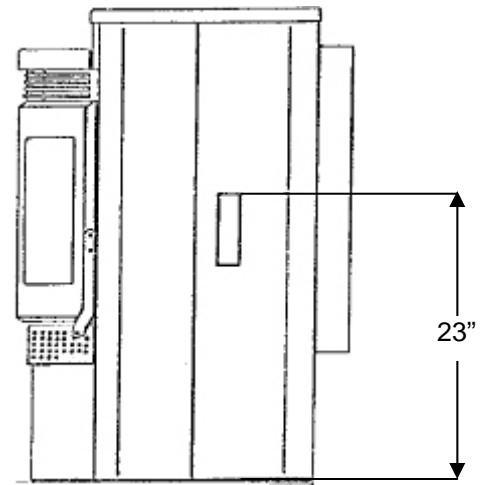
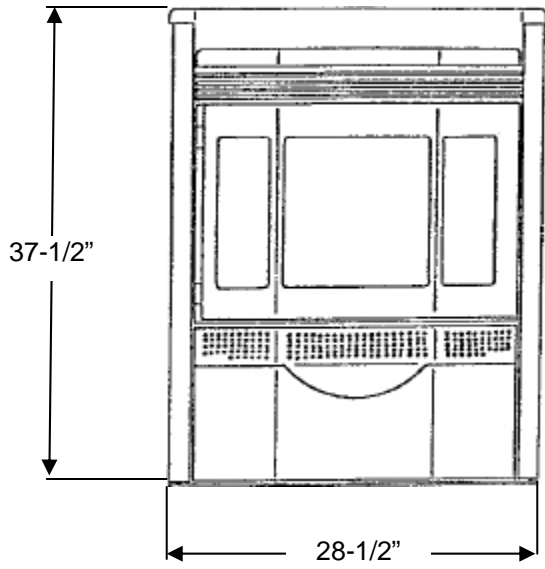

PARTS ILLUSTRATION

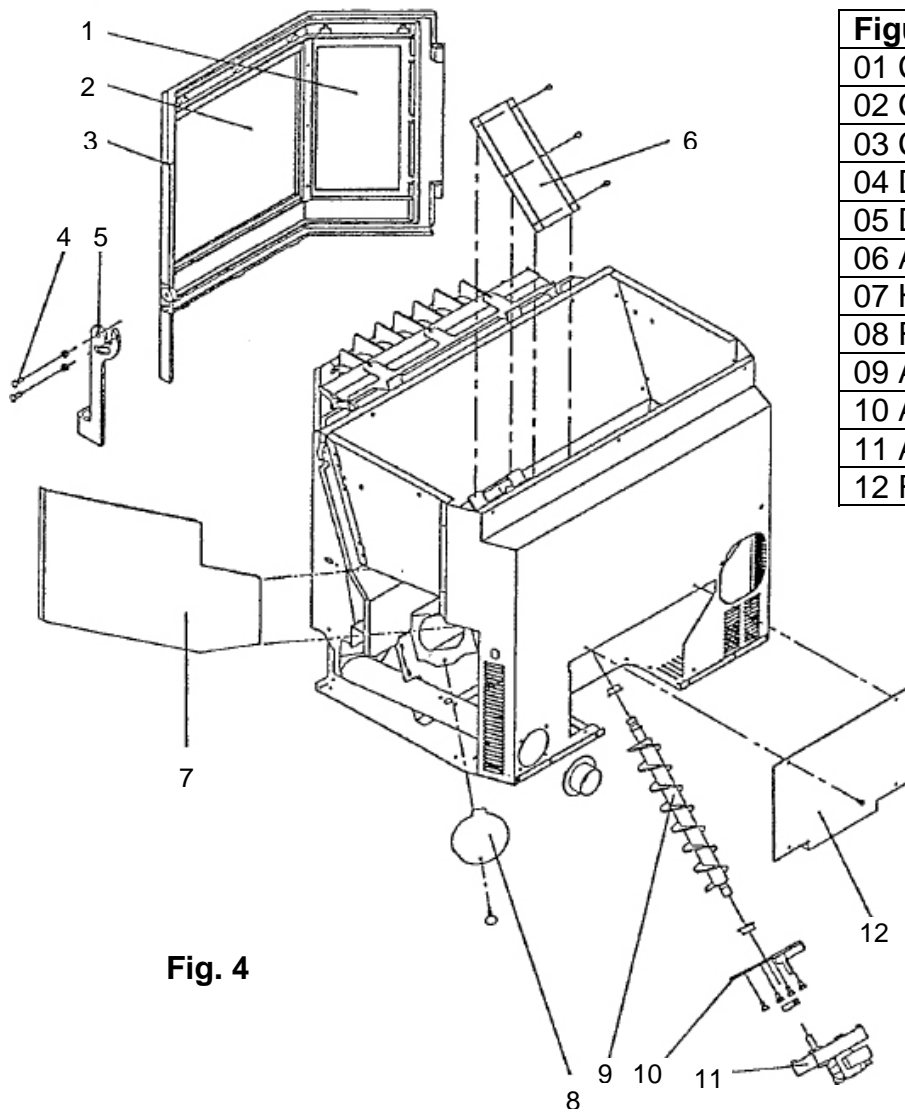

Figure 4	
01	Ceramic Side Glass (part #Z14847)
02	Ceramic Front Glass (part #Z14846)
03	Cast Iron Door
04	Door Handle Bolt
05	Door Handle
06	Auger Cover
07	Heat Shield
08	Rear Heat Exchanger Access Plate
09	Auger
10	Auger End Plate
11	Auger Motor
12	Rear Cover Plate

Fig. 4

PARTS ILLUSTRATION

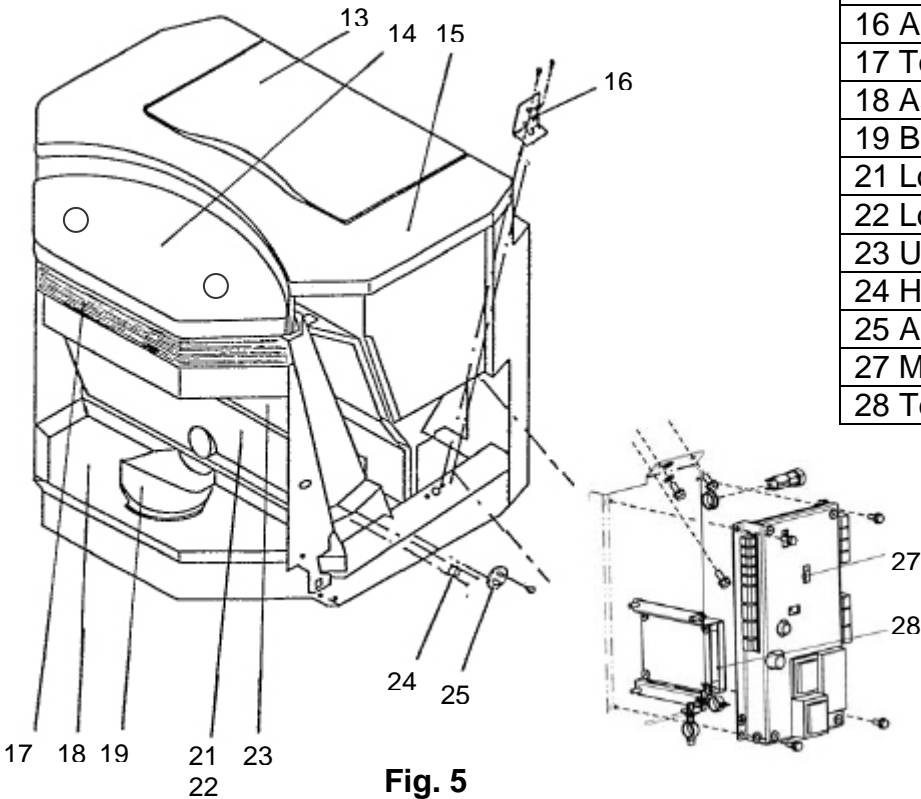

Figure 5	
13	Hopper Lid
14	Cast Top
15	Hopper Cover
16	Air Sensor
17	Top Grill
18	Ash Pan
19	Burn Pot
21	Lower Cast Wall
22	Lower Cast Wall Gasket
23	Upper Cast Wall
24	High Limit Switch
25	Adjustable Door Latch
27	Main Circuit Board
28	Tele Control (Europe only)

Fig. 5

Figure 6	
29	Power Cord
30	Flue Adapter
31	Connecting Band
32	Low Limit Switch
33	Low Limit Gasket
34	Combustion Motor Housing
35	Combustion Motor
36	Convection Fan
37	Upper Door Hinge
38	Lower Door Hinge
39	Igniter Element
40	Igniter Bracket

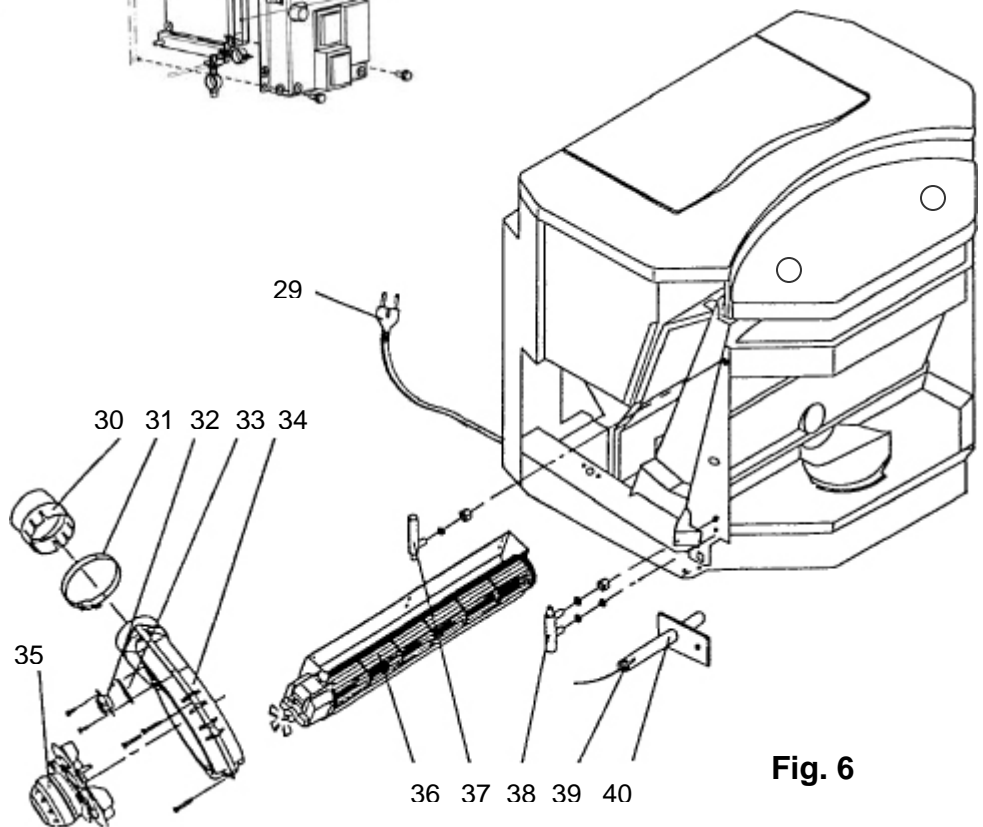

Fig. 6

PARTS ILLUSTRATION

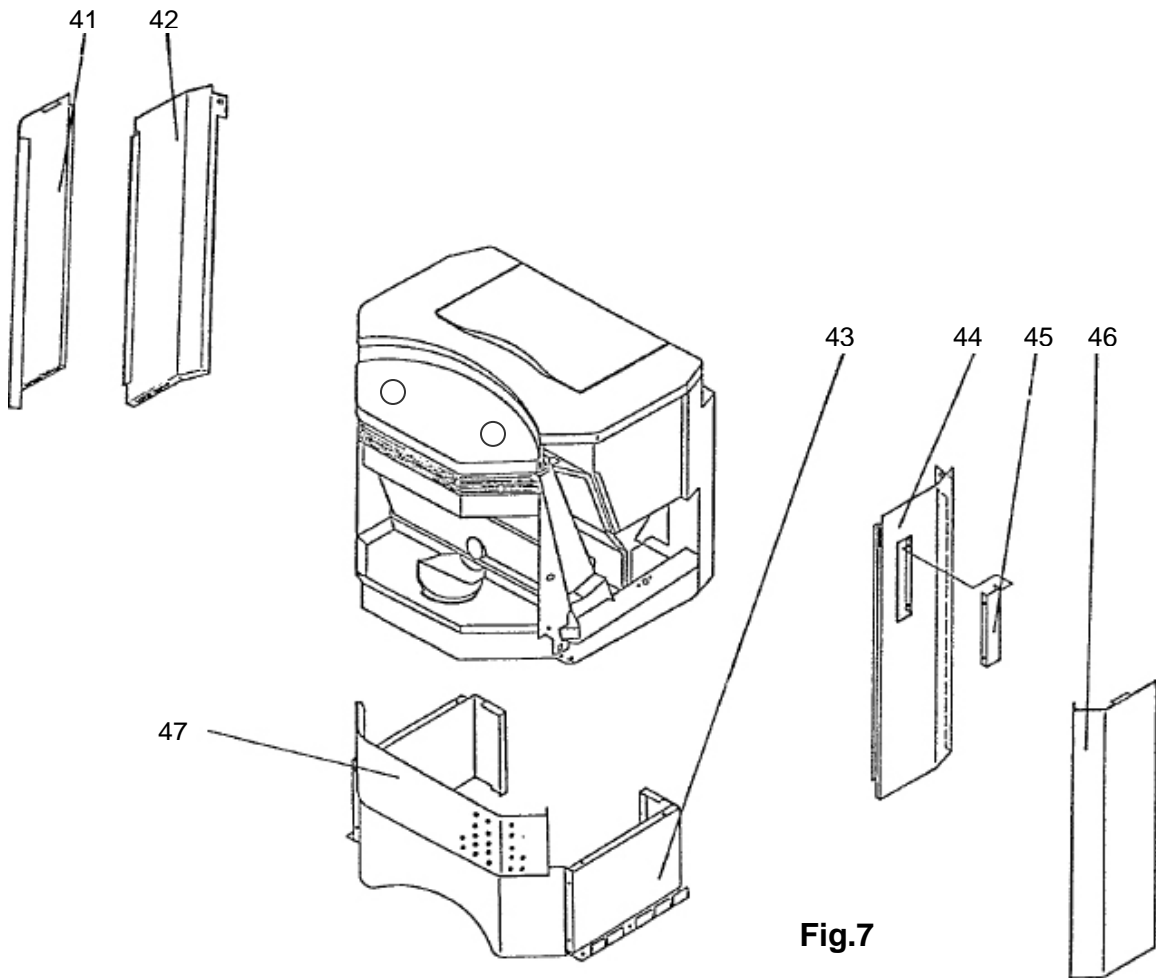

Fig.7

Figure 7
41 Left Front Side Cover
42 Left Rear Side Cover
43 Pedestal
44 Right Side Rear Cover
45 User Control Board
46 Right Side Front Cover

AUTOMATIC SAFETY FUNCTIONS

FOLLOWING A POWER FAILURE

In the case of a power failure, the stove returns to the same operating mode it was in at the moment the power failed.

- **ON-Mode (Manual mode)**
If the stove was turned on in manual mode, the stove will turn itself back on when power resumes. The control display will read ST-21 (Start Phase) and then will display ON at the conclusion of the 21-minute startup cycle.
- **TM-Mode (Automatic mode)**
If the stove was in the TM mode (controlled by your preset start and stop time schedule), the stove will resume the preset schedule when power resumes. If power resumes at a time when the stove is schedule to be off, the stove will remain off.
- **SB-Mode (Standby mode)**
If the stove was off but set in the standby mode, the control switches back into SB-Mode approximately 2-seconds after the power resumes. In this setting, the stove will not turn itself back on.

NOTE: During a power failure, smoke can escape from the stove. This is normal in a power outage. If this occurs, open windows and doors to alleviate the smoke.

OVERHEATING

If the stove overheats, an excess temperature safety switch (Hi-Limit) will shut-off the pellet feed and force the stove to shut down.

ATTENTION: If overheating has occurred, maintenance/cleaning and inspection must be performed by an authorized service technician prior to subsequent use.

LOW OPERATING TEMPERATURE

If the stove cools down below a minimum allowable temperature, the stove will go into automatic shut down mode. This may be caused by low pellet feed or an empty hopper.

AUGER MOTOR SHUT-OFF

When the hopper lid is open, the auger motor will stop feeding pellets. This safety feature is installed to protect you from potential injury should you stick your finger or any foreign object into the auger shaft.

The auger will only operate when the hopper lid is closed.

INSTALLATION

This stove should be installed by an authorized service technician.

Before installing, contact your local building or fire officials about restrictions and installation inspection requirements in your area. Manufacturer and distributor have no control over the installation of the stove and assume no responsibility for any special, incidental or consequential damages caused by improper installation.

The following installation guidelines must be followed to ensure conformity with both the safety of this stove and with local building codes.

FLOOR PROTECTION

The stove must be installed on a non-combustible surface. A single-layer 3/8" non-combustible floor area, or equivalent is required.

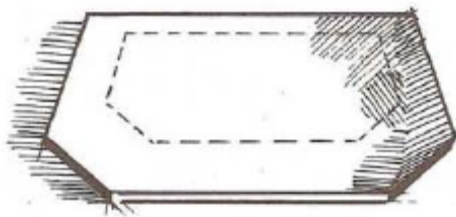

EXHAUST SYSTEM DESIGN GUIDELINES

The stove must be connected to an approved three or four inch pellet vent chimney. See Installation Instructions for more information.

DO NOT INSTALL A FLUE DAMPER IN THE EXHAUST VENTING OF THIS STOVE!

DO NOT CONNECT THIS STOVE TO A CHIMNEY FLUE SERVING ANOTHER APPLIANCE!

The exit terminal must be located no less than 48 inches from any opening through which combustion products could enter the building (i.e. windows and doors), no less than 24 inches from an adjacent building, and no less than seven feet above grade, when located adjacent to public walkways. It must be arranged so that exiting flue gasses will not be a hazard to people, overheat combustible structures, or enter into any building.

DO NOT CONNECT TO ANY AIR DISTRIBUTION DUCT OR SYSTEM!

Keep brush, plants, and shrubs at least 36" away from the vent termination.

The total length of horizontal vent must not exceed five feet. The "PL" vent exhaust system must be installed and sealed with three screws per joint. The chimney manufacturer's installation procedures must be followed. In addition, pipe connections, joints, and all pipe seams within the home should be sealed with high-temperature silicone sealer, and (RTV) aluminum tape.

ELECTRICAL CONNECTION

The stove is supplied with a 7' to 8' power cord. This cord must be connected to a properly polarized, normal 110v, 60Hz grounded electrical outlet. The average power consumption is approximately 100 watts under normal operation. During the ignition process (duration of 12 minutes), power consumption is approximately 300 watts. The power cord must be run so that any contact with hot or sharp-edged external surfaces is avoided.

COMBUSTION AIR

The combustion process requires oxygen. As a rule, the combustion air is taken from the living area in the home. The air taken from the living area must be re-introduced. Tight fitting windows and doors could result in insufficient air flow into the house for proper combustion. This situation becomes more problematic due to additional ventilation in the house such as kitchen or bathroom exhaust fans. An additional outside air source may be necessary for adequate air and optimum combustion.

VENT CLEARANCES

Install all vent at clearances specified by the vent manufacturer.

CANADIAN INSTALLATION

Where passage through a wall, or partition of combustible construction is desired, the install shall conform to CAN/CSA-B365.

Clearances may only be reduced by means of approved regulatory authority.

INSTALLATION

CLEARANCES TO COMBUSTIBLES

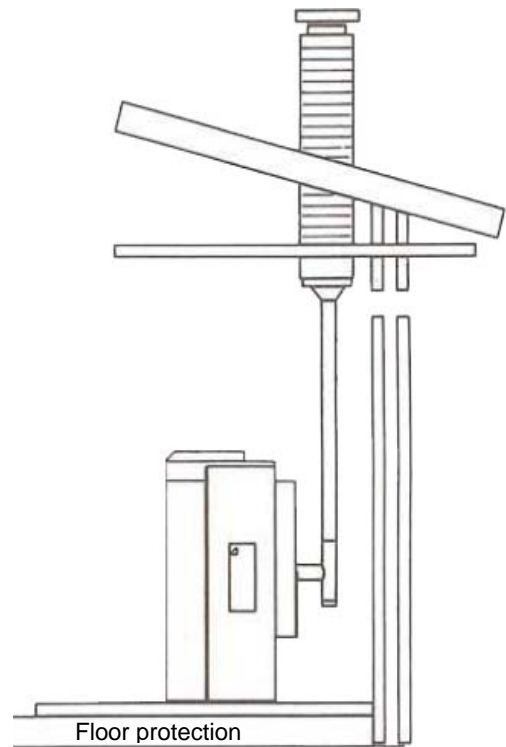
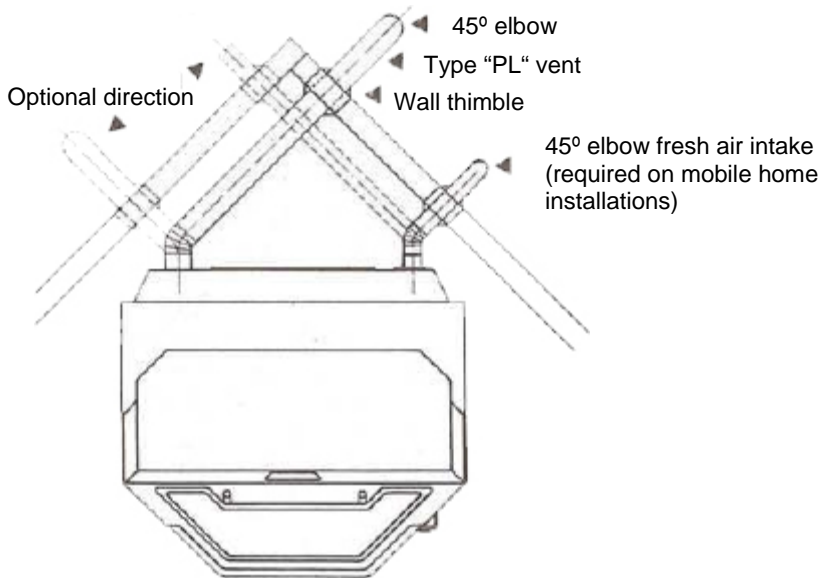
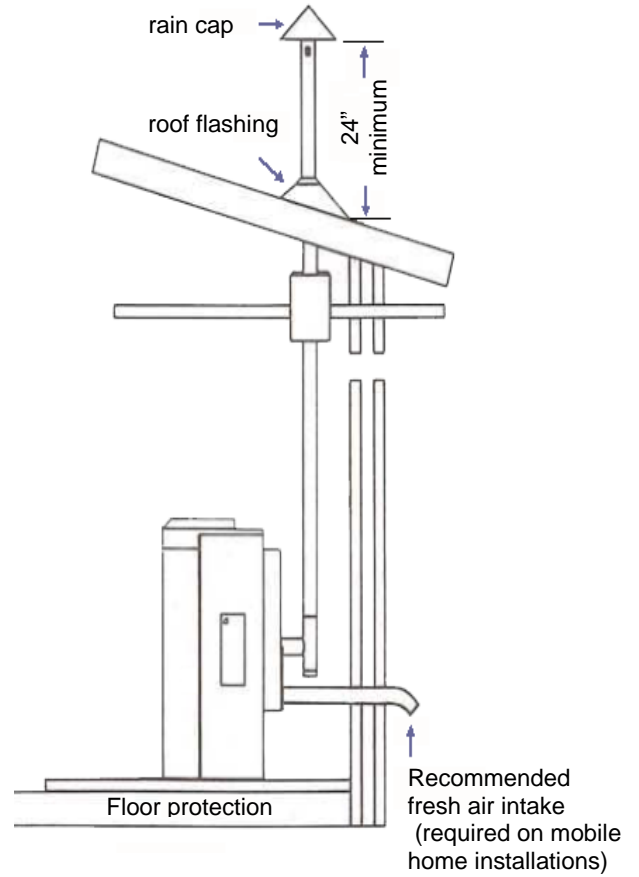
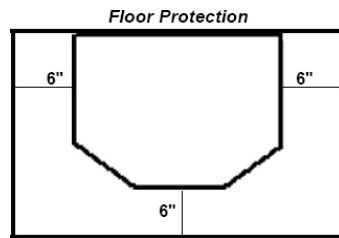
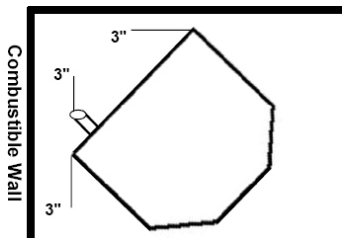
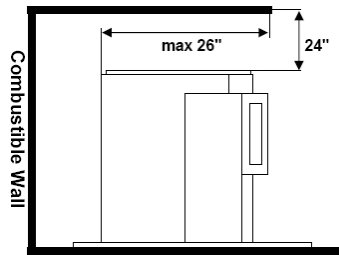
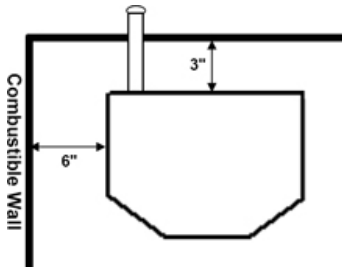

INSTALLATION

Additional Venting Instructions

Caution: Optimum safety, combustion and burn quality cannot be achieved if these guidelines are not followed. Failure to follow these guidelines will void your warranty.

Caution: All chimney connectors must be kept clean and in good condition.

Caution: Do not use make-shift methods or compromises in the installation.

- Only use ventilation components designed and approved for use with a pellet stove.
 - Although not recommended, straight out horizontal venting is acceptable, however if a vertical termination is employed, minimum vertical rise (to termination point) must be no less than the total height of the stove.
 - Each 90° angle or T-connector adds an effect of five additional feet of pipe length. Each 45° angle adds an effect of three additional feet of pipe length.
 - 4" venting is required in all installations at or above elevations of 2500 feet.
 - 4" venting is required in all installations where the total length of venting is equal to or greater than 20 feet including the effective length of any angles.
- The maximum length of any venting configuration should not exceed 30 feet total, including the effective lengths of any angles.
 - No portion of the ventilation system shall pass through an attic or roof space, closet or similar concealed space, or a floor or ceiling.
 - Follow all manufacturers' ventilation installation instructions.

MOBILE HOME INSTALLATION

In addition to standard installation instructions, the following requirements are mandatory for installation in a mobile home:

1. The unit must be permanently bolted to the floor.
2. The unit must have a permanent outside air source.
3. The unit must be permanently electrically grounded to the steel chassis of the home.
4. Use silicone to create an effective vapor barrier at the location where the chimney or other component penetrates to the exterior of the structure.

For use in mobile or manufactured homes, the stove must be installed in accordance with the Manufactured Home and Safety Standard (HUD), CFR32 80, Part 24.

Design guidelines for outside air connection

1. A connection to the outside is REQUIRED for mobile home installations.
2. Only metal pipe with a minimum two inch diameter is approved for use as an outside air connection (straight or flexible). PVC pipe or aluminum pipe is NOT approved and should never be used.
3. The air inlet must be terminated with a vertical 90 degree bend (down) or with a wind hood.

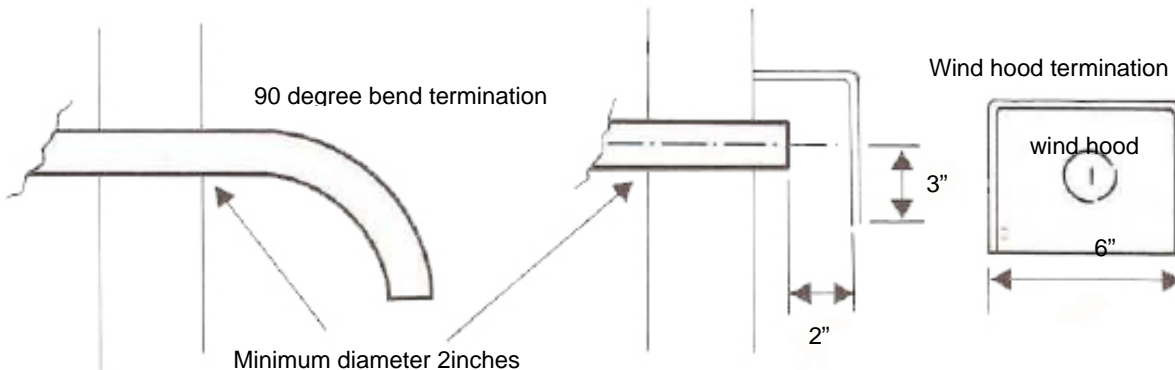

WARNING:
DO NOT INSTALL IN SLEEPING ROOMS.

COMBUSTION AIR MUST COME FROM THE OUTSIDE OF THE MOBILE HOME.

CAUTION:
THE STRUCTURAL INTEGRITY OF THE MANUFACTURED HOME FLOOR, WALL AND CEILING / ROOF MUST BE MAINTAINED.

THIS STOVE IS TO BE CONNECTED TO A FACTORY-BUILT-CHIMNEY CONFORMING TO CAN/ULC-S629, STANDARD FOR FACTORY-BUILT CHIMNEYS.

COMPLETELY REMOVE EXTERIOR PORTIONS OF CHIMNEY PRIOR TO MOVING THE MOBILE HOME.

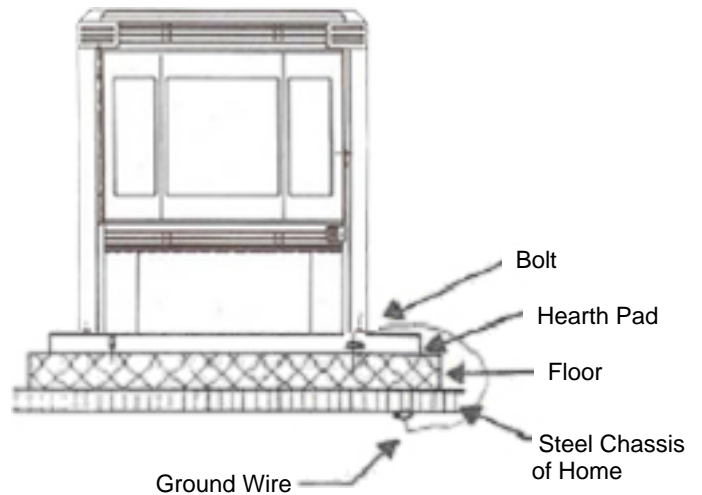

4. Blockage, excessive length, or bends in the air intake will starve the unit of combustion air.

A 90 degree bend is equivalent in restriction to approximately 30 inches of straight pipe

A NEW HEATING PHILOSOPHY

In today's world, anyone manufacturing and marketing heating appliances has more than just the responsibility of producing a quality, safe product. It is essential that wood heating appliances apply technology which is environmentally friendly and, at the same time, extremely efficient.

RIKA is 100% committed to this obligation, and continues to do research and development in pellet stove combustion technology. This gives you, the consumer, assurance that you are buying the most advanced product in the marketplace.

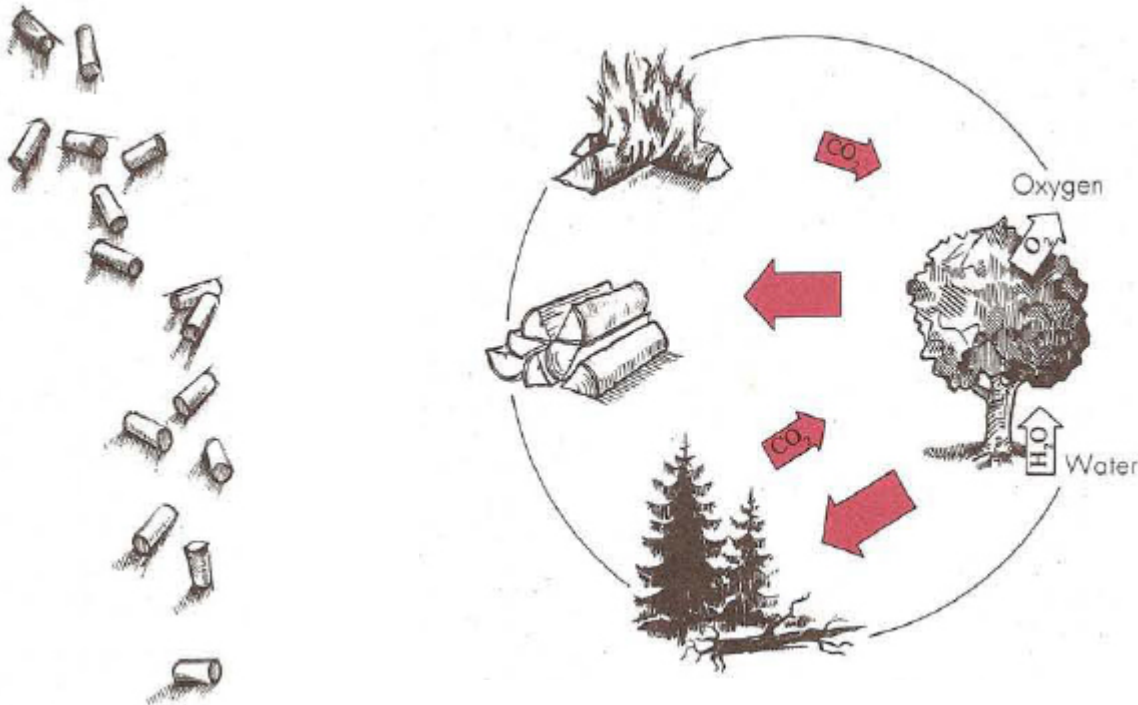

WHY HEAT WITH PELLETS?

Chemically speaking, burning wood is the same process as wood rotting by itself. Rotting wood, as well as burning wood, releases CO_2 that trees need to grow and, therefore, burning wood has no impact on the CO_2 cycle. Heating with pellets means that the burning process is very carefully controlled, and wood is added to the combustion process only in precise quantities. This results in the optimized and environmentally friendly incineration of wood.

In the past, waste wood products were simply discarded into local landfills to rot. Heating with pellets is an economical and a distinctly advantageous alternative to dumping. It is a natural and intelligent method of recycling. Heating with your RIKA pellet stove is designed to be easy and user-friendly. Because of its exceptionally large hopper, low pellet consumption, and very simple control panel, your RIKA pellet stove is, indeed, easy and convenient to operate.

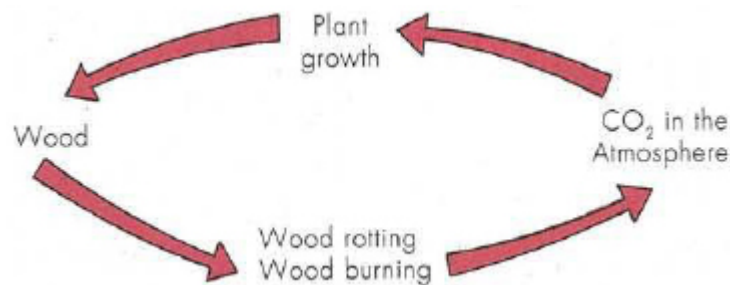

WHAT ARE PELLETS

The RIKA INTEGRA is a pellet stove designed to burn wood pellets. Pellets are made of waste material from saw mills, woodworking operations, as well as dead wood from forestry operations. The wood pellet industry is organized through the association of the Pellet Fuel Institute, and it is recommended that only PREMIUM wood pellets, manufactured to the standard set by the P.F.I. be used with this pellet stove. All pellets made to these standards are labeled with an official P.F.I. registration number on the bag. This guarantees the consumer that the fuel is certified as to moisture and ash content.

The P.F.I. allows two grades: Standard and Premium quality pellets. The important difference in these pellet grades is their ash content.

Premium quality: 1% or less ash content

Standard quality: Up to 3% ash content

A higher ash content in the fuel means more combustion residue which means more frequent cleaning intervals. (see the Routine Maintenance & Cleaning section).

ASH

It is highly recommended that you use the lowest ash-content fuel available. Using fuel with 3% ash content may require that the stove be cleaned as often as every one to two days. Fuel with 1% ash content may only require cleaning once every one to two weeks.

The ash produced while your stove is operating, since it is a completely natural product, makes an excellent fertilizer for all of your garden plants. However, it should be aged and mixed with water before use.

Please note that use of improper fuels will void your warranty and may cause damage or seriously impact the performance of your stove.

The current P.F.I. standards for residential pellet fuels are as follows:

	Standard Quality	Premium Quality
Heating Value	8,200 BTU/lb. (minimum)	8,200 BTU/lb. (minimum)
Bulk Density	40lb/ft ₃ (minimum)	40lb/ft ₃ (minimum)
Moisture Content	8% (maximum)	8% (maximum)
Ash Content	3% (maximum)	1% (maximum)
Size	¼" to 5/16" diameter 1-1/2" long (maximum)	¼" to 5/16" diameter 1-1/2" long (maximum)
Fines	0.5% maximum through a 1/8" screen	0.5% maximum through a 1/8" screen

Caution: Burning dirty or wet pellets, or pellets containing salt, can contaminate the environment, adversely affect the function of your pellet stove, and will void your warranty.

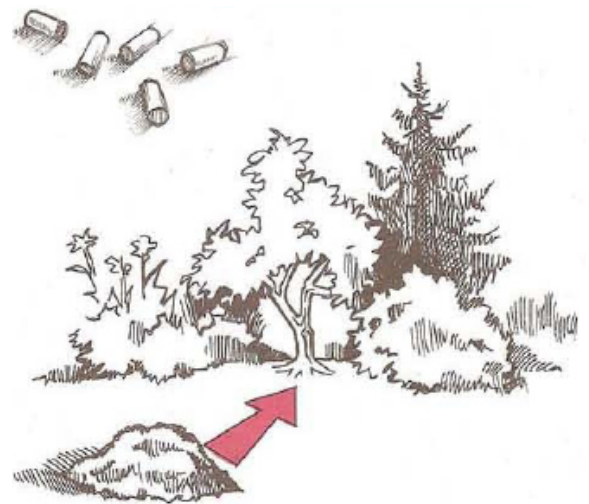

Caution: Embers may be embedded and hidden in the ash. Store in metal containers only!

STORING PELLETS

To guarantee that your pellets will burn without any problems, they should be stored in a dry and clean environment.

CAUTION: DO NOT STORE YOUR PELLETS WITHIN THE INSTALLATION CLEARANCES OR WITHIN THE SPACE REQUIRED FOR FILLING THE HOPPER OR REMOVING THE ASH.

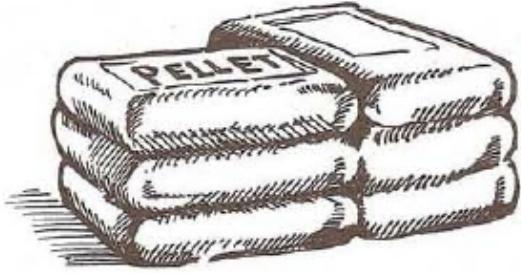

If you have any further questions regarding fuel for use in your RIKA pellet stove, please contact your dealer or the P.F.I.

Pellet Fuel Institute
1901 North Moore Street #600
Arlington, VA 22209
(703) 522-6778

CLINKERING

“Clinkering” is a normal process that takes place in the burn pot. A clinker is a solid substance that accumulates due to heat and silica working together and forming deposits during combustion. Silica is actually sand and is present in all pellet fuels along with a variety of other impurities. When clinkering takes place, these hard substances tend to accumulate and can adversely impact the performance of your stove as it cuts

off the air supply to the combustion process. The burn pot should be checked periodically for clinkers, and all hard substances should be removed to allow proper air flow through the bottom of the burn pot. It should be noted that even P.F.I. approved pellet fuels will cause some clinkering.

For more information about how often to clean your stove, see the Routine Maintenance & Cleaning section of this manual.

There is no warranty for damage or poor performance caused by the use of inferior or improper grades of pellet fuels. The stove manufacturer is not responsible for the performance of the stove due to the use of non P.F.I. approved pellet fuels.

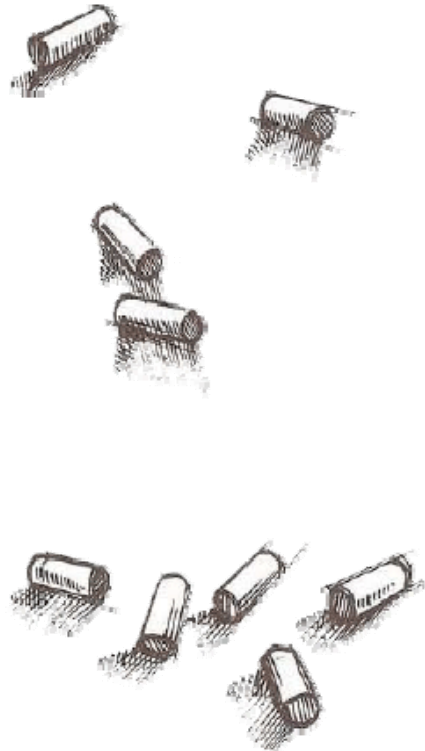
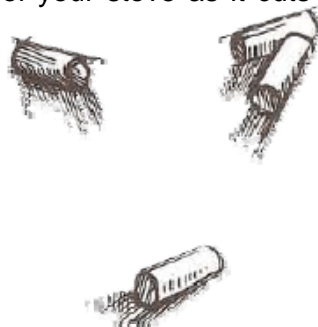

BASIC OPERATION

DO NOT start your stove until the venting installation is complete

NOTE: Your pellet stove is exclusively for burning pellets made from wood of a controlled quality. Non-pelletized solid fuels (straw, corn, chopped matter, etc.) should not be used. Failure to adhere to these guidelines will void your warranty.

NOTE: When operated correctly, your pellet stove will not overheat. Improper operation can shorten the life expectancy of the stove and its components.

ATTENTION: Your stove's automatic ignition system will not work properly if either the hopper lid or combustion door are open.

CONTROL UNIT PROGRAMMING AND FUNCTION

Your pellet stove is equipped with a modern programmable control board and control software. The owner can set all equipment functions via the control keypad which is found on the right hand side of the unit. The control board and software should only be altered by trained specialists. Improper or unauthorized changes to your stove, unless outlined in your owner's manual or this operating guide, will void your warranty.

Possible Operating Modes

Pressing ENTER on the control panel enables the user to change between each of the three different operating modes.

- Manual Mode - press the power button to turn the unit on and off.
- Automatic or Timed Mode (TM) - runs according to a schedule that you determine.
- Standby Mode (SB) - waiting for you to change to one of the other two modes by pressing the "Enter" button on the key-pad. No function, other than programming, can occur in this mode.

Control Keypad

All settings and functions can be regulated via this unit.

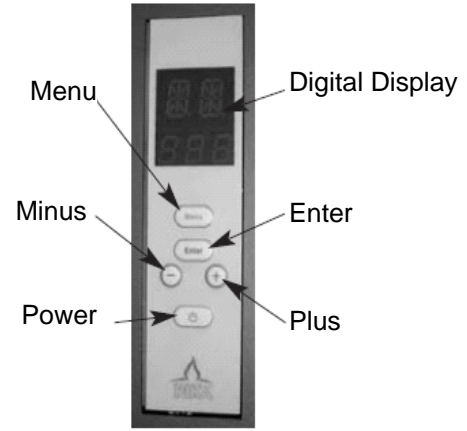

DISPLAY BOX

Displays the operating modes in illuminated letters and numbers.

MENU

Used for navigation in and to the different menu and sub-menu levels.

ENTER

Used for navigation through the main menus (SB, ON, TM) and for confirming user entries.

MINUS & PLUS

Used for lowering or increasing heat output levels and for changing program values.

POWER

Used for turning the unit on and off.

TURNING YOUR STOVE ON AND OFF

To operate your stove manually, place it into manual mode (see the "POSSIBLE OPERATING MODES" section).

Once in manual mode, the stove is turned on and off by pressing the power button. Heat output is controlled by pressing the "+" and "-" buttons.

Your RIKA pellet stove is equipped with an electronic ignition start-up system. Starter fluids or gels are not necessary and should never be used. Simply push the power button and the unit will ignite within a 12-minute period of time. Total start-up cycle time is 21 minutes.

STARTING / PROGRAMMING THE CONTROL

When the hopper is filled for the first time or if it is allowed to run empty, it can take up to two full start-up cycles for pellets to feed sufficiently into the burn pot.

Under these circumstances the stove may shut-down and display ER0, ERR or ERR/CL at the end of the start-up cycle. Re-start the stove and the feed rate should return to normal.

Initial Startup

Verify that there are pellets in the hopper, that the burn pot is empty and seated properly, and that the unit is plugged into a 110v grounded outlet.

SB Press the "ON/OFF" button. If the stove has never been turned on before, the display should read "SB".

NOTE: Your stove can be programmed while in any of the three modes. If it does not display "SB" in the display at this point, simply continue on to the next step.

NOTE: Your stove may turn on at this point.

You may now program your unit for your individual needs. You can set up to two start-up / shut-down cycles for each day of the week.

NOTE: When in programming mode, if no change is needed on a particular setting simply press enter to advance to the next setting.

MO Press the "MENU" button. The display should read "MO" for Monday.

**S1
6** Press the "ENTER" button. The display should read "S1" for the first heating period on Monday, the number represents the start time. Change the time by pressing the "+" or "-" keys. Confirm by pressing "ENTER".

NOTE: Start and end times are in military format (displays as 0 for midnight through 23 for 11pm).

**E1
8** The display should now read "E1" for the ending time of the first heating period on Monday. Change the time by pressing the "+" or "-" keys. Confirm by pressing

**S2
16**

The display should now read "S2" for the second heating period on Monday. Change the time by pressing the "+" or "-" keys. Confirm by pressing "ENTER".

**E2
20**

The display should now read "E2" for the end time of the second heating period on Monday. Change the time by pressing the "+" or "-" keys. Confirm by pressing "ENTER".

MO

The display should now read "MO".

TU

Press "MENU". The display should now read "TU" for Tuesday.

Repeat the prior steps to set the start and end times for each day of the week. "WE" Wednesday, "TH" Thursday, "FR" Friday, "SA" Saturday, "SU" Sunday.

**PS
75**

After entering the "E2" value for Sunday, press "MENU" and the display should read "PS".

"PS" represents the percentage of heat output that you want your stove to operate at when it is scheduled to be on (0% to 100%). 0% maintains flame with minimal heat, 100% produces maximum heat output.

Change the output setting by pressing the "+" or "-" keys. Confirm by pressing "ENTER".

**PE
OFF**

The display should now read "PE" for Power End. This represents the output level **between** the pre-programmed heating cycles that you just defined. In other words, what power level should the stove operate at between the end time of one cycle, and the start time of the next cycle.

Use the "+" or "-" keys to choose any level between 0% and 100%, or you can choose for your unit to turn off between cycles. Confirm your setting by pressing "ENTER".

PROGRAMMING THE CONTROL

CF
100

After pressing enter on the “PE” output setting, the display should read “CF” which represents the convection fan speed increase over normal. With this setting, the user has the option to increase the pre-set output of the convection fan. (**note:** this function only available in software v1.33 and higher)

The range is 100 to 150, where 100 (100%) stands for the software controlled normal convection fan operation based upon selected heat output level.

The convection fan can be increased up to 150% of normal operation and will maintain at that setting until changed again by the user.

FU
1

The display should now read “FU” after pressing enter on the “CF” convection fan speed setting; the number represents the current “fuel use” setting. (**note:** this function only available in software v1.33 and higher)

The user has the option to select a second configuration profile to facilitate the use of lower grade fuel, or for installations where additional combustion fan speed is needed. Available values are 1 (default) or 2.

CL
60

After pressing enter on the “FU” fuel use setting, the display should read “CL”. The number represents how often in minutes the cleaning cycle should activate. Change by pressing the “+” or “-” keys. Press “ENTER” to confirm.

The factory setting is every 60 minutes under the FU1 setting, and every 45 minutes under the FU2 setting. The schedule can be set to run anywhere from 0, which is never (not recommended), or any frequency between every 5 and 300 minutes.

The frequency of how often the cleaning cycle should run will vary depending upon pellet quality, heat output settings, availability of outside air, and the natural ventilation of your home.

VU
1.35

The display should now read “VU” after pressing enter on the “CL” cleaning cycle setting; the number represents the current version of the control software on your stove.

The software version of your stove will vary depending upon date of manufacture.

H
13

Press “ENTER” again and the display should read “H” for the current hour in military format. Set the current hour by pressing the “+” or “-” keys. Press “ENTER” to confirm.

M
47

The display should now read “M” for the current time in minutes. Change by pressing the “+” or “-” keys. Press “ENTER” to confirm.

D
3

The display should now read “D” for the current day. 1=Monday, 2=Tuesday, etc. Change by pressing the “+” or “-” keys. Press “ENTER” to confirm.

Press “MENU” to exit programming mode.

At the completion of the above steps, your stove will be programmed to run according to the schedule and settings you established.

You can change your programmed settings at any time by repeating the steps outlined in this manual.

NOTE: Although you may have programmed an operating schedule for your stove, that schedule will not be activated until your stove is put into the Timed or Automatic Mode (TM) as described on page 20.

NOTE: It is not mandatory that you program a schedule for your stove. The option exists for your convenience.

If you choose not to establish an operating schedule, your stove can be operated manually. In manual mode you turn it on/off by pressing the power button, and increase/decrease heat output by pressing the “+” or “-” buttons on the control keypad.

PROGRAMMING THE CONTROL

If you intend to operate your stove manually, set it to the manual mode by pressing the ENTER button until the display no longer reads either “SB” or “TM”.

During start-up, the stove will read “ST” on the first display line, and “21” on the second display line. “ST” stands for start-up and “21” is the remaining start-up time in minutes (the time display will decrease as the start-up progresses).

During the start-up cycle, only the auger and combustion fan operate with the combustion fan gradually increasing in speed. The convection fan will turn on at the end of the start-up cycle.

NOTE: As long as the stove is running, whether in the start-up mode, cleaning cycle, in normal operation, or while operating under the timed mode, you can increase or decrease the heat output level at any time by pressing the “+” or “-” keys.

If the stove needs to be turned off at any time, push the ON/OFF button and the stove will immediately begin the shut-down process. Complete shut-down takes a total of eight minutes. The stove may remain hot for several hours after turning off.

If the stove is running in timed mode when the power button is pushed, the schedule will resume at the next programmed interval.

MAINTENANCE AND CLEANING

Caution: Turn off your stove and allow to cool. Once your stove has properly shut down and cooled, unplug it before performing any cleaning or service.

Caution: Use only a certified ash vacuum to clean your stove. Using a regular home or shop vacuum can result in a fire.

Caution: People with breathing problems should be careful to not inhale ash or dust during the stove cleaning process. If you suffer from any form of lung disease or have difficulty breathing, use of a dust mask is recommended.

Caution: Even after allowing your stove to cool, hot embers may still be present in the firebox. Use caution when you open the door and during the cleaning process. Use care in order to prevent any remaining embers from igniting clothing or objects close to your stove.

To maintain proper operation of your pellet stove, it is important to regularly clean the unit. Failure to regularly clean your stove could lead to decreased performance, increased fuel consumption, and an increased chance of component failure. Component failure caused by lack of proper cleaning is not covered under warranty.

Listed below are recommended cleaning intervals and procedures for cleaning the user serviceable areas of your pellet stove:

Component	Interval
<ul style="list-style-type: none">Heat Exchanger Baffle Tubes (see page 26 for instructions)	once daily and every time fuel is added
<ul style="list-style-type: none">Burn Pot	as needed
<ul style="list-style-type: none">Ash Pan	as needed
<ul style="list-style-type: none">Heat Exchanger area (in combustion chamber behind back cast walls)	monthly or when exchanger rods no longer recess below the top panel

NOTE: The above cleaning intervals are minimum recommendations. More frequent cleaning may be required depending upon factors such as fuel quality and amounts of fuel used, chimney length and complexity, and replacement air conditions in the home.

Tools Required

- Small soft bristled brush
- 6mm hex key wrench that came with your stove
- Ash vacuum (see caution above)
- Flat-tip screwdriver
- Drop cloth or other cover to protect floor
- Flashlight (optional depending upon lighting conditions)
- Rubber gloves (optional)
- Dust mask (optional – see caution above)

Door, Burn Pot and Ash Pan

- Unplug your stove after properly shutting it down and allowing it time to cool.
- Spread a drop cloth or other suitable cover on the floor in front of and around the stove to protect ash and debris from staining floors.
- Open the door and vacuum out as much debris from the burn pot as possible.

MAINTENANCE AND CLEANING

- Clean the door glass by wiping it with a dry paper towel or a dry, wadded up piece of newspaper.
NOTE: Do not use abrasive cleaners to clean the glass. If a glass cleaner is needed, see your stove dealer for a cleaner that is specifically designed for use with wood stoves.
- Clean out any remaining debris from the burn pot by lifting it out, tipping it upside down, and tapping it on the ash pan. If needed, use your flat-tip screwdriver to scrape away and loosen any remaining debris. Continue this process until all remaining ash debris is removed and all of the air holes in the burn pot are clear.
- Vacuum out the ash pan.
- Remove the ash pan and set it aside with the burn pot.
- Vacuum the area underneath where the burn pot sits.
- Using your brush and vacuum, clean the cast iron and gasket areas around the inside perimeter of the door.

Cast Iron Wall Plates

The back wall of the combustion area is made up of two cast iron plates that protect the heat exchanger system from direct flame. If the area behind the cast iron plates is not periodically cleaned, a complete blockage of the air paths can result. Sufficient blockage will cause your stove to perform poorly and could result in a shut down with ERR or ERR/CL showing in the control display.

- Using the 6mm hex key wrench that was provided with your stove, remove the three screws securing the lower cast plate. Once the screws are removed, the plate should pull away from the back of the stove.
- Carefully lift the lower plate out and brush off any ash build-up from the front and back of the plate. When finished, set the plate aside.
- Using the same 6mm hex key wrench, remove the two screws securing the upper cast plate. It's important to support the upper plate while the screws are being removed since this plate is heavy and will fall if not supported.
- Carefully lift the upper plate out and brush off any ash build-up from the front and back of the plate. When finished, set the plate aside.
- Examine the lower plate's gasket material for defect. Minor blemishes on the gasket are acceptable, but replace the gasket if it's broken or if pieces are missing. (gasket material is available through your dealer).

Heat Exchanger Area

When you remove the two cast iron plates from the back of the combustion chamber, the entire heat exchanger system is exposed. You will be able to see the exchanger tubes as well as the scrapers that you activate when you pull up the exchanger cleaning rods on the top of the stove.

- Vacuum the ash from the heat exchanger area, especially the area between the exchanger tubes. The soft brush and flat tipped screwdriver can be used to clean around and between the tubes. Clean out as much ash as possible.
- Carefully brush and clean the uppermost interior of the burn area.
- Carefully brush and clean the grooves on the inside top of the fire box.
- Do a final vacuum of the entire combustion area to remove any additional ash or debris.

Re-Assembly

- Re-attach the top and lower cast iron wall plates (attach the top piece first).
- Re-seat the ash pan and burn pot, making sure that the burn pot is fully seated in place.
- Close the door.
- Plug unit back into wall outlet. Your stove is now ready for normal use.

MAINTENANCE AND CLEANING

Heat Exchanger Baffle Tubes

A primary component of the heat exchanger system is a series of baffle tubes located behind the interior cast iron walls of the combustion chamber. As fuel is consumed, ash builds up on these baffle tubes which reduces the heat transfer capability of your stove. It is recommended that you clean the exchanger baffle tubes no less than one time per day, and every time you add fuel. Regular cleaning of the baffle tubes will ensure that the heat exchanger system is working optimally and that you are getting the greatest amount of heat output possible from your stove.

Cleaning is accomplished by pulling up and pushing down on the two exchanger scraper rods that protrude out of the top of the stove. These rods can be found on the very top of the stove underneath the colored accent panel. There are two holes in the accent panel where the rods recess into. Due to the placement of these two holes, actual removal of the colored accent panel is not necessary for cleaning.

A scraper rod tool was provided with your stove (see image) that is specifically intended for cleaning the exchanger baffle tubes. The two scraper rods described above have a hole at the very top where this tool “hooks” into. Simply hook the tool into each of the two respective rods and pull up/push down two to three times per cleaning.

NOTE: When the stove is hot you may feel resistance when you pull up/push down on the rods. This is normal and occurs as a result of expansion of the stainless steel baffles tubes as they get hot.

NOTE: Any time the stove is on, the scraper rods will be very hot. Do not touch them with your bare hands or you could be burned. Use the oven mitt that was provided with your stove, or other suitable hand protection, before touching any of the metal surfaces of your stove.

Removal or Replacement of Broken Door Glass or Damaged Door Seals

If the door glass becomes damaged in any way, including actual damage to the glass or to one of the gaskets on the door, replacement of the damaged area should occur prior to operating the stove.

While wearing leather gloves, carefully remove any loose pieces of glass from the doorframe. Dispose of all broken glass properly. Return the damaged door to your dealer for replacement or have your dealer do an on-site replacement of the affected area.

In order to maintain proper materials, installation, fit, and any required edge clearances, all repairs or replacement involving door glass, gaskets, or any cushioning devices or components should be performed only by an authorized service technician.



TROUBLESHOOTING

CAUTION: FOR ANY TROUBLESHOOTING PROCEDURE THAT REQUIRES YOU TO OPEN THE DOOR, THE STOVE SHOULD FIRST BE SHUTDOWN AND ALLOWED TO COOL PRIOR TO PROCEEDING.

PROBLEM

The fire is burning with a weak or orange flame, the flames have black tips, pellets are collecting in the burn pot, the window is glazing.

CAUSE:

Inadequate combustion air.

POSSIBLE SOLUTIONS:

- Make sure that the unit has been cleaned. See the Cleaning and Maintenance section of this manual.
- Verify that the burn pot is correctly seated in place.
- Remove any ash or clinker that may be blocking the air inlet openings in the burn pot.
- Change to a better pellet quality.
- Verify that the flue pipe is not blocked with ash. The flue should be cleaned by your dealer at least one time every two tons of fuel, or annually whichever comes first.
- Verify that the air inlet is clean and free of debris. Dust and animal hair can collect on the air sensor and cause the sensor to send false readings to the control system.
- Check door seal by closing a dollar bill in all four sides of the door. When pulling on the bill you should have equal resistance on all four sides. If not, consult your dealer for adjustment.
- Verify that sufficient air flows into the home. This can be verified by opening a window or door. If the flame quality improves, an outside air kit may be necessary.

PROBLEM

The fire goes out and the stove switches itself off automatically.

CAUSE(S):

- Pellet hopper is empty.
- The burn pot is not seated properly.
- The Hi-Temp safety switch was triggered due to excessive temperature.
- The door seal is not tight, is damaged, or the door is not closed properly.
- Poor pellet quality.
- Pellet feed rate too low.
- The Low-Limit switch was triggered due to low temperature.
- Clean-out openings are not closed properly or component seals are not sealed properly.

POSSIBLE SOLUTIONS:

- Fill the hopper with pellets.
- Re-seat the burn pot.
- Perform routine maintenance and cleaning.
- Change the brand of pellets used and only use premium pellets.
- Increase the heat output level.

PROBLEM

Pellets are not feeding

TROUBLESHOOTING

CAUSE(S):

- The hopper is empty
- The auger motor or control board is faulty.
- The auger is blocked (foreign objects, large pieces of wood, etc.).
- The hopper lid is open.

POSSIBLE SOLUTIONS:

- Fill the hopper with pellets.
- Have the dealer check for a auger motor or control board fault and replace if necessary.
- Clean the hopper and auger shaft of foreign debris.
- Close the hopper lid.

PROBLEM

The unit runs for 21 minutes during start-up, then automatically switches off.

CAUSE(S):

-
- The hopper lid is open.
- The hopper recently ran completely out of fuel.
- Exhaust gas has not reached the required temperature.
- Low-Limit temperature switch may be faulty.
- The connection to either the lower or upper limit temperature switches is loose or broken.
- Control board is faulty.

POSSIBLE SOLUTIONS:

- If the stove was completely out of fuel, it may take two complete start-up cycles for the stove to become fully operational. This is due to the fact that it takes approximately 10 to 15 minutes for the auger path to re-load with fuel. During that time, little or no fuel will feed into the burn pot. It is possible at the conclusion of the first complete start-up cycle in this scenario, that the stove will shut down one more time with an error message.
- Have a qualified service technician check the control board and low limit switch, check for loose or incorrect wiring, and replace the low temperature switch and check control.
- Inspect the wiring for proper termination on each component (see block diagram on page 7). Check that there is a good connection between the lines and terminal ends on both the component and control board ends of each wiring loop, and that all components are plugged into the correct location on the motherboard.

PROBLEM

Chimney Fire or a fire in the fuel hopper

- IMMEDIATELY EXIT PREMISES AND CALL 911 FROM A SAFE LOCATION.
- Have your stove and ventilation inspected by a qualified service technician prior to subsequent use.

KEYWORD / ABBREVIATIONS LIST

Key word / Abbreviation	Name	Description
SB	Standby-Mode	Standby mode (fire switched off, but active for triggering via the control)
CF	Convection Fan Combustion Fan	Convection fan speed increase setting over normal or reference to either the combustion or convection fan
FU	Fuel Use Type	Configuration profile to facilitate the use of lower grade fuel, or for installations where additional combustion fan speed is needed. 1 (default) or 2
ON	On-Mode	Manual operation
TM	Time-Mode	Automatic Operation used in conjunction with an established schedule
MO, TU, WE, TH, FR, SA, SU	Weekdays	Monday to Sunday
S1, S2 E1, E2	Start 1, Start 2 End 1, End 2	Heating start times, heating end times for automatic (TM) mode
PS	Power-Start	Output value from the beginning of heating time in TM-Mode
PE	Power-End	Output value from the end of heating in TM-Mode
CL	Clean	Cleaning mode
VU	Version	Pellet control software version (varies depending upon purchase date)
H, M, D	Hour, Minute, Day	Hour, minute, day memory for internal clock (in military format)
ST	Start	Pre-heating / startup program run
EX	Exit	Exit program running
MENU	Menu Button	Navigation in and to the different sub-menu levels.
ENTER	Enter Button	Navigation in the main menus (SB, ON, TM) and confirming user entry
+/-	Plus & Minus Buttons	Increases and decreases user values
ON/OFF	ON / OFF Button	Turns the system on and off

USER NOTES

This page is provided for your use to record your Time Mode (TM) schedule and other operating notes or observations.

My Heating Schedule

<u>Day</u>	<u>1st Heating Cycle</u>		<u>2nd Heating Cycle</u>	
	<u>(S1)</u>	<u>(E1)</u>	<u>(S2)</u>	<u>(E2)</u>
Monday	Start _____	End _____	Start _____	End _____
Tuesday	Start _____	End _____	Start _____	End _____
Wednesday	Start _____	End _____	Start _____	End _____
Thursday	Start _____	End _____	Start _____	End _____
Friday	Start _____	End _____	Start _____	End _____
Saturday	Start _____	End _____	Start _____	End _____
Sunday	Start _____	End _____	Start _____	End _____

Power Setting (PS) _____ (output to use during above schedule heating times)

Power End (PE) _____ (output to use between above scheduled heating times)

***Convection Fan (CF)** _____ (increase over normal – up to 150%)
* this function only available in software v1.33 and higher

***Fuel Type (FU)** _____ (use FU2 for altitude above 2000ft and/or direct vent installations)
* this function only available in software v1.33 and higher

Cleaning Cycle (CL) _____ (cleaning cycle frequency – FU1 default is 60, FU2 default is 45)

Software Version (VU) _____ (minimum US version is 1.28)

Other Notes

WARRANTY

PLEASE TAKE NOTICE THAT THIS WARRANTY APPLIES ONLY TO STOVES PURCHASED FROM LUCKY DISTRIBUTING, INC. OR ONE OF ITS AUTHORIZED DEALERS. LUCKY DISTRIBUTING INC. MAKES NO WARRANTY IF YOU PURCHASED YOUR STOVE FROM A DEALER OR SELLER NOT AUTHORIZED BY LUCKY DISTRIBUTING, INC.

There is expressly no warranty on the following components:

- Glass
- Paint
- Metal Plating
- Gasket Material
- Burn Pots
- Ceramics
- Natural Stone

WARRANTY LIMITATIONS:

MANUFACTURER, DISTRIBUTOR AND SUPPLIER MAKE NO OTHER WARRANTIES, EXPRESS OR IMPLIED, INCLUDING ANY WARRANTY OF MERCHANTABILITY OR WARRANTY OF FITNESS FOR A PARTICULAR PURPOSE.

LIMITATION OF LIABILITY:

MANUFACTURER, DISTRIBUTOR AND SUPPLIER SHALL NOT BE LIABLE FOR ANY INCIDENTAL OR CONSEQUENTIAL DAMAGES TO PROPERTY OR PERSONS ARISING FROM OR RELATED TO USE OF THIS PRODUCT. USER'S SOLE AND EXCLUSIVE REMEDY FOR ANY NONCONFORMITY IN THE PRODUCT OR ANY CLAIM RELATED TO THE USE OF THE PRODUCT SHALL BE, AT MANUFACTURER'S OPTION, REPAIR OR REPLACEMENT OF THE PRODUCT, OR RETURN OF THE PRODUCT FOR THE PURCHASE PRICE PAID FOR THE PRODUCT.

The manufacturer provides a five year limited warranty on all steel parts (**except the burn pot**), and a **two year** limited warranty on all electrical components. These warranties commence on the date of the original purchase.

An optional five year extended warranty on all electrical components is available.

This warranty covers defects in materials and workmanship in covered components,

provided the product has been installed and operated strictly in accordance with the Manufacturer's printed instructions. This warranty does not cover damage or breakage caused by improper handling, misuse, or unauthorized modification.

Without limiting the foregoing, the use of fuel other than wood pellets, or improper installation voids all warranties.

**RIKA / Lucky Distributing, Inc.
8111 NE Columbia Blvd.
Portland, OR 97218**

ALL WARRANTY CLAIMS MUST BE SUBMITTED ON A VALID CLAIM FORM AND MUST INCLUDE:

1. Name, address, and telephone number of the purchaser.
2. Name, address, and telephone number of the seller, date and proof of purchase.
3. Name, address, and telephone number of installer, and date of installation.
4. Serial number of the stove.
5. Nature of defect, malfunction, or complaint.

Arrangements will be made for inspection. If the inspection indicates that the failure was due to defective material or workmanship in covered components and that the other terms and conditions of this warranty have been complied with, the Manufacturer's sole duty and liability under this warranty shall be limited to the Manufacturer's replacement or repair, at the Manufacturer's option, of the defective unit or part. The purchaser assumes all costs of shipping to and from the Manufacturer or his agent and shall be responsible for all losses incurred during shipment. Removal and reinstallation costs are not covered under this warranty.

Neither the Manufacturer nor the supplier to the purchaser accept responsibility, legal or otherwise, for incidental or consequential damage to property or persons resulting from the use of this product. Any warranty implied by law, including, but not limited to, implied warranties of merchantability or fitness, shall be limited to one year from the date of the original purchase. Whether a claim is

made against the Manufacturer based on a breach of this warranty or any other type of warranty, expressed or implied by law, the Manufacturer shall in no event be liable for any special, indirect, consequential, or other damages of any nature whatsoever in excess of the original purchase price of this product. All warranties by the Manufacturer are set forth herein, and no claim shall be made against the Manufacturer based on any oral warranty or representation.

Some states do not allow the exclusion or limitation of consequential damages or limitations of implied warranties, so the limitations or exclusions set forth in this warranty may not apply to you.

WARNING

Changes to the design characteristics or operating parts are not authorized by the Manufacturer and will void any and all warranties. Such changes may create hazardous conditions which can endanger the user and/or his property.

This warranty gives you specific legal rights, and you may have other rights which vary from state to state.



8111 NE Columbia Blvd.
Portland, OR 97218



NO POSTAGE
NECESSARY
IF MAILED
IN THE
UNITED STATES



BUSINESS REPLY MAIL

FIRST-CLASS MAIL PERMIT NO 911 PORTLAND OR

POSTAGE WILL BE PAID BY ADDRESSEE

AUSTROFLAMM / RIKA
8111 NE Columbia Blvd.
Portland, OR 97218-9901



This warranty registration guarantees your coverage.

To register your new RIKA stove,
completely fill out the card below:
Fax it: 1-800-777-7069 or
Mail it: Postage is already paid.

Warranty Proof: Your registration
serves as proof of purchase for your
warranty coverage. Please make sure
the card is completed in order to
guarantee coverage.



AUSTROFLAMM/RIKA Customer Service: 1-800-777-5594 FAX: 1-800-777-7069

MR. MS. MRS.

FIRST NAME LAST NAME

Grid for entering first and last names.

COMPANY NAME

Grid for entering company name.

ADDRESS

Grid for entering address.

CITY STATE ZIP CODE

Grid for entering city, state, and zip code.

PHONE E MAIL

Grid for entering phone and email.

DEALER NAME

Grid for entering dealer name.

DEALER PHONE FAX

Grid for entering dealer phone and fax.

DEALER CITY STATE ZIP CODE

Grid for entering dealer city, state, and zip code.

DATE OF PURCHASE MODEL

Grid for entering date of purchase and model.

Serial Number Information (required)

Pellet Stove Serial #

Grid for entering pellet stove serial number.

Pellet Stove Serial # Pellet Stove Serial #

Grid for entering two pellet stove serial numbers.

Wood Stove Serial # Wood Stove Serial #

Grid for entering two wood stove serial numbers.

Wood Stove Serial # Wood Stove Serial #

Grid for entering two wood stove serial numbers.

WHERE DID YOU HEAR ABOUT AUSTROFLAMM/RIKA?

- Friend
- Dealer Recommendation
- Magazine (please specify) _____
- Other (please specify) _____
- Received information from DLRS



Warranty Registration



