



IPX4



WOOD PELLET GRILL AS660

IMPORTANT, READ CAREFULLY,
RETAIN FOR FUTURE REFERENCE.
MANUAL MUST BE READ
BEFORE OPERATING!

AS660

82-260°C / 180-500°F

ASSEMBLY AND OPERATION
ASSEMBLAGE ET FONCTIONNEMENT
MONTAJE Y OPERACIÓN



WARNING: Please read the entire manual before installation and use of this electric, pellet fuel-burning appliance. Failure to follow these instructions could result in property damage, bodily injury or even death. Contact local building or fire officials about restrictions and installation inspection requirements in your area.

RECIPES INCLUDED

FOR OUTDOOR AND HOUSEHOLD USE ONLY. NOT FOR COMMERCIAL USE. RÉSERVÉ À L'USAGE EXTÉRIEUR ET RÉSIDENTIEL UNIQUEMENT. NON DESTINÉ À UN USAGE COMMERCIAL. SOLO PARA USO EN EXTERIORES Y EN EL HOGAR. NO ES PARA USO COMERCIAL.

SAFETY INFORMATION

MAJOR CAUSES OF APPLIANCE FIRES ARE A RESULT OF POOR MAINTENANCE AND A FAILURE TO MAINTAIN REQUIRED CLEARANCE TO COMBUSTIBLE MATERIALS. IT IS OF UTMOST IMPORTANCE THAT THIS PRODUCT BE USED ONLY IN ACCORDANCE TO THE FOLLOWING INSTRUCTIONS.

Please read and understand this entire manual before attempting to assemble, operate or install the product. This will ensure you receive the most enjoyable and trouble-free operation of your new wood pellet grill. We also advise you retain this manual for future reference.

DANGERS AND WARNINGS

You must contact your local home association, building or fire officials, or authority having jurisdiction, to obtain the necessary permits, mission or information on any installation restrictions, such as any grill being installed on a combustible surface, inspection requirements or even ability to use, in your area.

1. A minimum clearance of 915mm (36 inches) from combustible constructions to the sides of the grill, and 915mm (36 inches) from the back of the grill to combustible constructions must be maintained. **Do not install appliance on combustible floors, or floors protected with combustible surfaces unless proper permits and permissions are obtained by authorities having jurisdiction.** Do not use this appliance indoors, in an enclosed or unventilated area, inside homes, vehicles, tents, garages. This wood pellet appliance must not be placed under overhead combustible ceiling or overhang. Keep your grill in an area clear and free from combustible materials, gasoline and other flammable vapors and liquids.

Should a grease fire occur, turn the grill OFF and leave the lid closed until the fire is out. Unplug the power cord. Do not throw water on the unit. Do not try to smother the fire. Use of an all-class (class ABC) approved fire extinguisher is valuable to keep on site. If an uncontrolled fire does occur, call the Fire Department.

2. Keep electrical supply cords and the fuel away from heated surfaces. Do not use your grill in the rain or around any water source.
3. After a period of storage, or non-use, check the burn grate for obstructions, the hopper for foreign objects, and any air blockage around the fan intake or chimney. Clean before use. Regular care and maintenance is required to prolong the lifespan of your unit. **If the grill is stored outside during the rainy season or seasons of high humidity, care should be taken to insure that water does not get into the hopper.** When wet or exposed to high humidity, wood pellets will expand greatly, decompose, and may jam the feed system. Always disconnect the power, before performing

Do not transport your grill while in use or while the grill is hot. Ensure the fire is completely out and that the grill is completely cool to the touch before moving.

any service or maintenance.

4. It is recommended to use heat-resistant barbecue mitts or gloves when operating the grill. Do not use accessories not specified for use with this appliance. Do not put a barbecue cover or anything flammable in the storage space area under the barbecue.
5. To prevent fingers, clothing or other objects from coming in contact with the auger feed system, the appliance is equipped with a metal safety screen, mounted to the interior of the hopper. This screen must not be removed unless directed by Customer Service or an authorized dealer.

This appliance is not recommended for children, persons with reduced physical, sensory or mental capabilities, or lack of experience and knowledge, unless they are under direct supervision or instruction by a person responsible for their safety.

6. Parts of the barbecue may be very hot, and serious injury may occur. Keep young children and pets away while in use.
7. Do not enlarge igniter holes or burn pots. Failure to follow this warning could lead to a fire hazard and bodily harm and will void your warranty.
8. Product may have sharp edges or points. Contact may result in injury. Handle with care.
9. If the supply cord is damaged, it must be replaced by manufacturer, its service agent or similarly qualified persons in order to avoid a hazard.
10. Children should be supervised to ensure that they do not play with the appliance.

DISPOSAL OF ASHES

Ashes should be placed in a metal container with a tight-fitting lid. The closed container of ashes should be placed on a non-combustible floor or on the ground, well away from all combustible materials, pending final disposal. When ashes are disposed by burial in soil, or otherwise locally dispersed, they should be retained in a closed container until all cinders have thoroughly cooled.

WOOD PELLET FUEL

This pellet cooking appliance is designed and approved for pelletized, all natural, no blend pure wood. Any other type of fuel burned in this appliance will void the warranty and safety listing. You must only use all natural wood pellets, designed for burning in pellet barbecue grills. Do not use fuel with additives.

**Do not use spirit, petrol, gasoline, lighter-fluid or kerosene for lighting or refreshing a fire in your grill.
Keep all such liquids well away from the appliance when in use.**

At the time of printing, there is no industry standard for barbecue wood pellets, although most pellet mills use the same standards to make wood pellets for domestic use. Further information, can be found at www.pelletheat.org or the *Pellet Fuel Institute*.

Contact your local dealer on the quality of pellets in your area, and for information on brand quality. As there is no control over the quality of pellets used, moisture affected pellets, we assume no responsibility to damage caused by poor quality of fuel.

CREOSOTE

Creosote, or soot, is a tar-like substance. When burning, it produces black smoke with a residue which is also black in color. Soot or creosote is formed when the appliance is operated incorrectly, such as: blockage of the combustion fan, failure to clean and maintain the burn area, or poor air-to-fuel combustion.

It is dangerous to operate this appliance should the flame become dark, sooty, or if the burn pot is overfilled with pellets. When ignited, this creosote makes an extremely hot and uncontrolled fire, similar to a grease fire. Should this happen, turn the unit OFF, let it cool completely, then inspect for maintenance and cleaning. It commonly accumulates along exhaust areas.

If creosote has formed within the unit; allow the unit to warm up at a low temperature, turn off the appliance, then wipe away any formation with a hand towel. Similar to tar, it is much easier to clean when warm, as it becomes liquid.

CARBON MONOXIDE (“the silent killer”)

Carbon monoxide is a colorless, odorless, tasteless gas produced by burning gas, wood, propane, charcoal or other fuel. Carbon monoxide reduces the blood’s ability to carry oxygen. Low blood oxygen levels can result in headaches, dizziness, weakness, nausea, vomiting, sleepiness, confusion, loss of consciousness or death. Follow these guidelines to prevent this colorless, odorless gas from poisoning you, your family, or others:

- See a doctor if you or others develop cold or flu-like symptoms while cooking or in the vicinity of the appliance. Carbon monoxide poisoning, which can easily be mistaken for a cold or flu, is often detected too late.
- Alcohol consumption and drug use increase the effects of carbon monoxide poisoning.

Carbon monoxide is especially toxic to mother and child during pregnancy, infants, the elderly, smokers, and people with blood or circulatory system problems, such as anemia, or heart disease.

SAFETY LISTING

CAS/UL 60335-1 & IEC 60335-2-102





COPYRIGHT NOTICE

Copyright 2019. All right reserved. No part of this manual may be copied, transmitted, transcribed, stored in a retrieval system, in any form or by any means without expressed written permission of,

Asmoke USA LLC

72 Three Rivers Dr Newark, DE 19702

support@asmokegrill.com

www.asmokegrill.com

Customer Service

Monday through Sunday, 9am - 5pm PST (EN)

Toll-Free: 1-877-255-2499

TABLE OF CONTENTS

Safety Information.....	1	Care & Maintenance.....	16
Parts & Specs.....	5	Using Wood Pellet Fuel.....	18
Assembly Preparation.....	6	Cooking Guidelines.....	19
Assembly Instructions		How to Use Meat Probe.....	20
Mounting The Wheels ToThe Legs.....	6	Tips & Techniques.....	21
Mounting The Wheels To The Cart.....	7	Troubleshooting.....	22
Installing The Cart ToThe Barrel.....	7	Electrical Wire Diagram.....	24
Mounting The Hopper To The Main Barrel.....	8	Replacement Parts	
Installing The Lid Handle.....	8	Grill Replacement Parts.....	25
Securing The Chimney.....	9	Hopper Replacement Parts.....	26
Installing The Cooking Components (1).....	9	Exceptions.....	27
Installing The Cooking Components (2).....	9	Ordering Replacement Parts.....	27
Installing The Storage Tray.....	10	Contact Customer Service.....	27
Placing The Grease Bucket.....	10	Warranty Service.....	27
Connecting To A Power Source.....	10	Recipes.....	28
Operating Instructions		5-Year Warranty	
Grill Environment.....	11	Conditions.....	30
Grill Temperature Ranges.....	12		
Understanding The Control Board.....	13		
Understanding The Probes.....	14		
Understanding The "P" Setting.....	14		
Hopper Priming Procedure.....	14		
First Use – Grill Burn-Off.....	15		
Automatic Start-Up Procedure.....	15		
Manual Start-Up Procedure.....	16		
Shutting Off Your Smoker.....	16		

PARTS & SPECS

Part#	Description
1	Lid Handle
2	Lid Handle Bezel (x2)
3	Main Lid
4	Hopper Assembly
5	Chimney Cap
6	Chimney
7	Chimney Gasket
8	Serving Tray Handle
9	Serving Tray
10	Serving Tray Bracket
11	Pin
12	Grease Bucket
13	Porcelain-Coated Steel Upper Cooking Rack
14	Porcelain-Coated Cast-Iron Cooking Grids (x2)
15	Flame Broiler Slider
16	Flame Broiler Main Plate
17	Short Support Leg (x2)
18	Long Support Leg (x2)
19	Wheel Axle Pin (x2)
20	Wheel (x2)
21	Wheel Cotter Pin (x2)
22	Wheel Axle Washer (x2)
23	Bottom Shelf
24	Locking Caster Wheel (x2)
25	Hopper Handle
26	Main Barrel
27	Hopper Housing Gasket
28	Hexagon Screwdriver(x1)
29	Meat Probe (x2)

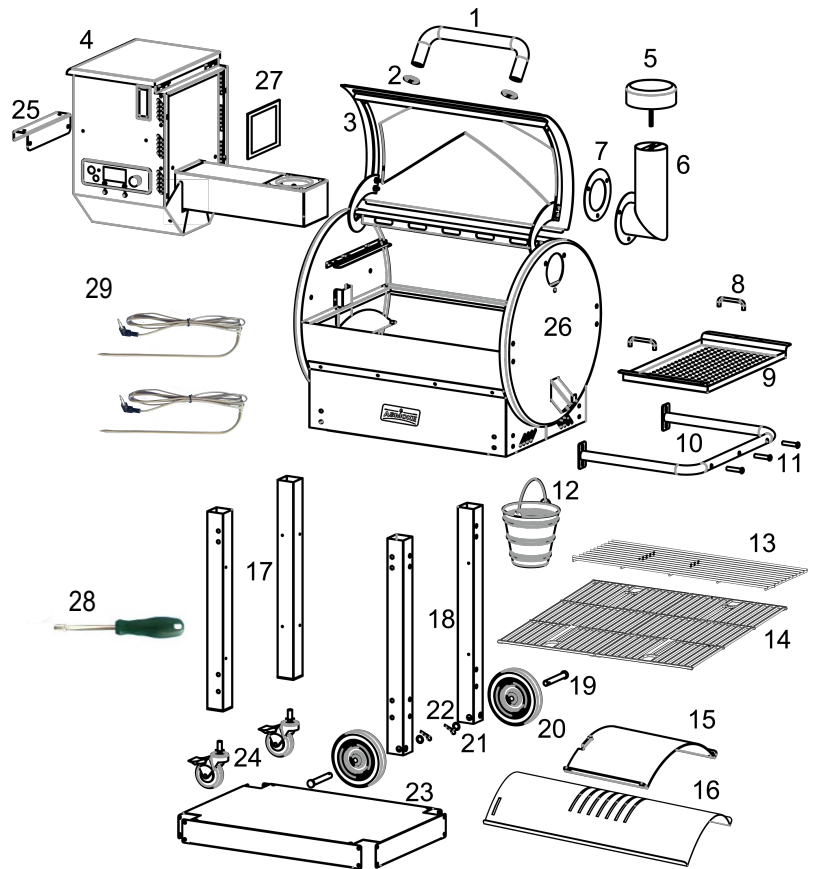

- | | | |
|----------|--|------------------------|
| A | | Wheel Axle Washer (x2) |
| B | | Wheel Axle Pin (x2) |
| C | | Wheel Cotter Pin (x2) |
| D | | Screw (x34) |
| E | | Washer (x40) |
| F | | Locking Washer (x40) |
| G | | Igniter Screw (x2) |
| H | | Hopper Screw (x6) |
| I | | Lid Handle Screw (x2) |

NOTE: Due to ongoing product development, parts are subject to change without notice. Contact Customer Service if parts are missing when assembling the unit.

AS - ELECTRIC REQUIREMENTS

110V~120V, 3.1AMP, 60Hz, 250W, 3-PRONG GROUNDED PLUG

MODEL	UNIT ASSEMBLED (WxHxD)	UNIT WEIGHT	COOKING AREA	TEMP. RANGE	DIGITAL FEATURES
AS AS660	1,330mmx830mmx1,300mm / 52.4" x 32.7" x 51.2"	Total: 64Kg/141.1 lb	Main - 3,120 cm ² / 484 sq. in. Upper Rack - 1,390 cm ² / 215 sq. in. in. TOTAL - 4,510 cm² / 700 sq. in.	82-260°C / 180-500°F	Ten temperature presets, start-up cycle, electric igniter

ASSEMBLY PREPARATION

Parts are located throughout the shipping carton, including underneath the grill. Inspect the grill, parts, and hardware blister pack after removing from the protective shipping carton. Discard all packaging materials from inside and outside of the grill before assembly, then review and inspect all parts by referencing the parts list. If any part is missing or damaged, do not attempt to assemble. Shipping damage is not covered under warranty. Contact your dealer or ASMOKE Customer Service for parts: Monday through Sunday, 9am - 5pm PST (EN).

support@asmokegrill.com | Toll-Free: 1-877-255-2499

IMPORTANT: To ease installation, using two people is helpful (but not necessary) when assembling this unit.

Tools required for assembly: screwdriver and level. *Tools not included.*

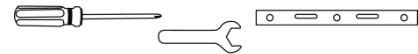

ASSEMBLY INSTRUCTIONS

IMPORTANT: It is advised to read each step entirely before starting assembly on instructions. Do not tighten screws completely until all screws for that step have been installed. Hardware combination involving a locking washer and washer should be installed with the locking washer closest to the head of the screw.

1. MOUNTING THE WHEELS TO THE LEGS

Parts Required:

- 1 x Bottom Shelf (#23)
- 2 x Short Support Leg (#17)
- 2 x Long Support Leg (#18)
- 16 x Screw (#A)
- 16 x Washer (#C)
- 16 X Locking Washer(#3)

Installation:

- Place a piece of cardboard on the floor to prevent scratching the unit and parts, To ease installation, turn the bottom shelf upside-down (flat side down). Prepare the four support legs for installation, separating the two short support legs from the two long support legs.
- Attach one short support leg by carefully sliding it into a corner of the bottom shelf; then secure using four washers, locking washers and screws. Ensure the threaded hole on the bottom is on the end of the support leg closest to the bottom shelf. Repeat installation for the other short support leg, installing it to the corner along the same short side of the bottom shelf.
- Continue cart installation by securing the one long support leg to the other side of the bottom shelf. Ensure that the wheel axle hole is on the end of the support leg closest to the bottom shelf. Repeat installation for the other long support leg on the last corner.

NOTE: Fasten screws of the bottom shelf only half-way all screws have been installed. Once all screws are installed, then tighten securely into the support legs.

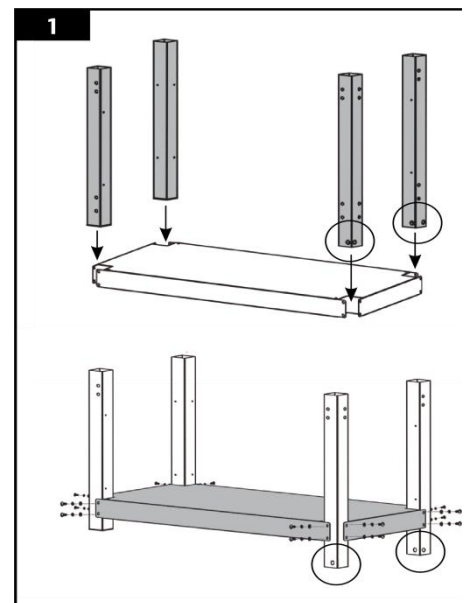

2. MOUNTING THE WHEELS TO THE CART

Parts Required:

- 2 x Locking Caster Wheel (#24)
- 2 x Wheel (#20)
- 2 x Wheel Axle Pin (#B)
- 2 X Wheel Axle Washer (#A)
- 2 x Wheel Cotter Pin (#C)

Installation:

- Attach the wheel to the long support leg by inserting the wheel axle pin through the wheel, long support leg, wheel axle washes then secure using the wheel cotter pin. Note illustration 2A. Repeat installation for the other wheel.
- Insert each locking caster wheel into the bottom of each short support leg by hand-tightening into the hole. Ensure the locking caster wheel is inserted completely.
- Once all wheels are mounted, the two locking caster wheels should be on the same side, and the two support legs with the wheels should be on the opposing end. Note illustration 2B.

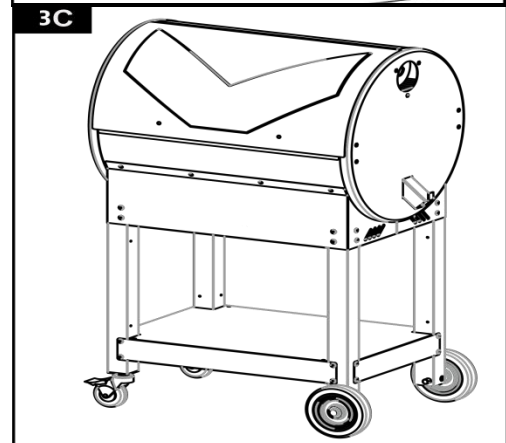
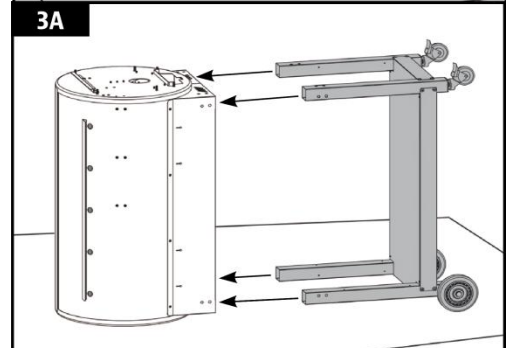
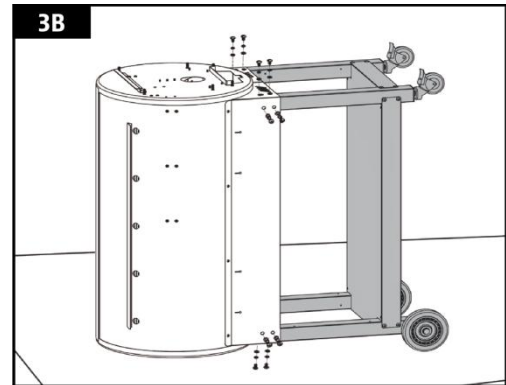
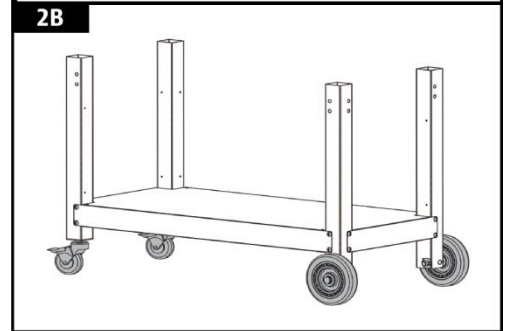
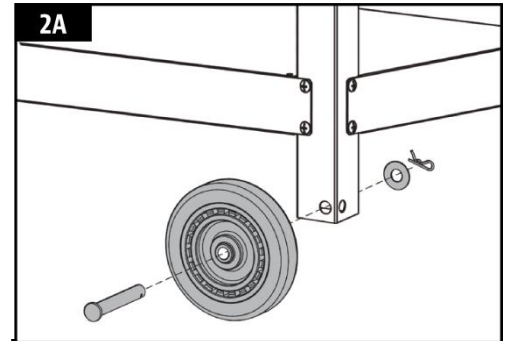

3. INSTALLING THE CART TO THE BARREL

Parts Required:

- 1 x Main Barrel (#26)
- 16 x Screw (#D)
- 16 x Locking Washer (#F)
- 16 x Washer (#E)

Installation:

- Lay the main barrel on its side, hopper end pointed upward, on the cardboard. Ensure the support legs with the locking caster wheels are pointed upward, on the same side as the hopper. Note illustration 3A.
- Insert the assembled cart into the main barrel brace, and secure each leg to the brace using four washers, locking washers and screws. Repeat same installation for the other three support legs. Note illustration 3B. To ease installation of the final side, carefully turn the grill to lie on its back to secure the last four screws to the main barrel brace.
- Once the cart is secured to the main barrel, position the grill back onto its side (hopper end pointed upward), then carefully lift the grill up to an upright position with the wheels on the bottom.

IMPORTANT: Lock caster wheels before lifting grill to upright position.

NOTE If two persons are assembling the unit, the main barrel may be lifted onto the upright cart to secure. Lift carefully to avoid injury.

4. MOUNTING THE HOPPER TO THE MAIN BARREL

Parts Required:

- 1 x The Feeding Box (#4)
- 1 x Heat Insulated Pad (#27)
- 4 x Hexagonal Fixed Bolts (Pre-assembled)

Installation:

- Remove the four 1/4-20 hexagonal fixed bolts that were pre-assembled on the feeding box, which is shown in Figure 4A.
- Make sure that heat insulate pad under feeder is not missing.
- Insert the sub-assembly of the feeding box into the principal part of cylinder, which is shown in Figure 4B.
- Connect the interface of thermoresponsive probe in the control panel on the sub-assembly of the feeding box to the probe of measuring temperature on the principal part of cylinder, and ensuring that the socket is firmly connected.
- Insert the sub-assembly of the feeding box completely into the cylinder, using pre-assembled bolts dismantled from the inner side of the cylinder to fix the sub-assembly of the feeding box and the side panel of cylinder, which is shown Figure 4C.

Note:

It is necessary that make sure the pad of insulating hot under feeder is not lost before fixing the sub-assembly of the feeding box. It is necessary that make sure the probe of measuring temperature has been connected firmly. It is necessary to avoid the harm caused by the automatic drop of lid on the cylinder when fixing the bolt.

5. INSTALLING THE LID HANDLE

Parts Required:

- 1 x Lid Handle (#1)
- 2 x Lid Handle Bezel (#2)
- 2 x Hexagonal Fixed Bolts (Pre-assembled)

Installation:

- Dismantle the pre-assembled hexagonal fixed box from the handle on the lid. Insert a screw from the inside of the cylinder's lid to expose it on the outside. Add a ornament of handle on the lid to the screw and manually tighten the screw from the inside.
- Install the another part of handle on the lid by the same way.

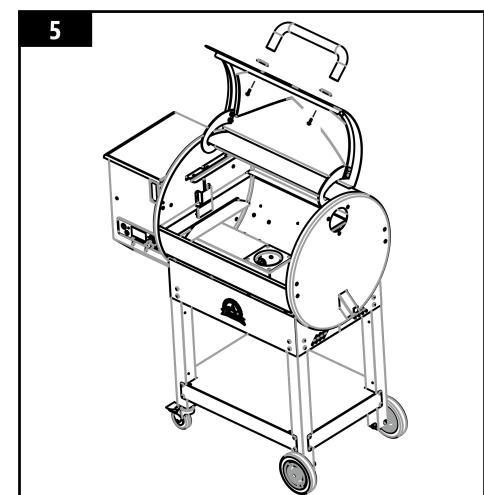
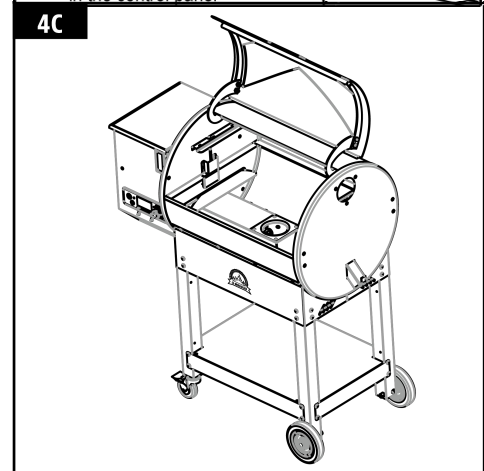
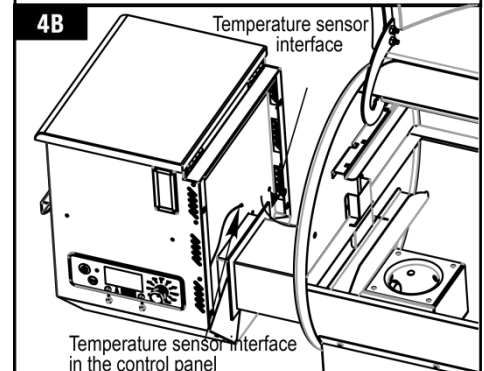
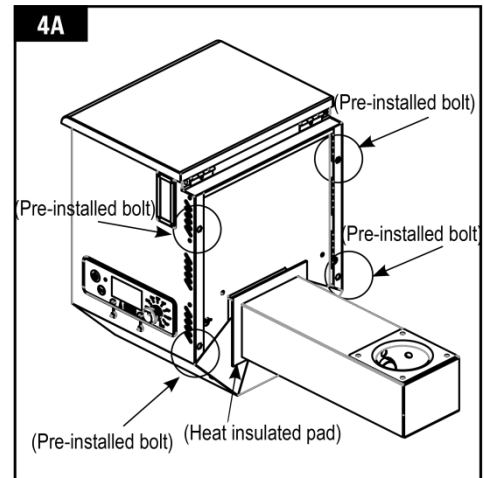

6. SECURING THE CHIMNEY

Parts Required:

- 1 x Chimney Cap(#5)
- 1 x Chimney (#6)
- 1 x Chimney Gasket (#7)
- 3 x Screw (Pre-Installed)

Installation:

- Dismantle three screws pre-installed on the right side of the principal part.
- Locate the chimney hole on the side of the principal part of cylinder. Fix the chimney and chimney gasket on the side panel with three screws, locked gaskets and gaskets from the outside. Fasten the screw to the pre-mounted nut on the inner side of the cylinder.
- Make sure the air can pass through the chimney cap.

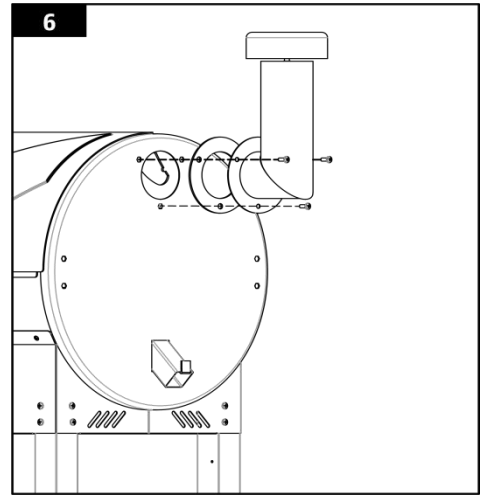

7. INSTALLING THE COOKING COMPONENTS (1)

Parts Required:

- 1 x Flame Broiler Main Plate (#16)
- 1 x Flame Broiler Slider (#15)

Installation:

- Remove the packaging on the flame broiler main plate and the flame broiler slider.
- Place the flame broiler main plate on the bracket inside the main barrel. The bracket on the side of the main barrel into the notch on the left side of the flame broiler main plate.
- Place the flame broiler slider as shown in Figure 7B above the flame broiler main plate, the flame broiler slider can slide left and right as shown in this figure.

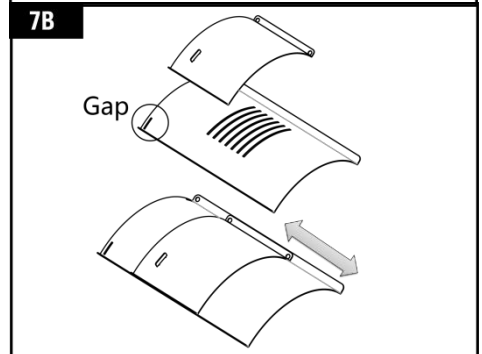
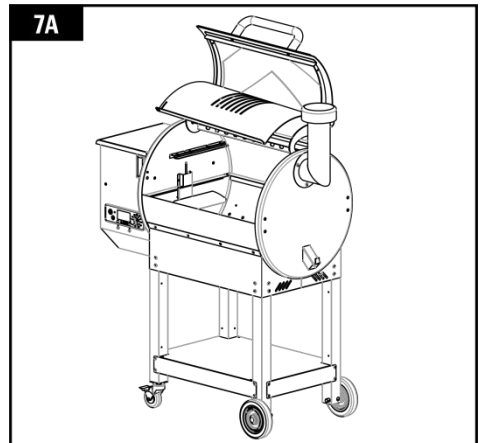

8. INSTALLING THE COOKING COMPONENTS (2)

Parts Required:

- 2 x Cooking Grids (#2)
- 1 x Upper Cooking Rack (#1)

Installation:

- Remove the packaging material with the upper cooking rack and cooking grids.
- Place the cooking grids, side-by-side, on the grid ledge inside the main grill. Place the upper cooking rack on the upper ledge inside the main grill. The cooking rack will lock into place.
- Note: To maintain the searing and grilling performance of your cooking grids, regular care and maintenance is required.
- The unit is now completely assembled. Note illustration 10.



9. INSTALLING THE STORAGE TRAY

Parts Required:

- 2 x Serving Tray Handle (8#)
- 1 x Serving Tray (#9)
- 1 x Serving Tray Bracket(#10)
- 3 x Pin(#11)

Installation:

- Dismantle pre-assembled screws and gaskets for installing brackets from the side panel of cylinder.
- Fix the bracket of storage tray to the side panel of cylinder, using four sets of screw sub-assemblies unloaded from the side panel of cylinder.
- Dismantle the pre-assembled screws on the handle of storage tray, and install the handle to the storage tray. Place the storage tray on the bracket.
- Dismantle the pre-assembled screws, gaskets from the towel pin, and fix the towel pin to the bracket of storage tray.

NOTE:

Avoid using the bracket of storage tray to move or lift the grill. The weight of grill will lead to the bracket to bend or break, which is not covered by warranty.

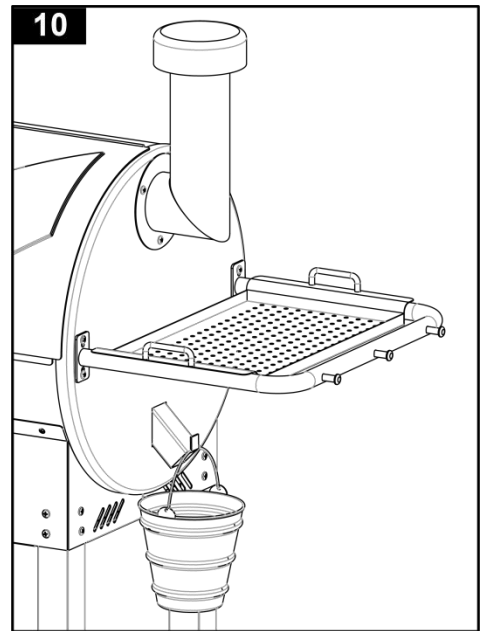
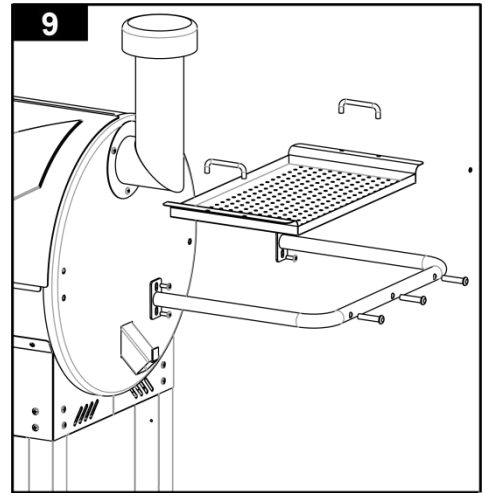

10. PLACING THE GREASE BUCKET

Parts Required:

- 1 x Grease Bucket (#12)

Installation:

- Place the grease bucket on the spout hook on the end of the main barrel. Ensure it is level to avoid grease spills.
- The unit is now completely assembled.

NOTE: Simply insert a disposable foil bucket liner into your grill's grease bucket, then toss when full. It's ready to catch your grill's grease and oil run off for easy clean up and maintenance.

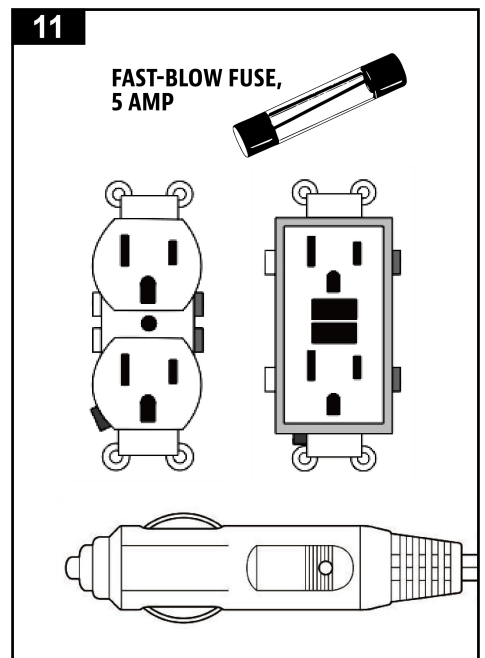

11. CONNECTING TO A POWER SOURCE

NOTE: Before plugging your ASMOKE into any electrical outlet, ensure the temperature dial is in the OFF position.

- **STANDARD OUTLET**
 - This appliance requires 110 volt, 60hz, 255w, 5 amp service. It must be a 3-prong grounded plug. Ensure grounded end is not broken off before use. The control uses a 5 amp, 120 volt, fast-blow fuse to protect the board from the igniter.
- **GFCI OUTLETS**
 - This appliance will work on most GFCI outlets, with a recommended size of 15 amp service. If your GFCI outlet is highly sensitive to power surges, it will likely trip during the start-up phase of operation. During the start-up phase, the

- igniter draws 200-700 watts of electricity which can be too much power for a GFCI outlet to handle. Each time it trips, it increases in sensitivity. If the GFCI keeps tripping, replace the outlet or change to a non-GFCI outlet.
- **ON THE ROAD**
- Disconnect the igniter from the main wiring harness. Use the manual COLD WEATHER COOKING
- start-up procedure. A ASMOKE unit can operate using a 12 volt, 100 watt inverter plugged into your automobile outlet. To use the automatic igniter, it is recommended to use a minimum of a 1000 watt inverter.

IMPORTANT: Disconnect unit from power source when not in use.

OPERATING INSTRUCTIONS

With today's lifestyle of striving to eat healthy and nutritious foods, one factor to consider is the importance of reducing fat intake. One of the best ways to cut down on fat in your diet is to use a low fat method of cooking, such as grilling. As a pellet grill uses natural wood pellets, the savory wood flavor is cooked into the meats, reducing the need for high sugar content sauces. Throughout this manual, you will notice the emphasis on grilling food slowly at LOW or MEDIUM temperature settings.

GRILL ENVIRONMENT

1. WHERE TO SET-UP THE GRILL

With all outdoor appliances, outside weather conditions play a big part in the performance of your grill and the cooking time needed to perfect your meals. All ASMOKE units should keep a minimum clearance of 915mm (36 inches) from combustible constructions, and this clearance must be maintained while the grill is operational. This appliance must not be placed under overhead combustible ceiling or overhang. Keep your grill in an area clear from combustible materials, gasoline and other flammable vapors and liquids.

As it becomes cooler outside, that does not mean that grilling season is over! The crisp cool air and heavenly aroma of smoked foods will help cure your winter blues.

Follow these suggestions on how to enjoy your grill throughout the cooler months:

- If smoking at low temperatures fails, increase the temperature slightly to achieve the same results.
- Organize – Get everything you require ready in the kitchen before you head outdoors. During the winter, move your grill to an area that is out of the wind and direct cold. Check local bylaws regarding the proximity of your grill in relation to your home and/or other structures. Put everything you need on a tray, bundle up tight, and get it done!
- To help keep track of the outside temperature, place an outdoor thermometer close to your cooking area. Keep a log or history of what you cooked, the outdoor temperature, and the cooking time. This will help later down the road to help you determine what to cook and how long it will take.
- In very cold weather, increase your preheating time by at least 20 minutes.
- Avoid lifting the lid any more than necessary. Cold gusts of wind can completely cool your grill temperature. Be flexible with your serving time; add extra cooking time each time you open the lid.
- Have a heated platter or a dish cover ready to keep your food warm while making the trip back inside.
- Ideal foods for winter cooking are those that require little attention, such as roasts, whole chickens, ribs, and turkey. Make your meal preparation even easier by adding simple items such as vegetables and potatoes.

2. HOT WEATHER COOKING

As it becomes warmer outdoors, the cooking time will decrease.

Follow these few suggestions on how to enjoy your grill throughout the hot months:

- Adjust your cooking temperatures downward. This helps to avoid unwanted flare-ups.
- Use a meat thermometer to determine the internal temperature of your foods. This helps in preventing your meat from over cooking and drying out.
- Even in hot weather it is still better to cook with the lid of your grill down.
- You can keep foods hot by wrapping them in foil, and placing them in an insulated cooler. Stuff crumpled up newspaper around the foil and this will keep food hot for 3 to 4 hours.

GRILL TEMPERATURE RANGES

Temperature readouts on the control board may not exactly match the thermometer. All temperatures listed below are approximate and are affected by the following factors: outside ambient temperature, the amount and direction of wind, the quality of pellet fuel being used, the lid being opened, and the quantity of food being cooked.

- **HIGH TEMPERATURE (205-260°C / 401-500°F)**

This range is best used to sear and grill at a high heat. Use in tandem with the flame broiler (slide plate) for indirect or direct flame cooking. With the **flame broiler open**, direct flame is used to create those “blue” steaks, as well as flame-kissed vegetables, garlic toast or s’mores! When the **flame broiler is closed**, the air circulates around the barrel, resulting in convection heat. High temperature is also used to preheat your grill, burn-off the cooking grids, and to achieve high heat in extreme cold weather conditions.

- **MEDIUM TEMPERATURE (135-180°C / 275-356°F)**

This range is best for baking, roasting, and finishing off that slow smoked creation. Cooking at these temperatures will greatly reduce the chances of a grease flare-up. Ensure that the flame broiler slider is in the closed position, covering the slotted openings. Great range for cooking anything wrapped in bacon, or where you want versatility with control.

- **LOW TEMPERATURE (80-125°C / 176-257°F)**

This range is used to slow roast, increase smoky flavor, and to keep foods warm. Infuse more smoke flavor and keep your meats juicy by cooking longer at a lower temperature (also known as **low and slow**). Highly recommended for the big turkey at Thanksgiving, juicy ham at Easter, or the huge holiday feast.





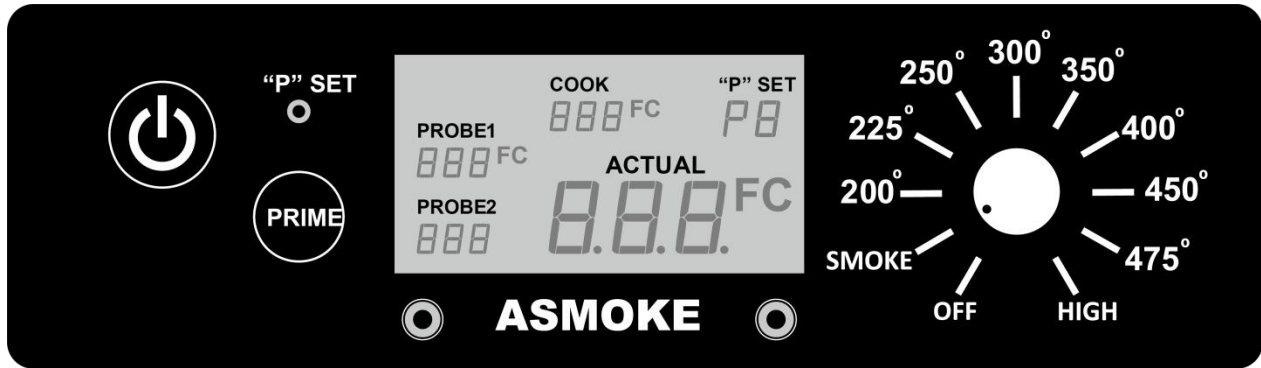

Smoking is a variation on true barbecuing and is truly the main advantage of grilling on a wood pellet grill. **Hot smoking**, another name for **low and slow** cooking, is generally done between 80-125°C / 176-257°F. Hot smoking works best when longer cooking time is required, such as large cuts of meats, fish, or poultry.

TIP: To intensify that savory flavor, switch to SMOKE (low) temperature range immediately after putting your food on the grill. This allows the smoke to penetrate the meats.

The key is to experiment with the length of time you allow for smoking, before the meal is finished cooking. Some outdoor chefs prefer to smoke at the end of a cook, allowing the food to keep warm until ready to serve. Practice makes perfect!

UNDERSTANDING THE CONTROL BOARD



CONTROL	DESCRIPTION
	Press the Power Button to power on the unit, which begins the automatic start-up cycle. Also used to turn the unit off, activating the cool-down cycle.
	The Temperature Control Dial allows you to set your desired smoking temperature. Rotate the knob to select from Smoke, any of the eight temperature presets, or High.
OFF	The Off Setting on the Temperature Control Dial is the off mode for the unit. The unit will not function on this setting.
Smoke	The Smoke Setting on the Temperature Control Dial is the start-up mode for the unit. The grill operates at the lowest temperature, without the fire going out.
High	The High Setting on the Temperature Control Dial is the highest heat level for the unit. The grill operates at the highest temperature. When the lid is open, the grill will run at this speed to compensate for the loss of heat in the barrel.
	LCD Screen is used as the information center for your unit. LCD screen will display your Desired Cook Temperature (Setpoint) , Actual Cook Temperature , Meat Probe Temperature (if connected) , and any error messages. Temperature can be displayed in either Fahrenheit or Celsius.
	Press and hold the Prime Button to activate an extra feed of pellets to the burn grate. This can be used to add more fuel to the fire before opening the barrel lid, resulting in a quick heat recovery time. It can also be used while smoking, to increase the intensity of clean smoke flavor. Requested from competition cookers.
	The plug-in connection port on the front of the Digital Control Center is for a Meat Probe . When the meat probe is connected, the temperature is displayed on the LED Screen. When not in use, disconnect the meat probe from the connection port. <i>Includes one (1) meat probe. Compatible with Louisiana Grills branded meat probes only.</i> 
"P" SET	The "P" SET Button is used to select one of the eight temperature fine tunings. Use this feature to change the "P" setting to accommodate to your cooking style and cooking environment, as preferred. With a short push of the recessed button, the setting increases from P0 to P7, then repeats. Adjustments are best made when the Temperature Control Dial is set to Smoke , which allows for manual control of the pellet feed system. Default setting is "P4".

UNDERSTANDING THE PROBES

• TEMPERATURE PROBE

Located inside the main barrel, on the left side wall, is the temperature probe. It is a small, vertical piece of stainless steel. The temperature probe measures the internal temperature of the unit. When the temperature is adjusted on the Control Board, the temperature probe will read the actual temperature inside the unit and adjust to the desired temperature.

IMPORTANT: The temperature of your unit is highly affected by ambient outdoor weather, quality of pellets used, flavor of pellets, and the quantity of food being cooked.

• MEAT PROBE

The meat probe measures the internal temperature of your meat in the grill, similar to your indoor oven. Plug-in the meat probe adapter to the meat probe connection port on the Control Board and insert the stainless steel meat probe into the thickest portion of your meat and the temperature will be displayed on the control board. **To ensure the meat probe is connected properly to the connection port, feel and hear it snap into place.**

NOTE: When placing the meat probe into your meat, ensure the meat probe and meat probe wires avoid direct contact with flame or excess heat. This can result in damage to your meat probe. Run the excess wire out the hole located on the left side of the main grill or the top of the main grill (near the grill lid hinge). When not in use, disconnect from the meat probe connection port and place aside to keep protected and clean.

UNDERSTANDING THE "P" SETTING

The main benefit to the "P" SET (setting) button is that it allows the cook to have fine tuned control of their grill in SMOKE mode, to compensate for ambient temperature, humidity, wind, environmental changes, pellet fuel type and quality.

When the "P" SET button is pushed, the "P" setting displayed on the LCD screen will change to the next value (upward). Once P7 is reached, it will restart at P0. There are eight "P" settings, ranging from P0 to P7.

USING THE "P" SETTING IN SMOKE MODE

Anytime the temperature dial is set to the SMOKE setting, such as the start-up of the unit, the auger will run on a manual mode of cooking versus using one of the preset temperatures on the Temperature Control Dial.

• MORE SMOKE FLAVOR, LESS HEAT

(↑ "P" SETTING / ↓ FUEL FEED)

When hot smoking – increasing the infusion of more natural wood flavor – increase the "P" setting to allow for longer cycles between auger feeds. This results in keeping a lower temperature output, which increases cook time (also known as **low and slow**), a deeper **smoke ring** and more smoke flavor. Care must be taken when using the higher "P" settings, such as P6 or P7, as this could result in the fire going out in the fire pot.

• LESS SMOKE FLAVOR, MORE HEAT

(↓ "P" SETTING / ↑ FUEL FEED)

A lower "P" setting will result in a higher grill temperature output and higher pellet consumption due to more frequent cycles.

"P" SET	AUGER CYCLE (seconds)	
	ON	OFF
P0	18	55
P1	18	70
P2	18	85
P3	18	100
*P4	18	115
P5	18	130
P6	18	140
P7	18	150

***factory default setting**

HOPPER PRIMING PROCEDURE

These instructions should be followed the first time the grill is ignited, and each time the grill runs out of pellets in the hopper. The auger must be primed to allow pellets to travel through the length of the auger, and fill the fire pot. **If not primed, the igniter will timeout before the pellets are ignited, and no fire will start.** Follow these steps to prime the hopper:

1. Open the hopper lid. Make sure there are no foreign objects in the hopper or blocking the auger feed system at the bottom.
2. Remove all cooking components from the interior of the grill. Locate the fire pot in the bottom of the main barrel.

3. Plug the power cord into a power source. Press the **Power Button** to turn the unit on, and turn the **Temperature Control Dial** to the SMOKE position. Check the following items:
 - That you can hear the auger turning. Place your hand above the fire pot and feel for air movement. Do not place your hand or fingers inside the fire pot. This can cause injury.
 - After approximately a minute, you should smell the igniter burning and begin to feel the air getting warmer in the fire pot. The igniter tip does not glow red, but gets extremely hot and will burn. Do not touch the igniter.
4. Once verified that all electric components are working correctly, press the **Power Button** to turn the unit off.
5. Fill the hopper with all natural barbecue wood pellets.
6. Press the **Power Button** to turn the unit on. Keep the **Temperature Control Dial** in the SMOKE position. Press and hold the **Prime Button** until you see pellets on the inside of the grill from the auger tube. Once pellets begin to drop into the fire pot, release the **Prime Button**.
7. Press the **Power Button** to turn the unit off.
8. Re-install the cooking components into the main barrel. The grill is now ready to use.

FIRST USE – GRILL BURN-OFF

Once your hopper has been primed and before cooking on your grill for the first time, it is important to complete a grill burn-off. Start the grill and operate at any temperature over 176°C / 350°F (with the lid down) for 30 to 40 minutes to burn-off the grill and rid it of any foreign matter.

AUTOMATIC START-UP PROCEDURE

1. Plug the power cord into a grounded power source. Open the main barrel lid. Check the fire pot to ensure there is no obstruction for proper ignition. Open the hopper lid. Ensure there are no foreign objects in the hopper or auger feed system. Fill the hopper with dry, all natural no blend barbecue wood pellets.
2. Ensure the **Temperature Control Dial** is in the SMOKE position. Press the **Power Button** to turn the unit on. This will activate the start-up cycle. The auger feed system will begin to turn, the igniter will begin to glow and the fan will supply air to the fire pot. The grill will begin to produce smoke while the start-up cycle is taking place. The barrel lid must remain open during the start-up cycle. To confirm the start-up cycle has begun properly, listen for a torchy roar, and notice some heat being produced.
3. Once the heavy, white smoke has dissipated, the start-up cycle is complete and you are ready to enjoy your grill at your desired temperature!

IGNITER FAILURE PROCEDURE

If for any reason your electric igniter fails or your grill's flame dies out during a cook, check the following steps, or start your grill using the manual method.

1. Ensure the **Temperature Control Dial** is in the SMOKE position. Open the barrel lid. Remove the cooking components from inside. Remove all unburnt pellets and ash from the fire pot. Avoid touching the igniter to avoid injury, as it may be extremely hot.
2. Once all cooking components are removed and cleaned, press the **Power Button** to turn the unit on. Check the following:
 - Visually confirm that the igniter is working by placing your hand above the fire pot and feeling for heat.
 - Visually confirm that the igniter is protruding approximately 13mm / 0.5 inches in the fire pot.
 - Visually confirm that the auger is dropping pellets into the fire pot.
 - Confirm that the combustion fan is working by listening for a torchy roar.
3. If any of the above points are not working, follow **Troubleshooting** instructions.

MANUAL START-UP PROCEDURE

1. Ensure the **Temperature Control Dial** is in the **SMOKE** position. Plug the power cord into a grounded power source.
2. Check fire pot to ensure there is no obstruction for proper ignition. Open the hopper lid. Ensure there are no foreign objects in the hopper or auger feed system. Fill hopper with dry, all natural hardwood barbecue pellets.
3. Open the barrel lid. Remove the cooking components to expose the fire pot. Place a generous handful of pellets into the fire pot. Squirt a gelled fire starter, or other appropriate pellet starter, over the top of the pellets. A small amount of solid fuel fire starter, such as one composed of sawdust and wax, or wood shavings, is also appropriate. Add another small amount of pellets in the fire pot.

NOTE: Do not use spirit, petrol, gasoline, lighter-fluid or kerosene for lighting or refreshing a fire in your grill.

4. Light the contents of the fire pot using a long match or long-nosed lighter. Allow the starter to burn for 3 to 5 minutes. Do not attempt to add more starter into the fire pot. This can cause injury.
5. Quickly and carefully replace the cooking components to the inside of the main barrel. Continue start-up at step two of **Automatic Start-Up Procedure**.

SHUTTING OFF YOUR GRILL

1. When finished cooking, keep the Main Barrel lid **OPENING**, press and hold the **Power Button** to turn the unit off. This will activate the automatic cool-down cycle. The feed system will stop feeding fuel, the flame will burn out, and the fan will continue to run until the cool-down cycle is completed. Once the cool-down cycle is complete, the fan will turn off then close the Main Barrel lid.

CARE AND MAINTENANCE

Any ASMOKE unit will give you many years of flavorful service with minimum cleaning. Follow these cleaning and maintenance tips to service your grill:

1. HOPPER ASSEMBLY

- The hopper includes a clean-out feature to allow for ease of cleaning and change out of pellet fuel flavors. To empty, locate the plate and the cover of the drop chute on the back side of the hopper. Place a clean, empty pail under the drop chute cover, then remove the cover piece. Unscrew the plate, slide outwards, and pellets will empty.

NOTE: Use a long handled brush or shop-vac to remove excess pellets, sawdust, and debris for a complete clean-out through the hopper screen.

- Running all pellets out of your auger system is recommended if your grill will be unused for an extended period of time. This can be done by simply running your grill, on an empty hopper, until all pellets have emptied from the auger tube.
- Check and clean off any debris from the fan air intake vent, found on the bottom of the hopper. Once the hopper access panel is removed (see **Electric Wire Diagram** for diagram), carefully wipe off any grease build-up directly on the fan blades. This ensures airflow is sufficient to the feed system.

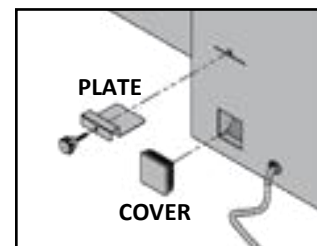

2. PROBES

Kinks or folds in the probe wires may cause damage to the part. Wires should be rolled up in a large, loose coil.

- Although the probes are stainless steel, do not place in the dishwasher or submerge in water. Water damage to the internal wires will cause the probe to short-out, causing false readings. If a probe is damaged, it should be replaced.

3. *INSIDE SURFACES*

- It is recommended to clean your fire pot after every few uses. This will ensure proper ignition and avoid any hard build-up of debris or ash in the firepot.
- Use a long-handled grill cleaning brush (brass or soft metal), remove any food or build-up from the cooking grids. Best practice is to do this while they are still warm from a previous cook. Grease fires are caused by too much fallen debris on the cooking components of the grill. Clean the inside of your grill on a consistent basis. In the event you experience a grease fire, keep the grill lid closed to choke out the fire. If the fire does not go out quickly, carefully remove the food, turn the grill off, and shut the lid until the fire is completely out. Lightly sprinkle baking soda, if available.
- Check your grease bucket often, and clean out as necessary. Keep in mind the type of cooking you do. Simply insert a disposable foil bucket liner into your grill's grease bucket, then toss when full. It's ready to catch your grill's grease and oil run off for easy clean up and maintenance.

IMPORTANT: Due to high heat, do not cover the flame broiler or probes with aluminum foil.

4. *OUTSIDE SURFACES*

- Wipe your grill down after each use. Use warm soapy water to cut the grease. Do not use oven cleaner, abrasive cleansers or abrasive cleaning pads on the outside grill surfaces. **All painted surfaces are not covered under warranty, but rather are part of general maintenance and upkeep.** For paint scratches, wearing, or flaking of the finish, all painted surfaces can be touched up using high heat BBQ paint.
- Use a grill cover to protect your grill for complete protection! A cover is your best protection against weather and outside pollutants. When not in use or for longterm storage, keep the unit under a cover in a garage or shed.

CLEANING FREQUENCY TIME TABLE (NORMAL USE)

ITEM	CLEANING FREQUENCY	CLEANING METHOD
Bottom of Main Grill	Every 5-6 Grill Sessions	Scoop Out, Shop-Vac Excess Debris
Fire pot	Every 2-3 Grill Sessions	Scoop Out, Shop-Vac Excess Debris
Cooking Grids	After Each Grill Session	Burn Off Excess, Brass Wire Brush
Flame Broiler	Every 5-6 Grill Sessions	Scrape Main Plate with Slider, Do Not Wash Clean
Front Shelf	After Each Grill Session	Scrub Pad & Soapy Water
Grease Bucket	After Each Grill Session	Scrub Pad & Soapy Water
Auger Feed System	When Pellet Bag is Empty	Allow Auger to Push Out Sawdust, Leaving Hopper Empty
Hopper Electric Components	Once A Year	Dust Out Interior, Wipe Fan Blades with Soapy Water
Air Intake Vent	Every 5-6 Grill Sessions	Dust, Scrub Pad & Soapy Water
Temperature Probe	Every 2-3 Grill Sessions	Scrub Pad & Soapy Water

USING WOOD PELLET FUEL

Clean-burning barbecue wood pellets generate about 8200 BTU's per pound with very little ash, a low moisture content (5-7%), and are carbon neutral. Barbecue wood pellets are produced by pure raw material (sawdust) being pulverized with a hammer-mill, and the material is pushed through a die with pressure. As the pellet is forced through the die, it is cut, cooled, screened, vacuumed, and then bagged for consumer use. Check with your local dealer for flavors available in your area.

ASMOKE 100% Apple Cooking Pellets: Looking for something less heavy than hickory smoke? No artificial flavoring or other wood blends are in our cooking pellets. Apple wood pellets create a light, fruity smoke that enhances beef, Lamb, chicken, pork, seafood, and vegetables. SO YOU DON'T NEED OTHER SMOKING FLAVORS.

















































HOW TO USE APPLE WOOD PELLETS

You can use ASMOKE Apple barbecue pellets to enhance the flavor of your food. The apple component offers a lighter, sweeter smoke than flavors such as hickory, oak or mesquite. This pairs well with food such as beef, Lamb, chicken, pork, seafood, vegetables, and desserts. Whenever you're grilling and you want a sweeter but still smokey taste, ASMOKE Apple BBQ pellets are the way to go.

Our pellets are not just for grilling, either. You can use our 100 percent apple wood pellets for smoking, barbecuing, baking, roasting, and braising. ASMOKE Apple pellets are a perfect all-around pellet for all you pellet grilling needs.

WHY ASMOKE APPLE BBQ PELLETS

Why choose ASMOKE Apple smoking pellets over another company? It's simple: our quality. The quality of our BBQ pellets is unmatched. We use 100 percent apple wood that's sourced from fresh orchard. We care about giving our customers the best possible wood pellets so they can cook meals with enhanced flavor. ASMOKE doesn't pretend to be something it's not. We don't blend the apple wood with any other wood species and try to pass it off as 100% apple wood. We don't use flavoring oils in a base wood to try and pass it off as apple. No fillers, no blends, no additions.

Hardwood	Beef	Poultry	Pork	Lamb	Seafood	Bake	Wild Game	Vegetables
Mesquite								
Hickory								
Whiskey								
Competition Blend								
Fruitwood	Beef	Poultry	Pork	Lamb	Seafood	Bake	Wild Game	Vegetables
Cherry								
Apple								
Jujube								
Lychee								
Guava								



ASMOKE 100% Apple Wood Pellet 5 LBS/2.27KG



ASMOKE 100% Apple Wood Pellet 20 LBS/9.07KG

COOKING GUIDELINES

Smoking and grilling styles of cooking can give you different results based on time and temperature. For best results, keep a record of what you cooked, at what temperature, how long you cooked for, and the results. Adjust to your taste for the next time. Practice makes perfect.

The culinary art of hot smoking refers to longer cooking times, but results in more natural wood flavor (and a sought-after *smoke ring*) on your meats. Higher cooking temperatures result in a shorter cooking time, locking in less smoke flavor.

TIP: For best results, allow time for meats to rest after cooking. This allows the natural juices to migrate back into the meat fiber, giving a much juicier, flavorful cut. Resting times can be as little as 3 minutes and up to 60 minutes, depending on the size of the protein.

STYLE OF COOKING	HOT SMOKING (Very Low)	ROAST (Low)	BAKING (Medium)	GRILL/BAKE (Medium/High)	SEAR (High)
Temp Range	93-135°C / 199-275°F	135-162°C / 275-323°F	162-190°C / 323-374°F	190-232°C / 374-449°F	232-260°C/449-500°F

POULTRY	Size	Rare - 54°C / 130°F	Medium - 60°C / 140°F	Well Done - 77°C / 170°F
Turkey (<i>whole</i>)	4.5-5.0 kg / 10-11 lbs. 5.3-6.4 kg / 12-14 lbs. 6.8-7.7 kg / 15-17 lbs. 8.2-10.0 kg / 18-22 lbs. 10.4-11.3 kg / 23-25 lbs.			Grill 90 - 120 minutes Grill 110 - 140 minutes Grill 130 - 160 minutes Grill 140 - 170 minutes Grill 150 - 180 minutes
Chicken (<i>whole</i>)	1.36-2.26 kg / 3-5 lbs.			Grill 1 - 1.5 hours
Drumsticks, Breasts	0.45-0.86 kg / 1-1½ lbs.			Grill 30-60 minutes
Small Game Birds	0.45-0.86 kg / 1-1½ lbs.			Grill 30-45 minutes
Duck	1.36-2.26 kg / 3-5 lbs.			Roast or grill 2 - 2.5 hours
PORK	SIZE	Precooked to Reheat 60°C / 140°F	Medium 66°C / 150°F	Well Done 71°C / 160°F
Ham (<i>Fully Cooked & Boneless Portion, Smoked Picnic Whole & Bone-In</i>)	2.5 cm / 1" 1.36-1.81 kg / 3-4 lbs. 1.81-2.72 kg / 4-6 lbs. 2.26-3.62 kg / 5-8 lbs. 4.53-5.44 kg / 10-12 lbs.	12 minutes 50 minutes - 1 hour 1 - 2 hours 1 - 2½ hours 2 - 2¾ hours		
Loin Roast	1.36-1.81 kg / 3-4 lbs.		1 - 2 hours	2 - 3 hours
Rib Crown Roast	1.81-2.26 kg / 4-5 lbs.		1½ - 2 hours	2 - 3 hours
Chop (<i>loin, rib</i>)	1.9-2.5 cm / ¾" - 1" 3.1-3.9 cm / 1¼" - 1½"		10-12 minutes 14-18 minutes	
Tenderloin	1.9-2.5 cm / ¾" - 1"		20 - 30 minutes	30 - 45 minutes
Loin Roast (<i>boneless</i>)	1.36-2.26 kg / 3-5 lbs.		1¼ - 1¾ hours	1¾ - 2½ hours
Boston Butt (<i>Pork Shoulder</i>)	3.62-4.53 kg / 8-10 lbs.			93 - 98°C / 200 - 210°F Internal Temperature

LAMB	Size	Rare - 54°C / 130°F	Medium - 60°C / 140°F	Well Done - 71°C / 160°F
Roast (<i>fresh</i>)	2.26 - 2.72 kg / 5 - 6 lbs.		1 - 2 hours	
Rib Crown Roast	1.36-2.26 kg / 3-5 lbs.		1 - 1½ hours	1½ hours

WILD GAME	Size	Rare - 60°C / 140°F	Medium - 71°C / 160°F	Well Done - 77°C / 170°F
Roast (<i>fresh</i>)	2.26 - 2.72 kg / 5 - 6 lbs.		1 - 1½ hours	1½ - 2 hours
Large Cuts (<i>fresh</i>)	3.62-4.53 kg / 8-10 lbs.		1 hours	1½ hours

BEEF	SIZE	HEAT	Rare - 54°C / 130°F	Medium - 60°C / 140°F	Well Done - 65°C / 150°F
Steak (<i>New York, Porter-house, Rib-eye, Sirloin, T-bone, or Tenderloin</i>)	1.9 cm / ¾" 2.5 cm / 1" 3.8 cm / 1½" 5 cm / 2"	High	Sear 8-10 minutes Sear 10-12 minutes Sear 10 minutes, grill 8-10 minutes Sear 10 minutes, grill 10-14 minutes		
Skirt Steak	0.6 - 12.7 cm / ¼" - ½"	High	Sear 5-7 minutes		
Flank Steak	0.45 - 0.86 kg / 1 - 1½ lbs., 1.9 cm / ¾"	Medium	Sear 4 minutes, grill 8-10 minutes		
Kabob	2.5-3.8cm/1-1½" cubes	Medium	Grill 10 - 12 minutes		
Tenderloin, whole	1.58-1.81kg/3½-4lbs.	High/Medium	Sear 10 minutes, grill 15-20 minutes		
Ground Beef Patty	1.9 cm / ¾"	High/Medium	Sear 4 minutes, grill 4-6 minutes		
Rib-eyeRoast(<i>boneless</i>)	2.26 - 2.72 kg / 5 - 6 lbs.	Medium	Grill 1½ - 2 hours		
Tri-tip Roast	0.9 - 1.13 kg / 2 - 2½ lbs.	High/Medium	Sear 10 minutes, grill 20-30 minutes		
Rib Roast	5.44-6.35kg/12-14lbs.	Medium	2½ - 2¾ hours		
Veal Loin Chop	2.5cm / 1"	Medium	10 - 12 minutes direct		
Brisket	7.25-3.62 kg / 16-18 lbs.	Hot Smoke	Cook until internal temperature reaches 91°C / 195°F		

SEAFOOD	Size	Rare - 54°C / 130°F	Medium - 60°C / 140°F	Well Done - 82°C / 180°F
Fish (<i>whole</i>)	0.5 kg / 1 lb. 0.9 - 1.1 kg / 2 - 2½ lbs. 1.4 kg / 3 lbs.			Grill 10 - 20 minutes Grill 20 - 30 minutes Grill 30 - 45 minutes
Fish (<i>filets</i>)	0.6-1.3 cm / ¼" - ½"			Grill 3 - 5 minutes, until flaky
Lobster Tail	0.15kg/5oz. 0.3kg/10oz.			Grill 5 - 6 minutes Grill 10 - 12 minutes

HOW TO USE MEAT PROBE

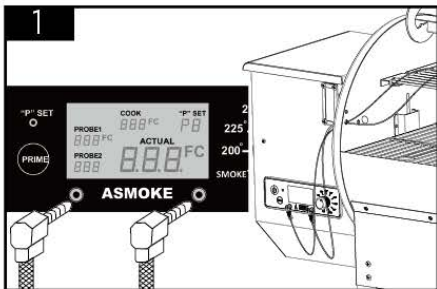

Insert the meat probe's plug into the socket on the lower middle of the controller, then route the probe cable through the hole in the left of grill as shown.

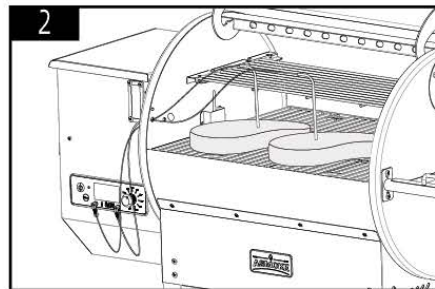

Insert probe tip into meat. Make sure it is not in the fatty portion or touching bone, but is halfway into the thickest part of the meat.

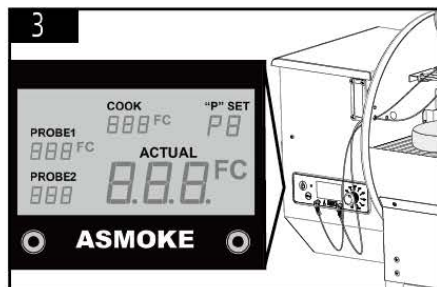

Reading the temperature :Both probe temperature and grill temperature will display on controller.

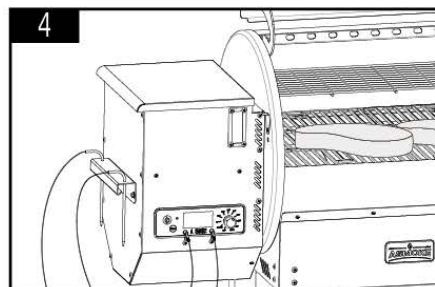

Left side have a small shelf for you holding meat probe after using.

TIPS & TECHNIQUES

Follow these helpful tips and techniques, passed on from ASMOKE owners, our staff, and customers just like you, to become more familiar with your grill:

1. *FOOD SAFETY*

- Keep everything in the kitchen and cooking area clean. Use different platters and utensils for the cooked meat than the ones you used to prepare or transport the raw meat out to the grill. This will prevent cross contamination of bacteria. Each marinade or basting sauce should have its own utensil.
- Keep hot foods hot (above 60°C / 140°F), and keep cold foods cold (below 3°C / 37°F).
- A marinade should never be saved to use at a later time. If you are going to use it to serve with your meat, be sure to bring it to a boil before serving.
- Cooked foods should not be left out in the heat for more than an hour. Do not leave hot foods out of refrigeration for more than two hours.
- Defrost and marinate meats by refrigeration. Do not thaw meat at room temperature or on a counter top. Bacteria can grow and multiply rapidly in warm, moist foods. Wash hands thoroughly with hot, soapy water before starting any meal preparation and after handling fresh meat, fish and poultry.

2. *COOKING PREPARATION*

- Be prepared, or *Mise en Place*. This refers to preparing the cooking recipe, fuel, accessories, utensils, and all ingredients you require at grill side before you start cooking. Also, read the entire recipe, start to finish, before lighting the grill.
- ABBQ floor mat is very useful. Due to food handling accidents and cooking spatter, a BBQ floor mat would protect a deck, patio, or stone platform from the possibility of grease stains or accidental spills.

3. *GRILLING TIPS AND TECHNIQUES*

- To infuse more smoke flavor into your meats, cook longer and at lower temperatures (also known as *low and slow*). Meat will close its fibers after it reaches an internal temperature of 49°C / 120°F. Misting, or mopping, are great ways to keep meat from drying out.
- While searing your meats, cook with the lid down. Always use a meat thermometer to determine the internal temperature of the foods you are cooking. Smoking foods with hardwood pellets will turn meats and poultry pink. The band of pink (after cooking) is referred to as a *smoke ring* and is highly prized by outdoor chefs.
- Sugar-based sauces are best applied near the end of cooking to prevent burning and flare-ups.
- Leave open space between the foods and the extremities of the barrel for proper heat flow. Food on a crowded grill will require more cooking time.
- Use a set of long-handled tongs for turning meats, and a spatula for turning burgers and fish. Using a piercing utensil, such as a fork, will prick the meat and allow the juices to escape.
- Foods in deep casserole dishes will require more time to cook than a shallow baking pan.
- It's a good idea to put cooked food onto a heated platter, keeping the food warm. Red meats, such as steak and roasts, benefit from resting for several minutes before serving. It allows the juices that were driven to the surface by heat to ease back to the center of the meat, adding more flavor.

TROUBLESHOOTING

Proper cleaning, maintenance and the use of clean, dry, quality fuel will prevent common operational problems. When your ASMOKE grill is operating poorly, or on a less frequent basis, the following troubleshooting tips may be helpful.

For FAQ, please visit www.asmokegrill.com. You may also contact your local ASMOKE authorized dealer or contact Customer Service for assistance.

WARNING: Always disconnect the electrical cord prior to opening the grill for any inspection, cleaning, maintenance or service work. Ensure the grill is completely cooled to avoid injury.

PROBLEM	CAUSE	SOLUTION
No Power Lights On The Control Board	Temperature Control Dial is still off.	Press the Power Button, and ensure the button glows blue to show there is a power connection. Turn the Temperature Control Dial to a temperature setting.
	Not Connected To Power Source	Ensure unit is plugged into a working power source. Reset breaker. Ensure GFCI is a minimum 10 Amp service (see <i>Electric Wire Diagram</i> for access to electric components) Ensure all wire connections are firmly connected and dry.
	Fuse Blown On The Control Board	Remove hopper access panel (see <i>Electric Wire Diagram</i> for diagram), press in plastic tabs holding the control board in place and carefully pull controller inside the hopper to release controller. Check the fuse for a broken wire or if the wire has turned black. If yes, fuse needs to be manually replaced.
	The GFCI outlet has been tripped.	Remove hopper access panel (see <i>Electric Wire Diagram</i> for diagram), and ensure all wire connections are firmly connected and dry. Ensure GFCI is a minimum 10 Amp service.
	Faulty Control Board	Control Board needs to be replaced. Contact Customer Service for a replacement part.
Fire in Firepot Will Not Light	Auger Not Primed	Before the unit is used for the first time or anytime the hopper is completely emptied out, the auger must be primed to allow pellets to fill the auger tube. If not primed, the igniter will timeout before the pellets reach the fire pot. Follow <i>Hopper Priming Procedure</i> .
	Auger Motor Is Jammed	Remove cooking components from the main barrel. Press the Power Button to turn the unit on, turn Temperature Control Dial to SMOKE, and inspect the auger feed system. Visually confirm that the auger is dropping pellets into the fire pot. If not operating properly, call Customer Service for assistance or a replacement part.
	Igniter Failure	Remove cooking components from the main barrel. Press the Power Button to turn the unit on, turn Temperature Control Dial to SMOKE, and inspect the igniter. Visually confirm that the igniter is working by placing your hand above the fire pot and feeling for heat. Visually confirm that the igniter is protruding approximately 13mm / 0.5 inches in the fire pot. If not operating properly, follow <i>Manual Start-up Procedure</i> to continue use of grill; however, call Customer Service for assistance or a replacement part.
Flashing Dots On LCD Screen	The Igniter Is On	This is not an error that effects the grill. Used to show that the unit has power and is in Start-Up mode (igniter is on). The igniter will turn off after five minutes. Once the flashing dots disappear, the grill will begin to adjust to the desired temperature selected.
Flashing Temperature On LCD Screen	Grill Temperature Is Below 65°C / 150°F	This is not an error that effects the unit; however, it is used to show that there is some risk that the fire could go out. Check hopper for sufficient fuel or if there is an obstruction in the feed system. Remove pellets and follow <i>Care and Maintenance</i> instructions. Check grill temperature probe and follow <i>Care and Maintenance</i> instructions if dirty. Check fire pot for ash build-up or obstructions, and follow <i>Care and Maintenance</i> instructions for ash build-up. Check fan. Ensure it is working properly and air intake is not blocked. Follow <i>Care and Maintenance</i> instructions if dirty. Check auger motor to confirm operation (rotation), and ensure there is no blockage in the auger tube.

"ErH" Error Code	The Unit Has Overheated, Possibly Due To Grease Fire Or Excess Fuel.	Press the Power Button to turn the unit off, and allow grill to cool. Follow Care and Maintenance instructions. After maintenance, remove pellets, and confirm positioning of all component parts. Once cooled, press the Power Button to turn the unit on, then select desired temperature. If error code still displayed, contact Customer Service.
"Err" Error Code	Temperature probe wire not making connection.	Remove hopper access panel (see Electric Wire Diagram for diagram), and check for any damage to the Temperature Probe wires. Ensure Temperature Probe molex connectors are firmly connected, and connected correctly, to the Control Board.
"ErP" Error Code	Unit Not Turned Off Properly When Last Connected To Power.	Safety feature prevents an automatic restart. Press the Power Button to turn the unit off, wait two minutes, then press the Power Button to turn the unit on again. Turn Temperature Control Dial to SMOKE or desired temperature. If error code still displayed, contact Customer Service.
	Power Outage While Unit In Operation.	
"noP" Error Code	Bad Connection At Connection Port	Disconnect meat probe from connection port on the Control Board, and reconnect. Ensure the meat probe adapter is firmly connected. Check for signs of damage to the adapter end. If still failed, call Customer Service for replacement part.
	Meat Probe Damaged	Check for signs of damage to the wires of the meat probe. If damaged, call Customer Service for replacement part.
	Faulty Control Board	Control Board needs to be replaced. Contact Customer Service for a replacement part.
Grill Temperature on SMOKE is too high	"P" Setting is too LOW	Push the "P" SET button, and increase the "P" setting.
Grill Will Not Achieve Or Maintain Stable Temperature	Insufficient Air Flow Through Fire pot	Check fire pot for ash build-up or obstructions. Follow Care and Maintenance instructions for ash build-up. Check fan. Ensure it is working properly and air intake is not blocked. Follow Care and Maintenance instructions if dirty. Check auger motor to confirm operation, and ensure there is no blockage in the auger tube. Once all the above steps have been done, start the grill, set temperature to SMOKE and wait for 10 minutes. Check that the flame produced is bright and vibrant.
	Lack Of Fuel, Poor Fuel Quality, Obstruction In Feed System	Check hopper to check that fuel level is sufficient, and replenish if low. Should the quality of wood pellets be poor, or the length of the pellets too long, this may cause an obstruction in the feed system. Remove pellets and follow Care and Maintenance instructions.
	Temperature Probe	Check status of temperature probe. Follow Care and Maintenance instructions if dirty. Contact Customer Service for a replacement part if damaged.
Grill Produces Excess Or Discolored Smoke	Grease Build-Up	Follow Care and Maintenance instructions.
	Wood Pellet Quality	Remove moist wood pellets from hopper. Follow Care and Maintenance instructions to clean out. Replace with dry wood pellets.
	Fire pot Is Blocked	Clear fire pot for moist wood pellets. Follow Hopper Priming Procedure .
	Insufficient Air Intake For Fan	Check fan. Ensure it is working properly and air intake is not blocked. Follow Care and Maintenance instructions if dirty.
Frequent Flare-Ups	Cooking Temperature	Attempt cooking at a lower temperature. Grease does have a flash point. Keep the temperature under 176°C / 350°F when cooking highly greasy food.
	Grease Build-Up On Cooking Components	Follow Care and Maintenance instructions.

ELECTRICAL WIRE DIAGRAM

The Digital Control Board system is an intricate and valuable piece of technology. For protection from power surges and electrical shorts, consult the wire diagram below to ensure your power source is sufficient for the operation of the unit.

AS-ELECTRIC REQUIREMENTS

110V~120V, 3.1AMP, 60Hz, 250W, 3-PRONG GROUNDED PLUG

NOTE: Electrical components, passed by product safety testing and certification services, comply with a testing tolerance of $\pm 5-10$ percent.

LOCATE AND REMOVE THE EIGHT SCREWS OF ACCESS PANEL ON UNDERSIDE OF UNIT

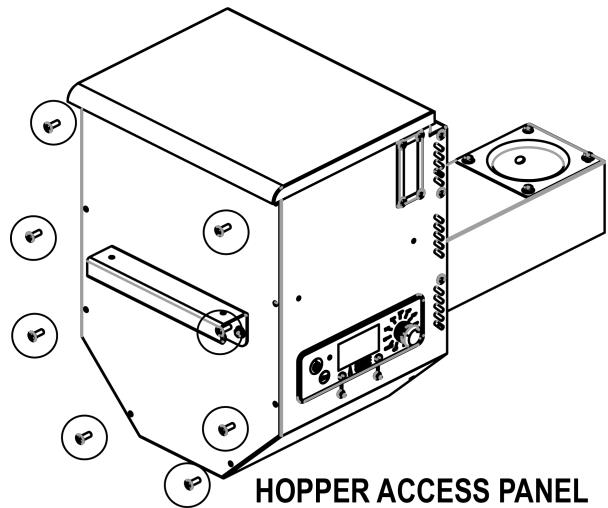

HOPPER ACCESS PANEL (8 screws)

INDEX

W : WHITE	K : BLACK
Y : YELLOW	S : SILVER
P : PURPLE	G : GREEN
R : RED	

FUEL INPUT RATING: 1.12 KG/H (2.48 LB/H)

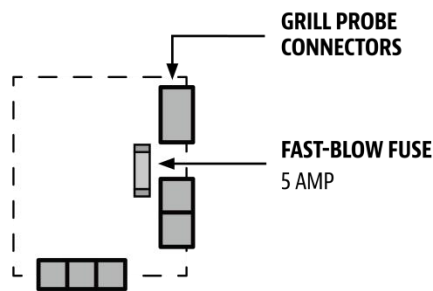

DIGITAL CONTROL BOARD

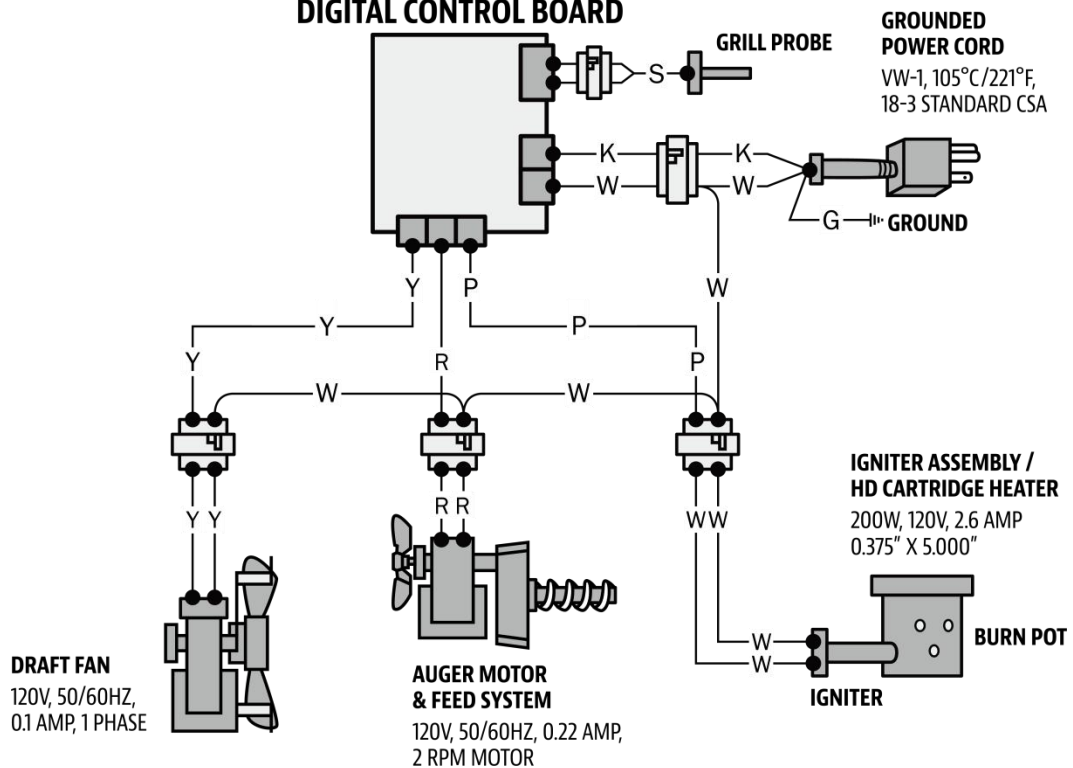

GRILL REPLACEMENT PARTS

Part#	Description
1	Lid Handle
2	Lid Handle Bezel (x2)
3	Main Lid
4	Hopper Assembly
5	Chimney Cap
6	Chimney
7	Chimney Gasket
8	Serving Tray Handle
9	Serving Tray
10	Serving Tray Bracket
11	Pin
12	Grease Bucket
13	Porcelain-Coated Steel Upper Cooking Rack
14	Porcelain-Coated Cast-Iron Cooking Grids (x2)
15	Flame Broiler Slider
16	Flame Broiler Main Plate
17	Short Support Leg (x2)
18	Long Support Leg (x2)
19	Wheel Axle Pin (x2)
20	Wheel (x2)
21	Wheel Cotter Pin (x2)
22	Wheel Axle Washer (x2)
23	Bottom Shelf
24	Locking Caster Wheel (x2)
25	Hopper Handle
26	Main Barrel
27	Hopper Housing Gasket

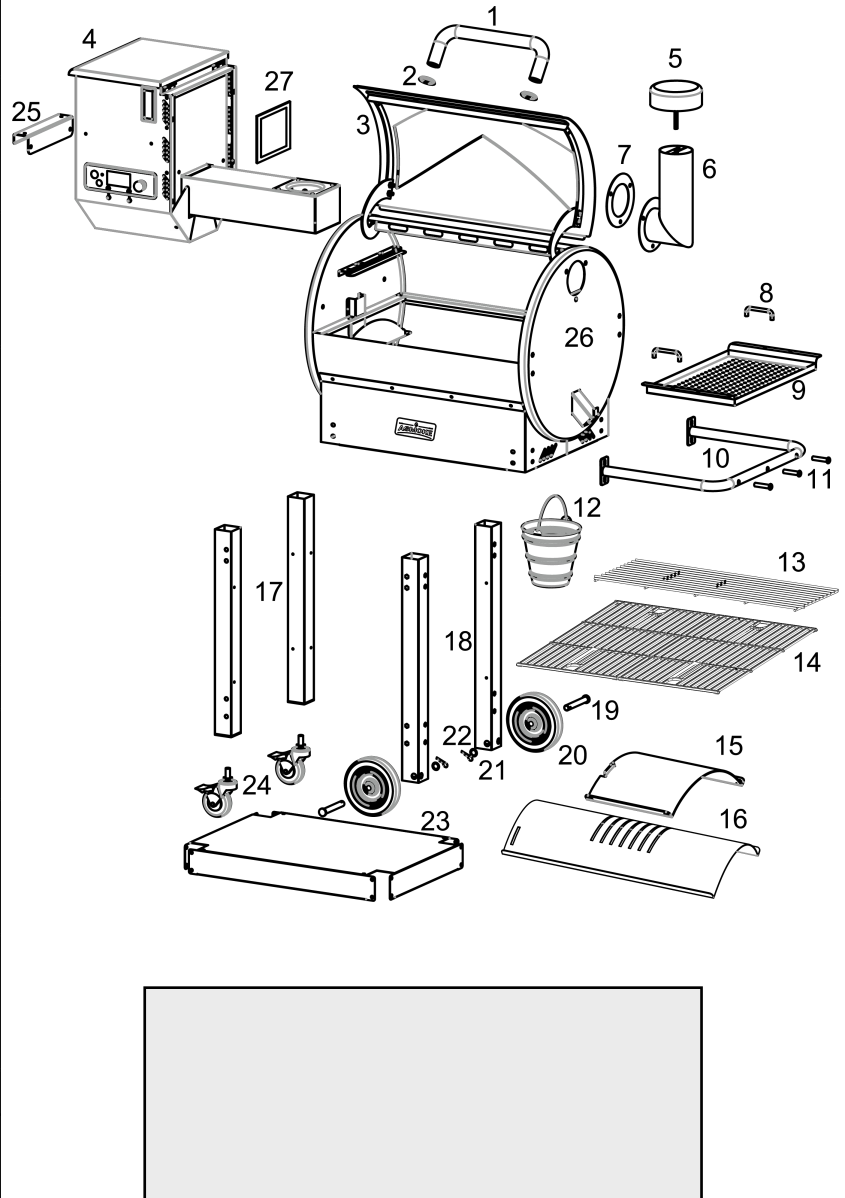

NOTE: Due to ongoing product development, parts are subject to change without notice.

HOPPER REPLACEMENT PARTS

No.	Description
1	Hopper Lid
2	Hopper Safety Screen
3	Hopper Access Panel
4	Hopper Housing
5	Auger Box Housing
6	Fire Pot
7	Auger Motor
8	Combustion Fan
9	Nylon Bushing
10	Auger Flighting Assembly
11	Lgniter
12	ASmoke Control Board
13	Hopper Housing Gasket

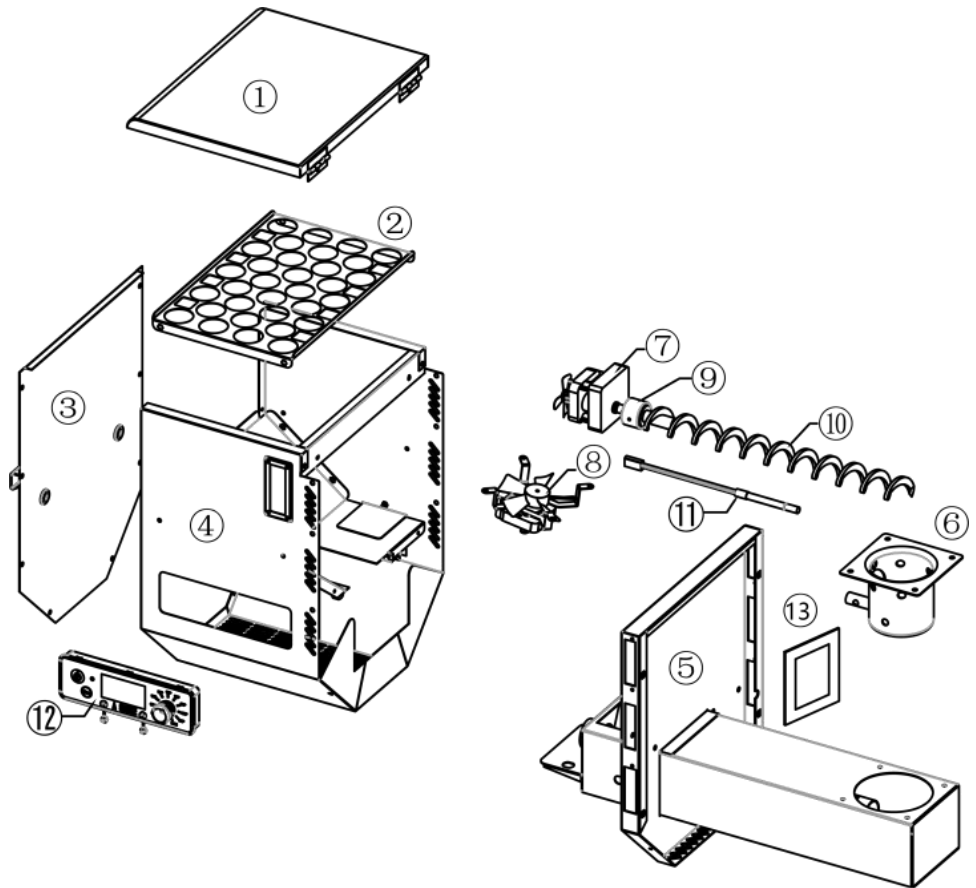

EXCEPTIONS

There is no written or implied performance warranty on ASMOKE grills, as the manufacturer has no control over the installation, operation, cleaning, maintenance or the type of fuel burned. This warranty will not apply nor will ASMOKE assume responsibility if your appliance has not been installed, operated, cleaned and maintained in strict accordance with this owner's manual. Any use of gas not outlined in this manual may void the warranty. The warranty does not cover damage or breakage due to misuse, improper handling or modifications.

Neither ASMOKE, or authorized ASMOKE dealer, accepts responsibility, legal or otherwise, for the incidental or consequential damage to the property or persons resulting from the use of this product. Whether a claim is made against ASMOKE based on the breach of this warranty or any other type of warranty expressed or implied by law, the manufacturer shall in no event be liable for any special, indirect, consequential or other damages of any nature whatsoever in excess of the original purchase of this product. All warranties by manufacturer are set forth herein and no claim shall be made against manufacturer on any warranty or representation.

Some states do not allow the exclusion or limitation of incidental or consequential damages, or limitations of implied warranties, so the limitations or exclusions set forth in this limited warranty may not apply to you. This limited warranty gives you specific legal rights and you may have other rights, which vary from state to state.

ORDERING REPLACEMENT PARTS

To order replacement parts, please contact your local ASMOKE dealer or visit our online store at: www.asmokegrill.com

CONTACT CUSTOMER SERVICE

If you have any questions or problems, contact Customer Service, Monday through Sunday, 9am - 5pm PST (EN).

support@asmokegrill.com | Toll-Free: 1-877-255-2499

WARRANTY SERVICE

Contact your nearest ASMOKE dealer for repair or replacement parts. ASMOKE requires proof of purchase to establish a warranty claim; therefore, retain your original sales receipt or invoice for future reference. The serial and model number of your ASMOKE can be found inside the lid of the hopper. Record numbers below as the label may become worn or illegible.

MODEL

SERIAL NUMBER

DATE OF PURCHASE

AUTHORIZED DEALER

RECIPES

APPLE WOOD SMOKED BACON

Ingredients:

450g / 1 lb Thick-cut Bacon

Suggested Wood Pellet Flavor: Apple

Instructions:

1. Preheat grill, then reduce to 135°C / 275°F.
2. Lay thick-cut bacon directly on the pellet grill grates.
3. Smoke for 45 – 60 minutes, or until you reach the desired crispness.
4. Remove from the grill and enjoy!

GRILLED SPICED CHICKEN SKEWERS WITH CUCUMBER SALAD

Ingredients:

450g / 1 lb Chicken Tenders

30 ml / 2 tbsp Canola Oil

30 ml / 2 tbsp Curry Powder

15 ml / 1 tbsp Olive Oil

15 ml / 1 tbsp Fresh Lime Juice

1.25 ml / ¼ tsp Cayenne Pepper

56 ml / ¼ c. Chopped Fresh Mint

2 pieces Pita Bread

1 sliced English Cucumber

2 sliced Scallions

1 Chopped Garlic Clove

Dash Kosher Salt

Dash Black Pepper

Plain Greek yogurt and lime wedges, for serving

Suggested Wood Pellet Flavor: Apple / Cherry

Instructions:

1. Preheat grill, then reduce to 177°C / 350°F.
2. Cut chicken tenders into thirds.
3. Toss chicken with canola oil, curry powder, smoked paprika, cayenne pepper, and kosher salt and black pepper.
4. Thread onto skewers. Grill, turning occasionally, until charred and cooked through, 8 to 10 minutes.

5. Grill 2 pieces pita bread until warm and toasted, 1 to 2 minutes.
6. Meanwhile, toss together cucumber, scallions, mint, olive oil, fresh lime juice, and garlic. Season with kosher salt and black pepper. Serve with plain Greek yogurt and lime wedge alongside.

APPLE WOOD SMOKED CHICKEN WINGS

Ingredients:

1,350 g / 3 lbs Fresh Chicken Wings (22-24 Wings)

30 ml / 2 tbsp High-temp Cooking Oil

7.5 ml / ½ tbsp BBQ Rub

56 ml / ¼ c. Yellow Mustard

30 ml / 2 tbsp Honey

7.5 ml / ½ tbsp Chili Powder

1.25 ml / ¼ tsp Granulated Garlic

2.5 ml / ½ tsp Cayenne

56 ml / ¼ c. Apple Cider Vinegar

56 ml / ¼ c. Brown Sugar

Dash Salt & Black Pepper

Suggested Wood Pellet Flavor: Apple

Instructions:

1. Preheat grill, then reduce to 135- 148°C / 275- 300°F. Place a water pan in the smoker and preheat the wood splits.
2. Divide the wings into wings and drumettes, discarding the wingtips. Lightly coat all pieces with cooking oil. Season on all sides with BBQ rub. Rest the wings uncovered in the refrigerator for 1 hour to dry the surface and create a crispy crust.
3. Mix mustard, vinegar, brown sugar, honey, chili powder, salt, pepper, cayenne, and garlic together in a small saucepan over medium-low heat. Whisk until combined, 3 to 5 minutes. Remove from heat.
4. Place the wings on the grill for 45 minutes.
5. Flip the wings and smoke until they reach an internal temperature of 175°F, about 45 more minutes.
6. Lightly dab about ¼ cup of golden mustard sauce onto wings. Return wings to the smoker to set the sauce onto the wings, about 10-15 minutes.
7. Remove from smoker and serve with extra sauce on the side.

BBQ PORK CHOPS WITH BOURBON GLAZE

Ingredients:

283 g / 1/2 lb Bone-in Pork Loin Chops, Trimmed of Excess Fat
2 Garlic Clove, Minced
60 ml / 4 tbsp Sweet BBQ Rub Seasoning
30 ml / 2 tbsp Honey
30 ml / 2 tbsp Worcestershire Sauce
250 ml / 1 c. Ketchup
125 ml / 1/2 c. Brown Sugar
56 ml / 1/4 c. Molasses

Suggested Wood Pellet Flavor: Cherry / Apple

Instructions:

1. Place pork chops onto a sheet pan lined with butcher paper. Season generously with sweet BBQ rub seasoning, making sure to coat all sides of the chops. Set aside while you make the glaze.
2. In a medium-sized mixing bowl, combine the ketchup, brown sugar, molasses, honey, garlic, Worcestershire, and 1 tbsp sweet BBQ rub seasoning. Mix well, add 1 shot of bourbon, mix again until sauce becomes smooth. Transfer sauce into an oven-proof sauce pan.
3. **Preheat grill, then reduce slightly to 190°C/375°F.**
4. Grill the pork chops for 10-15 minutes per side. Place the saucepan on the grill and allow the sauce to come to a boil. Glaze the chops on both sides and let the glaze caramelize onto the chops.
5. Grill the pork chops until they are lightly charred and reach an internal temperature of 145°F - 165°F. Remove the pork chops from the grill and allow them to rest for 5 minutes.
6. Once the pork chops have finished resting, glaze them again if you choose to. Serve immediately.

GRILLED CORN ON THE COB

Ingredients:

Heavy-duty Aluminum Foil
4 ears of Corn, shucked
60 ml / 4 tbsp Butter, softened
Dash Salt
Dash Black Pepper
Dash Paprika

Suggested Wood Pellet Flavor: Apple / Cherry

1. **Preheat grill, then reduce to 177°C / 350°F.**

2. In a small bowl, mix the softened butter, salt, black pepper, and paprika.

3. Tear off a 1-foot section of aluminum foil for each of the corn cobs. Use a knife or spoon to spread butter mix on each cob and then roll up tightly in the aluminum foil

4. Place of pellet grill for 25-30 minutes, turning every 5-10 minutes. Enjoy!

Tip: Can cook at lower temps as well, just add extra time. Meanwhile, toss together cucumber, scallions, mint, olive oil, fresh lime juice, and garlic. Season with kosher salt and black pepper. Serve with plain Greek yogurt and lime wedge alongside.

BBQ PORK SHOULDER

Ingredients:

4,536 g / 10 lb Bone-in Pork Butt
56 ml / 1/4 c. Pork Rub
125 ml / 1/2 c. Apple Juice
60 ml / 4 tbsp Brown Sugar
Dash Salt

Suggested Wood Pellet Flavor: Apple / Cherry

Instructions:

1. Trim pork butt of all excess fat leaving 1/4" of the fat cap attached. Combine 2 Tbsp pork rub, apple juice, brown sugar, and salt in a small bowl stirring until most of the sugar and salt are dissolved.
2. Inject the pork butt every square inch or so with the apple juice mixture. Season the exterior of the pork butt with remaining rub.
3. When ready to cook, start the grill with the lid open until the fire is established (4 to 5 minutes). Set the temperature to 250 degrees F and preheat, lid closed, for 10 to 15 minutes.
4. Place pork butt directly on the grill grate and cook for about 6 hours or until the internal temperature reaches 160 degrees F.
5. Wrap the pork butt in two layers of foil and pour in 1/2 cup of apple juice. Secure tin foil tightly to contain the apple juice.
6. Increase temperature to 275 degrees F and return to grill in a pan large enough to hold the pork butt in case of leaks. Cook an additional 3 hours or until internal temperature reaches 195 degrees F.
7. Remove from the grill and allow to rest 10-15 minutes. Slice the pork butt around the bone and top with BBQ sauce. Serve with your favorite sides. Enjoy!



5-YEAR WARRANTY

Conditions

ASMOKE USA LLC warrants this barbecue grill against defects in material and workmanship under normal use and maintenance for a period of five (5) years from the date of original purchase.

ASMOKE USA LLC will provide a replacement part for any part found to be defective. Original part(s) approved for return by ASMOKE's Parts Department must be returned prepaid.

This warranty does not include labor charges connected with the determination or replacement of defective parts, or freight charges to ship these parts.

ASMOKE USA LLC shall not be liable under this or any implied warranty for incidental or consequential damages. This warranty gives the retail customer specific legal rights and the customer may have other rights which vary from state to state.

This warranty shall be void if the unit is not assembled or operated in accordance with the operation instructions provided with this unit; the unit is resold or traded to another owner; components, accessories, or fuels not compatible with the unit have been used; the unit has been used in a commercial or food service application; or the user has abused or otherwise failed to maintain the unit.

To process a warranty claim, ASMOKE USA LLC may require proof of your date of purchase. You should retain your sales slip or invoice along with this certificate with your valuable documents.



WARNING: Please read the entire manual before installation and use of this electric, pellet fuel burning appliance. Failure to follow these instructions could result in property damage, bodily injury or even death. Contact local building or fire officials about restrictions and installation inspection requirements in your area.

⚠ WARNING: This product can expose you to chemicals including wood dust, which is known to the state of California to cause cancer. Combustion of this product can expose you to chemicals including carbon monoxide, which is known to the state of California to cause birth defects or other reproductive harm. For more information go to WWW.ASMOKEGRILL.COM

VISIT US AT WWW.ASMOKEGRILL.COM

